

11938 SENATE RESOURCES

BP SPILL

4/26/06

Fairbanks Daily News-Miner

Feds scold BP on pipeline maintenance
By SAM BISHOP News-Miner Washington Bureau

Friday, April 28, 2006 - WASHINGTON--A top federal official said Thursday that her agency had received "no acceptable answer" from BP Exploration (Alaska) Inc. about why it hadn't regularly cleaned North Slope oil transit lines, including one that leaked this winter.

The lapse has allowed the lines to accumulate so much sludge that it's delaying more leak-prevention tests, said Stacey Gerard, acting administrator of the Pipeline and Hazardous Materials Safety Administration. She told a House of Representatives subcommittee that most companies clean such pipes every week or two with a "scraper pig."

BP officials, in a statement and a document provided to the News-Miner, disputed that assertion.

BP last cleaned the transit line serving Prudhoe Bay's western operating area in 1998. Sludge that built up in the line may have contributed to the corrosion that apparently caused the leak discovered March 2, Gerard said.

Now the sludge is hindering BP's compliance with the agency's March 15 order to test the lines with a "smart pig" within three months. A smart pig runs inside the lines and records any anomalies.

"At the time that we wrote the order, we did not realize that there was a large amount of deposit that had been built up inside the walls of these pipelines, which needs to be removed prior to the testing with a smart pig," Gerard said.

BP has requested an extension of four to six weeks to deal with the problem, she said.

BP Alaska spokesman Daren Beaudou said the company plans to increase its use of maintenance pigs in the future.

"We're going to improve on what we thought was already a very effective system--one that is supported by the fact that in the 30-year history of operations, prior to the GC-2 transit line spill, no one can remember a leak occurring on a Prudhoe Bay crude oil transit line," he said.

Beaudou said it wasn't clear what the maintenance should occur every week or two, though, as Gerard suggested.

"The frequency of pigging depends on many factors," he said.

The smart pigs that the PHMSA wants used on the transit lines haven't been widely employed on the North Slope because the above-ground pipes are accessible for a wide variety of more precise tests, Beaudou said. BP has conducted more than 3,000 such tests on the three major transit lines since the recent leaks and found that "those lines are fit for service," he said.

Gerard made her comments in response to questions from Rep. Ed Markey, D-Mass., at a hearing before a subcommittee of the House Energy and Commerce Committee. Markey repeatedly asked Gerard why BP had not run a scraping pig through the lines regularly.

"Obviously it can't be that BP doesn't have enough money. Or is it just another cost-saving measure, regardless of what the consequences are?" Markey asked.

He also asked whether the government bore some responsibility for having not regulated this sort of line.

"It was our expectation that they would have been running those scraper pigs, and most companies do run scraper pigs on about a weekly to biweekly basis," Gerard said. "There's a general standard of care that most operators exercise, that are exercised without our regulating them. Obviously we wish we had regulations in place sooner."

Markey's questions were similar to those posed in a six-page letter that Rep. John Dingell, D-Mich., sent Tuesday to Transportation Secretary Norman Mineta. Gerard's pipeline agency is a branch of the U.S. Department of Transportation.

Markey and Dingell both asked why Alyeska Pipeline Service Co. pigs the trans-Alaska oil pipeline every 14 days, while some key feeder lines owned by the North Slope producers have gone 14 years without.

A BP official, in a document prepared in response to Dingell's letter and forwarded to the News-Miner by Beaudou, said pigging is done on an as-needed basis. He contradicted Gerard's assertion that pigging once every week or two is the industry standard.

"The frequency of pigging depends upon many factors including the buildup of sediments and other deposits such as wax," BP's Greg Swank wrote in the response, which he sent to the Association of Oil Pipelines' director in Washington, D.C., on Wednesday.

Paraffin buildup in the Northstar pipeline, for example, requires pigging every two weeks, Swank noted. BP runs about 370 maintenance pigs annually on the North Slope.

Dingell also wrote DOT's Mineta that one BP official had told his committee's staff that "previous attempts were made to operate scraper pigs on the major lines (in the eastern area and on the Lisburne line) ... yet some of these efforts were abandoned due to the volume of sludge being produced."

Swank noted that BP took over those particular lines in 2000 after a merger with Arco and a reconfiguration of Prudhoe Bay operations. Records do not report high sludge volume from pigging the lines in the early 1990s, Swank said, but "anecdotal information suggests that previous attempts to pig the (Prudhoe Bay Eastern Operating Area) line pushed considerable solids to Pump Station 1."

Dingell's letter said the Democratic committee staff member who visited Alaska earlier this month heard such warnings.

"Company officials interviewed by staff said there is potential for approximately 1,000 to 2,500 cubic yards of sludge to be removed from the pipelines" serving the eastern operating area and the Lisburne field, Dingell wrote.

Swank said BP doesn't have a precise estimate of the solids volume. The company plans to run a maintenance pig through all three major transit lines and has requested Alyeska's help to keep sludge from entering the trans-Alaska pipeline.

Beaudou said no one wants the solids to enter "the sales stream."

"You want to have pure hydrocarbon going into that pipeline," he said.

Developing a plan to deal with potential solids has slowed down compliance with the PHMSA's order, Beaudou said.

Gerard said after the hearing Thursday that the solids hadn't been conclusively blamed for the leak on the western transit line.

Swank said sediments in the line "may" contribute to corrosion by absorbing or blocking chemical corrosion inhibitors.

However, officials are also looking at whether the corrosion inhibitors' effectiveness on the western transit line "was

reduced because of a reaction with an emulsion breaker," according to an April 3 letter from BP Alaska's President Steve Marshall to Dingell.

Beaudo explained that the emulsion breaker is added in Gathering Center 2, upstream of the leak location, to help separate water and sediment from the heavy oil that is produced in that area of the field.

"We think that it's unique to that line," Beaudo said.

BP officials have noted that monitoring didn't indicate a problem on the line as recently as September. After the leak was discovered, ultrasonic tests showed "recent and rapid corrosion rates," Swank said.

Washington, D.C., reporter Sam Bishop can be reached at (202) 662-8721 or sbishop@newsminer.com.

**Alaska Department of Revenue
FY 2006 Revenue Sensitivity Matrix for Lost ANS Production**

<u>Historical ANS Price (\$ per Barrel)</u>	
FY 2006 (year-to-date):	59.09
February 2006 (monthly average):	59.26
March 2006 (average):	60.61
April 1-9, 2006 (average):	65.15

<u>Historical ANS Production (mm b/d)</u>	
FY 2006 (year-to-date):	0.857
February 2006 (monthly average):	0.824
March 2006 (average):	0.768
April 1-9, 2006 (average):	0.787

LOSS PER DAY
General Fund Unrestricted Revenue
\$ Million

	Thousand Barrels/Day			
	50	100	150	200
50	0.2	0.5	0.8	1.1
55	0.4	0.8	1.2	1.5
60	0.5	1.0	1.4	1.9
65	0.6	1.2	1.8	2.3

LOSS PER WEEK
General Fund Unrestricted Revenue
\$ Million

	Thousand Barrels/Day			
	50	100	150	200
50	1.7	3.6	5.6	7.5
55	2.7	5.4	8.1	10.7
60	3.5	6.7	10.0	13.2
65	4.2	8.2	12.3	16.3

Note: In FY 2006, at \$60 per barrel ANS crude oil price, if ANS production was reduced by 100,000 barrels/day for one day, it would result in a loss to the General Fund of about \$960,000, if production was reduced by 50,000 barrels/day for one day, the loss to the General Fund is about \$490,000.

Senate Resources

April 26, 2006

BP North Slope Spill Report

NOTES:

- There is one cover sheet - 1 page
- There are 5 signature pages (page 2).
- There is one Table of Contents page
- Executive Summary goes to page 34.
- APPENDIX A, B, & C (4 pages + one blank)
- GPB Leak Detection ... (4 pages + one blank)
- GPB Leak Detection System Overview (24 pages + one blank)
- Appendix 3 ... begins with page number 133 runs to 168 + one blank
- 2000 Work Plan ... begins on page 121 runs to 124

TOTAL: 115 pages

NOTE: The report was received from BP as presented.

**GC-2 TRANSIT LINE SPILL
Prudhoe Bay Western Operating Area
March 2, 2006**

**INCIDENT INVESTIGATION
REPORT**

April 14, 2006

SIGNATURE PAGE



Bryant Chapman, Midcontinent PUL,
North America Gas
& Investigation Team Leader

John Alkire, Corrosion and Materials Advisor, EPTG, Houston

Bill J. Harris, North Slope Safety Engineer

Barry Vest, USW/HSE Committee Representative and GC2 Operator

Randal G. Buckendorf, BPXA Sr. Attorney

Shella Barnes, GPB PUL Assistant

Gary Evans, Environmental Specialist, Alaska Department of Environmental
Conservation

ADEC's Role in this Investigation

Gary Evans, an environmental specialist in ADEC's Industry Preparedness Program, was a participant in BP's initial investigation into the causes of the GC-2 Transit Line spill. ADEC will be conducting an independent review and assessment of the findings of this report. Mr. Evans' participation in the BP investigation has been helpful to ADEC's understanding of the issues and ADEC appreciates BP's willingness to include him on the investigation team.

SIGNATURE PAGE

**Bryant Chapman, Midcontinent PUL,
North America Gas
& Investigation Team Leader**

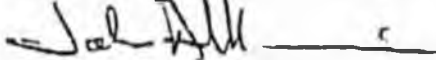

John Alkire, Corrosion and Materials Advisor, EPTG, Houston

Bill J. Harris, North Slope Safety Engineer

Barry Vest, USW/HSE Committee Representative and GC2 Operator

Randal G. Buckendorf, BPXA Sr. Attorney

Sheila Barnes, GPB PUL Assistant

Gary Evans, Environmental Specialist, Alaska Department of Environmental Conservation

ADEC's Role in this Investigation

Gary Evans, an environmental specialist in ADEC's Industry Preparedness Program, was a participant in BP's initial investigation into the causes of the GC-2 Transit Line spill. ADEC will be conducting an independent review and assessment of the findings of this report. Mr. Evans participation in the BP investigation has been helpful to ADEC's understanding of the issues and ADEC appreciates BP's willingness to include him on the investigation team.

SIGNATURE PAGE

Bryant Chapman, Midcontinent PUL,
North America Gas
& Investigation Team Leader

John Alkre, Corrosion and Materials Advisor, EPTG, Houston



Bill J. Harris, North Slope Safety Engineer

Barry Vest, USW/HSE Committee Representative and GC2 Operator



Randal G. Buckendorf, BPXA Sr. Attorney

Shella Barnes, GPB PUL Assistant



Gary Evans, Environmental Specialist, Alaska Department of Environmental
Conservation

ADEC's Role in this Investigation

Gary Evans, an environmental specialist in ADEC's Industry Preparedness Program, was a participant in BP's initial investigation into the causes of the GC-2 Transit Line spill. ADEC will be conducting an independent review and assessment of the findings of this report. Mr. Evans participation in the BP investigation has been helpful to ADEC's understanding of the issues and ADEC appreciates BP's willingness to include him on the investigation team.

SIGNATURE PAGE

Bryant Chapman, Midcontinent PUL,
North America Gas
& Investigation Team Leader

John Alkire, Corrosion and Materials Advisor, EPTG, Houston

Bill J. Harris, North Slope Safety Engineer



Barry Vest, USW/HSE Committee Representative and GC2 Operator

Randal G. Buckendorf, BPXA Sr. Attorney

Shelia Barnes, GPB PUL Assistant

Gary Evans, Environmental Specialist, Alaska Department of Environmental Conservation

ADEC's Role in this Investigation

Gary Evans, an environmental specialist in ADEC's Industry Preparedness Program, was a participant in BP's initial investigation into the causes of the GC-2 Transit Line spill. ADEC will be conducting an independent review and assessment of the findings of this report. Mr. Evans participation in the BP investigation has been helpful to ADEC's understanding of the issues and ADEC appreciates BP's willingness to include him on the investigation team.

SIGNATURE PAGE

Bryant Chapman, Midcontinent PUL,
North America Gas
& Investigation Team Leader

John Alkire, Corrosion and Materials Advisor, EPTG, Houston

Bill J. Harris, North Slope Safety Engineer

Barry Vest, USW/HSE Committee Representative and GC2 Operator

Randal G. Buckendorf, BPXA Sr. Attorney



Shelia Barnes, GPB PUL Assistant

Gary Evans, Environmental Specialist, Alaska Department of Environmental Conservation

ADEC's Role in this Investigation

Gary Evans, an environmental specialist in ADEC's Industry Preparedness Program, was a participant in BP's initial investigation into the causes of the GC-2 Transit Line spill. ADEC will be conducting an independent review and assessment of the findings of this report. Mr. Evans participation in the BP investigation has been helpful to ADEC's understanding of the issues and ADEC appreciates BP's willingness to include him on the investigation team.

TABLE OF CONTENTS

	<u>Page</u>
A. Executive Summary	4
B. Chronology.....	7
C. History of the GC-2 Oil Transit Line	9
D. Production Operations	12
E. Leak Detection System	15
F. Corrosion Inspection Program	22
Appendices	
Appendix A – Detailed Sequence of Events	
Appendix B – List of People Interviewed	
Appendix C – Supporting Information	
Appendix D – Terms of Reference	

A. EXECUTIVE SUMMARY

In the early morning of March 2, 2006, a BP Exploration (Alaska) Inc. (BPXA) Gathering Center 2 (GC-2) well pad operator detected a hydrocarbon smell while driving the pipeline road between GC-2 and GC-1 on the Western side of the Prudhoe Bay Field. Being cognizant of his personal safety, the operator decided not to investigate alone, and continued on to the Base Operations Camp (BOC), whereupon he verbally notified a Security guard and the GC-2 Area Manager. Upon notification, the GC-2 Area Manager and another GC-2 well pad operator departed to drive the same area and after about two miles, they too detected the smell. The GC-2 Area Manager exited the vehicle, carefully climbed up on the piperack and observed oil on the frozen and snow-covered tundra.

The GC-2 Area Manager immediately made a "Code Black" (emergency spill response) notification to the BPXA Communications Center. He and others then worked to confirm the identity of the leak, as there are three pipelines adjacent to the road. Over the next hour, the GC-2 Area Manager initiated the process of shutting down Y and P Pads, the produced water line between GC-2 and GC-1, and all of the GC-2 process facilities and wells pads.

The Mobile Command Center (MCC) was dispatched to the scene. The Incident Command System was activated and a Unified Command structure put in place to develop a spill response, clean-up and disposal plan.

There are 3 separate teams responding to this incident:

- Incident Response Team
- Business Resumption Team
- Incident Investigation Team

The Incident Investigation team, as per the Terms of Reference (Appendix D), was assigned the following objectives:

- Determine the facts and circumstances surrounding the incident
- Establish the sequence of events
- Review applications of management systems, practices, and their impacts
- Compile the report to include incident and response description

Based on an educated assumption that the line failure was a result of corrosion, the investigation team has inquired into the following subject areas:

- Chronology of events leading to the line failure
- History of the GC-2 to GC-1 34 inch pipeline
- Production and operations history that is pertinent to the failure
- Performance of the leak detection system
- History and performance of the corrosion and inspection program

The major factual findings, which are further substantiated and elaborated on in this report, are as follows:

1. Response to the Leak

- The notification and identification of the leak was immediately acted upon in a timely manner
- The shutdown occurred in a logical, expeditious and safe manner
- On March 10, 2006 the Unified Command agreed upon a preliminary spill estimate of 201,169 gallons (4800 barrels) plus/minus 33 percent for a range of 134,783 gallons to 267,555 gallons

2. History of Line

- The GC-2 to GC-1 line has a design pressure of 740 psi
- The current maximum allowable operating pressure (MAOP) is 500 psi. Although the line itself was not explicitly derated from its 740 psi rating, the skid 50 bypass connected to it was derated in 1997, and as a result lowered the entire GC-2 to GC-1 segment to 500 psi. Current operating pressure is 63-91 psi
- Smart pig runs were conducted in 1990 and 1998
- The line has been covered by a comprehensive risk-based corrosion monitoring and management program since the early 1990's
- Production rates from GC-2 through the pipeline were ¼ of peak rate
- There have been no previous leaks or repairs made to this line

3. Production Operations

- There were no operational upsets, i.e., high pressures or rates, that seemed to initiate the leak
- The introduction of viscous oil over the past few years has resulted in higher BS&W content in the GC-2 to GC-1 oil export line and more plant upsets
- GC-2 was experiencing high Basic Sediment and Water (BS&W) the week prior to the leak

4. Leak Detection System

- The leak detection system alarms went off several times during the week preceding March 2, but were ruled out as a spill because of the high BS&W in GC-2 and negative alarm readings on the adjoining segment of line. The leak detection did not sound on March 1st or March 2nd
- Based on the hole size in the pipe, the maximum flow rate is calculated to have been 1000 to 1300 barrels of oil per day (bopd)
- Based on an estimated mean spill volume of 4800 barrels of oil, the leak would have been going on for at least five days and probably much longer
- The leak detection system was working at the time during the incident. We can not identify the event even after the fact.
- Due to process upsets and the non-steady state nature of the process, leak rates of less than 1% may not be detected by this system. It is designed to identify a 1% leak over 24 hours

- The Prudhoe Bay leak detection system, including the GC-2 to GC-1 line segment, was tested and witnessed by ADEC in December 2002 and passed the 1% over 24 hours criteria
- Procedures exist for dealing with positive spill alarms. The established procedure was followed
- The GC-2 to GC-1 oil export line segment has a documented history as being the least accurate in the Prudhoe Bay system due to more BS&W fluctuations

5. Corrosion and Inspection

- Buried caribou and road crossings are not capable, without excavation and sleeve removal, of being inspected via Ultrasonic Thickness (UT) technology
- UT surveillance points on aboveground sections of the line were used to confirm and calibrate the 1998 smart pig run
- The leak location showed only 9% wall loss in the 1998 smart pig run
- Based on numerous surveillance points and corrosion coupons, this line was seen as low corrosion likelihood
- Guided wave UT inspections done both prior to and post leak at the leak location do not show evidence of internal corrosion, nor would it be expected to.
- With the exception of smart pig runs, there isn't a way to directly monitor internal corrosion inside of cased pipe (road and caribou crossings) without having to excavate the crossing and remove the outer casing from the pipe
- Since the leak, UT inspections are suggesting a significantly higher corrosion rate over the past six months since the last set of UT inspections on the aboveground sections of the line in September 2005
- There was some evidence of a slight increase in corrosion rates beginning in 2004 and, although they were not alarmingly high, increased inspections were scheduled for 2005
- The increased inspections that were scheduled in 2004 were inspected in the fall of 2005 and the UT inspections again showed a slight increase. As a result of these inspections the line was placed on a biennial monitoring program and a smart pig run was scheduled for 2006 and funding was secured
- A change in the fall of 2005 in emulsion breaking chemicals inside GC-2 coincide with the time of the recent increased corrosion rate
- Evidence exists of bacterial growth in GC-2
- Evidence exists that carry over corrosion inhibitor is less in GC-2 than in similar facilities
- Facts suggest that the increase in corrosivity in this line may be due to increased bacteria activity from growth in GC-2 and lack of sufficient inhibitor carryover

B. CHRONOLOGY

(See Appendix A for the detailed Sequence of Events)

On Thursday, March 2, 2006 at 5:30 a.m., a GC-2 well pad operator notified the GC-2 lead operator, a Security guard, and the GC-2 Area Manager that he had just driven the GC-2 to GC-1 line segment and had noticed the smell of hydrocarbons. Being cognizant of his personal safety, the operator had decided not to investigate alone, and had continued on to the BOC to make the notifications.

Following this notification, the GC-2 Area Manager and another GC-2 well pad operator immediately departed the BOC to drive the pipeline road to investigate. After traveling two miles driving slowly, they too detected the hydrocarbon smell. They swept the area slowly with a truck spotlight, looking for indications of a leak or heat plume. While passing near the first caribou crossing from the GC-2 end of the pipeline road, heading east, the well pad operator thought he noticed a small heat plume. The GC-2 Area Manager exited the vehicle and approached the pipelines but still could not detect the leak. He informed the well pad operator that he was going to walk out on the snow covering the pipelines and proceeded to carefully do so, taking care to distribute his weight evenly to protect from snow caves. After ascending onto the pipeline, he saw an open snow cave with liquids running off what appeared to be the third pipeline in from the road. He removed himself to a safe location and called GC-2 and the Central Control Room and activated a "Code Black" (emergency spill response). The BP Communication Center logged the Code Black at 5:58 a.m.

BPXA began to immediately notify relevant agencies, including the Alaska Department of Environmental Conservation ("ADEC") through a call to the Alaska State Troopers at 6:15 a.m., the Alaska Department of Natural Resources at 6:20 a.m., the North Slope Borough at 6:22 a.m. and the Environmental Protection Agency ("EPA") through a call to the National Response Center at 6:25 a.m.

Both of them stayed on location and were joined by other operators and they all worked to determine which of the three pipelines adjacent to the road had the leak. At 6:15 a.m. it was initially believed that the leak was on the Y/P LDF (large diameter flowline).

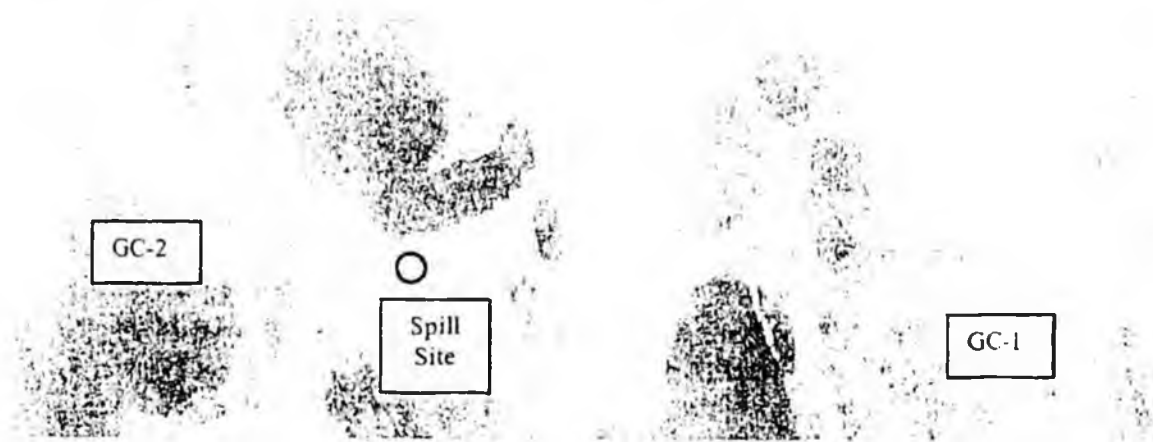

The GC-2 Area Manager called to have the pads shut in immediately. They then proceeded to shut down the Produced Water line from GC-1 at 6:27 a.m., which took less than 30 seconds for the pressure to bleed off. Finally, at 6:47 a.m., the GC-2 Area Manager called for GC-2 to be shut down which took approximately 10 minutes, and at 6:49 a.m., the block valve that isolates GC-2 from the Oil Transit line was shut in. The flow immediately ebbed and by 9:00 a.m. the leak had stopped.

C. HISTORY OF THE GC-2 OIL TRANSMISSION LINE

1. Background

The GC-2 Oil Transit Line runs from GC-2 to Skid 50 as shown in the following schematic:

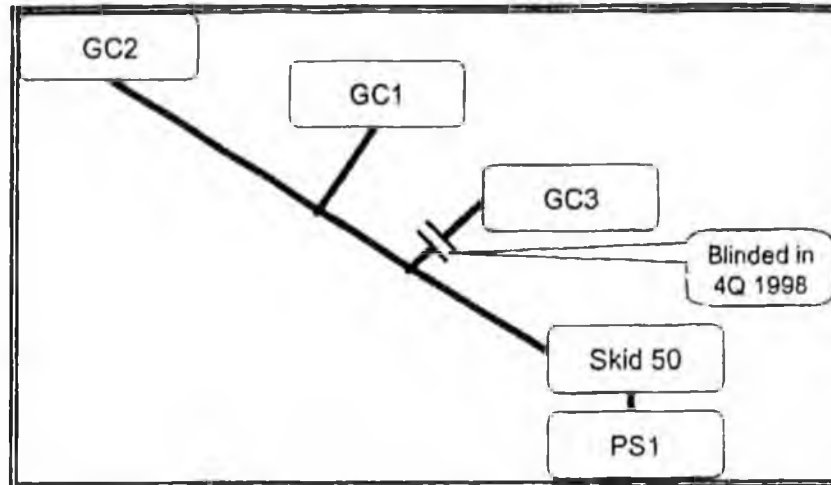

The pipeline is continuous but is divided into three segments as follows:

GC-2 to GC-1	~16,573 feet (OT-21)
GC-1 to GC-3	~11,420 feet (OT-13)
GC-3 to Skid 50	~13,881 feet (OT-31)
Total:	~41,874 feet (7.9 miles)

Design and relevant operating data are shown in the following table:

Outside Diameter (OD – inches)	34"
Nominal Wall Thickness (inches)	0.375" (3/8 ths of an inch) ± 12% Tolerance
Material Specification:	API 5L X52 (standard material)
Design Code	ASME B31.4
Year of Commission	1977
Design Pressure	740 psig
Current MAOP	500 psig (line was de-rated in the late 1990's as a result of corrosion in the Skid 50 by-pass line)
Typical Operating Pressure	< 100 psig
Typical Operating Temperature	110-130 F (exit dehydrators at GC2)
Fluids	Sales Specification Crude Oil: <ul style="list-style-type: none"> • BS&W 0.35% • Final Separator 14-16 psig

2. Line Integrity Overview

The BPXA corrosion inspection program is summarized below and is described in more detail in Section F of this report and in Appendix C.

Internal corrosion: The threat of internal corrosion in sales quality crude oil lines is commonly thought of as low because most of the water and gas has been removed from the fluids at the gathering centers. The risk is increased with (1) decreased flow rate and (2) increased BS&W, which allow water pockets to build up with time. Line condition pre leak is discussed in more detail in the corrosion and inspection section.

External corrosion: The threat of external corrosion is similar for all of the piping in the Prudhoe Bay field. Moisture from rain, melting snow or dew has the potential to migrate into the insulation which provides the right conditions for oxygen attack. The hotter the piping, the higher the risk. On this line the risk is generally considered to be lower than other areas of the field because:

1. The 3-piece design of the insulation does not trap water like some other designs do
2. The pipeline has a corrosion resistant coating in the cased sections

Corrosion Coupon & Probe Monitoring: Corrosion monitoring coupons are located in GC-2, GC-1 and at Skid 50 which see representative fluids entering the pipeline. All are below the target of less than 0.002 inches (2 mils) per year target.

Inspection Programs: The following inspection programs are in place for the GC-2 to GC-1 segment of the pipeline.

Inspection Program	Primarily Looks For:	Frequency	Number of Locations
Corrosion Rate Monitoring (CRM)	Internal Corrosion	Biannual	9 - Formally Established in September 2005
Comprehensive Program	Internal Corrosion	Annual	~50
Cased Piping	External	Depends on findings	14 out of 16. Casings. Plan is to permanently install on all.
Walking speed - Visual	External Problems	5 years	Whole Line
Intelligent Pigging	Internal & External Corrosion	Every 8 years (1990, 1998, was scheduled for April/May 2006)	Entire Line

A recurring risk based inspection program has been determined to be the best measure to identify equipment at risk. Prioritization of inspection surveys is determined by average temperature of the equipment, age of equipment or the last time a complete screening process was completed. Cased piping examinations are achieved through in-line inspection or relatively new non-destructive examination (NDE) technologies such as guided wave and electromagnetic inspection.

3. OT-21 Pressure Derating and 1998 Smart Pig

Management of Change (MOC) 97354382, dated July 24, 1997 formally derated the GC-2 Oil Transit Line to 500 PSIG per PMP # 97-088, dated July 2, 1997. The recommendation to derate the entirety of the line was based on both internal and external corrosion at the Skid 50 by-pass and a calculated MAOP of 572 PSIG on the by-pass section of the line. The lowest calculated MAOP for the OT-21 segment was 653 PSIG. However, the entire line carried the derating of the lowest calculated MAOP – that of the Skid 50 by-pass loop. The MOC was implemented around April 1, 1998 and recommended that the line be smart pigged that summer. That recommendation was acted upon and the line was pigged in the summer of 1998.

The 1990 smart pig run noted nothing of significance for the oil transit line. The 1998 smart pig run on the other hand showed moderate internal and external corrosion. The smart pig identified many areas of both internal and external corrosion on the OT-21 segment of the oil transit line of between 30% and 50% wall loss. The accuracy of the smart pig data was confirmed with follow-up UT inspections. The 1998 smart pig run also identified six specific areas inside this caribou crossing where internal corrosion pitting was occurring. Percent wall loss at these six locations in this particular caribou crossing showed a relatively low line wall loss of between 5% and 25% (B and C rankings). The leak location was one of these six locations and had a wall thickness loss of 9% in the 1998 pig run.

In September 2003, the decision was made to abandon the skid 50 bypass line. However, as a result of the 1998 smart pig run and the yearly data that had been gathered on the OT-21 segment, the decision was made to keep the line rated at 500 PSIG instead of rate it back upwards. Condition of the OT-21 line pre-leak is discussed in more detail in later sections of this report.

D. PRODUCTION OPERATIONS

1. Production Operations

Sales quality crude oil from GC-2 is transported to TAPS Pump Station 1 (PS-1) via the GC-2 to GC-1 (OT-21) oil transit line. Operational factors affecting this line have been identified as pressure or flow rate upsets, changes in production fluid quality relative to viscous oil production, and a reduction in fluid velocities due to overall reduced oil production since field startup in 1977. These factors combine to create the production operational parameters presented in this report.

2. Production Upsets

Electronic data retrieved from the Production Control computer system and graphed below indicates that normal operating parameters were present prior to the leak discovery. The only item of note recorded from February 16th thru March 2nd occurred during the shut-in process when pipeline pressure increased from normal operating pressure (approx. 80 PSI) to 209 PS.

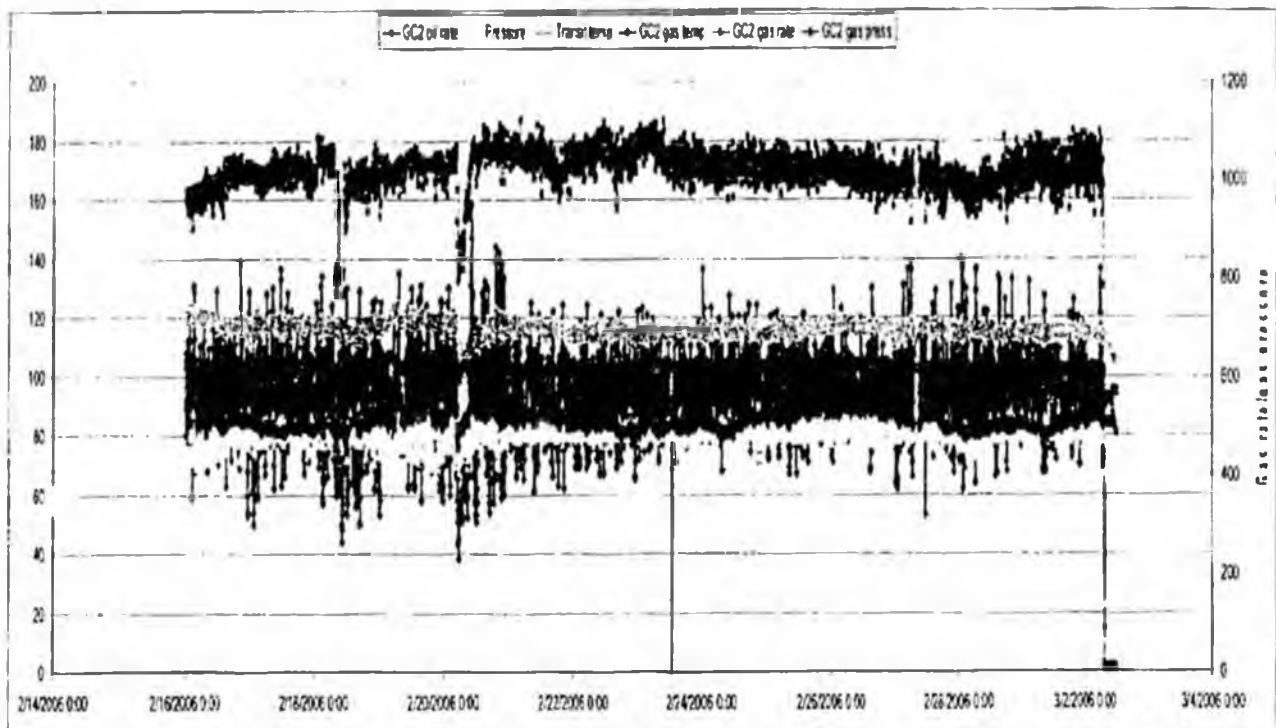

Chart data ranges

Pipeline Pressure	Fluid Temperature	Flow Rate
63-91 PSI	104-126F	38-158 MBPD

3. Viscous Oil Production

Electronic data collected during the investigation and graphed below documents an increase of viscous oil production at GC-2 from approximately 1,500 BPD in January, 2000 to a production high of 16,098 BPD on October 30, 2005. GC-2 produces more viscous oil than any other facility on the North Slope and today represents approximately 15% of total GC-2 production.

The increase in viscous oil production at GC-2 has, however, resulted in an increase in Basic Sediment and Water (BS&W) entrained in the production fluids as they leave the GC-2 facility and are carried through the OT-21 line.

Percent of Viscous Oil of Total Production

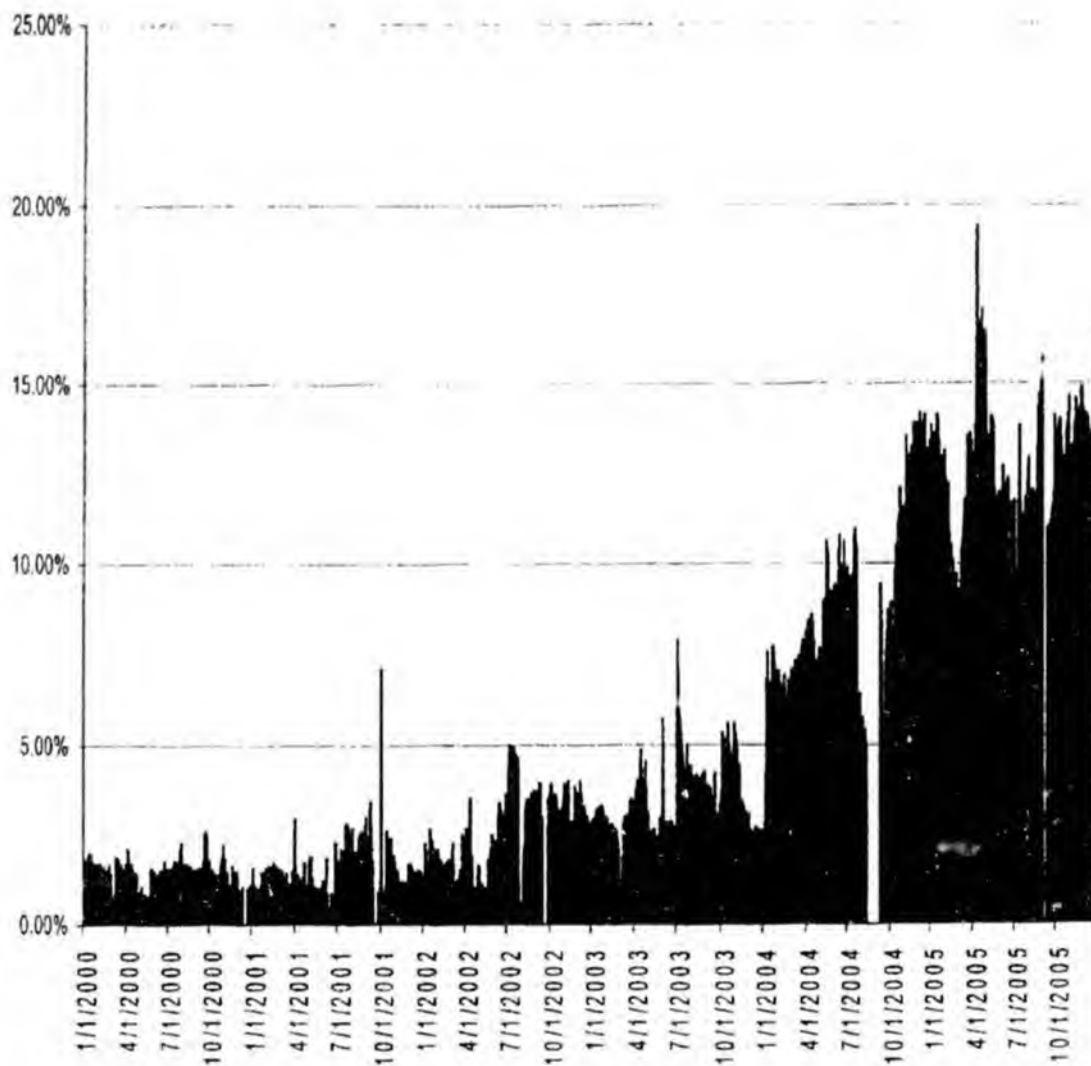

The electronic BS&W statistical data collected between 1/1/2000 through 2/28/2006 is graphed below and indicates a steady increase in mean BS&W as viscous oil production rates increased through GC-2.

Viscous Production vs. BS&W

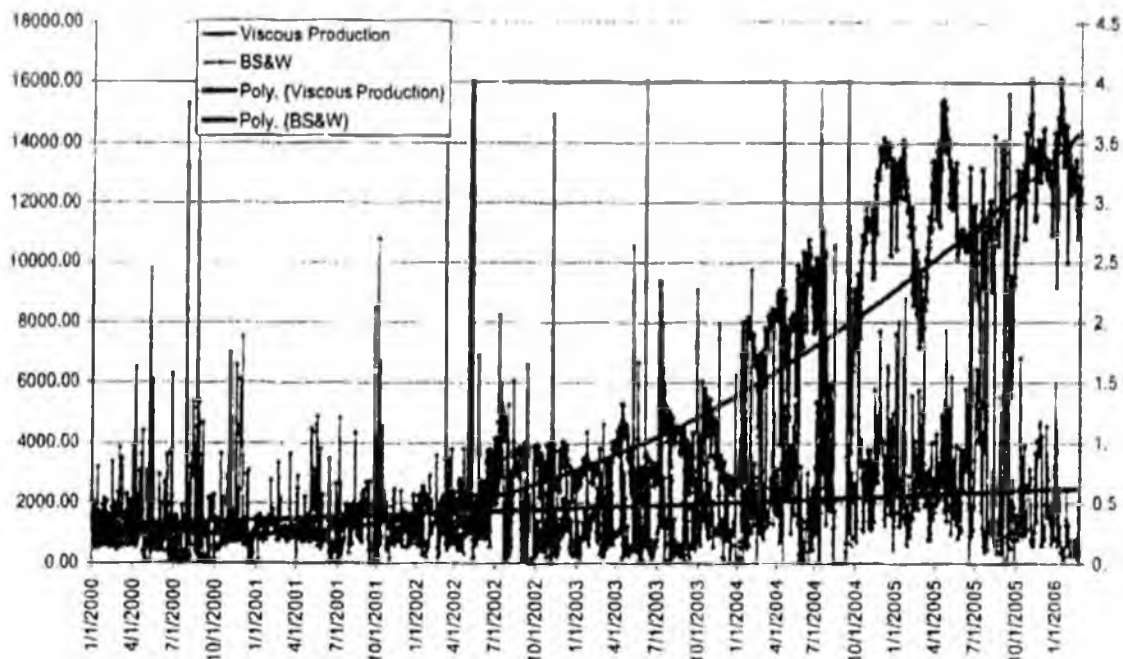

4. Production Rates

Prudhoe Bay oil production output has fallen by nearly 75 percent from its peak in 1987. As discussed and diagrammed below in Section F of this report, the resultant decrease in production of oil through GC-2 has reduced the overall flow rate of oil in this segment of the Oil Transit Line by nearly a factor of four.

E. PRUDHOE BAY LEAK DETECTION SYSTEM

1. Summary

The Prudhoe Bay leak detection system covers oil transit lines from all of the production facilities at Prudhoe Bay and Lisburne to PS-1. As described below, the system is divided into individual segments for purpose of leak detection. The OT-21 line from GC-2 to GC-1 is termed segment 3 and the line from GC-1 to Skid 50 is termed segment 4.

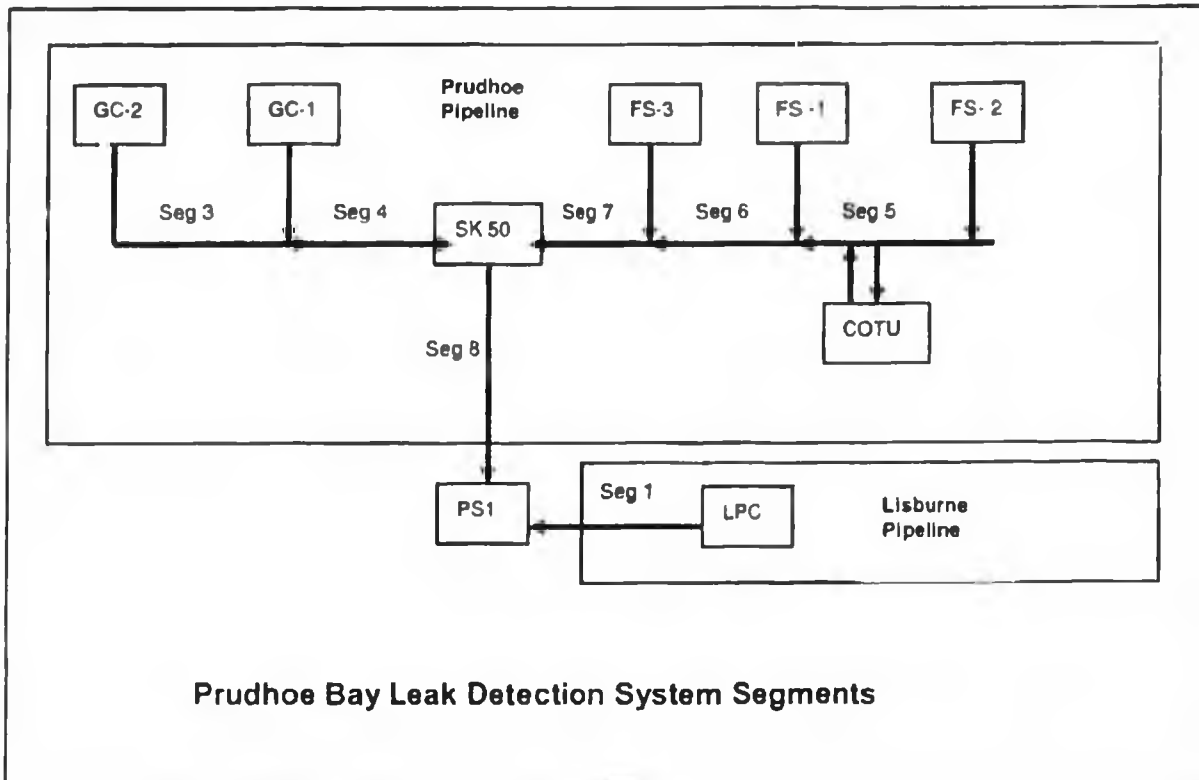

The leak detection system works by using a daily mathematical accumulator to measure positive and negative volumes between the meters at the beginning and end of each segment. For segment 3, the daily accumulator looks at the daily volume measured at the GC-2 sonic meter minus the daily volume as measured at the GC-1 sonic meter. For each segment, four alarm points are set: high/high, high, low and low/low. The high/high alarm set point for the system is set at approximately 0.5% of the average flow rate over a 24 hours period. For segment 3, the high/high alarm point is 440 bopd. Following is a graph of the daily accumulator rates for segment 3 for the week preceding March 2, 2006.

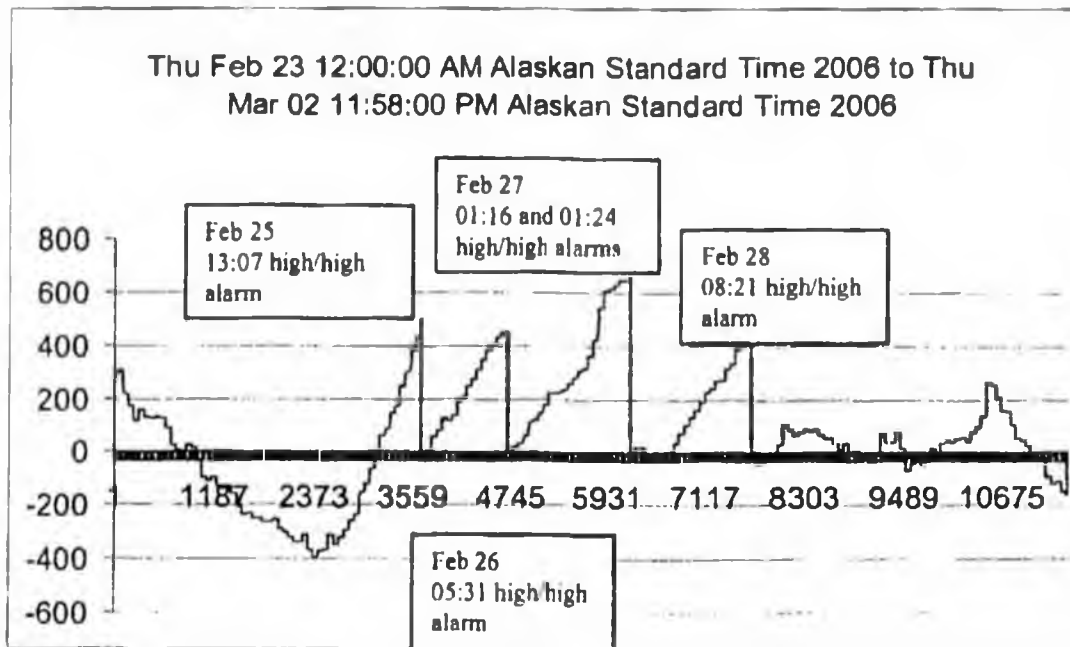

High/high alarms were noted by the automation engineer in their Leak Monitoring Tuning Log on February 25 through February 28. The Eastern Operating Center (EOC) Specialists, who monitor the alarms, also keep an event message log which confirms the high/high alarm readings on the times noted above. As shown in the preceding graph, the magnitude of the high/high alarms ranged from 440 bopd to 600 bopd. Starting on February 25, the notes in the Leak Monitoring Tuning Log note that GC-2 had been producing water on a regular basis and that segment 4 was mirroring negative readings as shown in the following graph.

GC2 Segment 3 and 4 Leak Detection Data

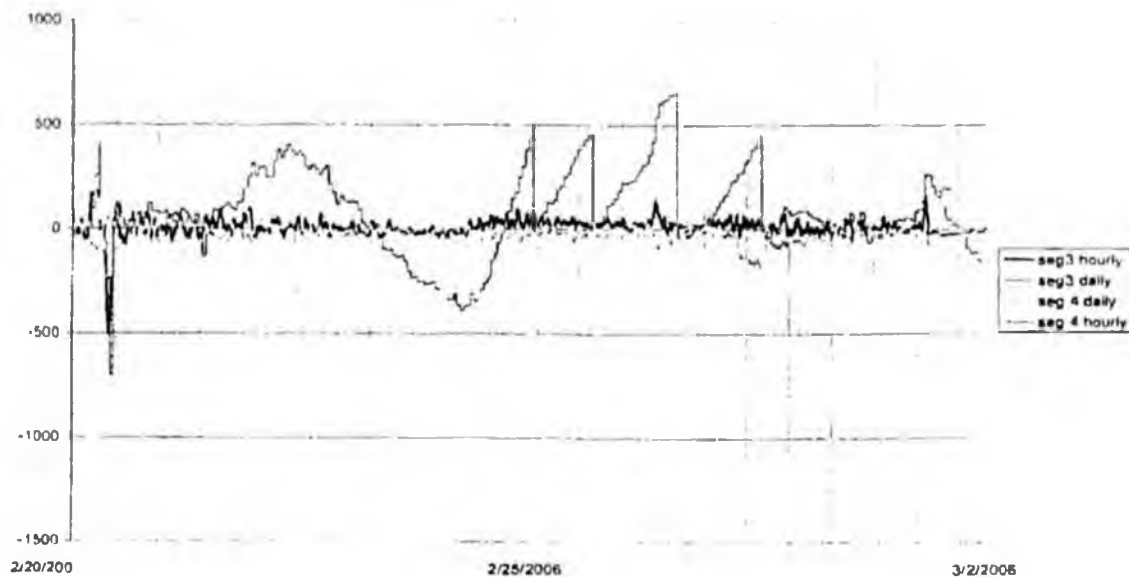

Based on the known GC-2 BS&W upsets that were occurring and the fact that line 4 was mirroring segment 3, the Leak Monitoring Tuning Log system states that the readings were interpreted as an error in the meters and both segment 3 and 4 were reset on each of these days (13:07 on the 25th; 06:49 on the 26th; 07:45 on the 27th; and 08:24 on the 28th). Our conversations with the automation engineers and the EOC Specialists who monitor the leak detection system confirm this statement. During this timeframe a tuning adjustment was also made to the leak detection system at 08:12 on February 28th. There was no high/high alarm detected on March 1 or March 2.

To try and determine how long the leak may have been occurring and at what rate, the rate of pressure bleed down after GC-2 and OT-21 were shutdown was used to estimate an equivalent hole diameter of 0.4 inches. An impression of the actual hole in the pipe measures roughly 0.25 inches by 0.5 inches. The equivalent diameter of this hole approximates the 0.4 inches calculated from pressure bleed down data. Based on this equivalent diameter, it is estimated that the maximum leak rate could have been in the range of 1000 to 1300 bopd at an operating line pressure of circa 80 psig. On March 9, 2006, the Unified Command released a joint estimate with an agreed upon estimated size for the spill of 4,800 barrels plus/minus 33 percent or between 134,783 gallons and 267,555 gallons. Based on the mean estimated spill volume of 4,800 barrels, the leak is estimated to have been going for at least five days. As a result of shutting down the GC-2 flow to GC-1, there was a pressure spike in the line that went to 239 psi for a short duration. This could have also impacted the final hole size. In consideration of this pressure spike, the fact that the hole most likely grew from the inception of the leak, the fact that insulation around the pipe would have caused a flow restriction and the uncertainty of how much of the final hole size may have been created as a function of removing the insulation, it is very likely, although impossible to prove, that the majority of the leak was most probably occurring at rates less than 1000 bopd.



2. Detailed Description of the Prudhoe Bay Leak Detection System

The Prudhoe Bay leak detection system is designed around a 1% detection threshold over a 24 hour period and utilizes either sonic flow or turbine flow meters that compare the flow rate into a given segment of pipe versus the flow rate out of that segment of pipe. The 16,573' of 34" line between GC-2 and GC-1 is referenced as Segment 3.

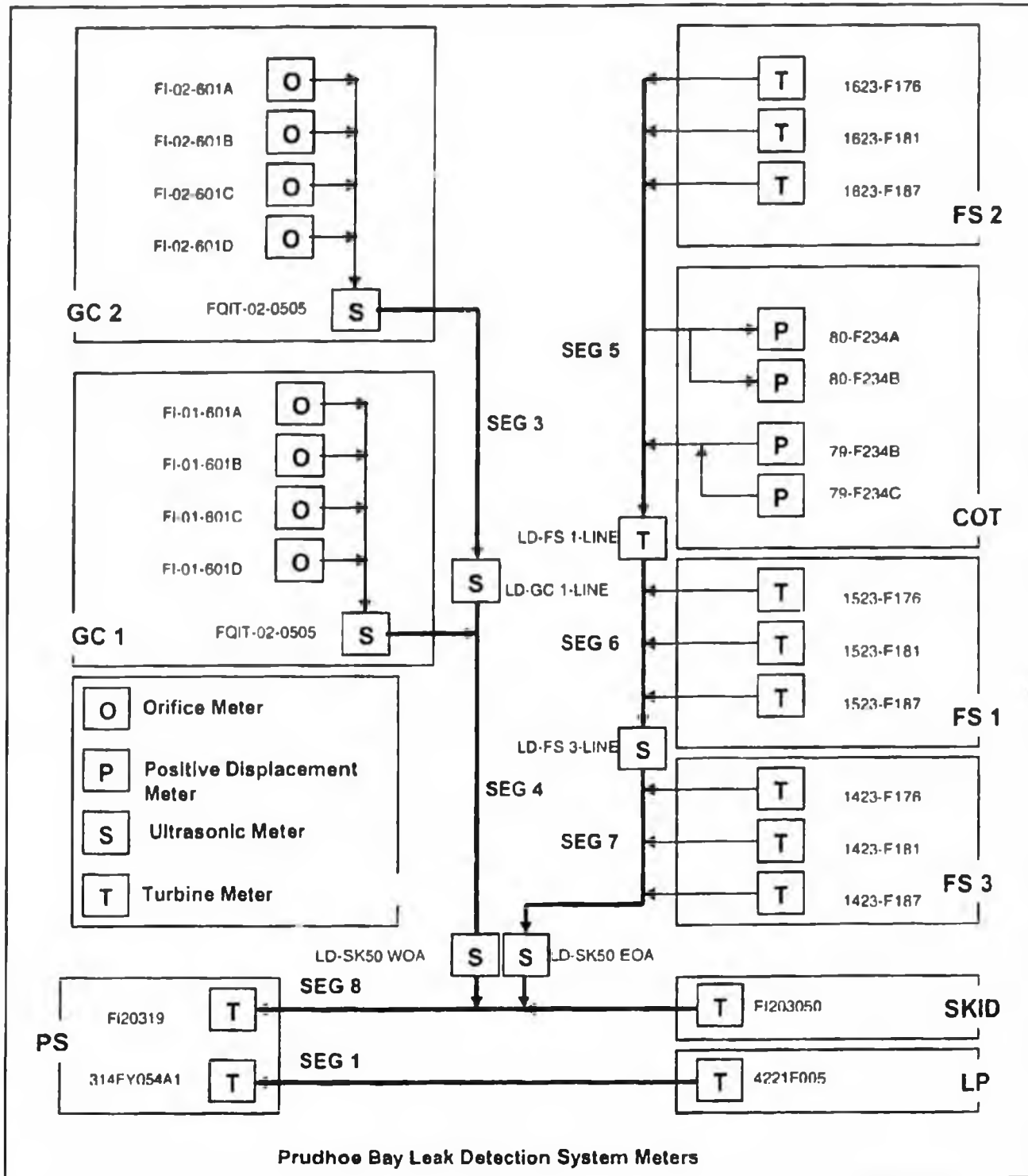

Theoretically, with no process fluctuations at GC-2 and no leaks in the pipeline, the measured flow rate at the sonic meter at GC-1 should be identical to that of the rate at the sonic meter measured at GC-2. Practically this is not the case. Due to process upsets (BS&W) and the non-steady state nature of the process, leak rates of less than 1% may not be detected by the system. As a result, it is designed to identify a 1% leak over 24 hours by use of a mathematical accumulator that adds up the delta of measured flow rates (GC-2 minus GC-1). It is also worth noting that the high-high alarm is set at a leak rate of approximately 0.5% to add a level of insurance to try and act on an event more quickly than if set at 1%. How the system works is that a positive accumulator number would indicate less oil coming out of GC-1 than what is going in at GC-2 and conversely, a negative accumulator number would suggest more oil exiting GC-1 than what is entering at GC-2. The graph below shows a week long history of minute by minute readings of GC-2 minus GC-1 for the week prior to the spill.

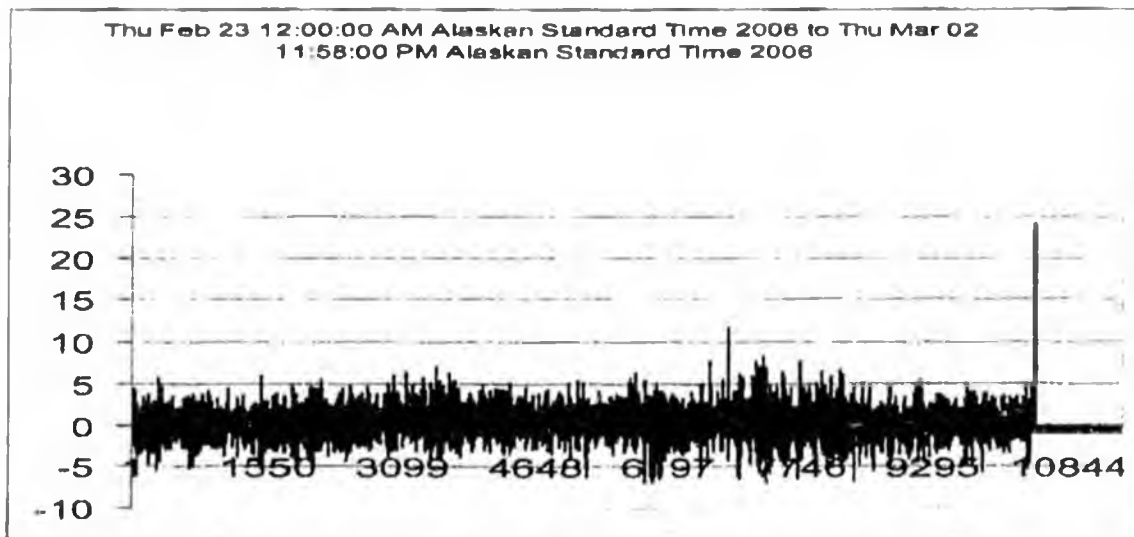

The graph illustrates a continual swing of positive and negative readings, with the absolute swings being in the 4 barrel per minute range. At 4 barrels per minute, this is the equivalent of 5760 bopd or just under 6% of a 100,000 bopd nominal flow rate.

To compensate for these dynamics, the ups and downs are smoothed using the accumulator and are looked at on an hourly basis as shown below over the same timeframe.

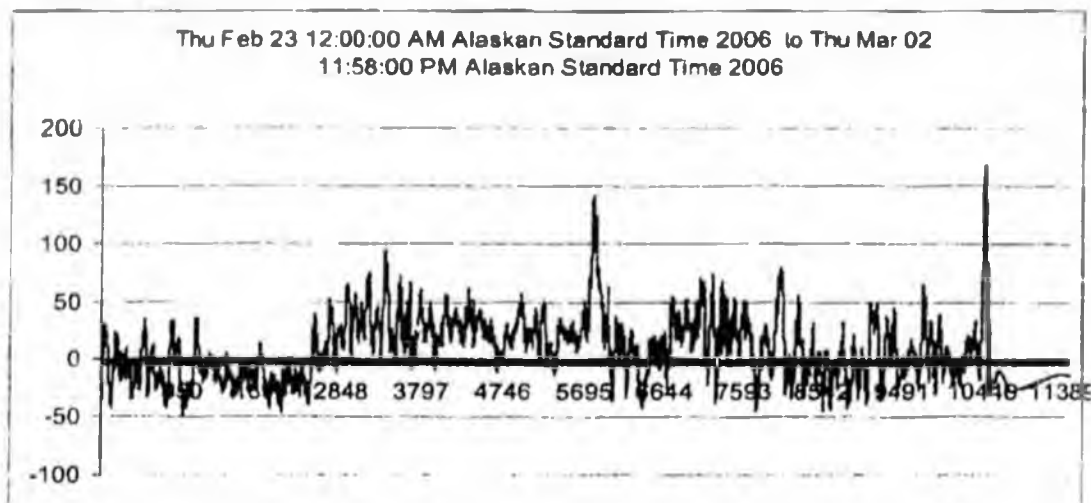

This graph still shows quite a variation in both negative and positive swings in the system on an hourly basis. As a result, it takes one further smoothing over a 12-24 hour period of the accumulated data to detect a small leak.

The graph below illustrates the uncorrected delta in daily meter readings from September 2005 to March 2, 2006.

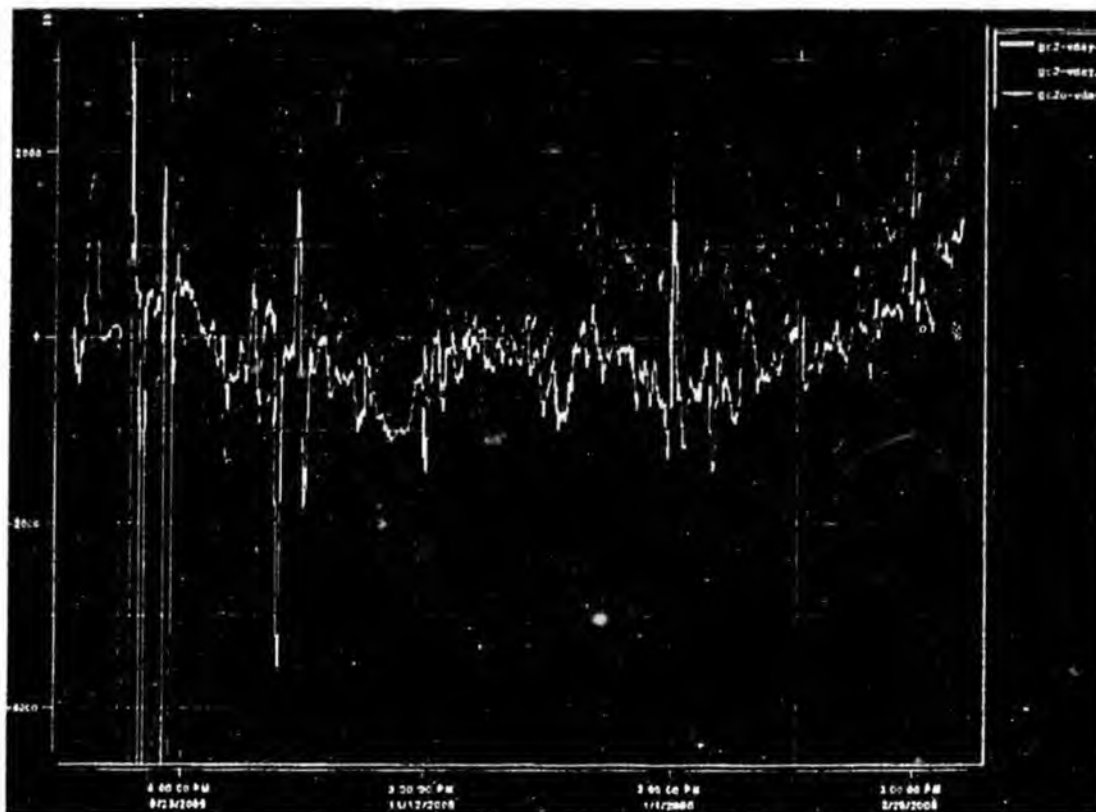

This graph shows that there are three meters at GC-2: orifice plate meters and two sonic meters. All measure the meter readings at GC-2 minus the readings at GC-1. The blue curve is the delta between the summation of the orifice plate meters and the sonic meter at GC-1; the white curve is the delta between the first sonic meter at GC-2 and the sonic meter at GC-1; and the red curve is the delta between the

second (newer) sonic meter at GC-2 and the sonic meter at GC-1. Note the magnitude of the differences between the three sets of meters is in the 1000 to 2000 bopd range. The spikes are usually associated with some sort of process upset. When this happens the EOC Specialists follow the Leak Detection Monitoring and Response Procedure and the systems and procedures outlines in the GPB Leak Detection System Overview, both of which are attached in Appendix C, to evaluate what is happening in the plant and the line. As described in those documents and discussed below, they must continually reset the accumulator and work to re-tune the meter factors for improved accuracy.

In 2005, BPXA evaluated the Prudhoe leak detection system to see if it could meet a 0.5 % leak detection threshold being considered by ADEC in a proposed rulemaking. The analysis concluded that meeting a 0.5 % leak detection threshold is not feasible. Nonetheless, as stated above, prior to the leak the system was set to alarm at approximately 0.5%. The 2005 analysis also determined that segment 3 has a high number of false alarms and a lot of unsteady state conditions – more than any other segment. Most of the false alarms are ruled out as process upsets due to high water content in the exported crude and the mirroring of a neighboring segment of pipe with negative readings. In the absence of these two facts, a request is made for the pipe to be either driven or flown over. According to the Leak Detection Monitoring and Response Procedure, it is the responsibility of the EOC Specialist to make this call, in consultation with the automation engineer, the Leak Detection Technical Authority, and other available resources. Below is a summary of the high and low alarms and number of resets and retuning that occurred from July 2005 through February 2006.

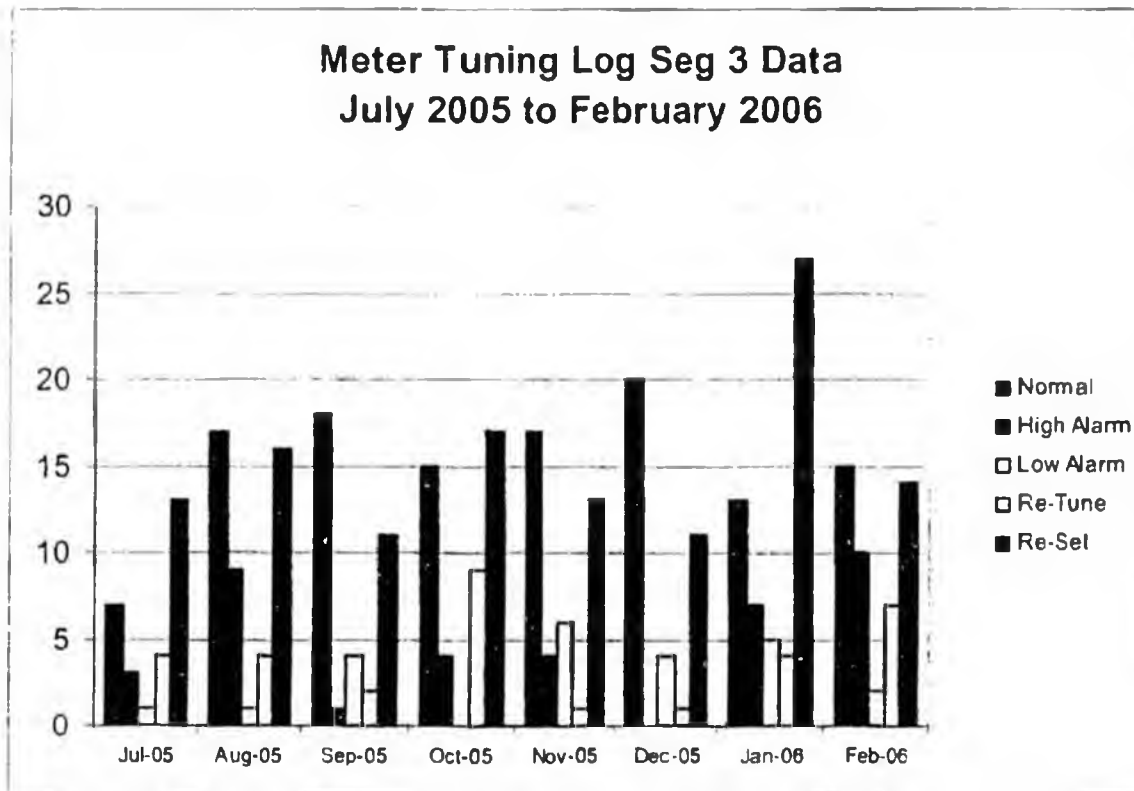

In summary, based on the minute by minute flow rate fluctuations, known process upsets and fluid composition changes, it is a challenge, if not next to impossible to detect instantaneous leaks of less than 1%. As a result, in order to detect a 1% leak, it will require 12 to 24 hours at a minimum to confirm the trend. Even then, because of the false alarms associated with the system in general and long term process upsets in particular, leak detection at the 1% threshold would be challenged.

F. CORROSION INSPECTION PROGRAM

1. Overview

The best source of information on the BPXA corrosion inspection and monitoring program is the publicly available Annual Report for the Year 2004 that BPXA submitted to ADEC in March 2005 on its Commitment to Corrosion Monitoring. This was the 5th such Annual Report and provides a detailed look on a yearly basis of BPXA's corrosion management and monitoring program for non-common carrier pipelines on the North Slope. Its contents reflect the Corrosion Work Plan jointly agreed to between BPXA, ADEC, and ConocoPhillips in 2000 as well as feedback from ADEC on previous Annual Reports and the twice-per-year meetings with ADEC on BPXA's corrosion inspection and monitoring program. Both the Work Plan and Appendix 3 to the March 2005 Annual Update, Corrosion Management System, are included in Appendix C.

Following is a high level summary of the program with an emphasis of those components of the program to better understand the internal corrosion activity in OT-21 and factors that have affected the recent and sudden increase in the rate of corrosion activity. Specifically, we look at:

- Internal condition of OT-21 pre leak
- Factors that affect internal corrosion of OT-21
- Known factors and actions taken

2. Pre-leak Condition of OT-21

Historical and current inspection programs provide insight into the pre leak condition of OT21.

- 1990 Smart Pig Inspection: OT-21 was inspected via a Pipetronix first generation (P1) smart pig in 1990. The following Table summarizes the results of that inspection.

1990 Smart Pig Data

Wall Loss	Indications
0-20%	22
20%-40%	30
40%-60%	6
>60%	0

CIC followed up the 1990 smart pig with manual UT (Ultrasonic Thickness) measurements to verify the smart pig data. The UT data showed a maximum loss of 32% with a minimum remaining wall of 0.265 inches. According to the UT results, the smart pig had significantly overestimated the amount of damage to OT-21.

- 1998 Smart Pig Inspection: OT-21 was again inspected using a Pipetronics smart pig (Generation 2) in 1998. As can be seen from the following figure, the 1998 smart pig run found quite a few more corrosion indications than were found in the 1990 smart pig run.

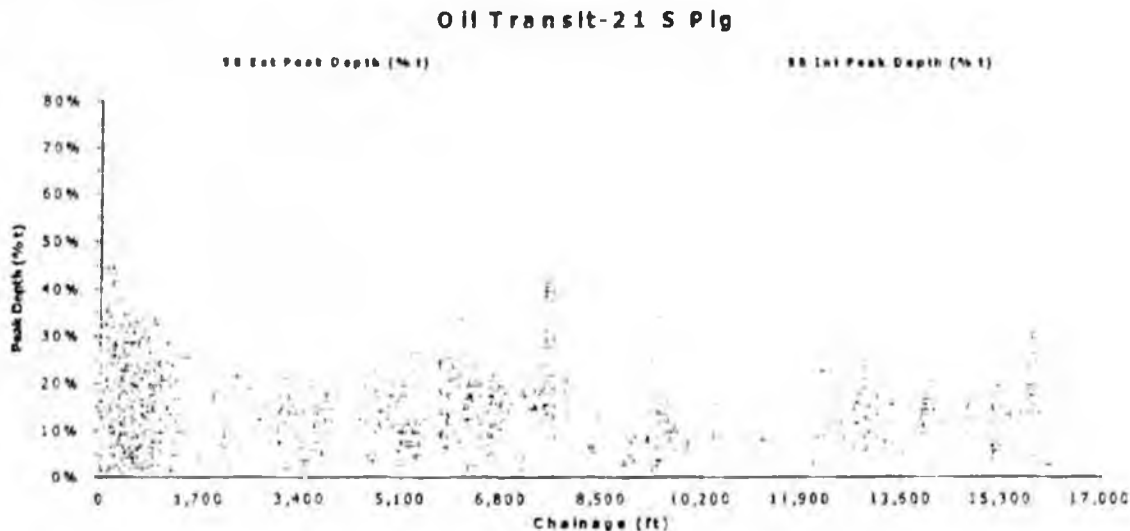

According to the 1998 smart pig run, the maximum internal corrosion loss was approximately 50% of the wall (corresponding to 0.187 inches wall remaining). As in 1990, the 1998 smart pig run was followed up with manual UT measurements. Unlike 1990, however, these follow-up manual UT measurements largely confirmed the results of the smart pig. The results of both the smart pig and UT inspection indicated that there had been continuing internal corrosion damage between 1990 and 1998. However, while experiencing some corrosion, OT-21 was well within the BPXA "fit for service" criterion. The basic fitness-for-service criterion used by BPXA is ANSI/ASME B31G – 0.100 inch wall thickness or a thickness required for 105% MAOP (the specifics of the fit-for-service definition are discussed in greater detail in the above referenced Appendix 3 at section 3.3.5 to the 2004 Annual Update included in Appendix C).

The amount of wall loss at this particular caribou crossing at the site of the leak was reported to be 9% in the 1998 survey.

- Post 1998 UT Inspection program: No smart pigs were run between 1998 and the present. However, information on the condition of the line can be obtained from the UT inspection program results from 1999 to 2005. Those results from the UT internal corrosion inspections over this timeframe are shown below.

UT Inspection Data Summary OT-21 from 1999 to 2005

Year	Number of Locations Inspected	Number of locations showing corrosion activity	Maximum rate of corrosion activity MPY	Wall thickness at location with highest activity	Location # of point with highest activity	Min wall thickness of all locations reported	Location with min wall
1999	15	1	13	0.230	229	0.180	262
2001	21	0	0			0.180	262
2002	20	2	21	0.240	136	0.180	262
2003	21	0	0			0.180	262
2004	15	1	3	0.260	7532	0.180	262
2005	47	7	32	0.300	263	0.140	14168

MPY = mils per year. One mil = 0.001 inches of wall loss per year.

Note: There were no UT evaluations in 2000

Only a few points (4 out of 92) showed an increase in corrosion activity from 1999 to 2004. This indicates that corrosion was not highly active during this period. In addition, the fact that the location showing the highest increase in activity kept changing from year to year is further evidence of minimal and random corrosion activity. The sporadic rate increases during the 1999-2004 period did not give rise for concern since the locations at which they were measured could withstand many years of similar corrosion activity (rate) before becoming unfit for service.

Further evidence of low corrosion activity comes from the observation that during this time period there was no further wall loss at the location historically reported with the minimum wall thickness (most historic corrosion activity) on OT-21, Location 262 which remained at a constant wall thickness of 0.180 in.

Clearly though something began to change in 2005 when the data from seven locations inspected in September/October 2005 showed an increase and the corrosion activity was the highest it had been over the past six years at 32 MPY. As a result, the OT-21 section of line was put on a biennial rate monitoring program and a smart pig run was scheduled for 2006.

This sudden increase in corrosion rate is shown in the following table and shows a representative sample of the data from 2005 inspection locations including all of the locations that showed an increase in corrosion activity in 2005. More importantly, the results of the UT inspections that were just conducted after the incident have been compared to the last set of data for that same location.

OT21 Inspection Data with increases in 2005

Location	1998				1999				2000				2001				2002				2003				2004				2005				2006
	1Q	2Q	3Q	4Q	1Q	2Q	3Q	4Q	1Q	2Q	3Q	4Q	1Q	2Q	3Q	4Q	1Q	2Q	3Q	4Q	1Q	2Q	3Q	4Q	1Q	2Q	3Q	4Q	1Q				
111																															18		
112																																	
113																																	
115																																	
116																																	
117																																	
118																															12,220		
176																																	
234																																	
241																																	
261																															11,340		
263																																	
14167																															15,150		
14168																															20,140		
14169																															9,260		
14695																															7		

9/260 = 9MPY. 260 wall left at reading site
 ■ MPY from last point >30 MPY
 ■ MPY from last point <=20MPY
 ■ MPY Zero - no change in wall thickness
 □ indicates duration of inspection interval

What the above table shows is the status of a particular inspection point from one point in time to the next point in time that the location was inspected. As can be seen from the extensive and long term green and yellow bars, corrosion activity was very low for the majority of these locations through at least September/October 2005 -- the date of the last inspections that BPXA had for the line prior to the March 2, 2006 leak. In other words, the sudden increase did not begin to occur until sometime after the last date that measurements were taken in the fall of 2005. As already mentioned above, there was only one location shown in red above that was known prior to the spill – location 263. However, while not a concern on an individual location specific basis because it had 0.300 wall remaining, the collective picture did cause some concern and actions were taken to increase the frequency and nature of the review of the line as discussed above and in more detail below.

The remainder of the red bars are based on inspections done at that particular location after the leak. The post leak inspection data, i.e. all of the data collected in the past few weeks clearly shows that something has drastically changed as nearly all locations that have been UT inspected show a large increase in corrosion activity with measured rates in the 40-80 MPY range.

- Guided Wave UT: Road and Caribou Crossing Inspections

The May 2005 Annual Report discusses in detail the BPXA inspection program at buried road and caribou crossings on the North Slope. In particular, it describes the Guided Wave UT inspection program for these areas. A guided wave UT was recently conducted at this particular caribou crossing and another was just conducted after the incident. Neither of these inspections, however, shows evidence of internal corrosion on the pipeline. This is largely because the guided wave UT method mainly detects large volumetric metal loss. As a result, by design it is not as sensitive to internal pitting as it would be to large amounts of external corrosion which, prior to now have been viewed as the main corrosion threat on the North

Slope at cased crossings. BPXA is in the process of implementing a guided wave UT inspection program that will provide repeated scans over the same area that should be better able to detect changes in external corrosion activity. Without excavation and removal of the outer casing from the pipeline, smart pigging is the only accurate way to determine the condition of cased or buried pipelines with respect to internal corrosion. As stated above, a smart pig was scheduled for this line in 2006.

- Corrosion Coupon Data

The graph below shows data from corrosion coupons installed in the oil transit line between GC-2 and Skid50.

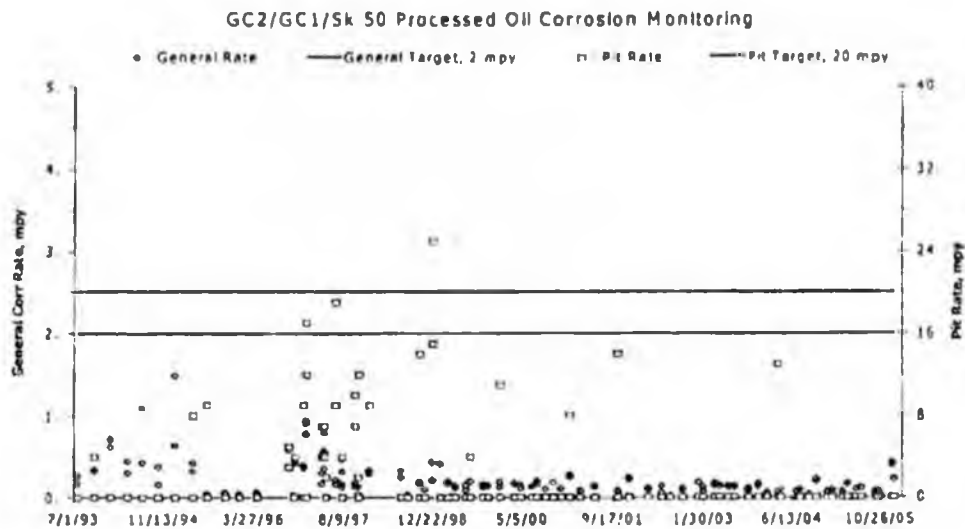

As can be seen from the graph, the coupon data are all well below the target corrosion rate of 2 MPY. Some slight pitting has been observed over the years, but nothing excessive. The coupon data does not show any evidence of increasing corrosion trend. This may be explained by the fact that the coupons are in the flow stream and the corrosion damage appears to be primarily located on the bottom of the line on certain uphill runs.

In summary, the above discussion indicates that there was existing pre-leak corrosion damage to OT-21 that was known to exist. However, the data also shows that the line easily met the "fit for service" criteria. The UT data also indicates that internal corrosion was largely under control until sometime between late 2005 and now. Neither guided wave UT at the caribou crossing nor corrosion coupons showed any indication of an increase in corrosion activity.

3. Potential Factors for Increased Internal Corrosion Rate

In an attempt to analyze what could have caused the rapid increased corrosion activity over the past six months, we looked at numerous factors that might have led to the sudden increase in internal corrosion activity observed after the leak.

- Water in the OT-21 Line

Water must be present in the line for internal corrosion to occur. The smart pig data from 1990 and 1998 shows that corrosion had occurred slowly over time, therefore water must have been present at sometime in the past. Likewise, the recent increased corrosion rates also would have required water.

To help with the analysis, we calculated the flow velocity of fluids through the OT-21 based on production rates from 1990 forward. Those historical rates are shown below in feet per second.

OT-21 Historical Velocities - fps

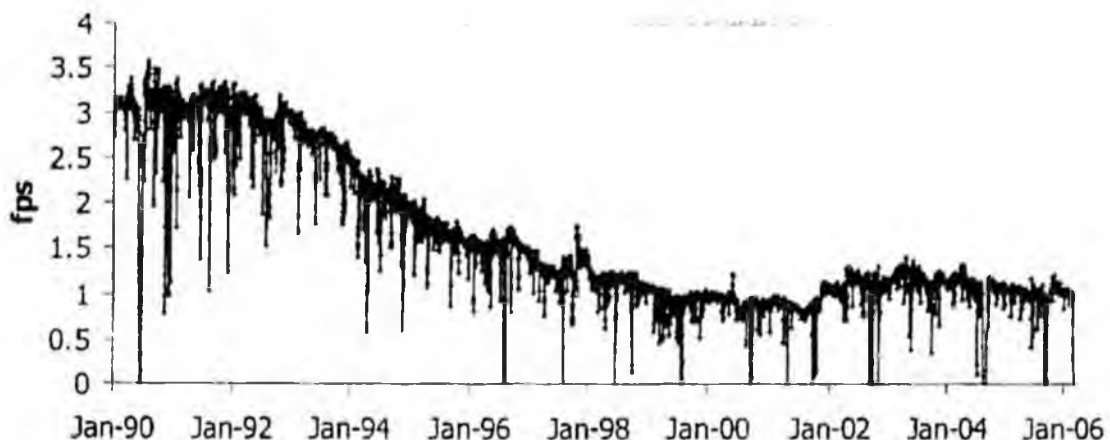

Next, we modeled the OT-21 pipeline and determined that a velocity of about 8 ft/sec would be required to sweep residual water from the line. This would be true even at various inclinations like that at the caribou crossing. Based on these two data points, we can conclude that with a velocity of 4 ft/sec or less, water has likely been present in the OT-21 line since at least 1990 and probably long before that given the fact that corrosion was found in the 1990 smart pig. Therefore, although Section D of this report shows the relationship between the increase in Viscous Oil production at GC-2 and the resultant increase in BS&W carryover into OT-21, water was present long before Viscous Oil although likely in lesser amounts.

- CO₂

CO₂ is widely present in Prudhoe Bay fluids and if uncorrected for can cause corrosion. However, the crude oil leaving the GC-2 production process is depressured to 15 psig in the last separation vessels. As a result, the fluids should be in equilibrium with CO₂ in the gas at that pressure. Corrosion predictions show that this amount of CO₂ would produce a corrosion rate of 8 MPY, far below that observed in the last six months on the OT-21 line.

- H2S

H2S is known to be present in the GC-2 inlet separators at 20 ppm and builds somewhat throughout the facility. However, by itself it does not reach levels that could cause the corrosion rates observed.

- Erosion

Erosion of the inside of the wall of a pipeline can and does occur in certain instances, especially where sediment is present. However, the velocities shown in the above graph for this line are much too low for erosion, even if increased BS&W and Viscous Oil "flour sand" is carried over into the OT-21 line.

- Water Chemistry

No significant changes were found in water chemistry or pH since 1995.

- Well Activities

No evidence was found of recent significant changes in well fracturizations or acidizing work upstream of GC-2.

- Under Deposit Corrosion

The pipeline was not directly opened up to view what is inside it at this location. As a result, there is no direct evidence for or against under deposit corrosion at this time. However, the mechanism associated with under deposit corrosion is usually a longer term corrosion issue and by itself would not be expected to suddenly increase and produce the rates observed.

- Corrosion Inhibition

In 2006, the annual budget for the BPXA Corrosion, Inspection, and Chemical (CIC) program was \$62 million, an increase of 80% from 2001. A large portion of that is spent on corrosion inhibitors to add to the produced fluids system. These corrosion inhibitors are water soluble and carry over in small amounts into the production facility and the downstream piping leading from it. The same would be true for GC-2 and the OT-21 line. BPXA enhanced its corrosion inhibition program in the mid-1990's and corrosion inhibitor usage has increased from 1.62 million gallons in 1995 to 2.71 million gallons in 2004. This increase is likely responsible for the reduction in corrosion activity observed in OT-21 after 1998. Changes in inhibitor or inhibitor carryover could affect downstream corrosion rates.

Records show that two corrosion inhibitors have recently been used -- Nalco 01VD121 (2002 to September 2004) and DVE4D002 (September 2004 to October 2005). The facility returned back to using Nalco 01VD121 in October 2005. While this fact alone might lead one to look into its potential impacts on the recent increases in corrosion rates, that fact is unlikely since it was used successfully from 2002 through September 2004 with no resultant increase in corrosion rate over that timeframe.

Inhibitor carryover was tested by Nalco on samples of produced water from GC 1, 2 and 3 and FS 1, 2 and 3 in February 2005. As shown below, this data shows GC-2 had the least carryover of corrosion inhibitor of the six facilities. At 17 ppm the amount was 30% of the average of the other GC's or FS's. Upstream inhibitor injection appeared normal at this time. This low level of corrosion inhibitor carried over into the OT-21 pipeline system could contribute to an increase in corrosivity of the GC-2 water in the line. The reason for this low level of corrosion inhibitor carryover is not totally known. However, facts suggest it could be the result of the additional solids brought in by Viscous Oil production into GC-2. Increased solids provide sites for adsorption of the corrosion inhibitor, which would then reduce the level of residual corrosion inhibitor in the water. Because of the increase in Viscous Oil production and the resultant increase in BS&W, GC-2 has had to experiment with various emulsion breakers to try and address the BS&W upsets. Because of the various chemical interfaces this too could have contributed to the reduction of corrosion inhibitor carryover.

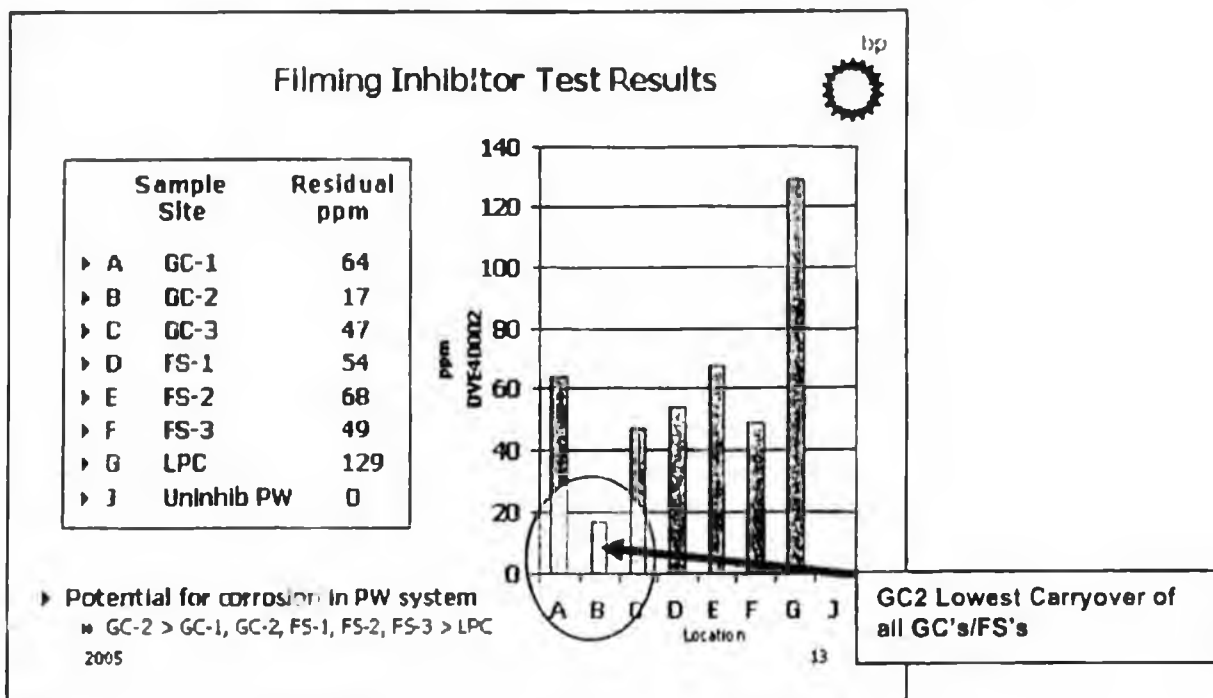

• **Bacteria**

Bacteria, particularly Sulfate Reducing Bacteria (SRB), are well documented to cause corrosion in oilfield equipment although their presence in sales quality crude oil lines is unexpected. However, bacteria can thrive in low velocity vessels and tanks, especially under deposits, sand, or sludge. Corrosion rates from SRB activity can reach 50-100MPY.

Some historical data exists on bacterial activity at GC-2 that shows some activity from 1990 to 1998 in inlet vessels. However, several recent events indicate that bacterial activity has increased at GC-2 and in the OT021 line.

Concerns about H₂S levels in 2005 prompted a sampling program around GC-2. Results shown below indicate that the inlet gas H₂S levels are fairly low, 20-30 ppm. However, gas samples taken at more downstream parts of the plant indicate a rise in H₂S. This indicates a rise in SRB levels through the plant vessels. A new set of samples has been taken to verify SRB activity and results will be available in early to mid-April.

GC-2 H₂S Sample Log Sheet

Location	PPM Result	PPM Result	PPM Result	Date	Sample Method
Gas Off B Slug Catcher	30	30	30	7/1/05	direct gas
Gas Off C Slug Catcher	20	20	20	7/1/05	direct gas
Water Off D Slug Catcher	140	140	140	7/1/05	gas off the water / shake & drake
Water Out of A Dehy	180	150	130	7/1/05	gas off the water / shake & drake
Water Out of B Dehy	50	30	30	7/1/05	gas off the water / shake & drake
Water Out of C Dehy	25	30	30	7/1/05	gas off the water / shake & drake
Water Out of D Dehy	275	350	325	7/1/05	gas off the water / shake & drake
Water Out of T-8512	600	400	400	7/1/05	gas off the water / shake & drake
Water Out of T-703	800	825	600	7/1/05	gas off the water / shake & drake
Vent Gas Blower gas	175	200	200	7/1/05	direct gas
Discharge off Booster Pump in 407	400	800	800	7/1/05	gas off the water / shake & drake
Discharge off Booster Pump in 402	275	350	300	7/1/05	gas off the water / shake & drake
Dirty Water Tank Gas Phase	175	225	200	7/1/05	direct gas

In addition to the inhibitor residuals mentioned above, Nalco conducted tests on GC-2 produced water on samples taken in February 2005 that showed GC-2 inhibitor carryover had the least affect on SRB growth of any of the production facilities tested. This is graphed below. The importance of this fact is that corrosion inhibitor, although not a biocide, is toxic to SRB's. As a result, a reduction in corrosion inhibitor carryover into the GC-21 line could have led to an increase in SRB activity in the line.

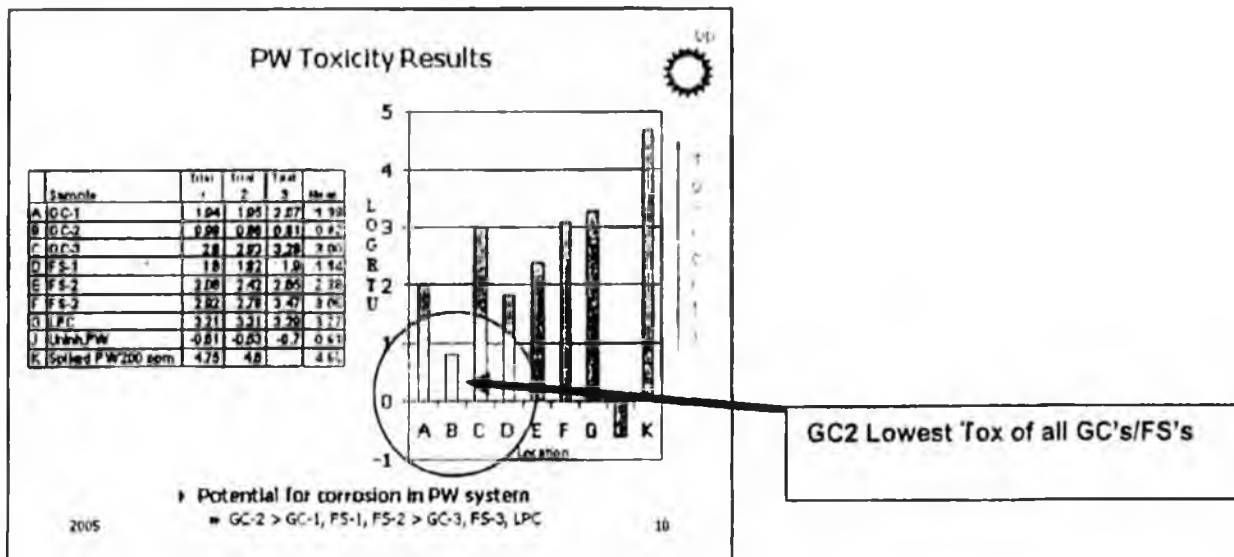

Another Nalco study in July 2005 showed that SRB activity was 10^4 col/ml at the oil-water skim tanks at GC-2. This is a relatively high level of SRB growth and was the highest of any of the GC's/FS's.

Other Chemical Changes: We also evaluated whether or not any other recent changes in production chemicals could have had an affect on corrosion activity or inhibitor carryover. Our inquiry identified two such potential chemical changes in GC-2. First, GC-2 uses a Champion product called X-1421, which is commonly referred to as "Pad Buster." It is used on occasion to break up bad emulsions in GC-2 vessels. This chemical has been in use since 2002 in GC-2 and other processing locations. Second, Viscous Oil production has made oil/water separation more difficult at GC-2 and Nalco brought on an emulsion breaker, EC2011A, in January 2000 to address the issue. This chemical was recently changed to VX8055 (also labeled as DVE4Z026) in 3Q and 4Q 2005 with good results – better oil/water separation – reported.

No changes in scale inhibitors were reported since 1Q04.

Some of the more pertinent facts from above are shown in the following timeline.

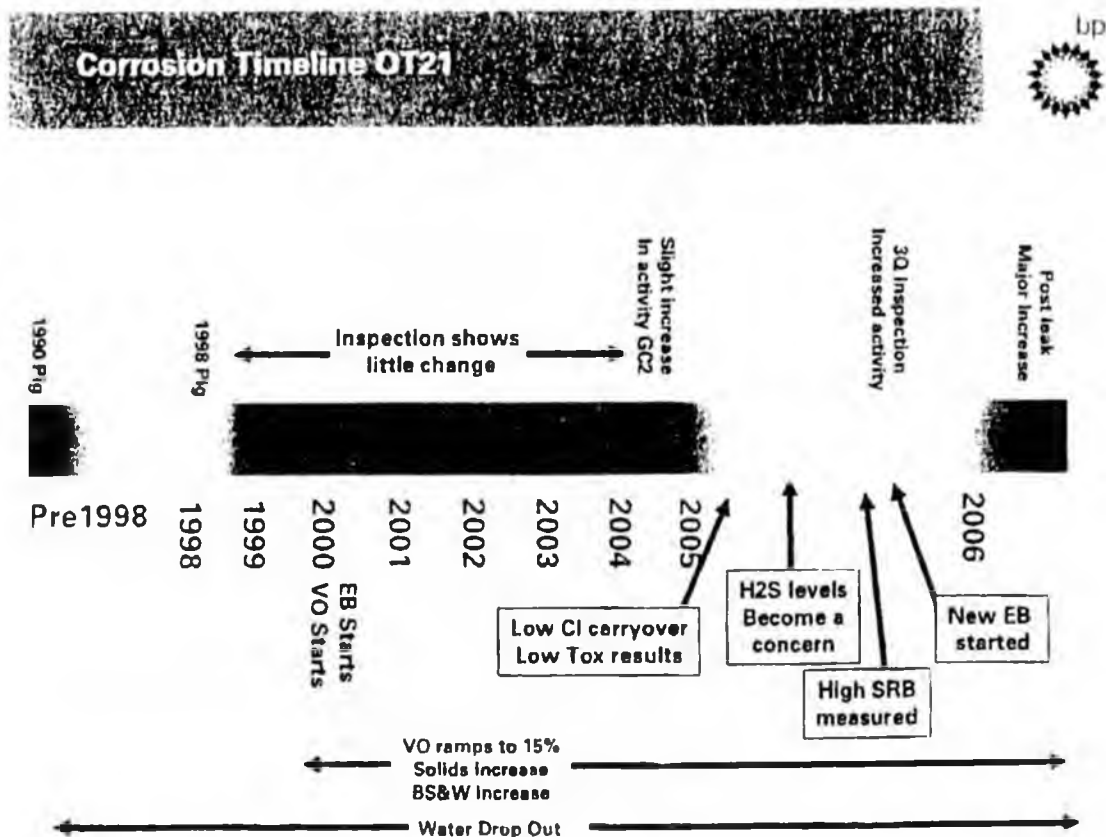

4. Conclusion

Much of the data collected in hindsight after the leak points towards an increase in SRB activity in GC-2 and the pipeline as a likely factor in the recent and sudden increase in corrosion activity. Data shows that SRB are present in GC2 as shown by the elevated H2S levels and the bacterial test results. The presence of bacteria combined with the demonstrated low carryover of corrosion inhibitor in GC-2 and the low toxicity test results increases the likelihood of this occurrence.

The lack of corrosion inhibitor carryover may be due to two factors. First, through adsorption on solids present in the GC-2 process trains as a result of Viscous Oil production and the resultant increase in BS&W and the fine "flour sand" that is produced. This would provide a large surface area for adsorption of the corrosion inhibitor. Second, by using emulsion breakers to promote oil/water separation, these chemicals could aid in removal of the active components in the corrosion inhibitor from the water. However, with respect to this latter point the low levels of inhibitor carryover at GC-2 were measured in 1Q05 well before the recent change in emulsion breaker.

The following Action Timeline attempts to document actions taken with facts known about the corrosion on the OT-21 line.

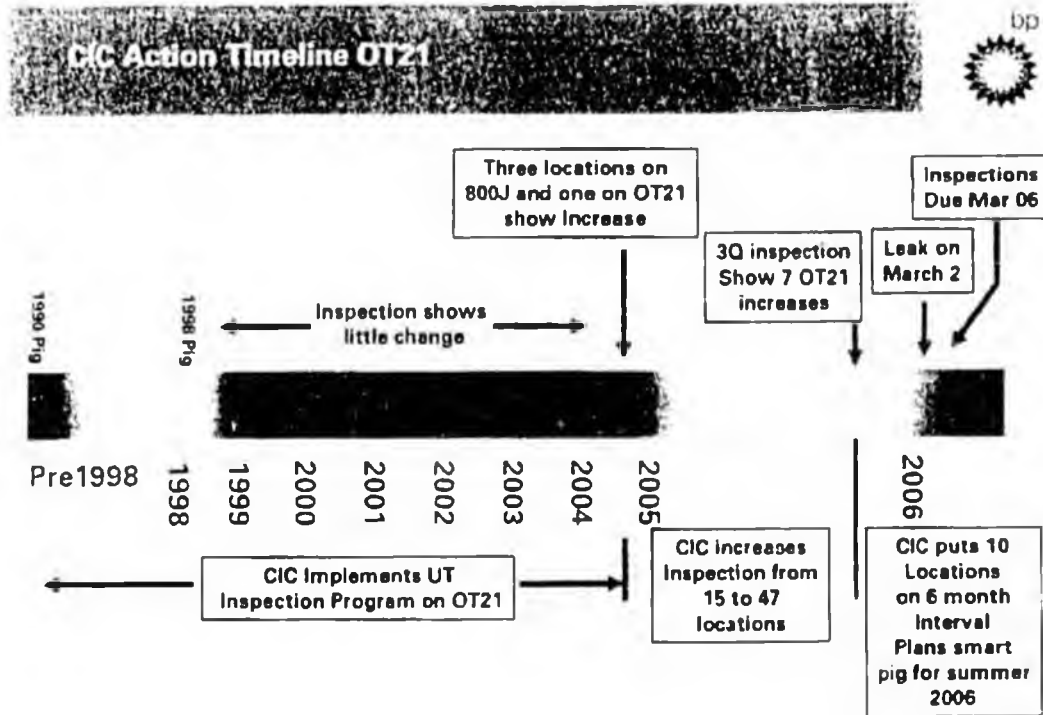

As discussed in detail above, there was very little change in the corrosion rates on the OT-21 line segment until the 2004 program data was reported in 3Q04. At that time, three locations in the 800j 24" line, the line that feeds into the OT-21 line at GC2 increased along with one location on OT21. None of these increases gave rise to concern about the fitness for service of 800J or OT-21. Based on these results, however, BPXA increased the number of inspections on the OT-21 segment from 15 to 47 for the year 2005 program. The results of that program in 3Q05 showed seven locations on the OT-21 line had increased corrosion rates. As a result, ten OT-21 locations were placed on a six-month inspection interval, as opposed to the previous 12 month interval, and the smart pig was confirmed for 2006. None of the data in either 2004 or 2005 indicated a concern for the "fitness for service" of OT-21.

The leak occurred March 2, 2006. The next round of bi-annual UT inspections for the ten locations was scheduled for March 2006. The smart pig was scheduled for 2006 as well. Since the leak, BPXA has conducted in excess of 2,500 UT inspections including over 1,800 on this line. This post leak inspection data clearly shows sudden and unexpected increases in corrosion activity since the last set of data was gathered in fall of 2005. Had the leak not occurred, either the next round of bi-annual UT inspections or the smart pig run would likely have detected this increase and actions would have been taken.

APPENDIX A
GC-2 Transit Line Spill – March 2, 2006
Sequence of Events (Timeline)

ITEM #/ CF	DATE/TIME	PIPELINE HISTORY EVENTS	CONDITIONS/COMMENTS
1.		P-L construction, etc... (need history)	
		SPILL IDENTIFICATION/REPORTING EVENTS	CONDITIONS/COMMENTS
2.	Thurs 3/2 0450	Tim Okonek (GC-2 Well Pad Operator) detected hydrocarbon smell while driving pipeline road between GC-2 and GC-1.	<u>Comment:</u> Because he was alone, Tim decided not to exit his vehicle and investigate, but to instead proceed to BOC to make notification.
3.	Thurs 3/2 0530	Tim Okonek arrived at BOC and advised Bob Wortham (GC-2 Lead Operator) and Shawn Croghan (GC-2 Area Manager) of the smell.	<u>Comment:</u> Tim also mentioned smell to Security guard "Beetle" Bailey
4.	Thurs 3/2 0535	Shawn Croghan (GC-2 Area Manager) and Pat Ramsey (GC-2 Well Pad Operator) departed BOC for GC-2 pipeline road. They drove slowly for approximately two miles, using the truck spotlight to illuminate the lines adjacent to the road, checking for hydrocarbon smell and indications of leak or heat plume. While passing the first caribou crossing from GC-2 end of line (heading east), Pat Ramsey thought he noticed a small heat plume. He stopped the truck and Shawn Croghan exited the vehicle and approached the pipelines. He was unable to see anything so he informed Pat Ramsey that he was going to climb up and walk on the snow covering the lines. He did so and observed an open snow cave with liquids running off what appeared to be the third pipeline in from the road. After removing himself to a safe location to make notification.	<u>Conditions:</u> In his written statement, Shawn Croghan reported that wind speed at the time was approximately 15-20 mph blowing almost directly downward in direction.
5.	Thurs 3/2 0558	Shawn Croghan (GC-2 Area Manager) called in Code Black (emergency spill response) to GC-2 and PCC.	
6.	Thurs 3/2 Approximately 0600-0615	Shawn Croghan and other operators worked to identify the source of the leak, as there are 3 lines adjacent to the road. At 0615 they thought that the leak was on the Y/P large diameter flowline (LDF). Shawn Croghan then initiated shut-ins of Y and P Pads, the produced water line between GC-1 and GC-2, and all of the remaining GC-2 process areas and well pads.	
7.	Thurs 3/2 0616	Y Pad and P pads shut-in	

8.	Thurs 3/2 0618	Mobile Command Center (MCC) is dispatched to scene and Comm Center notifies Shawn Croghan (GC-2 Area Manager) that staging area will be set up at Santa Fe Pad.	
9.	Thurs 3/2 0644	IMT activated and members notified to mobilize at IMT Center at PBOC (Prudhoe Bay Operations Center – Eastern Side of field)	
10.	Thurs 3/2 0646	All wells on H pad and J Pad are shut-in by Operations	
11.	Thurs 3/2 0647	All wells on M, N, R, S, U, W and Z Pads are shut in by Operations	
12.	Thurs 3/2 0658	SDV-01-0502 valve (oil from GC-2 to GC-1) shut in by Operations	
13.	Thurs 3/2 0708	SDV-02-0503 valve (transit oil to GC-1) shut in by Operations	
14.	Thurs 3/2 0806	First FLIR flight readied for departure	
15.	Thurs 3/2 0823	Alaska Clean Seas (ACS) mobilized	
16.	Thurs 3/2 0859	ICS confirms that GC-2 transit line pressure = 0	
17.	Thurs 3/2 0930	Verbal approval received for tundra travel	
18.	Thurs 3/2 0935	Line size verified at 34" standard	
19.	Thurs 3/2 1100	ADEC representative Gary Evans arrives on site	
20.	Thurs 3/2 1100	Alaska Clean Seas (ACS) confirms oil on north side of pipeline	
21.	Thurs 3/2 1500	Second FLIR en route	
22.	Thurs 3/2 1800	Unified Command in place	

APPENDIX B

List of People Interviewed

Individuals Interviewed

- Hal Tucker, Production Optimization TL
- Tim Clark, Production Control Lead, Involved in shutting down GC-2
- Clint Sewell, Production controller in PCC, was working GC-2 pads
- Casey Williams, EOC operator, monitors leak detection system
- Shawn Croghan, GC2- Area Mgr
- Gary Crawford, CIC TL
- Hal Kruschke, CUI Specialist
- Kip Sprague, Integrity analyst
- Pat Ramsey, GC2 Pad operator, was with Shawn when leak discovered
- Dave Bruchie, Flow Engineer, expert in GPB leak detection system
- Tim Okonek, GC2 Pad Operator
- Ben Hinze, Nalco Production Chemist
- Marty Shearer, Night EOC operator, monitors leak detection system
- Jen Tu, Flow measurement engineer, adjusts leak detection meters
- Randy Denardi, CIC Field inspector
- Andy Fowler, Coordinates Otter flights for aerial surveys
- George Brant, Accuren Project Manager
- Tim Bierl / Andy Spano, Anchorage Corrosion Engineer
- Jim McNew, Night Shift CIC Field Inspector
- Ann Cook, EOC operator, monitors leak detection system

APPENDIX C

SUPPORTING INFORMATION

- C.1 GPB Leak Detection Monitoring and Response Procedure
- C.2 GPB Leak Detection System Overview
- C.3 Commitment to Corrosion Monitoring: 2000 Work Plan
- C.4 Appendix 3. GPB Corrosion Management System



GPB Leak Detection Monitoring and Response Procedure

Authority:	GPB PROD OPT TL	Custodian:	GPB EOC Specialists
Scope:	GPB	Document Administrator:	BPXA HSE Web Specialist
Issue Date:	June 12, 2003	Issuing Dept:	Operations
Revision Date:	January 30, 2006	Control Tier:	3 - GPB
Next Review Date:	January 30, 2009		

1.0 Purpose/Scope

The purpose of this procedure is to establish appropriate procedures and documentation to maintain the Leak Detection System integrity and to document responsibilities and constraints on persons maintaining the leak detection system integrity.

2.0 Definitions

Not applicable.

3.0 General Requirements

The Leak Detection System Administrator (LDSA) will be the main contact as defined in the following procedures. Currently, this position is maintained by the Flow Measurement Engineer (659-5064, pgr 659-5100, 2202; alternately, contact the Controls Engineer at 659-5323, pgr 659-5100, 1204).

4.0 Key Responsibilities

Not applicable.

5.0 Procedure

5.1 Specific Action

To maintain leak detection system integrity -

- Allocation meters must be proven at least quarterly at all endpoints, as per existing procedures. CMMS Preventative Maintenance (PM) records shall be documented, including any required recalibration information.
- As found and as left information is desirable but not required. Document any significant instrument drift in the instrument loop folder. This may be used to optimize PM schedules.

The leak detection system should be tested as agreed by the Alaska Department of Environmental Commission and BP. The LDSA will coordinate testing. Tests results will be reviewed and recorded in document control files similar to safety critical ESD testing. The LDSA will be responsible for training operators and maintenance technicians on the Leak Detection System.

Either functional or Software testing shall be performed:

- Annually and after hardware or software changes that may affect system reliability.
- When system integrity is suspected to be compromised.

Functional tests are preferred when:

- Significant software modifications are made.
- A simulated pipeline leak can be made utilizing equipment and personnel available for related work, such as pigging the pipeline.

Control Tier: 3 - GPB

Document Number: UPS-US-AK-GPB-PCC-HSE-DOC-00001-3

Revision Date: 01/30/2006

Print Date: 3/5/2006

PAPER COPIES ARE UNCONTROLLED. THIS COPY VALID ONLY AT THE TIME OF PRINTING. THE CONTROLLED VERSION OF THIS DOCUMENT CAN BE FOUND AT <http://alaska.bpweb.bp.com/vems/>

- Inventory or de-inventory of either pipeline will occur.
- A functional test leak has not been performed within 3 years.
- The weather allows.

Any defeated alarms shall be reported to the LDSA in a timely manner and will be discussed at shift change in the daily meeting until fixed per existing safety defeat log procedure. The OTL is the responsible for oversight of this reporting process.

5.2 Tuning Constant or Software Change Documentation

All changes to the leak detection software or tuning constants will be controlled by the LDSA. All software changes will be implemented using the Work Order (WO) and Management of Change (MOC) procedure. Software configuration changes to the Data Acquisition System or EFA System will require an MOC authorized by the LDSA.

Changes to flow, pressure, temperature, metering signal instrument ranges, and filter time constants can affect system sensitivity and operation. These changes are reported to the Flow Measurement Engineer (FME) per existing work order system. FME is responsible to consider the implications of these changes.

All tuning changes that affect detection sensitivity and software access:

- Are password protected. The LDSA, FME, and Instrument Engineer (IE) are authorized with the password.
- Shall be recorded in the EFA collect.inf file. A monthly hard copy will reside in the LDSA's office as an archive.
- Will be reported to the on shift operator in the Eastern Offtake Center (EOC).

5.3 Documentation

Leak Detection System alarm events will be automatically recorded in the Setcim log files. Additionally, EOC will document all hi/hi and lo/lo alarms in Leak Detection Alarm Event Log.

Tuning changes will be recorded in the EFA collect.inf file. A monthly hard copy will reside in the LDSA's office as an archive documented. Responsibility - LDSA

Software or functional tests results are stored in document control. A minimum of the 2 most current test results will be stored. Trend data, alarm history, DCS printer data may be stored with the test results when indicated. Responsibility - LDSA

Backup files of PLC software, leak detection software, data files, system history, and other system design documents shall be maintained in the Automation Shop, plant P&ID's, on password protected disk files, or with other controlled and uncontrolled documents. Responsibility - LDSA

Ensuring training documentation is available for operating personnel. Responsibility - Production Optimization TL

Alarm interpretation shall be made using the "Response to Leak Detection Alarms" methodology below. Responsibility - EOC Specialist/LPC Board

RESPONSE TO LEAK DETECTION ALARMS

PURPOSE:

This procedure guides the Eastern Offtake Center (EOC) and Lisburne Control Center operators through the steps required when there is a leak detection alarm. These steps will help determine the cause of the alarm and the appropriate action.

Note: Mass Pack leak detection calculations are performed by a proprietary patented algorithm (PPA) system. The "EFA" leak detection system acquires total inlet and outlet crude flow from the meters at GC1, GC2, FS1, FS2, FS3, COTU, and TAPS PS-1 every 1-2 seconds. The Mass Pack system updates every minute. The control system will generate an alarm if the leak tolerance for the patented algorithm is exceeded.

PREREQUISITES / CONDITIONS:

- An alarm on the DCS comes in from the leak detection system.

REFERENCE DOCUMENTS:

- Leak Detection Alarm Event Log.
- GPB's EMS - compliance matrix - for pipeline operations reporting requirements.

HEALTH & SAFETY PRECAUTIONS:

- Refer to the North Slope Environmental Handbook and Alaska Safety Handbook for approved environmental management procedures and practices.
- Refer to Alaska Safety Handbook for approved PPE requirements for cold weather operations while inspecting the pipeline.

- | | |
|--|---|
| <ol style="list-style-type: none"> 1. VERIFY the alarm | <ol style="list-style-type: none"> 1.1 Check the alarm on the DCS display. 1.2 Go to the leak detection display to verify the problem and locate the source of the alarm. Determine if an operational upset may be causing the alarm (contact the FS or GC for the segment in alarm). |
| <ol style="list-style-type: none"> 2. For a Low/Low alarm | <ol style="list-style-type: none"> 2.1 The system is in error, log alarm and contact maintenance or the LDSA. Proceed to 5.1. |
| <ol style="list-style-type: none"> 3. For a High/High alarm | <ol style="list-style-type: none"> 3.1 Log Alarm in Leak Detection Alarm Event Log. 3.2 If the alarm is caused by work in the field or a known process upset monitor the system until it returns online. Proceed to 5.1. |

- 3.3 If the adjacent segment is trending low by the same amount, check for segment failure with the following criteria:
- 2.3.1 If the overall segment (seg 2) variation during the past 24 hours is greater than the HH Alarm limit of the segment in question, contact Security to drive the pipeline segment.
- 2.3.2 If the overall segment (seg 2) is stable within the alarm set points of the affected section, use this to monitor system for leaks. There is a maintenance problem. Proceed to 5.1.
3. Verify Pipeline Integrity
- 3.1 If you drive the pipeline and find the integrity to be intact, there is a maintenance problem. Proceed to 5.1.
4. If a LEAK is found
- 4.1 Follow the standard pipeline shutdown or isolation and spill response procedures.
- 4.2 Notify the GPB or GPMA Area Manager or designee immediately.
5. Documentation and Maintenance
- 5.1 If you have identified a maintenance problem and the Leak Detection System is disabled for over 12 hours drive the pipe every 12 hours. When a problem is identified contact the LDSA for system maintenance.
- 5.2 Continue to record any further alarm events in the Leak Detection Alarm Event Log until incident is resolved.

Revision Log

Revision Date	Authority	Reviser	Revision Details
June 12, 2003	Ruth Germany- Pice	Hal Tucker	Initial Version
January 30, 2006	Hal Tucker	EOC Staff	Change log to "Leak Detection Alarm Event Log"; Change notifications if leak is found



GPB Leak Detection System Overview

1. Greater Prudhoe Bay Leak Detection System

The Greater Prudhoe Bay leak detection system covers oil transit lines from the production facilities to pump station 1. This includes two pipelines delivering processed crude oil to Pump Station 1 (PS1) of the Trans Alaska Pipeline System (TAPS):

Pipeline	Facilities
Prudhoe	Flow Station 1 (FS1) Crude Oil Topping Unit (COTU) Flow Station 2 (FS2) Flow Station 3 (FS3) Gathering Center 1 (GC1) Gathering Center 2 (GC2) Skid 50 (SK50)
Lisburne	Lisburne Production Center (LPC)

Figure 1 shows the general layout of the segments. Figure 2 shows all the meters (and their SetCim tags) used in the leak detection system.

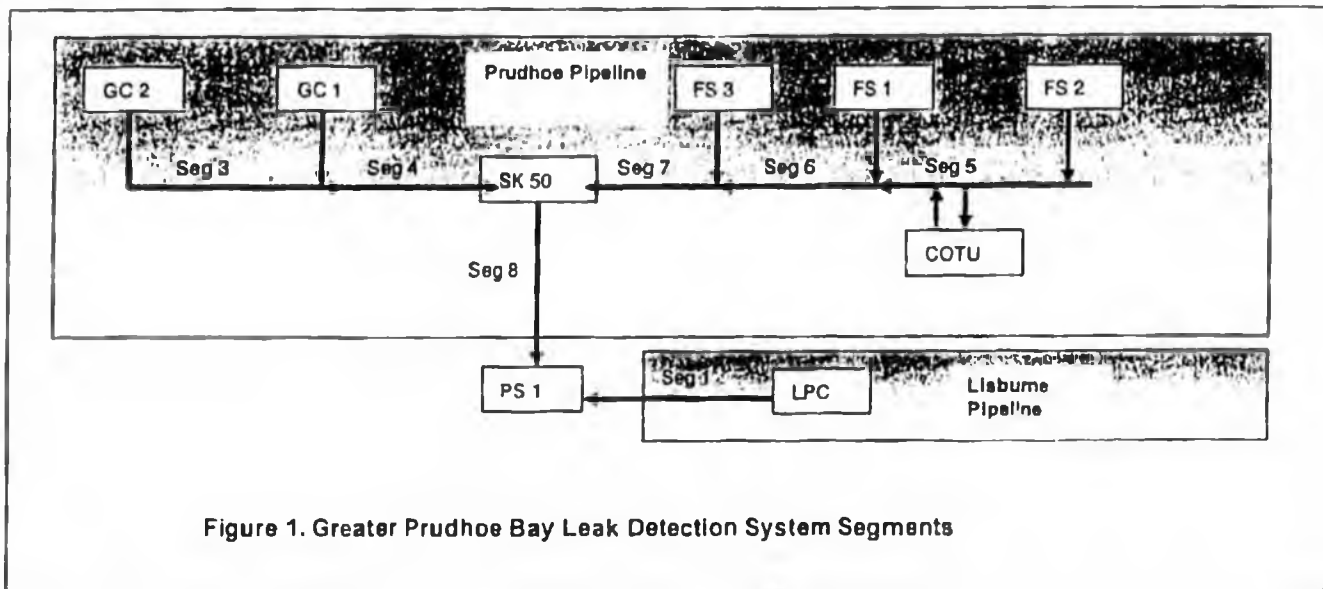

Figure 1. Greater Prudhoe Bay Leak Detection System Segments

GPB Leak Detection System Overview

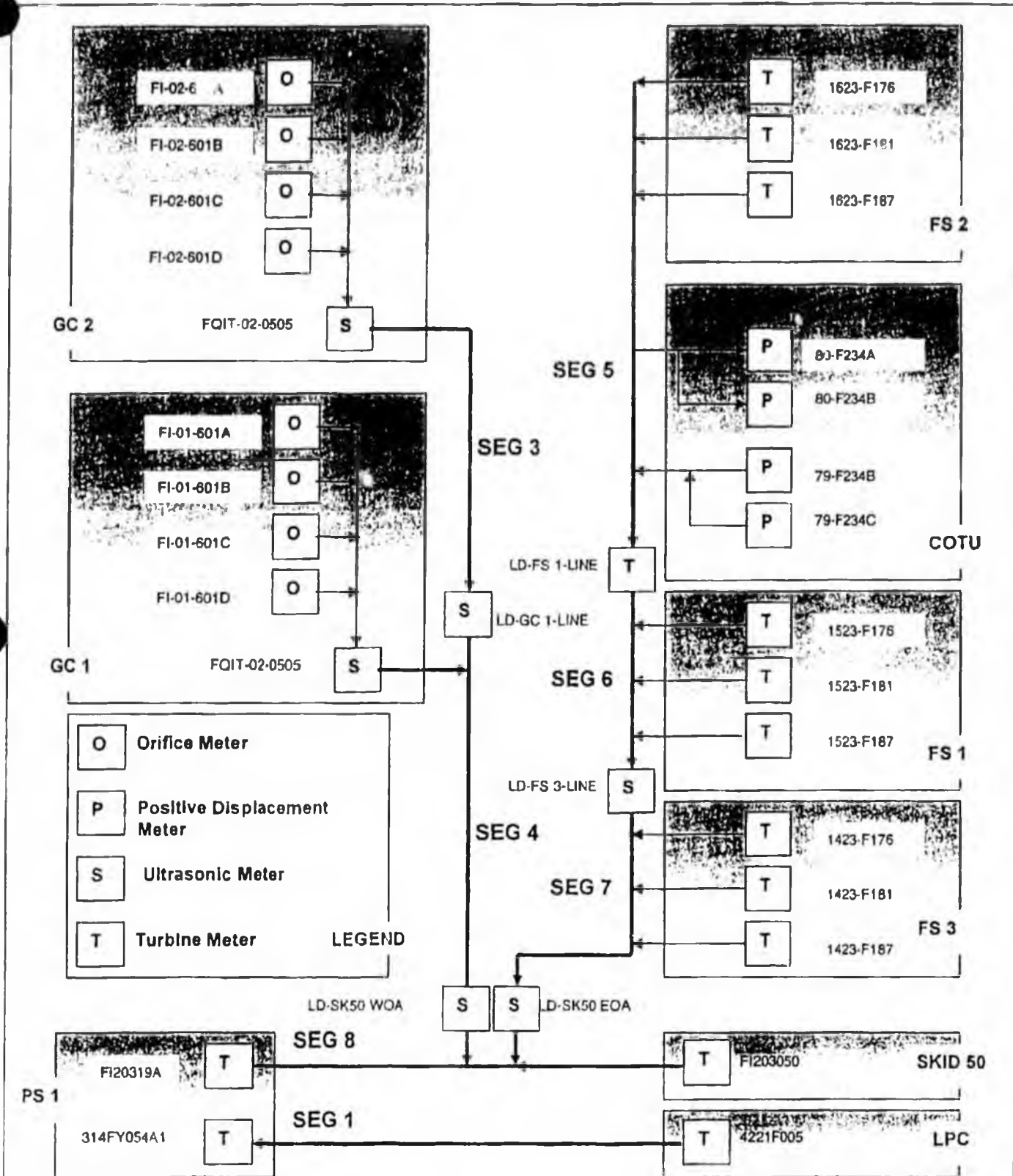

Figure 2 Greater Prudhoe Bay Leak Detection System Meters

GPB Leak Detection System Overview

- Data acquisition system: collects data from field devices, reads and writes data to analysis program.
- Ed Farmer and Associates leak detection software (MassPack)

This system description covers the parts unique to this leak detection system. For detailed information on the various parts and pieces refer to the following vendor documentation.

- EFA LeakNet manual
- Snap Ethernet Brain Programming Guide (Opto22)
- Snap Ethernet Brain Users Guide (Opto22)
- CoBox manuals (Lantronix)

2. SetCim Displays

There are Leak Detection displays on SetCim for EOC and Lisburne. The Lisburne display shows only segment 1 (Lisburne to pump station 1 segment). The EOC display shows all segments (1, and 3 - 8) for the Greater Prudhoe Bay facilities. In both cases the most important information on the screen is the current estimated leak volume for the last minute, hour and day for each segment (MIN ACC, HOURLY ACC, DAILY ACC). An overview graphic has been developed for the PBU Main Oil Line (MOL) that indicates all meter flow rates in BPD and the 1-hour and 24-hour accumulators for each segment.

In addition three segments have been included to assist with analyzing the status of the segments to determine a measurement problem or a potential leak. These segments are 2 - Complete PBU MOL (Combination of segments, 3,4,5,6,7 & 8), 9 - WOA (Combination of segments 3 & 4) and 10 - EOA (Combination of segments 6 & 7).

The following table lists the graphic displays provided on the SetCim Consoles at the two control centers (LPC & EOC).

SetCim Console	Graphic Name
LPC	Leak Detection
EOC	Field Wide Leak Detection EFA Data Input Values Leak Detection PBU Main Oil Line

2.1 Accumulated Leak Volumes

The leak volume can be positive or negative. A positive volume means we are measuring more oil going into the pipe than is coming out of it. This could

GPB Leak Detection System Overview

indicate a potential leak. If the volume is negative, we are measuring more oil coming out of the pipe than is going in. Typically this means there is a system problem. However it is very important to understand if the negative volume becomes too large it can prevent the system from alarming a potential leak event.

The accumulators for each segment average flow rates over the three time spans. For example the hourly accumulator only looks at data from the last hour. This means that one hour after a significant upset the hourly accumulator will be unaffected by the upset; where as the daily accumulator will have residual effects of the upset for up to 24 hours after the event. It should be noted that a process upset could take over 24 hours to clear the pipeline. Accumulators can be reset back to zero once the minute and hourly accumulators have returned to normal and it is determined that there are no leaks or meter failures.

The minute accumulator is too sensitive to flow rate changes etc. to be of much use for leak detection. However the hourly accumulator is more stable and will detect significant leaks (over 3% of normal segment daily flow rate). To meet the State of Alaska regulatory requirement of 1% of daily average flow rate in the specific pipeline segment the system utilizes the 24-hour accumulator. The monthly accumulator is actually a very long time leak accumulator, and is mostly used to monitor system performance. It offers the best tool for fine-tuning the system meter factors.

2.2 Alarms

There are four alarms for each leak accumulator:

- High Alarm and Low Alarm – An early warning that the system may be having a problem. Technical support should be notified so the status of the system can be determined and rectified if required.
- High-High Alarm – Requires immediate operations response. Typically the affected pipeline segment must be driven to verify there is no leak. See the operating procedures.
- Low-Low Alarm – This is not an indication of a leak, however it does mean that the system is far enough out of adjustment that it may not be able to detect a leak. If the problem exists longer than 12 hours the pipeline will need to be driven on a periodic basis. See the operating procedures.

GPB Leak Detection System Overview

2.3 Troubleshooting

There are several things to check for when alarms are initiated that assist with understanding the problem.

- Check the inlet and outlet meters for the segment showing an alarm. If any have suddenly gone to zero, or had larger than normal changes in flow rate check with the facility to determine the current production status
- Check neighboring segments for opposite accumulator trends. For example if segment 3 (GC2 to GC1) is goes into alarm with a large negative 24-hour accumulator change, and at the same time segment 4 (GC1 to Skid 50) is having a similar positive 24-hour accumulator change; the chances are the meter between the two segments is reading high.
- Check segment 2 and the associated segment 9 or 10 according to whether it is an EOA or WOA segment in alarm. Segment 2 covers the complete Prudhoe Bay Pipeline. If it shows a flat trend, for the last 12 to 24 hours, and continues flat during an upset on any other pipe segment. The upset is probably due to meters between segments instead of meters at facility outlets. This works because segment 2 looks only at the facility inlet and outlet meters, and ignores all the segment meters on the pipelines. Segments 9 & 10 provide additional information and may help to determine which segment meter may be causing the problem. They also have increased sensitivity over segment 2 as the segment flow rate is approximately half that of segment 2.
- At GC1 and GC2 we have two sets of meters on the oil outlets. The leak detection system uses ultrasonic flow meters mounted on the oil line outside of the GC. However we also have orifice meters on each production bank (and one to the ullage tank at GC1) that can be added up and compared to the ultrasonic flow meter.

3. Field Devices

3.1 Pressures

The LeakNet system can use pressures to correct for volume changes in long pipelines with high-pressure drops, and in the Pressure Point Analysis (PPA) leak detection algorithm. We have short pipelines with very low pressure drops, and are not currently using the PPA algorithm, so we do not use pressure data at this time.

GPB Leak Detection System Overview

3.2 Flow Measurement

Leak detection is based mainly on flow rates measured throughout the system. In general the system utilizes Turbine, Positive Displacement and Ultrasonic flow meters. In addition the system collects data from the oil bank orifice meters at GC1 and GC2, but these are not the primary leak detection meters. Flows from PS1 are transferred to PBU as 4-20 mA signals. PBU maintains the data acquisition hardware for this data but not the flow meters.

3.3 Turbine Meters

Turbine meter flows are calculated using existing Daniels 2500 or 2233 series flow computers. We plan to upgrade all the 2233 flow computers to 2500 series units in the future. The leak detection system uses actual volume (gross) flow rates. The leak detection system reads flow rate data from Daniels 2500 series flow computers over the network using a Lantronix terminal server, typically a CoBox. These are maintained by automation. The inputs from the 2233 units are 4-20 mA signals to an Opto22 data acquisition system.

The Oil Production Meters at FS 1,2 & 3 all have a master meter that can be used to prove the meters and compensate for meter factor drift. The FS 1 Line and the LPC Oil Production Meter are balanced against meters that are proved. The Leak Detection System Meter Factors for these meters are adjusted to ensure a balance to the other inlet or outlet meters rather than proving them against a dedicated master meter.

3.4 Ultrasonic Flow Meters

In general strap-on non-intrusive ultrasonic flow meters are installed at pipe segment junctions, especially if they are outside. Meters are also installed the main oil production lines from both GC1 and GC2 as alternates to the existing orifice meters. They have the advantage of being downstream of all process equipment that can modify the volume or pressure and temperature of the oil exported to the MOL.

The meters are 4 channel (8 transducer) Controlotron 1010 special units. The units are sold for custody transfer quality meters when mated to factory built meter runs. The meter will average the flow measured by each of the four channels.

The analog flow rate output from these meters is transmitted to an Opto22 Ethernet I/O unit. In addition the Controlotron serial port is wired to the network via a Lantronix terminal server for access to diagnostics on a PC.

Orifice Flow Meters

Orifice meters are installed on the oil banks (A to D) at GC1 and GC2 for

GPB Leak Detection System Overview

Production Allocation. They offer an alternative to the ultrasonic flow meters on the oil lines from the facilities. However they are upstream of the bank 3rd stage separator level control valve, the oil coolers and the water cut analyzer. For these reasons they require fairly extensive corrections to calculate the actual oil volume at pipeline conditions rather than at standard base conditions.

The orifice meter flow is calculated using a Daniels 2500 flow computer. The leak detection system reads flow data from Daniels 2500 series flow computers over the network using a Lantronix terminal server, typically a CoBox. These are used by flow measurement and maintained by automation.

4. Data Acquisition System

4.1 General Overview

The data acquisition system collects field data from transmitters and flow computers over the process network, and transmits it to the leak analysis programs (MassPack and PPA). All data input and output from the leak analysis programs is made available for display through SetCim. Figure 3 shows a block diagram of the system. The data acquisition system includes field I/O devices (Opto22 Ethernet I/O, Lantronix/Schneider ModBus and serial terminal servers), and programs running on the LeakNet Computer located in the EOA Automation Shop.

The data acquisition system is built around a shared memory organized as a set of ModBus registers and the various programs that read and write data to this memory. The data acquisition system has five sections:

- A ModBus server to let SetCim read and write the shared memory
- Analog data collection (using Opto22 Ethernet I/O)
- Interface to Daniels flow computers
- Interface to Allen Bradley PLC at skid 50
- Interface to and from the EFA leak detection programs

A separate program running on the LeakNet computer controls each section of the data acquisition systems. In most cases each program has a initialization configuration file (*.Inf) that sets important operating parameters.

GPB Leak Detection System Overview

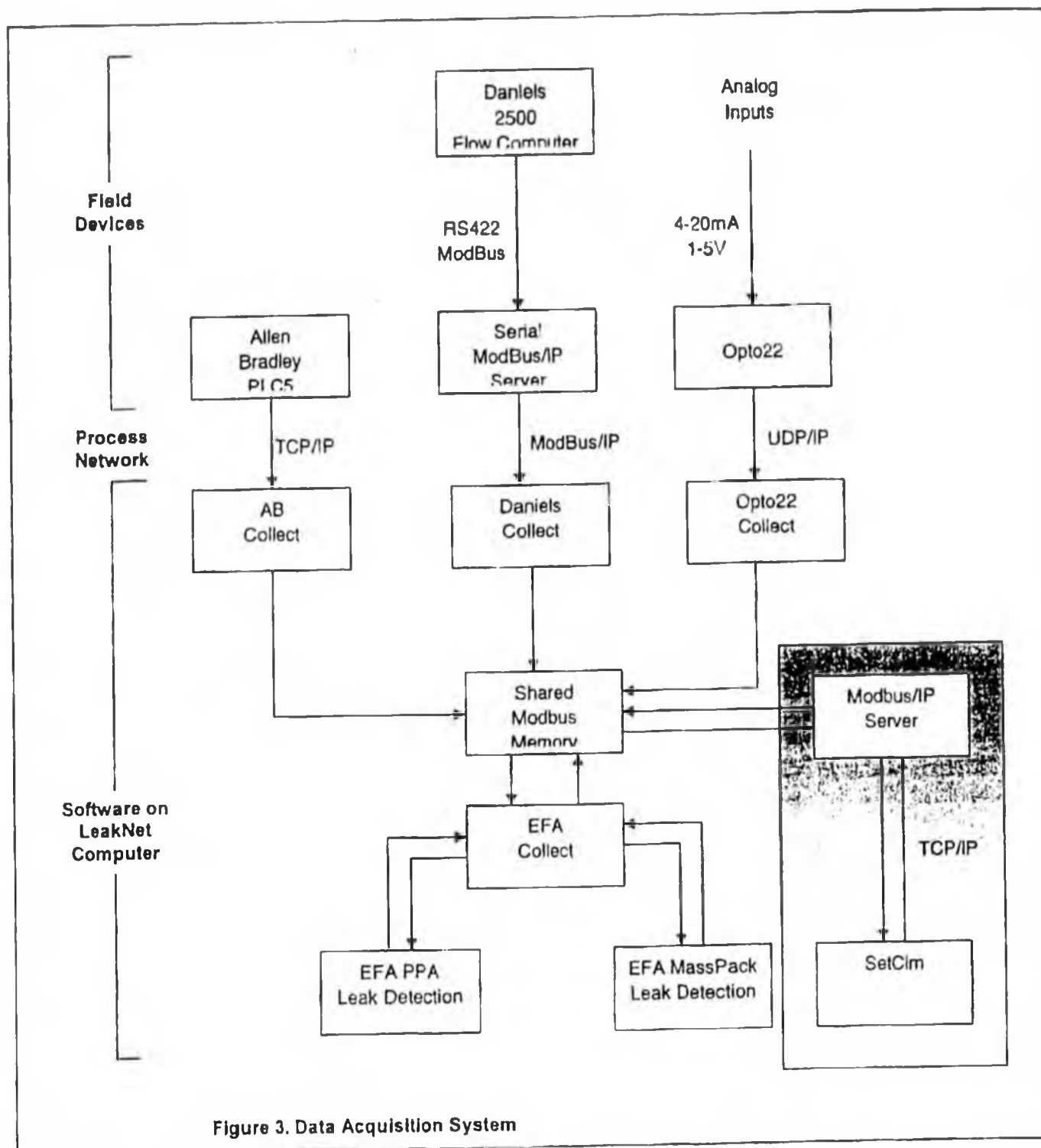

Figure 3. Data Acquisition System

GPB Leak Detection System Overview

4.2 Configuration Initialization – (.Inf Files)

Each data acquisition program has at least one configuration *.Inf file that it reads at startup. These files all have a similar format. Annotation and comments can be added to the file by placing a semicolon (“;”) at the start of the line of code; the system will ignore that line of code. Each section of the file starts with a label enclosed in square brackets ([S3 GC2]). In most cases each section of the file describes how a single set of data acquisition registers are read or written. The parameters are defined on separate lines, each line has a parameter name and value separated by =. Some common parameters found in the .Inf files are:

- Device Type – there are only a few different supported device types. Do not change this value.
- IP Address – IP address of a field I/O device
- Number Of Registers – the number of ModBus registers transferred in the data acquisition database. Remember each floating-point value needs two registers.
- Packet Receive Counter – a register that counts good packets, each section of an .Inf file needs a separate memory location.
- Packet Receive Flag – Set when any good packets are received, each section of an .Inf file needs a separate memory location.

4.3 ModBus Server

The shared memory in the LeakNet computer is available on the process network using the ModBus/IP protocol (IP address 136.226.51.201 port 502 device 1). The MBServe program running on the LeakNet computer manages access to this memory. The ModBus interface is primarily used by SetCim to retrieve data for display. Any other program that can communicate using the ModBus/IP protocol can also use it. This program has no configuration file. Register addresses are set in the other .Inf files.

4.4 Analog Inputs

Analog signals from pressure transmitters, Controlotron ultrasonic flow meters and Daniels 2233 flow computers are transmitted to the system via Opto22 Ethernet I/O devices. The analog inputs are scaled to engineering units (typically bb/day and psig) at the Opto22, and broadcast to the LeakNet computer where they are saved unchanged in shared memory by the Opto22 Collect program. All the analog inputs in shared memory used by the leak detection system are displayed on the EFA Inputs screen on SetCim, which is accessed through the Leak Detection screen. Use this screen to troubleshoot any inputs to the leak detection system.

GPB Leak Detection System Overview

4.5 Opto22 System

4.5.1 Opto22 Ethernet I/O

The Opto22 Ethernet I/O units accept analog signals, convert them to engineering units, and broadcast them to the LeakNet computer once a second. The Opto22 units consist of a power supply, the local processor (B3000-Ethernet Brain [®]) and various I/O modules. The brain and I/O modules are plugged into a base plate. They can be configured using a web browser from a computer connected to the process network.

The Opto22 is fitted with AIMA-2i modules for the 4-20 mA signals. These are two channel isolated ± 20 mA input modules. Both channels are isolated from each other and the brain's ground. These modules use an internal 250 Ω current sensing resistor. They do not supply loop power. See figure 4 for typical wiring.

The Opto22 is fitted with AIV-2i modules for the 1-5 Volt signals. These are two channel isolated ± 5 volt input modules. Both channels are isolated from each other and the brain's ground. These modules do not supply loop power. See figure 5 for typical wiring diagrams.

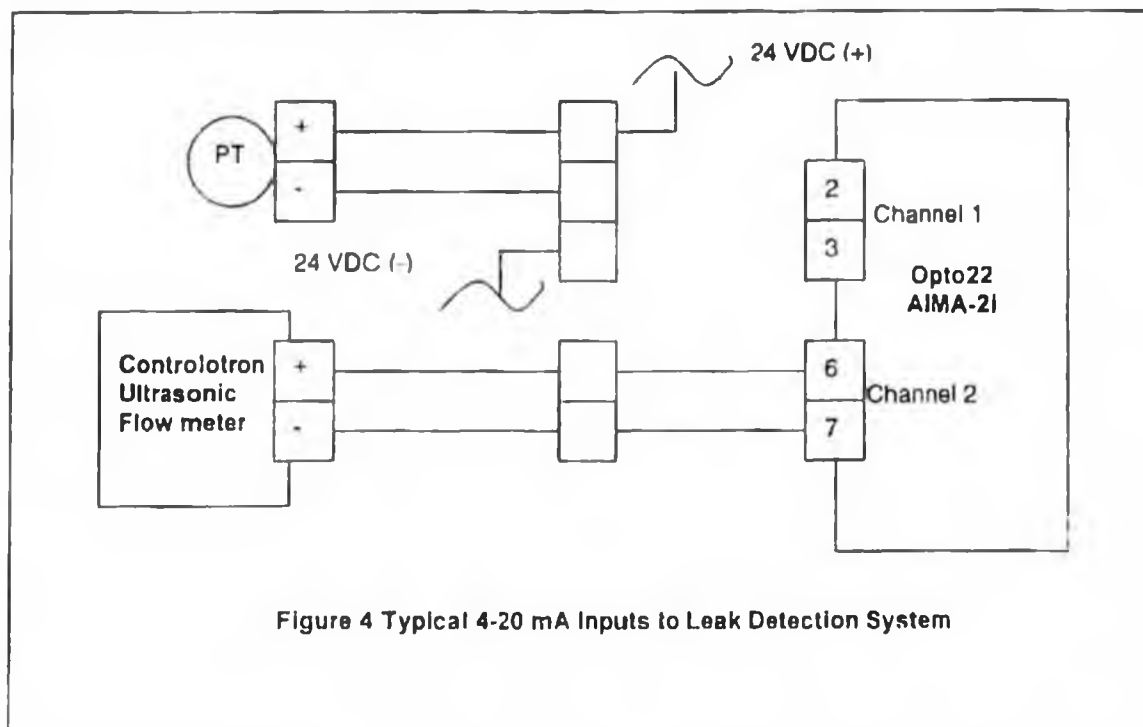
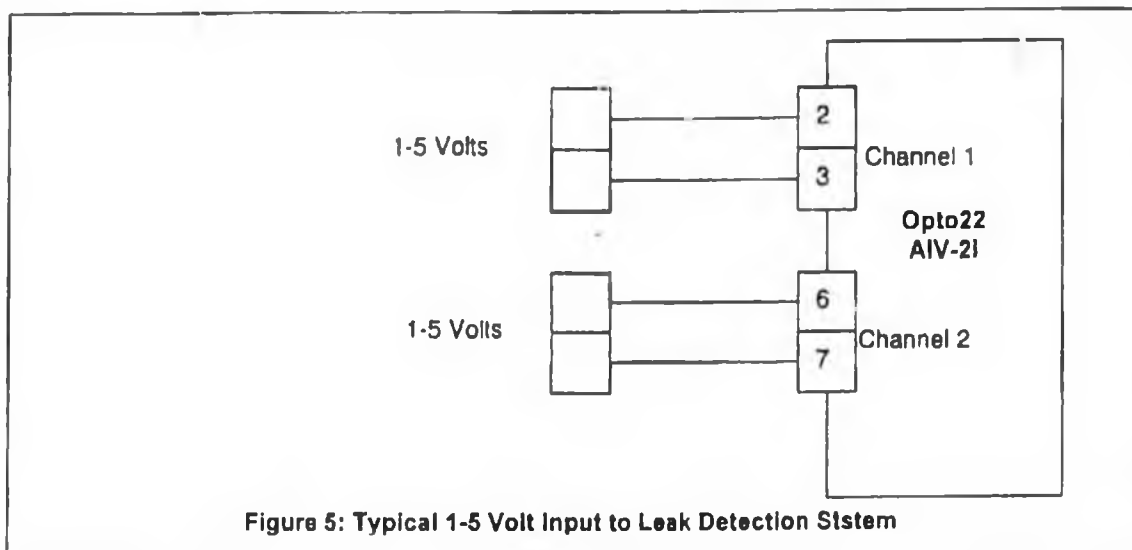

Figure 4 Typical 4-20 mA Inputs to Leak Detection System

GPB Leak Detection System Overview



To communicate with an Opto22 access the Automation Internet Explorer on a Process Network Console and enter <http://Name> (Taken from table below) and follow the instructions given. The menu items Analog Bank Read and Configuration provide all the information we need to know.

Name	IP Address	Point #	Tag #
FS1LD	136.226.80.100	0	1523-F176 (160);
		1	1523-F181 (161)
		4	1523-F187 (162)
		5	FS 2 @ FS 1 Line
FS2LD	10.0.20.100	0	1623-F176 (260)
		1	1623-F181 (261)
		4	1623-F187 (262)
		8	Pressure
FS3LD	136.226.235.100	0	1423-F176 (360)
		1	1423-F181 (361)
		4	1423-F187 (362)
		5	FS 1 @ FS 3 Line
COTULD	136.226.51.100	0	80-F234A (530)
		1	80-F243B (531)
		4	79-F173B (533)
		5	79-F173C (534)
LPCLD	136.226.43.100	0	4221-F005 (1001)
		1	LPC Pressure
PS1LD	136.226.123.100	0	PS 1 LPC Press
		1	314FY054A1
		4	PS 1 PBU Press
???	136.226.123.103	0	SK50-EOA
		1	SK50-WOA

GPB Leak Detection System Overview

Analog Bank Read – displays of all the Opto22 analog inputs organized as 4 values per module. As the Leak Detection System only utilizes 2 channels isolated current input per module valid results will be restricted to points 0 & 1 (Module 1), 4 & 5 (Module 2) and 8 & 9 (Module 3). 3 modules is the maximum fit at any location. Typically these values should be changing and match the expected process variable. Full verification can be performed by comparing these results with the values on the EFA Inputs screen on SetCim.

Configuration – pulls up another menu. I/O Points and Streaming are the two menu items to utilize here.

I/O Points – displays all the I/O points and enables any point to be configured. Typically the Point Type is set to 4–20 mA. All other settings are set to 0 or disabled. The Point Gain is typically set to 1.0. The Point Upper Scaled Units are set to the full-scale flow rate in BBL/Day (BPD) or PSIG for pressure. The Point Lower Scaled Units is typically set to 0.

Before a flow meter is taken out of service, set the Point Gain to 0.0000001. Not all Opto22 units accept a 0 Point Gain setting. This prevents the leak detection system from getting a less than zero input. This will keep the Leak Detection System operational while a meter is being serviced or repaired.

Streaming – enables the Opto22 to be configured to broadcast a set of registers to a set of computers on a different segment of the network. This feature is utilized to broadcast all the analog values to the LeakNet computer's network segment.

The normal configuration is:

- Enable Streaming – Enabled
- Stream Interval (msec) – 1000
- Address of Data to Stream – 0xF0600000
- Size of Data to stream – 140
- Streaming IP Port # – 5002
- Streaming Target #1 – 136.226.51.255
- All other streaming addresses are 0.0.0.0
- IO Mirror – Disabled
-

A print out of all I/O Point configuration pages and the Streaming page is to be maintained by the Leak Detection System Administrator.

Automation is responsible for maintaining the Opto22 hardware and setting the TCP/IP address, and UDP data streaming configuration. The L.D.S.A is responsible for the individual channel configurations (upper and lower range limits).

GPB Leak Detection System Overview

4.5.2 Opto22 Collect.inf

The OPTOCOL.exe program collects data broadcast from the Opto22 Ethernet I/O devices and stores it in the LeakNet computer's shared memory. The Opto22Collect.inf provides the configuration for the exe file at startup.

Both of these files are stored in C:\Program Files\Opto22 Collect\ folder on the EFA PC.

A typical section from this file looks like:

```
[COTU]
Device Type           = SNAP-P3000-ENET
IP Address            = 136.226.1.100
Analog Points         = 0,1,4,5
Analog Holding Registers = 40020,40022,40024,40026
Packet Receive Counter = 40902
Packet Receive Flag   = 10002
```

The parameters can be used as follows:

- Analog Points – select values from the list sent by the Opto22. The numbers match the point number shown on the Opto22 Bar.k Read web page.
- Analog Holding Registers – a list of data acquisition system registers, one entry for each point read. Each value fills a pair of data acquisition system registers, but only the first one is listed. These register pairs do not need to be in any particular order. Normally these registers are in the 40xxx range.

4.6 Daniels 2500 Series Flow Computers

4.6.1 General

The Daniels 2500 series flow computer can make internal data available over a serial port using the ModBus protocol. Either a Schneider or Lantronix ModBus/IP terminal server is used to connect to the Daniels ModBus over the process network. The Daniels Collect program on the LeakNet computer polls the flow computer for data every 1 or 2 seconds, and stores this data in the LeakNet computers shared memory for use by SetCim and the leak detection software.

The Daniels flow computer is programmed by the Flow Measurement

GPB Leak Detection System Overview

engineer, and wired per the appropriate loop drawings. The leak detection system reads gross flow values from the flow computer over the ModBus serial port.

4.6.2 Schneider/Lantronix ModBus/IP Terminal Server

The automation shop maintains the Schneider and Lantronix ModBus/IP servers connected to Daniels flow computers. To functional test the system verify the process values reported by SetCim match the source data in the 2500 flow computer. A simple ping test will verify the terminal server's IP address and that it is functional. The status LEDs on the Schneider block also provides a means of checking the operation of the system.

- If both LED's below the unused plug port blink every 1 or two seconds it is being polled by the leak detection system and responding. If this happens and you are not getting flows, check the EFA Data Acquisition Software.
- If only one LED flashes, it's being polled and is not responding; check the flow computer.
- If neither flashes it's not getting any requests. This means the EFA PC cannot see it over the network. Check the Schneider block, the EFA Data Acquisition Software and the Network. This may need Automation assistance.

The ModBus terminal server IP addresses are:

SetCim Tag	IP Address	Description
FI01601A	10.1.10.100	GC1 oil bank flow computer
FI01601B		
FI01601C		
FI01601D		
FI02601A	10.1.20.100	GC2 oil bank flow computer
FI02601B		
FI02601C		
FI02601D		

A more up to date list of IP addresses can be found on the EFA Inputs screen on SetCim.

GPB Leak Detection System Overview

4.6.3 Daniels Collect.inf

The DANCOL.exe program collects from the 2500 Flow Computer and stores it in the LeakNet computer's shared memory. The Daniels Collect.inf provides the configuration for the exe file at startup.

Both of these files are stored in C:\Program Files\Daniels Collect\ folder on the EFA PC.

All data transferred is floating point, the computer manipulates the data into two short integer registers as follows:

$$T = \text{INT}(X * 1000)$$

$$R1 = \text{MOD}(T, 65535)$$

$$R2 = \text{INT}(T / 65535)$$

where:

- X- the value in Daniels flow computer.
- T- temporary value
- R1 - first ModBus register
- R2 - second ModBus register

This effectively gives us a floating-point number with a value up to 2 million with resolution to 0.001. Note: the factor used to split the number into two words is 65535, not 65536. You cannot just split a 32-bit number into upper and lower 16 bit words; you have to do the math. The Daniels driver expects its values to be in this format.

This is a typical section of the file:

```
[GC1]
Device Type = Daniels
Device ID = 1
IP Address = 10.1.10.100
Starting Input Register = 43002
Starting Output Register = 40440
Number Of Registers = 8
Packet Receive Counter = 40944
Packet Receive Flag = 10044
```

The parameters can be used as follows:

- Device ID - should match the ModBus address of the flow computer.

GPB Leak Detection System Overview

Normally this is set to 1.

- Starting Input Register – the first ModBus register read from the field device.
- Starting Output Register – the first register written in the data acquisition system. Normally a register in the 40xxx range is used.

4.7 Allen Bradley PLC

4.7.2 General

An Allen Bradley PLC at Skid50 provides the flow rate data for the PBU Production to PS 1 and the NGL blended into the PBU MOL at Skid 50. The PLC is already connected to the process network, and the Automation engineers handle the PLC configuration.

4.7.3 Allen Bradley Collect.inf

The ABCOL.exe program collects from the Allen Bradley PLC 5 at Skid 50 and stores it in the LeakNet computer's shared memory. The Allen Bradley Collect.inf provides the configuration for the exe file at startup.

Both of these files are stored in C:\Program Files\AB Collect\ folder on the EFA PC.

Each section reads one group of registers from a single PLC. The PLC is selected by its IP address. The Leak Detection System addresses only one PLC 5 with 12 floating-point variables being transferred (24 registers), which is more than required. This is more efficient in time than having to perform 2 read requests. This is the only entry in the Allen Bradley PLC .Inf file.

[NGL]

Device Type = Allen Bradley PLC5

IP Address = 136.226.123.101

Timeout Connect = 500

Timeout Reply = 500

Starting Input Register = F8:15

Starting Output Register = 40280

Number Of Registers = 24

Packet Receive Counter = 40928

Packet Receive Flag = 10028

The parameters can be used as follows:

GPB Leak Detection System Overview

- Starting Input Register – the first register read from the PLC specified using AB notation.
- Starting Output Register – the first register written to in the data acquisition system. This register is normally in the 40xxx range.

4.8 EFA Collect

4.8.1 General

Within the EFA System there are two different Leak Detection Systems; MassPack (MP) and Pressure Point Analysis (PPA). The MP is the primary system currently being utilized, however the PPA system has been defined and is included in the *.inf files and displays. The pipelines covered by this system are not long enough to gain any benefit from including pressure in the leak detection analysis. The system also uses gross volume flow rates rather than standardized net volumes.

The EFACOL.exe program collects flow rate and pressure data from the Shared ModBus Memory and writes input files (osin.dat and ppain.dat) used by the MP and PPA leak detection programs. It also reads the output files (.npout.dat, ppaout.dat and stat.out) from these programs and writes the results to the LeakNet shared memory. The EFACOL.exe program also groups meters into pipe segments, converts the flow rate data to bbl/min, applies meter factors, and groups physical meters into logical meters (e.g. Flow Station Oil Production Meters).

The pipelines are split into segments and the EFACOL.exe program collects meter data for each pipe segment. Each pipe segment can have up to 12 meters and 2 pressures (one inlet, one outlet pressure). This program assigns each meter to the pipe segments (MPA index, MP segment). Two *.inf files are provided for the EFACOL.exe file to read at startup. (EFA Collect.inf and EFA File IO.inf)

4.8.2 EFA Collect.inf

The EFACOL.exe program collects data from the Shared ModBus Memory and stores it in the LeakNet Computer's Shared Memory as well as writing data input files for the MP and PPA Leak Detection Systems. The EFA Collect.inf file controls the configuration of the meter and pressure data used by the EFACOL.exe program at startup

Both the exe and inf file are stored in C:\Program Files\EFA Collect\ folder on

GPB Leak Detection System Overview

the EFA PC.

Each section in the file can define a flow and a pressure. Both of these can be used as part of a MassPack pipe segment or PPA points. So each group can define up to 4 different EFA parameters:

- A flow in a MassPack pipe segment
- The end of line pressure for a MassPack pipe segment
- A PPA pressure point
- A flow for a PPA point
-

A flow can be into or out of a pipe segment from a single location. It can be the sum of several parallel meters. At the flow stations the three oil shipping meters are combined into a single flow.

If a meter or pressure is used in more than one MassPack segment, it will have to be redefined in each section. A good example of this is the ultrasonic flow meters on the main oil transit line. They are outlets from the upstream segment, and inlets to the downstream segment, and will appear in at least two segments in the .Inf file.

Not all the parameters need be used in each section of the .Inf file. The following example shows all possible parameters:

```
[Lisburne]
Device Type = Opto22 SNAP-B3000-ENET
Flow PPA Index = 3
Flow MPA Index = 3
Flow MP Segment = 1
Flow Scale Factors = .00069444
Flow Registers = 40600
Pressure Registers = 40602
Pressure Scale Factors = 1
Pressure PPA Index = 1
Pressure MPA Index = 1
Good Data Counter = 40846
Bad Data Counter = 40746
Packet Receive Flag = 10060
```

The parameters can be used as follows:

- Flow PPA Index – sets PPA index for this flow. If this flow is used in multiple pipe segments, you only need to define the PPA index in one of its groups. Valid PPA indexes are 1–50.
- Flow MPA Index – sets the index within a MassPack record for the flow. Valid MPA indexes are 3–12.
- Flow MP Segment – sets the pipe segment for this group's

GPB Leak Detection System Overview

- flow and pressure. Valid segment numbers are 1-10.
- Flow Scale Factors – scaling factors to convert input flow values into bbl/minute rates. Typically we read flows in bbl/day, so the scaling factor is 0.00069444. This equates to a meter factor of 1.0000. By adjusting this scaling factor away from 0.00069444 we can apply a meter correction factor to trim the segment balance. The system needs one scaling factor per flow register. See section 4.8.3 Online Parameter Changes for details.
 - Flow Registers – list of registers containing flows to be combined into this logical flow. A good example is the 3 parallel turbine meters at a flow station. By listing the input registers for all three meters here, they are added into a single logical flow. Field data is stored in the 40xxx series registers.
 - Pressure Registers – the input register containing the pressure. Should be a single register. Field data is stored in the 40xxx series registers.
 - Pressure Scale Factors – always 1 so far.
 - Pressure PPA Index – sets PPA Index for this pressure. If this pressure is used in multiple pipe segments, the PPA Index only needs to be defined in one of its groups. Valid PPA indexes are 1-50.
 - Pressure MPA Index – sets Index within a MassPack record. Should be 1 for inlet pressure, 2 for outlet pressure. The pressure's MP segment number is set by the Flow MP Segment parameter.
 - Good Data Counter – used for data validity check, registers in the 408xx range are used for this purpose.
 - Bad Data Counter – used for data validity check, registers in the 407xx range are used for this purpose.
 - Packet Receive Flag – points to the receive flag for the data being used here. This flag is defined in one of the other .Inf files that read data from field devices. Registers in the 100xx range are used for this purpose.

4.8.3 Online Parameter Changes

Many of the parameters in EFA Collect.Inf can be tuned on line. To bring up the tuning display click the "Config" button on the EFA Collect window on the LeakNet computer display. You will get a scrolling list of meters (listed by the names in EFA Collect.Inf). Selecting any meter you get a dialog box showing parameters you can change. The only parameter you should be changing is the "Scale Factor". As described above this factor combines a unit conversion (normally from bbl/day to bbl/min) and meter factor. It is usually close to 0.00069444, typically between 0.00066 and 0.00073. Sometimes it is

GPB Leak Detection System Overview

displayed in scientific notation as 6.9444E-04 instead of 0.00069444.

4.8.4 EFA File IO.inf

The EFACOL.exe program writes two files, osin.dat and ppain.dat the LeakNet program reads. It also reads data from three files the LeakNet program writes: mpout.dat, ppaout.dat and statout.dat. All this data is stored in the ModBus registers. The EFACOL.exe program uses the EFA File IO.inf file to determine the store location for the data in each file. This file only needs to be updated if the number of meters per segment, the number of segments or the number of PPA points is modified. The following details the current file:

[EFA Software Setup]

Number of PPA points = 50

Number of MP segments = 10

Meters per segment = 14

[EFA File IO]

OSin Base Register = 41000

PPAin Base Register = 42000

PPAout Base Register = 44000

MPout Base Register = 45000

STATout Base Register = 47000

The EFA Software Setup parameters set the size of internal arrays. The EFA File IO parameters tell the program where to start storing data for each file in the local shared memory. Any time this file changes, SetCim must be modified to match.

5. EFA Leak Detection Programs, MassPack and PPA

The EFA leak detection programs perform the MassPack and Pressure Point Analysis leak detection algorithms. The MassPack system is the only live leak detection system at the moment. The system reads its configuration from C:\PPA\meter.dat on start-up (saved as DEFAULT.MSP in the EFA Editor). There should be no need to make changes to this configuration file unless we add more meters or pipe segments to the system.

If any changes are made to the EFA leak detection programs using the Editor program, they should be saved to a new .msp file, on exiting the editor program. The name of this file should be added to the C:\PPA\readme.txt file, along with a short description of any changes made, the date and who made

GPB Leak Detection System Overview

the changes.

As meter factors are now made outside the EFA Leak Detection System there should be very few if any changes made to the EFA System.

6. Maintenance Procedures

As the system has now been successfully configured maintenance is restricted to two basic functions. Restarting the EFA LeakNet Computer and updating meter factors for the segment meters.

6.1 LeakNet Computer Restart

The following procedure should be followed to get the leak detection system operating successfully:

- Login – Log into the computer as Administrator, this starts the main EFA leak detection program.
- Verify the "Master Display" for PPA and MASSPACK appears, if not, try rebooting.
- Start the ModBus server MBServe. Either use the "Modbus Server" entry on the Start-Programs menu or go to C:\Program Files\Modbus Server and double click MBServer.exe. You can verify this program is running by checking that recent data was received on any leak detection tag displayed on the EOC Leak Detection page. You should do this as part of starting the other programs below.
- Start Opto22 Collect. Either use the "Opto22 Collect" entry in the Start-Programs menu or go to C:\Program Files\Opto22 Collect and double click OPTOCOL.exe. When this program is running a small window labeled "Opto22 Collect" listing IP addresses and message lengths as they are received will appear. If no messages are being received, check the streaming configuration of any Opto22 device sending data to this system (see the Analog Inputs section). You can check that any tag listed on the EOC SetCim Leak Detection Inputs page coming from an Opto22 is showing recent data too.
- Start Daniels Collect. Either use the "Daniels Collect" entry in the Start-Programs menu or go to C:\Program Files\Daniels Collect and double click DANCOL.exe. Once this program is started you should see a Daniels Collect window on the screen. It only logs errors, so it may be empty. You can check that it is running by looking for recent data for any Daniels tag on the EOC SetCim Leak Detection Inputs page.

GPB Leak Detection System Overview

- Start Allen Bradley Collect. Either use the "Allen Bradley Collect" entry in the Start-Programs menu or go to C:\Program Files\AB Collect and double click on ABCOL.exe. When this program is running you a small window labeled "AB Collect" showing Allen Bradley PLC registers, values, and corresponding shared memory registers being read will appear. The values should change every second or so. You can also verify recent updates to any Allen Bradley tag on the EOC SetCim Leak Detection Inputs page.
- Start EFA Collect. Either use the "EFA Collect" entry in the Start-Programs menu or go to C:\Program Files\EFA Collect and double click on EFACOL.exe". When this program is running a small window labeled "EFA Collect" will appear. About every 6 seconds it should post a message about writing a PPA file. Once a minute a message about an OS file should appear.
- Verify VNC has started (a small icon at the lower right on the task bar). If it has not contact automation to have it restarted. VNC is not critical for detecting leaks. It allows remote monitoring and meter factor changes.

6.2 Changing Meter Factors

Before any meter factor is changed, all meters involved in the pipe segment must be checked for proper operation, you should check that there are no un-metered flows into or out of the segment, and there is no leak (the line must have been driven after the meter shift was observed).

Meter factors and unit conversion factors are combined into a single Scale Factor in the EFA Collect.Inf file. If the flow rate is being read from the field in bb/day the scale factor for a meter is:

$$S=0.00069444M$$

where:

S is the scale factor
M is the meter factor

In reality we adjust an existing scale factor to reduce the indicated leak volume rather than utilize a meter factor.

One way to calculate a new scale factor for a meter is:

Obtain the current meter scale factor S using the following method:

GPB Leak Detection System Overview

- Bring up the LeakNet computer display (using VNC).
- Bring up the online editor: click the "Configure" button on the "EFA Collect" window.
- Select the meter you are going to change. Make sure the meter is in the correct pipe segment.
- The editor dialog box should show the current scale factors. If this meter is the sum of several meters, you will have to pick the correct scaling factor. Usually this is fairly obvious, they are in order (e.g. Meter 160, 161 & 162). You can make absolutely sure by checking the register address in the LeakNet editor dialog box against the one listed on the SetCim history display for that tag (pull up the SetCim detail display, and select the "Point History Panel" button). The register address will be in the top right corner listed as Address. It should look something like HR40446. The EFA Collect.inf file does not record the HR suffix.
- Get average daily leak volume V (bbl). Typically this will be the 24-hour accumulator and is displayed on the SetCim display. The number used in the formula (V) must be positive, so if you have a -230 bbl leak use 230 for V .
- Get the average daily meter flow rate Q (bpd). These are available on the SetCim EFA Inputs screen.

Calculate the correction factor C :

$$C = 1 + V/Q$$

Note:

Now determine if the flow through a meter needs to increase or decrease for the segment to be in balance. If the leak volume is positive then less volume is measured at the outlet than at the inlet. An outlet needs to increase and an inlet meter needs to decrease. If the leak volume is negative then more volume is measured at the outlet than at the inlet. An outlet meter needs to decrease and an inlet meter needs to increase.

If you need to reduce flow through the meter to reduce the indicated leak volume, the new scale factor S^* is:

$$S^* = S/C$$

If you need to increase flow through the meter to reduce the indicated leak volume, the new scale factor S^* is:

$$S^* = SC$$

- Change the scale factor in the Editor dialog on the LeakNet display to S^* .

GPB Leak Detection System Overview

hit "Apply" and "Done" buttons.

- Record the change in C:\Program Files\EFA Collect\EFA Collect.inf. Add a comment at the top of the file describing the change, then skip down into the file and change the meter factor in the section for that meter.

Example:

A 230 bbl leak volume on segment1 (Lisburne) has been present for a day or two. The pipeline has a potential leak. The pipe has been driven and no leak was found. The daily rate on the inlet meter is running about 65000 bbl/day. The current scale factor for the Lisburne end meter is 0.00069415. The correction factor would be:

$$C = 1 + 230/65000 = 1.003538$$

The leak volume is positive, so we need to decrease the inlet flow, or increase the outlet flow. In this case we are adjusting the inlet flow so the new scale factor is:

$$S' = S / C = 0.00069415 / 1.003538 = 0.00069170$$



Appendix 3 Corrosion Management System

This section summarizes the Corrosion Management System (CMS) in use at Greater Prudhoe Bay (GPB) Performance Unit. Figure 7 contains a schematic of a typical production facility configuration. A map and brief description of each field and the associated production facilities can be found in Figure 8 and GPB Table 3.1.

Appendix 3.1 Corrosion Management System

Appendix 3.1.1 Description

The Corrosion Management System consists of a number of major program elements: Corrosion Monitoring, Erosion Monitoring, Corrosion Mitigation, Inspection and Fitness-For-Service assessment, which follow a simple management process, represented in Figure 1. The CMS elements are summarized in Table 9, Table 10 and Table 11, at the end of this section. The Corrosion, Inspection and Chemical (CIC) Group utilizes data presented in this report as part of the overall Corrosion Management System.

The overall objective of the CMS is to meet the corporate objectives of 'no accidents, no harm to people and no damage to the environment' which translates for corrosion management within BPXA to delivering a mechanical integrity program which:

- Minimizes health, safety, and environmental impacts of corrosion resulting from a loss of containment.
- Provides an infrastructure fit-for-service for the remainder of the life of the oilfield.
- Provides infrastructure of sufficient mechanical integrity capable of producing satellite fields/accumulations through existing main production facilities and infrastructure.
- Provides an infrastructure to support future major gas production and sales through current North Slope facilities.

These overall goals and objectives are achieved through a comprehensive Corrosion Management System that consists of an integrated system of strategy, processes and programs.