

ALASKA LEGISLATURE COMMITTEE FILES 1995-1996 8672

9086 SENATE TRANSPORTATION 577

1
2
3
4
5
6
7
8
9
10
11
12
13
14
15
16
17
18
19
20
21
22
23
24
25
26
27
28
29
30
31

V. TERMINATION OF CONTRACT.

A third-party agent or the department may terminate this agreement for any reason by providing 60-days' written notice of termination to the other party.

VI. NONASSIGNABILITY.

This agreement and the third-party agent's certification are not assignable by the third-party agent, either in whole or in part.

VII. WAIVERS AND SEVERABILITY.

A waiver by either party of a provision of this agreement may not act as a waiver of another provision of this agreement. If a provision of this agreement is for any reason declared invalid, illegal, or unenforceable, that declaration does not affect the remainder of the provisions of this agreement.

VIII. APPLICABLE LAW.

A dispute between the parties in this agreement as to the application, meaning, or interpretation of any part of this agreement shall be resolved in the State of Alaska by application of Alaska law.

IN WITNESS WHEREOF, the parties hereto have executed this agreement on the date written above.

(THIRD-PARTY AGENT)

SIGNATURE: _____

NAME: _____

TITLE: _____

(DEPARTMENT OF PUBLIC SAFETY)

SIGNATURE: _____

NAME: _____

TITLE: Director, Division of Motor Vehicles.

(b) The contract required under AS 28.12.010(b) for a third-party registrar must read substantially as follows:

AGREEMENT

between the

DEPARTMENT OF PUBLIC SAFETY

and a

THIRD-PARTY REGISTRAR

THIS AGREEMENT is made and entered into this _____ day of _____, 19____, by and between the Department of Public Safety (hereinafter the department) and _____ (hereinafter the third-party registrar)

LOCATED AT (third-party registrar address)

This agreement authorizes the named third-party registrar to administer registration and titling as provided under AS 28.12.010(a)(2) on behalf of the department. The department and the third-party registrar, for good and valuable consideration and under the terms and conditions set out in this agreement, mutually agree as follows:

I. TERM OF AGREEMENT. RENEWALS.

This agreement is effective on the date of execution and shall replace any comparable agreement previously executed between the parties. This agreement shall expire three years after execution, but may be renewed for additional periods, provided that any renewal is set out in writing and that the renewal is signed by a duly authorized representative of each party.

II. THE DEPARTMENT AGREES TO:

(1) Permit the third-party registrar to administer registration and titling described under AS 28.12.010(a)(2), under the terms of this agreement and all of the provisions set out in AS 28.12 and applicable provisions of other state and federal law

(2) Administer and enforce the provisions of AS 28.12.

(3) Conduct an on-site inspection of third-party registrar facilities, and regular electronic audits of third-party registrar books and records.

(4) Prepare a written report of the results of each inspection and audit and provide a copy of the report to the third-party registrar.

(5) Provide the following materials and equipment:

1
2
3
4
5
6
7
8
9
10
11
12
13
14
15
16
17
18
19
20
21
22
23
24
25
26
27
28
29
30
31

III. THE THIRD-PARTY REGISTRAR AGREES:

(1) To comply with all applicable statutes and administrative regulations of the State of Alaska, with all applicable federal laws, including regulations of the Federal Highway Administration, and with all applicable municipal ordinances.

(2) That the state and its employees are not civilly liable for an act or omission of the third-party registrar in performing duties described under AS 28.12 or an act or omission under this agreement.

(3) To cooperate with the Department of Public Safety in performing the duties imposed under this contract and AS 28.12

(4) To keep all driver licensing records confidential.

IV. COMMUNICATIONS.

The third-party registrar designates the following individual at the following address to be its representative to receive the written notices and communications that are desired or required under this agreement:

Telephone () _____

The department designates the following individual at the following address to be its representative to receive the written notices and communications that are desired or required under this agreement:

Director

Division of Motor Vehicles

Telephone () _____

1
2
3
4
5
6
7
8
9
10
11
12
13
14
15
16
17
18
19
20
21
22
23
24
25
26
27
28
29
30
31

Fax () _____

A mailed notice shall be considered given when mailed at a United States post office or official United States mail depository.

V. TERMINATION OF CONTRACT.

A third-party registrar or the department may terminate this agreement for any reason by providing 60-days' written notice of termination to the other party.

VI. NONASSIGNABILITY.

This agreement and the third-party registrar's certification are not assignable by the third-party registrar, either in whole or in part.

VII. WAIVERS AND SEVERABILITY.

A waiver by either party of a provision of this agreement may not act as a waiver of another provision of this agreement. If a provision of this agreement is for any reason declared invalid, illegal, or unenforceable, that declaration does not affect the remainder of the provisions of this agreement.

VIII. APPLICABLE LAW.

A dispute between the parties in this agreement as to the application, meaning, or interpretation of any part of this agreement shall be resolved in the State of Alaska by application of Alaska law.

IN WITNESS WHEREOF, the parties hereto have executed this agreement on the date written above.

(THIRD-PARTY REGISTRAR)

SIGNATURE:

NAME: _____

TITLE: _____

(DEPARTMENT OF PUBLIC SAFETY)

SIGNATURE: _____

NAME: _____

TITLE: Director, Division of Motor Vehicles.

(c) The contract required under AS 28.12.010(b) for a third-party examiner must read substantially as follows:

AGREEMENT

1
2
3
4
5
6
7
8
9
10
11
12
13
14
15
16
17
18
19
20
21
22
23
24
25
26
27
28
29
30
31

between the
DEPARTMENT OF PUBLIC SAFETY
and a
THIRD-PARTY EXAMINER

THIS AGREEMENT is made and entered into this _____ day of _____, 19____, by and between the Department of Public Safety (hereinafter the department) and _____ (hereinafter the third-party examiner)

LOCATED AT (third-party examiner address)

This agreement authorizes the named third-party examiner to administer driver's license examinations and issue licenses or permits as required under AS 28.12.010(a)(3) on behalf of the department. The department and the third-party examiner, for good and valuable consideration and under the terms and conditions set out in this agreement, mutually agree as follows:

I. TERM OF AGREEMENT: RENEWALS.

This agreement is effective on the date of execution and shall replace any comparable agreement previously executed between the parties. This agreement shall expire three years after execution, but may be renewed for additional periods, provided that any renewal is set out in writing and that the renewal is signed by a duly authorized representative of each party.

II. THE DEPARTMENT AGREES TO:

(1) Permit the third-party examiner to administer testing described under AS 28.12.010(a)(3), including driver's license skills tests, under the terms of this agreement and all of the provisions set out in AS 28.12 and applicable provisions of other state and federal law.

(2) Administer and enforce the provisions of AS 28.12.

(3) Conduct an on-site inspection of third-party examiner facilities, and regular

1
2
3
4
5
6
7
8
9
10
11
12
13
14
15
16
17
18
19
20
21
22
23
24
25
26
27
28
29
30
31

electronic audits of third-party examiner books and records.

(4) Conduct an annual performance evaluation and audit of the driving skills test administered by the third-party examiner.

(5) Prepare a written report of the results of each inspection and audit and provide a copy of the report to the third-party examiner.

(6) Provide the following materials and equipment:

III. THE THIRD-PARTY EXAMINER AGREES:

(1) To comply with all applicable statutes and administrative regulations of the State of Alaska, with all applicable federal laws, including regulations of the Federal Highway Administration, and with all applicable municipal ordinances.

(2) To provide insurance as required by AS 28.12.150.

(3) That the state and its employees are not civilly liable for an act or omission of the third-party examiner in performing duties described under AS 28.12 or an act or omission under this agreement.

(4) To cooperate with the Department of Public Safety in performing the duties imposed under this contract and AS 28.12.

(5) To keep all driver licensing records confidential.

IV. COMMUNICATIONS.

The third-party examiner designates the following individual at the following address to be its representative to receive the written notices and communications that are desired or required under this agreement:

Telephone () _____

1
2
3
4
5
6
7
8
9
10
11
12
13
14
15
16
17
18
19
20
21
22
23
24
25
26
27
28
29
30
31

The department designates the following individual at the following address to be its representative to receive the written notices and communications that are desired or required under this agreement:

Director
Division of Motor Vehicles

Telephone () _____

Fax () _____

A mailed notice shall be considered given when mailed at a United States post office or official United States mail depository.

V. TERMINATION OF CONTRACT.

A third-party examiner or the department may terminate this agreement for any reason by providing 60-days' written notice of termination to the other party.

VI. NONASSIGNABILITY.

This agreement and the third-party examiner's certification are not assignable by the third-party examiner, either in whole or in part.

VII. WAIVERS AND SEVERABILITY.

A waiver by either party of a provision of this agreement may not act as a waiver of another provision of this agreement. If a provision of this agreement is for any reason declared invalid, illegal, or unenforceable, that declaration does not affect the remainder of the provisions of this agreement.

VIII. APPLICABLE LAW.

A dispute between the parties in this agreement as to the application, meaning, or interpretation of any part of this agreement shall be resolved in the State of Alaska by application of Alaska law.

IN WITNESS WHEREOF, the parties hereto have executed this agreement on the date written above.

(THIRD-PARTY EXAMINER)

SIGNATURE: _____

NAME: _____

1 TITLE: _____

2 (DEPARTMENT OF PUBLIC SAFETY)

3 SIGNATURE: _____

4 NAME: _____

5 TITLE: Director, Division of Motor Vehicles.

6 Sec. 28.12.130. ON-SITE INSPECTIONS AND AUDITS. (a) An applicant
7 for a third-party agent, registrar, or examiner certificate shall permit the department to
8 conduct preapproval inspections and to electronically audit its operations, facilities, and
9 records relating to its third-party agent, registrar, or examiner program, for the purpose
10 of determining whether the applicant is qualified to participate in the program. A
11 third-party agent, registrar, or examiner who has been certified and has executed an
12 agreement described under AS 28.12.120 shall permit the department to inspect and
13 audit its third-party agent, registrar, or examiner program to determine whether it
14 continues in compliance with the requirements of this chapter. The department may
15 perform an inspection or audit with or without prior notice to the third-party agent,
16 registrar, or examiner.

17 (b) An inspection or audit must include, at a minimum, an examination of

18 (1) records relating to the third-party agent, registrar, or examiner
19 program;

20 (2) evidence of compliance with this title;

21 (3) the following if the person is a third-party agent or examiner,

22 (A) skills testing procedures, practices, and operations;

23 (B) vehicles used for testing; and

24 (C) effectiveness of the driving skills test program by either
25 testing a sample of drivers who have been issued certificates evidencing that
26 they have passed the driving skills test administered by the third-party agent
27 or examiner or by having department employees or designees take the driving
28 skills test from a third-party agent or examiner.

29 (b) The department shall prepare a written report of an inspection or audit.

30 A copy of the report shall be provided to the third-party agent, registrar, or examiner.

31 Sec. 28.12.140. ADVERTISING. (a) A third-party agent or examiner may

1 not advertise in a manner that indicates in any way that the third-party agent or
2 examiner can guarantee the issuance of a driver's license or imply that the third-party
3 agent or examiner can in any way influence the department in the issuance of a
4 driver's license or imply that preferential or advantageous treatment from the
5 department can be obtained.

6 (b) A third-party agent, registrar, or examiner that is certified by the
7 department may advertise that the third-party agent, registrar, or examiner is
8 "certified," but may not indicate that the agent, registrar, or examiner is approved,
9 sanctioned, or in any other way endorsed by the department, and may not use any
10 other name besides the name on the application for certification. A third-party agent,
11 registrar, or examiner may not use "state" in any part of the third-party agent's,
12 registrar's, or examiner's business name, except when the name does not contain a
13 reference to the person's status as a third-party agent, registrar, or examiner.

14 Sec. 28.12.150. INSURANCE REQUIREMENTS. (a) A third-party agent or
15 examiner shall maintain insurance coverage that meets the requirements of
16 AS 28.22.101 on motor vehicles owned by or registered to a third-party agent or
17 examiner.

18 (b) In addition to the requirements of (a) of this section, a third-party agent or
19 examiner shall maintain bodily injury and property damage liability insurance coverage
20 on motor vehicles owned or used by the third-party agent or examiner to administer
21 skills tests in this state. The amount of insurance coverage required under this
22 subsection may not be less than \$1,000,000 for bodily injury to or death of one or
23 more persons in any one accident and not less than \$250,000 for injury to or
24 destruction of property of others in any one accident.

25 (c) A third-party agent or examiner shall maintain insurance coverage that does
26 not exclude from coverage a person taking a driving skills test administered by the
27 third-party agent or examiner, any person suffering bodily injury or sustained property
28 damage as a result of a driving skills test administered by the third-party agent or
29 examiner.

30 (d) As evidence of required insurance coverage, a third-party agent or
31 examiner shall file with the department a certificate of insurance issued by an

1 insurance company licensed to do business in this state or a certificate of self-insurance
2 approved by the department. A certificate of insurance or self-insurance must include
3 the make, model, year, and vehicle identification number of each vehicle that is used
4 by the third-party agent or examiner to administer a driving skills test.

5 (c) A third-party agent or examiner may not use a motor vehicle to administer
6 a driving skills test unless the vehicle is insured as required by law.

7 (f) The department may cancel a contract with a third-party agent or examiner
8 upon determining that the third-party agent or examiner has failed to file a certificate
9 of insurance or self-insurance or has failed to maintain insurance coverage.

10 Sec. 28.12.160. CIVIL LIABILITY. (a) Unless the action is found to have
11 resulted from gross negligence or a reckless or intentional act, a third-party agent,
12 registrar, or examiner authorized under this section to perform a registration, titling,
13 or licensing function may not be held civilly liable for performing or failing to perform
14 the function.

15 (b) A person may not bring a civil action against the state or an employee of
16 the state to recover civil damages resulting from an act or omission of a third-party
17 agent, registrar, or examiner in performing duties described under this chapter.

18 * Sec. 2. AS 28.15.081(d) is amended to read: - *Added*

19 (d) The department may enter into agreements with other state agencies,
20 municipalities, or qualified persons for the purpose of conducting the examinations,
21 including commercial driver's license examinations, required under this chapter.

22 * Sec. 3. AS 36.30.850(b) is amended by adding a new paragraph to read:

23 (34) a contract between the Department of Public Safety and a third-
24 party agent, registrar, or examiner under AS 28.12.

25 * Sec. 4. TRANSITION. (a) The Department of Public Safety shall implement the
26 provisions of this Act by July 1 of the year following the effective date of this Act.

27 (b) A contract existing on the effective date of this Act between the Department of
28 Public Safety and a third-party agent, registrar, or examiner for the purpose of performing
29 registration, titling, or licensing functions remains in effect under its terms notwithstanding
30 the provisions of this Act.

9-LS0343V
Ford
4/2/96

As compared to
CS workdraft 3/27/96

SENATE CS FOR CS FOR HOUSE BILL NO. 210(TRA)
IN THE LEGISLATURE OF THE STATE OF ALASKA
NINETEENTH LEGISLATURE - SECOND SESSION

BY THE SENATE TRANSPORTATION COMMITTEE

Offered:
Referred:

Sponsor(s): REPRESENTATIVES VEZEY, Kelly

A BILL

FOR AN ACT ENTITLED

1 "An Act relating to issuance of motor vehicle registrations and titles, and to
2 licenses and permits to operate a motor vehicle."

3 BE IT ENACTED BY THE LEGISLATURE OF THE STATE OF ALASKA:

4 * Section 1. AS 28 is amended by adding a new chapter to read:

5 CHAPTER 12. THIRD-PARTY REGISTRATION, TITLING, AND TESTING.

6 Sec. 28.12.010. THIRD-PARTY REGISTRATION, TITLING, AND
7 TESTING. (a) The department may establish a program that authorizes

8 (1) third-party agents to

9 (A) process applications for registration of motor vehicles and
10 issue registration certificates and plates as required under AS 28.10;

11 (B) process applications for certificates of titles and issue
12 certificates of title as required under AS 28.10.201 - 28.10.261; and

13 (C) administer driver's license examinations as required under
14 AS 28.15.081 and issue licenses or permits as provided under AS 28.15;

1
2
3
4
5
6
7
8
9
10
11
12
13
14
15
16
17
18
19
20
21
22
23
24
25
26
27
28
29
30
31

(2) third-party registrars to

(A) process applications for registration of motor vehicles and issue registration certificates and plates as required under AS 28.10; and

(B) process applications for certificates of titles and issue certificates of title as required under AS 28.10.201 - 28.10.261;

(3) third-party examiners to administer driver's license examinations as required under AS 28.15.081 and issue licenses or permits as provided under AS 28.15.

(b) The department may utilize third-party agents, registrars, and examiners to perform the functions described under (a) of this section. A person may not be or act as a third-party agent, registrar, or examiner unless the person satisfies the requirements of this chapter and other applicable law and enters into a contract with the department ^{deleted} as set out in AS 28.12.120 - ^{CAS 28.12.120 was the} that specifies the duties of the third-party agent, registrar, or examiner.

Contract Section

Sec. 28.12.020. CERTIFICATION OF AGENTS, REGISTRARS, AND EXAMINERS. (a) An application for third-party agent, registrar, or examiner certification shall be filed with the department on a form prescribed by the department.

(b) If the department determines that an individual is qualified under this chapter as a third-party agent, registrar, or examiner, the department shall issue to the individual an identification number for electronic record keeping purposes and a certificate indicating the individual is qualified and authorized to perform the functions as provided under AS 28.12.010(a). A third-party agent, registrar, or examiner shall prominently display the certificate in the agent's place of business.

(c) A certificate is effective on the date of issuance and expires three years after issuance. A renewal application form must be filed with the department not less than 30 days before the time the certification expires.

(d) In reviewing an application submitted by a third-party agent or examiner, the department shall also review the driving record of an individual performing functions as an agent or examiner. If the record is satisfactory and the individual is otherwise qualified under this chapter, the prospective agent or examiner may be scheduled for third-party agent or examiner training.

Sec. 28.12.030. REQUIREMENTS FOR THIRD-PARTY AGENTS. The

1 department may not certify a third party agent unless the third-party agent meets all
2 of the conditions set out in this section. The third-party agent shall

3 (1) meet all applicable requirements of law;

4 (2) allow the department to conduct random examinations, inspections,
5 and audits of operating facilities and records as provided under AS 28.12.120;

6 (3) allow the department to conduct annual on-site inspections,
7 evaluations, and audits of operations, facilities, and records;

8 (4) transmit the original forms and reports to the department as required
9 by the department;

10 (5) conduct skills tests as required under AS 28.15 and provide that
11 applicants who fail to successfully complete driving skills testing are not tested more
12 than once in a seven-day period, unless the original test failure was due to vehicle or
13 document deficiencies;

14 (6) issue written certification, on a form provided by the department,
15 to each driver-applicant who passes the driving skills test administered by the third-
16 party agent;

17 (7) attend all training courses, workshops, seminars, and other
18 instructional meetings, as required by the department;

19 (8) provide information and reports to the department, upon request,
20 concerning a complaint against the third-party agent;

21 (9) transmit to the department all fees imposed under this title that are
22 collected as required under AS 28.12.100;

23 (10) ensure that at least 95 percent of the forms submitted to the
24 department are error free;

25 (11) comply with the provisions of AS 28.12.050(2) and (5) - (8).

26 Sec. 28.12.040. REQUIREMENTS FOR THIRD-PARTY REGISTRARS. The
27 department may not certify a person as a third-party registrar unless the person
28 complies with provisions of AS 28.12.030(1) - (4), (7), (9), and (10).

29 Sec. 28.12.050. REQUIREMENTS FOR THIRD-PARTY EXAMINERS. An
30 examiner applicant shall meet the conditions set out in this section in order to qualify
31 and maintain qualification as a third-party examiner. The examiner shall

- 1 (1) comply with the provisions of AS 28.12.030(1) - (3), (5), (6), and
2 (8) - (10);
- 3 (2) hold a valid driver's license required for operation of the motor
4 vehicle used in the driving skills test conducted by the examiner;
- 5 (3) have successfully completed an examiner training workshop and
6 certified examiner program conducted or approved by the department;
- 7 (4) attend all training courses, workshops, seminars, and other
8 instructional meetings as required by the department;
- 9 (5) have a driving record that indicates the applicant is competent to
10 operate a motor vehicle safely;
- 11 (6) have not had a conviction or administrative license action for any
12 of the following violations under the law of this state or a local ordinance or a law or
13 local ordinance of another state substantially similar to the law of this state, during the
14 five-year period preceding application or during the time the individual is an examiner:
- 15 (A) operating a vehicle while intoxicated in violation of
16 AS 28.33.030 or AS 28.35.030;
- 17 (B) refusal to submit to a blood alcohol or breath test in
18 violation of AS 28.35.032;
- 19 (C) failure to stop and provide identification after a personal
20 injury or property damage accident in violation of AS 28.35.060;
- 21 (D) driving without insurance in violation of AS 28.22.011;
- 22 (E) a felony;
- 23 (7) while performing duties as an examiner and during the five year
24 period preceding application, have not had a driver's license suspended, revoked,
25 denied, cancelled or disqualified, or been subjected to a driver's license sanction
26 ordered by the department or a court;
- 27 (8) be at least 21 years of age and have at least three years of
28 experience in driving a motor vehicle;
- 29 (9) transmit the original forms and reports to the department as required
30 by the department.

31 Sec. 28.12.060. PROFESSIONAL CONDUCT. (a) A third-party agent or

1 examiner may not provide a driver's license applicant answers to questions on a
2 knowledge or driving skills test or other driver examination.

3 (b) A third-party agent, registrar, or examiner shall provide services in a
4 professional manner.

5 (c) A third-party agent or examiner who gives driving skills tests may not be
6 an employee of or receive compensation from a driving school.

7 (d) A third-party agent, registrar, or examiner may not consume intoxicating
8 beverages or controlled substances within eight hours before or during licensing or
9 testing activities and may not be under the influence of intoxicating beverages during
10 licensing or testing activities. In this subsection,

11 (1) "controlled substance" has the meaning given in AS 28.33.190 but
12 does not include a drug prescribed for that person by a physician licensed in this state
13 and used as required by the prescription, unless the prescribed drug affects the ability
14 of a person to safely operate a motor vehicle: *changed from 0.04 to 0.02*

15 (2) "under the influence" includes 0.02 percent or more by weight of
16 alcohol in the person's blood or *changed from 40 to 20* milligrams or more of alcohol per 100 milliliters
17 of blood, or when there is 0.02 grams or more per 210 liters of the person's breath.

18 Sec. 28.12.070. NOTIFICATION REQUIREMENTS. (a) A third-party agent,
19 registrar, or examiner shall notify the department in writing within

20 (1) 30 days before a change in name or address;

21 (2) 10 days of any of the following:

22 *deleted "a criminal* (A) *complaint"* a civil action resulting from duties imposed under this
23 chapter, or a complaint regarding driving skills test administration received by
24 the agent or examiner;

25 (B) ceasing business operations in the state.

26 (b) A third-party agent or examiner shall notify the department as follows:

27 (1) before the end of the next business day after the agent or examiner
28 receives notice of any suspension, revocation, cancellation, or disqualification of the
29 agent's or examiner's driver's license ordered by a court or the department;

30 (2) within 10 days after being convicted or found responsible for
31 violation of a law or local ordinance of any state relating to motor vehicle traffic

1 control, other than a parking violation; —

2 ^{added} (3) before the end of the next business day after the agent or examiner
3 is charged with a crime.

4 Sec. 28.12.080. TEST ADMINISTRATION. A driving skills test shall be
5 conducted strictly in accordance with the provisions of this title and the test
6 specifications and procedures prescribed by the department. A driving skills test shall
7 be conducted in a vehicle that is representative of the class and type of vehicle for
8 which the applicant seeks to be licensed and for which the third-party examiner is
9 qualified to test. Before testing, the third-party agent or examiner shall inspect the
10 vehicle to verify that it is empty, meets applicable motor carrier safety regulations,
11 is equipped as required by law, and is otherwise safe to operate.

12 Sec. 28.12.090. TERMINATION OF THIRD-PARTY AGENT, REGISTRAR,
13 OR EXAMINER CERTIFICATE. (a) The department may cancel or suspend the
14 certificate of a third-party agent, registrar, or examiner after determining that the agent,
15 registrar, or examiner has done one or more of the following:

16 (1) failed to comply with or satisfy any of the provisions of the contract
17 required under AS 28.12.010(b);

18 (2) falsified a record or information relating to the third-party agent,
19 registrar, or examiner program;

20 (3) committed any act or omission that compromises the integrity of
21 the third-party agent, registrar, or examiner program: before making a determination
22 under this paragraph, the department shall provide the agent, registrar, or examiner the
23 opportunity for a hearing as provided under AS 28.05.141; or ^{added} (deleted provision for
arbitration)

24 (4) acted as a third-party agent or examiner without a valid driver's
25 license, when the agent's or examiner's driver's license has been suspended or
26 revoked, when the agent's or examiner's certificate has been cancelled, or when the
27 agent's or examiner's application for a driver's license has been denied.

28 (b) If the department determines that grounds for termination of a third-party
29 agent's, registrar's, or examiner's certificate exist and that the grounds relate to a
30 failure to comply with or satisfy the requirements for a certificate or under the contract
31 required under AS 28.12.010(b), the department shall suspend the certificate. If the

1
2
3
4
5
6
7
8
9
10
11
12
13
14
15
16
17
18
19
20
21
22
23
24
25
26
27
28
29
30
31

Deleted Sec 28.12.120 REQUIRED CONTRACT

department determines that the third-party agent, registrar, or examiner has corrected the deficiency, the department may reinstate the certificate.

Sec. 28.12.100. COLLECTION OF FEES AND COMPENSATION TO AGENTS. If the third-party agent, registrar, or examiner performs a function for which a fee is imposed under this title, the third-party agent, registrar, or examiner shall collect the statutory fee on behalf of the department and may collect and retain a fee as compensation for performing the function. The fee due the third-party agent, registrar, or examiner shall be set by the agent, registrar, or examiner, subject to approval by the department. The third-party agent, registrar, or examiner shall retain any amount due the agent, registrar, or examiner as provided under this section and remit the amount collected on behalf of the department as determined by contract. Fee collection and remission procedures are subject to approval by the department.

Sec. 28.12.110. DEPARTMENT REVIEW OF LICENSING APPLICATIONS. The department may reject an application approved by a third-party agent, registrar, or examiner if the application fails to comply with a provision of AS 28.10 or AS 28.15. The department shall allow an applicant whose application is rejected under this section to reapply to the department.

^{New Section Number}
Sec. 28.12.120. ON-SITE INSPECTIONS AND AUDITS. (a) An applicant for a third-party agent, registrar, or examiner certificate shall permit the department to ^{Deleted "preapproval"} conduct inspections and to electronically audit its operations, facilities, and records relating to its third-party agent, registrar, or examiner program, for the purpose of determining whether the applicant is qualified to participate in the program. A third-party agent, registrar, or examiner who has been certified and has executed an agreement described under AS 28.12.010(b) shall permit the department to inspect and audit its third-party agent, registrar, or examiner program to determine whether it continues in compliance with the requirements of this chapter. The department may perform an inspection or audit ^{Deleted with or} without prior notice to the third-party agent, registrar, or examiner.

(b) An inspection or audit must include, at a minimum, an examination of
(1) records relating to the third-party agent, registrar, or examiner program;

1 (2) evidence of compliance with this title;

2 (3) the following if the person is a third-party agent or examiner,

3 (A) skills testing procedures, practices, and operations;

4 (B) vehicles used for testing; and

5 (C) effectiveness of the driving skills test program by either
6 testing a sample of drivers who have been issued certificates evidencing that
7 they have passed the driving skills test administered by the third-party agent
8 or examiner or by having department employees or designees take the driving
9 skills test from a third-party agent or examiner.

10 (c) The department shall prepare a written report of an inspection or audit. A
11 copy of the report shall be provided to the third-party agent, registrar, or examiner.

12 Sec. 28.12.130. ADVERTISING. (a) A third-party agent or examiner may
13 not advertise in a manner that indicates in any way that the third-party agent or
14 examiner can guarantee the issuance of a driver's license or imply that the third-party
15 agent or examiner can in any way influence the department in the issuance of a
16 driver's license or imply that preferential or advantageous treatment from the
17 department can be obtained.

18 (b) A third-party agent, registrar, or examiner that is certified by the
19 department may advertise that the third-party agent, registrar, or examiner is
20 "certified," but may not indicate that the agent, registrar, or examiner is approved,
21 sanctioned, or in any other way endorsed by the department, and may not use any
22 other name besides the name on the application for certification. A third-party agent,
23 registrar, or examiner may not use "state" in any part of the third-party agent's,
24 registrar's, or examiner's business name, except when the name does not contain a
25 reference to the person's status as a third-party agent, registrar, or examiner.

26 Sec. 28.12.140. INSURANCE REQUIREMENTS. (a) A third-party agent or
27 examiner shall maintain insurance coverage that meets the requirements of
28 AS 28.22.101 on motor vehicles owned by or registered to a third-party agent or
29 examiner.

30 (b) In addition to the requirements of (a) of this section, a third-party agent or
31 examiner shall maintain bodily injury and property damage liability insurance coverage

1 on motor vehicles owned or used by the third-party agent or examiner to administer
 2 skills tests in this state. The amount of insurance coverage required under this
 3 subsection may not be less than \$1,000,000 for bodily injury to or death of one or
 4 more persons in any one accident and not less than \$250,000 for injury to or
 5 destruction of property of others in any one accident.

6 (c) A third-party agent or examiner shall maintain insurance coverage that does
 7 not exclude from coverage a person taking a driving skills test administered by the
 8 third-party agent or examiner, any person suffering bodily injury or sustained property
 9 damage as a result of a driving skills test administered by the third-party agent or
 10 examiner.

11 (d) As evidence of required insurance coverage, a third-party agent or
 12 examiner shall file with the department a certificate of insurance issued by an
 13 insurance company licensed to do business in this state or a certificate of self-insurance
 14 approved by the department. A certificate of insurance or self-insurance must include
 15 the make, model, year, and vehicle identification number of each vehicle that is used
 16 by the third-party agent or examiner to administer a driving skills test.

17 (e) A third-party agent or examiner may not use a motor vehicle to administer
 18 a driving skills test unless the vehicle is insured as required by law.

19 (f) The department may cancel a contract with a third-party agent or examiner
 20 upon determining that the third-party agent or examiner has failed to file a certificate
 21 of insurance or self-insurance or has failed to maintain insurance coverage.

Deleted Sec 28.12.160 CIVIL LIABILITY

22 • Sec. 2. AS 28.15.081(d) is amended to read:

23 (d) The department may enter into agreements with other state agencies,
 24 municipalities, or qualified persons for the purpose of conducting the examinations,
 25 including commercial driver's license examinations, required under this chapter.

26 • Sec. 3. AS 36.30.850(b) is amended by adding a new paragraph to read:

27 (34) a contract between the Department of Public Safety and a third-
 28 party agent, registrar, or examiner under AS 28.12.

29 • Sec. 4. TRANSITION. (a) The Department of Public Safety shall implement the
 30 provisions of this Act by July 1 of the year following the effective date of this Act.

31 (b) A contract existing on the effective date of this Act between the Department of

1 Public Safety and a third-party agent, registrar, or examiner for the purpose of performing
2 registration, titling, or licensing functions remains in effect under its terms notwithstanding
3 the provisions of this Act.

SENATE COMMITTEE REPORT
First Committee of Referral

DATE: 2/9/96

FURTHER: State Affairs

Date of 5-Day Notice: 3/14/96
 (in accordance with Uniform Rule 23)

DATE TURNED INTO OFFICE: 4/12/96

The Transportation Committee considered CS FOR HOUSE BILL NO. 210(STA) am

Relating to issuance of motor vehicle registrations and titles, and to licenses and permits to operate a motor vehicle.

and recommends:

be replaced with S CS HB 210 (TRA)

adopt previous CS ()

attached amendment(s)

adopt Letter of Intent by _____ Committee

further referral to the _____ Committee

Senate Bill:
 same title
 new title
 House Bill:
 same title
 technical title
 new: SCR° _____

SIGNING DO PASS	DP	OTHER RECOMMENDATIONS	NR	DNP	AM
<i>Adrian L. Taylor</i>	<input checked="" type="checkbox"/>	<i>[Signature]</i>	<input checked="" type="checkbox"/>		
<i>Lyde Green</i>	<input checked="" type="checkbox"/>	<i>[Signature]</i>			
CHAIR: <i>[Signature]</i>		CHAIR: <i>[Signature]</i>	<input checked="" type="checkbox"/>		

NEW FISCAL NOTE(S):

Department	Date	Zero	Fiscal

PREVIOUS FISCAL NOTE(S):*

Department	Date	Zero	Fiscal

APPROPRIATION -- no fiscal note

*include fiscal notes accompanying Governor's bill

FISCAL NOTE

STATE OF ALASKA
1996 LEGISLATIVE SESSION

BILL NO: SCS CSHB 210(TRA)

Revision Date: 4/12/96 Dept. Affected: Public Safety
 Title: An act relating to issuance of motor vehicle registrations and titles, and to licenses..... BRU: Motor Vehicles
 Sponsor: Representative Vezey Component: Field Services
 Requestor: S. TRA COMPONENT SERIAL NO. 0502

EXPENDITURES/REVENUES: (Thousands of Dollars) (inflation not included)

OPERATING	FY 97	FY 98	FY 99	FY 00	FY 01	FY 02
PERSONAL SERVICES						
TRAVEL						
CONTRACTUAL						
SUPPLIES						
EQUIPMENT						
LAND & STRUCTURES						
GRANTS CLAIMS						
MISCELLANEOUS						
TOTAL OPERATING	-0-	-0-	-0-	-0-	-0-	-0-
CAPITAL EXPENDITURES	-0-	-0-	-0-	-0-	-0-	-0-
CHANGE IN REVENUES ()	-0-	-0-	-0-	-0-	-0-	-0-
Revenue Code						

FUNDING: (Thousands of Dollars)

1002 Federal Receipts						
1003 GE Match						
1004 GE						
1005 GE/Program Receipts						
1008 GE/MBTIA						
Other						
TOTAL	-0-	-0-	-0-	-0-	-0-	-0-

Estimate of current year (FY 95) impact \$ _____

POSITIONS:

FULL-TIME	0	0	0	0	0	0
PART-TIME	0	0	0	0	0	0
TEMPORARY	0	0	0	0	0	0

ANALYSIS (Attach a separate page if necessary)

See Attached

Prepared By Charles R. Hosack Phone 260-5559
 Division Motor Vehicles Date 4/12/96
 Approved by Commissioner *Dee Smith* Date 4/12/96
 Agency Ronald L. Otto Dept of Public Safety

PREPARER TO PROVIDE ALL DISTRIBUTION COPIES TO GOVERNOR'S LEGISLATIVE OFFICE

FISCAL NOTE

STATE OF ALASKA
1996 LEGISLATIVE SESSION

BILL NO: SCS CSHB 210(TRA)

Revision Date: 4/12/96

Dept. Affected: Public Safety

ANALYSIS CONTINUED:

This bill gives the Division the authority to utilize contract agents to provide services. The Division already has in place a number of contract agents to provide service in smaller communities where there is no Division office and recently the Division has started a new program to allow emission test stations to register vehicles in Anchorage and Fairbanks. The new program is currently in operation in Anchorage and in the very near future it will be expanded to Fairbanks.

The \$0 amount in this fiscal note is based on the assumption that the Division will maintain the existing agents although the contracts and method of payment may be modified to conform with this bill. The Division will also continue with the existing emission test station program in the Anchorage and Fairbanks areas. These programs are already in the Division's budget plan and the only funding needed is an RPL currently before the LB&A committee to allow the Division to receive and expend funds for the DP costs associated with the new stations.

The Division will continue to explore the feasibility of adding additional contract agents where justified by the workload or where cost efficiencies can be shown. It is recognized that in future years there may be start up costs associated with the training and administrative requirements for new agents. These costs will be addressed as budget increments in the years the agents are established.

FISCAL NOTE

STATE OF ALASKA
1995 LEGISLATIVE SESSION

BILL NO: CSHB 210(TRA)

Revision Date: 4/22/95 Dept. Affected: Public Safety
 Title: An act relating to issuance of motor vehicle BRU: Motor Vehicles
registrations and titles, and to licenses..... Component: Field Services
 Sponsor: Representative Vezey
 Requestor: H. TRA COMPONENT SERIAL NO. 0502

EXPENDITURES/REVENUES: (Thousands of Dollars) (inflation not included)

	FY 96	FY 97	FY 98	FY 99	FY 00	FY 01
OPERATING						
PERSONAL SERVICES						
TRAVEL						
CONTRACTUAL						
SUPPLIES						
EQUIPMENT						
LAND & STRUCTURES						
GRANTS CLAIMS						
MISCELLANEOUS						
TOTAL OPERATING	-0-	-0-	-0-	-0-	-0-	-0-
CAPITAL EXPENDITURES	-0-	-0-	-0-	-0-	-0-	-0-
CHANGE IN REVENUES ()	-0-	-0-	-0-	-0-	-0-	-0-
Revenue Code						

FUNDING: (Thousands of Dollars)

1002 Federal Receipts						
1003 GE Match						
1004 GE						
1005 GE/Program Receipts						
1006 GE/MHTIA						
Other						
TOTAL	-0-	-0-	-0-	-0-	-0-	-0-

Estimate of current year (FY 95) impact \$ _____

POSITIONS:

FULL-TIME	0	0	0	0	0	0
PART-TIME	0	0	0	0	0	0
TEMPORARY	0	0	0	0	0	0

ANALYSIS: (Attach a separate page if necessary)

See Attached

Prepared By Charles R. Mosack Phone: 269-5559
 Division Motor Vehicles Date: 4/22/95
 Approved by Commissioner *Del Smith* Date: 4/22/95
 Agency Ronald L. Otto, Dept. of Public Safety

PREPARER TO PROVIDE ALL DISTRIBUTION COPIES TO GOVERNOR'S LEGISLATIVE OFFICE

For further distribution information call the Governor's Legislative Office

STATE OF ALASKA
1995 LEGISLATIVE SESSION

BILL NO: CSHB 210(TRA)

Revision Date: 4/22/95 Dept. Affected: Public Safety

ANALYSIS CONTINUED

This bill gives the Division the authority to utilize contract agents to provide services. The Division already has in place a number of contract agents to provide service in smaller communities where there is no Division office and recently the Division has started a new program to allow emission test stations to register vehicles in Anchorage and Fairbanks. The new program is currently in operation in Anchorage and in the very near future it will be expanded to Fairbanks.

The \$0 amount in this fiscal note is based on the assumption that the Division will maintain the existing agents although the contracts and method of payment may be modified to conform with this bill. The Division will also continue with the existing emission test station program in the Anchorage and Fairbanks areas. These programs are already in the Division's budget plan and the only funding needed is an RPL currently before the LB&A committee to allow the Division to receive and expend funds for the DP costs associated with the new stations.

The Division will continue to explore the feasibility of adding additional contract agents where justified by the workload or where cost efficiencies can be shown. It is recognized that in future years there may be start up costs associated with the training and administrative requirements for new agents. These costs will be addressed as budget increments in the years the agents are established.

DMV to launch one-stop pilot program

Anchorage drivers soon will be able to take care of the registering and emission testing of their vehicles at one location.

Next month, the Department of Public Safety's Division of Motor Vehicles

will launch a 90-day pilot program to allow vehicles to be registered at certified emission testing centers, according to a press release issued by the department.

"If this partnership between the state and private

business works out, it could save car owners some hassle when registering their vehicles and free up DMV employees for other functions," said Public Safety Commissioner Ron Otte.

for registration/emissions testing

The pilot program will start with Kwik Lube's emission test center at 36th Avenue and Old Seward Highway. It will be equipped to update DMV files and issue new license tags, and will offer on-the-

spot registration for any vehicle that has passed emission testing.

To register cars at the center, drivers need only supply their DMV registration renewal cards received in the mail and a cash,

check or credit-card payment.

If the pilot project proves feasible, the concept could be extended to other certified emission testing facilities in Anchorage and Fairbanks.

Legislative Research Agency

Alaska State Legislature



130 Seward Street, Suite 218
Juneau, Alaska 99801-2196

Phone: (907) 465-3991
Fax: (907) 463-3351

November 25, 1994

MEMORANDUM

TO: Representative Al Vezey

FROM: Patricia Young *P. Young*
Legislative Analyst

RE: Privatizing Motor Vehicle Registration and Drivers' Licensing
Research Request 95.032

You asked for samples of pertinent statutes and regulations from states that have privatized motor vehicle registration and drivers' licensing. You also wished to know if such privatization is considered successful.

Drivers' Licensing Services

A majority of states use third parties for testing the driving skills of operators of *commercial* vehicles, as authorized under the Commercial Motor Vehicle Safety Act of 1986¹. Additionally, many states use third parties or private agents for noncommercial drivers' license *renewals*. According to David Hugel, director of government affairs with the American Association of Motor Vehicle Administrators, however, the use of third-party or private agents for the original

¹The Commercial Motor Vehicle Safety Act of 1986 (43 CFR Section 383) was passed by Congress in an attempt to reduce truck and bus accidents by requiring all commercial drivers to meet standards for procedures, methods, and minimum passing scores. To this end, each commercial driver must qualify for and carry a single commercial driver's license (CLL). The Act requires an inspection of commercial vehicles, an off-road driving test (such as in a parking or loading area), and an on-road test over a predetermined route. Although states generally administer applicant screening and knowledge testing, many state drivers' bureaus are neither trained to inspect commercial vehicles, nor equipped to administer the driving skills tests. States are authorized under the Act to use third parties to administer commercial driving skills tests. *Third party* is defined as "another state, an employer, a private driver training facility or other private institution, or a department, agency or instrumentality of a local government."

Representative Al Vezey

November 25 1994

Page 2

testing and issuance of noncommercial drivers' licenses has only recently been considered in some states.

Arizona relies heavily on third parties for commercial drivers' license (CDL) testing and is considering their use for licensing of noncommercial drivers as well. Statutory language was added last year to allow for third-party testing for noncommercial drivers' licenses. According to a representative of Arizona's Division of Motor Vehicles, the provision is due to go into effect on an experimental basis soon. The intent is to allow high school drivers' training programs to administer "all tests required" in order to determine an applicant's eligibility for a regular passenger automobile or motorcycle driving license. Copies of the pertinent statutes are attached.

Michigan is another state making extensive use of third-party CDL testing. According to Bill Charron, Michigan Office of Traffic Safety, the state screens applicants and administers the knowledge tests, but relies on private agents to administer the vehicle inspections and actual driving tests. Mr. Charron considers the private CDL testing as very successful, and he believes the program could be expanded to noncommercial drivers' licensing as long as the state maintains a strict auditing practice. The pertinent statute in Michigan simply specifies that the state may enter into third-party agreements for driver testing services. A new contract for third-party agents is currently being developed. Mr. Charron is sending a draft copy of the contract, and that contract will be forwarded to your office upon its arrival.

Motor Vehicle Registration

A survey conducted this year by the Office of Legislative Auditor in Minnesota, entitled *Motor Vehicle Deputy Registrars*, suggests that although nearly all states use a central office to regulate motor vehicle registration and title services, many also employ third parties to perform a variety of services.³ The survey contains a useful synopsis of current state regulation and potential approaches for streamlining motor vehicle services of all kinds. The survey is attached along with statutes from Washington and North Dakota. A copy of the contract used in North Dakota is also included.

I hope you find this information useful. Please let us know if we can be of further help.

Attachments

³Office of the Legislative Auditor, State of Minnesota, *Motor Vehicle Deputy Registrars*, March 1994, attached

Legislative Research Agency

Alaska State Legislature



130 Seward Street, Suite 218
Juneau, Alaska 99801-2196

Phone: (907) 465-3991
Fax: (907) 463-3351

April 19, 1995

MEMORANDUM

TO: Representative Al Vezey

FROM: Patricia Young *P. Young*
Legislative Analyst

RE: California Department of Motor Vehicles: Decentralization and Partnerships
with Private Enterprises
Research Request 95.185

You asked for a brief history of the decentralization of the California Department of Motor Vehicles Services. You were also interested in knowing if the department has any plans for privatization or business partnerships.

Gary Nishite, chief of the Office of Technology for the California Department of Motor Vehicles (DMV), provided the following background information. Historically, DMV was the sole provider of vehicle registration and driver licensing services. The only exception was that auto clubs, such as Triple A, were allowed to handle registration paperwork for their clients. Every transaction, however, was processed through the Sacramento office. According to Mr. Nishite, about ten years ago DMV changed its information technology structure in order to decentralize. At the same time, DMV provided the auto clubs with computers and a secure method for entering data, thereby "effectively doubling" the number of field offices across the state.

In addition to this decentralization effort, the state is actively seeking partnerships with other public agencies and with a number of industry clients with business operations similar to DMV's and a frequent need for interface with DMV. These industry clients include automobile rental and leasing companies, automobile clubs, dealers, carriers, and registration service firms. As noted in the DMV document developed as the "System Architecture & Requirements to Support Public/Public & Public/Private Partnerships,"

With the adoption of its *Strategic Business Plan* in June of 1993, DMV formalized a commitment to "actively seek partnerships and new relationships that are in the public interest." In order to better service its customers, DMV is interested in developing partnerships that offer a demonstrable benefit to the people of California

Representative Vezey

April 19, 1995

Page 2

while ensuring that services are provided efficiently, reliably, and conveniently. Within this context, DMV seeks partnerships that offer a bonus of "value-added services," whereby services to our customers are actually enhanced when compared to traditional means of delivery. The Department views partnerships as an "opportunity to share potential risks and benefits with other organizations: risks associated with new technologies, changes in service delivery mechanisms, and new ways of doing business."

According to the *Strategic Business Plan*, DMV will continue to develop alternative methods of service delivery, including the use of kiosks and payment of fees through electronic funds transfer systems. The following is noted under the heading of "Changing organizational relationships with business and government":

The vast majority of transactions with organizations, such as automobile dealers, auto clubs, insurance companies, and California's courts, will be handled by DMV via direct and secure electronic linkages. These linkages will minimize duplication of data entry, support transaction validation against established databases, and speed data transfer. Wherever possible, data will be captured at the source rather than re-entered by DMV (p. 12).

By way of example, Mr. Nishite notes that nearly two years ago, the automobile rental industry approached DMV in an effort to get cars registered and on the road faster. The result was a pilot project whereby DMV supplied Hertz with a terminal in order to key-in data, as well as plates and other materials necessary to get the cars in operation. The project was a success, and consequently, about one year ago, it was expanded to include five or six of the major car rental companies in the state.

Mr. Nishite describes the process of decentralization and partnerships as a "shift in the paradigm" with the dealerships and industry organizations--rather than DMV--being the "center of the universe." He stresses that DMV's ultimate goal is more efficiency and better customer service.

I hope this information is helpful. If you have questions or need more information, please let me know.

Attachments

465-3258

INFO CALIFORNIA PLUS
Spring '95

VENDOR CORNER

PRINTER TECHNOLOGY COULD REVOLUTIONIZE DMV REGISTRATION

San Francisco
Legislative Research Agency

When Dan Gill and Christ Rousseff embarked on their 1987 effort to develop a self-service terminal for motor vehicle registrations, the entrepreneurial duo started from a simple observation: The lines are too long at the DMV.

"Actually, it was a guy from the DMV in Virginia who approached us and said, 'Why don't you guys figure a way to get people out of the lines?' " explained Gill, who previously founded a company providing photo-I.D. equipment to DMV offices across the country. "We said, 'Like what?' And he said, 'How about an ATM device for auto registrations?' "

It sounded like a fair idea. So Gill quickly joined forces with former Polaroid executive Rousseff (whose first name rhymes with "crisp"), raised some venture capital and started looking into self-service terminals. Seven years and \$8 million later, their Marina Del Rey, Calif., company, Image Technology, is seeking to compete for a slice of the motor vehicle registration business in several states. In

addition, they are targeting the market for state validation stickers for everything from hunting licenses to campground reservations.

That's because Image Technology has the patent on a unique printing process that solves a long troublesome puzzle: How to print on reflective, adhesive materials such as auto registration stickers. Several companies have spent years searching for a solution to the vexing problem, which has so far prevented DMV offices from printing personalized registration stickers that could prevent costly sticker fraud and theft. Image Technology's process, developed in partnership with 3M and AT&T, lets them print license plate numbers and bar-coded information directly on the stickers and issue them from a self-service terminal.

"Slowly, a lot of motor vehicle administrators are deciding this (Image Technology) is the way to go," said Gary Nishite, chief of the office of technology for the California Department of Motor Vehicles. The DMV is studying Image

Technology's proposal to take over issuance of the state's 16 million annual registration stickers. "The concept is great, but the question is, can we afford it?"

Nishite and others question the cost-effectiveness of Image Technology's process. Printing individualized stickers would significantly raise the cost per sticker, but cut costs at the other end by eliminating book-keeping, staff and fraud resulting in lost revenues. California's analysis of the potential costs and savings was due to be finished by the end of January. Meanwhile, DMVs in Virginia and several other states are close to issuing requests for proposals on a self-service system. Gill's position on his printer's cost-effectiveness remains optimistic. "Even if it didn't cost justify in (motor vehicle) registration alone, it certainly would when you add all the other applications the system is capable of doing," said Gill. "The driving force is to get a self-service network out there that will help keep the lines down and eventually lower the costs to government." ■

HB

287

SENATE COMMITTEE REPORT

DATE: 5/6/95

FURTHER:

DATE TURNED INTO OFFICE: 5/8/95

Transportation Committee considered HOUSE BILL NO. 287

"An Act relating to outdoor advertising on trash receptacles and restrictions on outdoor advertising."

and recommends:

- be replaced with _____ CS _____
- adopt previous _____ CS _____
- attached amendment(s)
- adopt Letter of Intent by _____ Committee
- further referral to the _____ Committee

Senate Bill:

same title
new title

House Bill:

same title
technical change
new: SCR _____

SIGNING/DO PASS	DP	OTHER RECOMMENDATIONS	NR	DNP	AM
<i>Lynne Green</i>	✓	<i>Advis. to Dept</i> _____	✓		
CHAIR:		<i>Steve Kie</i>	✓		

NEW FISCAL NOTE(S):

Department Date Zero Fiscal

Department	Date	Zero	Fiscal

PREVIOUS FISCAL NOTE(S):*

Department Date Zero Fiscal

Department	Date	Zero	Fiscal
<i>DUPF - 016-48 Commissioner</i>	<i>4/1/95</i>	✓	

APPROPRIATION -- no fiscal note

*Include fiscal notes accompanying Governor's bill

FISCAL NOTE

STATE OF ALASKA
1995 LEGISLATIVE SESSION

BILL NO. HB 287

Revision Date: _____ Dept. Affected: Transportation and Public Facilities
 Title: An Act relating to outdoor advertising on trash BRU: Office of the Commissioner
receptacles and restrictions on outdoor advertising Component: Commissioner's Office
 Sponsor: Representative Rokberg
 Requester: Representative Rokberg COMPONENT SERIAL NO. 530

Expenditures/Revenues (Thousands of Dollars)

OPERATING EXPENDITURES	FY 96	FY 97	FY 98	FY 99	FY 00	FY 01
PERSONAL SERVICES	0.0	0.0	0.0	0.0	0.0	0.0
TRAVEL						
CONTRACTUAL						
SUPPLIES						
EQUIPMENT						
LAND & STRUCTURES						
GRANTS, CLAIMS						
MISCELLANEOUS						
TOTAL OPERATING	0.0	0.0	0.0	0.0	0.0	0.0

CAPITAL EXPENDITURES						
----------------------	--	--	--	--	--	--

CHANGE IN REVENUES						
--------------------	--	--	--	--	--	--

FUND SOURCE (Thousands of Dollars)

1002 Federal Receipts						
1003 GF Match						
1004 GF	0.0	0.0	0.0	0.0	0.0	0.0
1005 GF/Program Receipts						
1006 GF/MHTIA						
Other						
TOTAL	0.0	0.0	0.0	0.0	0.0	0.0

Estimate of any current year (FY95) cost: \$ 0.0

POSITIONS

FULL-TIME						
PART-TIME						
TEMPORARY						

ANALYSIS: (Attach a separate page if necessary)

This bill would not affect the Department. As written, it would only apply to trash receptacles adjacent to bus shelters or bus benches. No fiscal impact would be expected.

Prepared by: Sam Kito III, P.E.
 Division: Commissioner's Office
 Approved by Commissioner: *Sam Kito III*
 Agency: Department of Transportation and Public Facilities

Phone: 465-3804
 Date: 3/29/95
 Date: 3/30/95

PREPARER TO PROVIDE ALL DISTRIBUTION COPIES TO GOVERNOR'S LEGISLATIVE OFFICE

For further distribution information, call the Governor's Legislative Office

ALASKA STATE LEGISLATURE

House of Representatives

COMMITTEE ASSIGNMENTS

W. S. JOHNSON
LAWRENCE S. JOHNSON, VICE CHAIR
ADMINISTRATIVE REGULATION REVIEW, VICE CHAIR
HEALTH, EDUCATION & SOCIAL SERVICES, MEMBER
ECONOMIC DEVELOPMENT, MEMBER



INTERIM
710 WEST 8TH AVENUE, SUITE 200
ANCHORAGE, AK 99501
PHONE: (907) 258-8121

SESSION
STATE CAPITOL
JUNEAU, AK 99801-1102
PHONE: (907) 465-4968
FAX: (907) 465-2040

Representative Norman Rokeberg

SPONSOR STATEMENT

HB 287 - "An Act relating to outdoor advertising on trash receptacles and restrictions on outdoor advertising."

HB 287 was introduced to allow commercial advertising on the sides of trash receptacles that are located adjacent bus shelters and bus benches located on state highways.

Currently, the Municipality of Anchorage allows advertising on trash receptacles. A number of potential locations exist for additional litter containers but they are located on state maintained highways. HB 287 would remove the prohibition.



THIS MATERIAL MAY NOT BE REPRODUCED
 IN WHOLE OR PART WITHOUT THE EXPRESS
 WRITTEN PERMISSION OF CANAD PATENT
 FENCING - COPYRIGHT 1993



Design
 Drafting and Graphics
 1000 W. 10th St.
 Anchorage, Alaska 99501

DATE	10/10/93
BY	10/10/93
SCALE	1:1
PROJECT	10/10/93
FILE NO.	10/10/93

ISOMETRIC
 TRASH RECEPTACLE
 FOR
 CANAD

10/10/93
 Eric C. Jones
 PO Box 10771
 ANCHORAGE, ALASKA 99511

NO.	DESCRIPTION	DATE



HOOD PLAN VIEW, PART 'E'

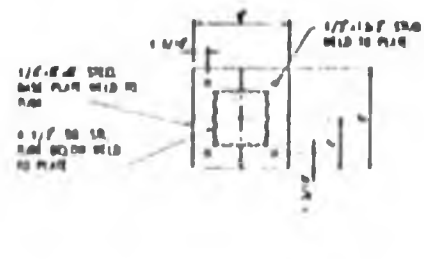

BASE & COLUMN PLAN VIEW, PART 'A'

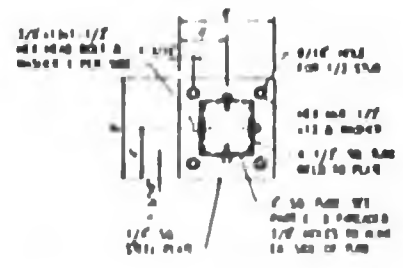

RECEPTACLE BASE-PLAN VIEW, PART 'B'

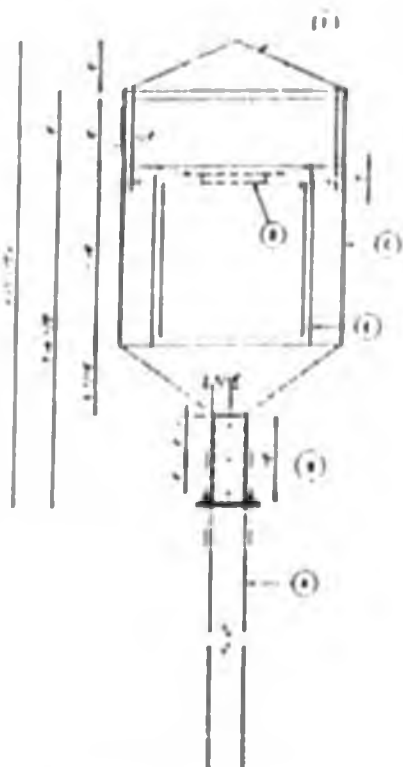

FRONT ELEVATION ASSEMBLY

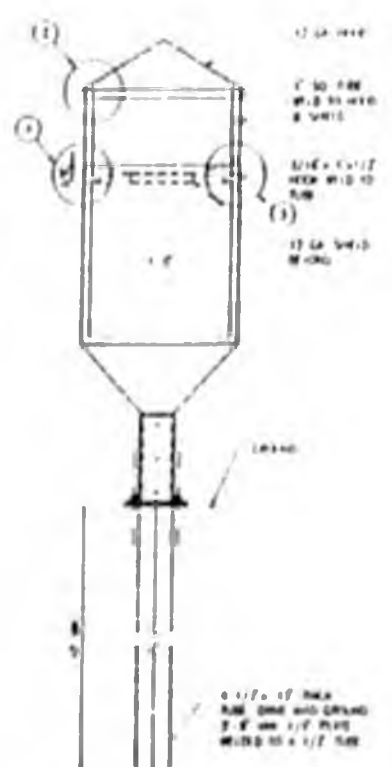

SIDE ELEVATION ASSEMBLY

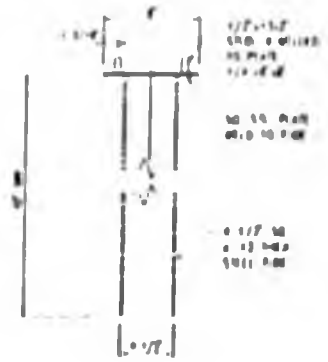

BASE & COLUMN ELEVATION PART 'A'

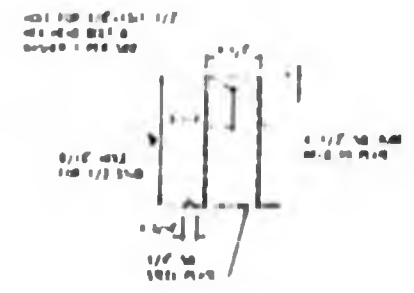

RECEPTACLE BASE-ELEVATION PART 'B'

- NOTES**
- ALL DIMS TO BE UNLESS OTHERWISE SPECIFIED
 - ALL DIMS TO BE CENTERLINE UNLESS OTHERWISE SPECIFIED
 - ALL DIMS TO BE TO THE OUTSIDE UNLESS OTHERWISE SPECIFIED
 - ALL DIMS TO BE TO THE CENTERLINE UNLESS OTHERWISE SPECIFIED
 - ALL DIMS TO BE TO THE CENTERLINE UNLESS OTHERWISE SPECIFIED

THIS MATERIAL MAY NOT BE REPRODUCED OR WHOLE OR PART WITHOUT THE EXPRESS WRITTEN PERMISSION OF CANAD PATENT PENDING - COPYRIGHT 1993



DATE	BY	CHKD

PLAN VIEW ELEVATIONS, & NOTES
TRASH RECEPTACLE
CANAD

8400 C. Street
P.O. Box 110721
MEMPHIS, TENNESSEE 38111

NO.	REV.	DATE	BY	CHKD

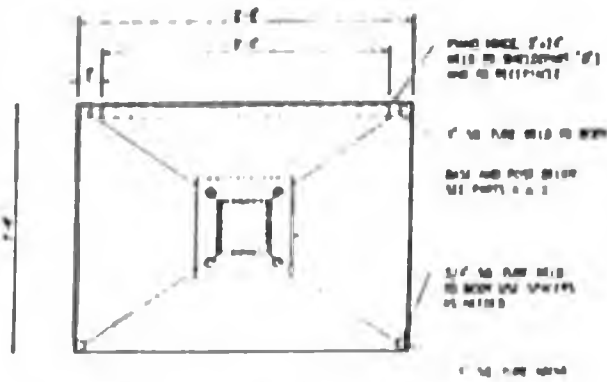

RECEPTACLE BODY-PLAN VIEW, PART C
SCALE 1/2" = 1'-0"

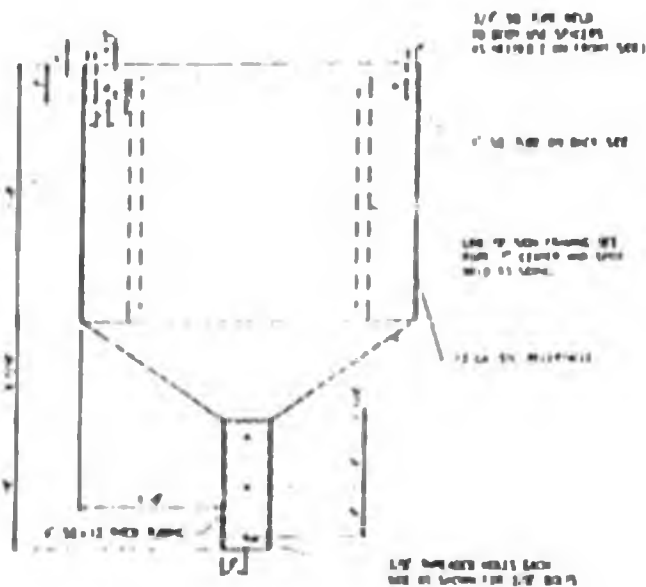

RECEPTACLE BODY-FRONT ELEV, PART C
SCALE 1/2" = 1'-0"

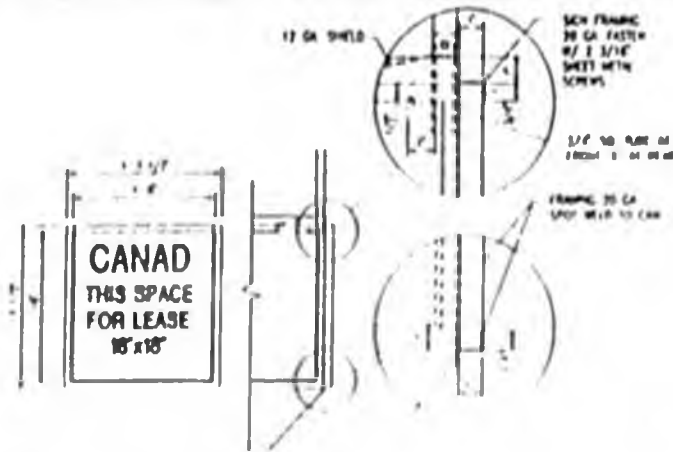

SIGN FRAMING, PART F
SCALE 1/2" = 1'-0"
PAGE 1 OF 1

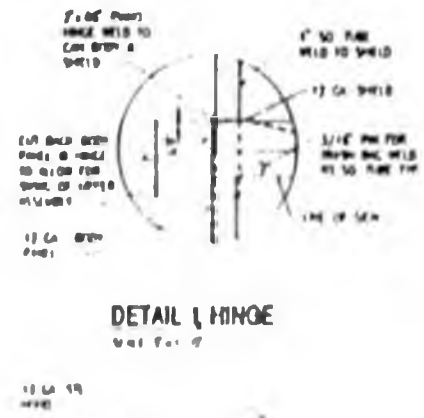

DETAIL 1, HINGE
SCALE 1/2" = 1'-0"

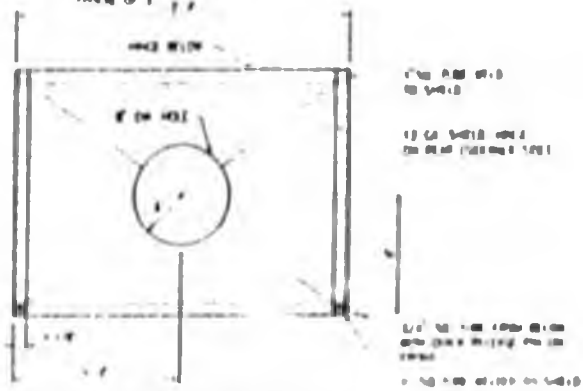

SHIELD PLAN VIEW, PART D
SCALE 1/2" = 1'-0"

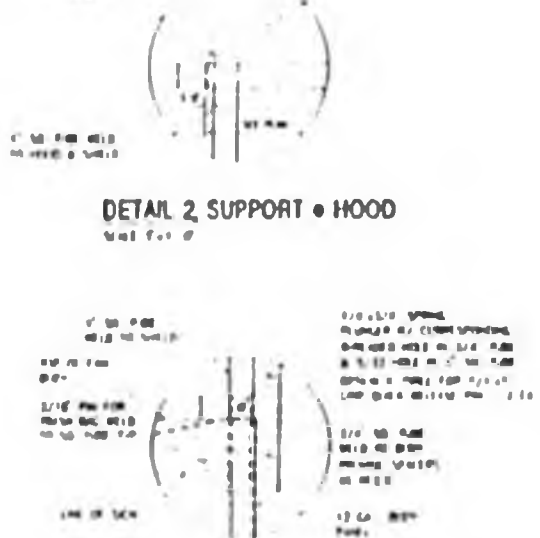

DETAIL 2, SUPPORT HOOD
SCALE 1/2" = 1'-0"

DETAIL 3, PIN SUPPORT
SCALE 1/2" = 1'-0"



SHIELD SIDE VIEW, PART D
SCALE 1/2" = 1'-0"

THIS MATERIAL MAY NOT BE REPRODUCED
IN WHOLE OR PART WITHOUT THE EXPRESS
WRITTEN PERMISSION OF CANAD PATENT
PENDING - COPYRIGHT 1993



Design
Drafting and Graphics
1000 W. 10th St.
Anchorage, Alaska 99501
Phone: 223-1111

PLANS, ELEVATIONS, DETAILS
TRASH RECEPTACLE
by
CANAD

Project No.
Date: C. 1993
P.O. Box 111721
ANCHORAGE, ALASKA 99511

REVISIONS	
NO.	DESCRIPTION

Alaska Statutes

Title 19. Highways and Ferries.

Chapter

05. Administration (§ 19 05 046)
25. Protection and Use of State Highways and Roads (§§ 19 25 010, 19 25 105, 19 25 123, 19 25 150, 19 25 200)
30. Access Roads (§§ 19 30 127, 19 30 233)
40. James Dalton Highway (§ 19 40 200)
45. Miscellaneous Provisions (§ 19 45 001)
60. Ferry Terminal Facilities (§ 19 60 030)
65. Alaska Marine Highway System (§§ 19 65 011, 19 65 025 — 19 65 100)

Chapter 05. Administration.

Article

1. Department of Transportation and Public Facilities (§ 19 05 046)

Article 1. Department of Transportation and Public Facilities.

Section

46. [Repealed]

Sec. 19 05 046. Accounting and disposition of receipts from non-state entities. [Repealed. § 25 ch 90 SLA 1991.]

Chapter 10. State Highway System.

Article 1. Designation, Marking, and Use.

Sec. 19.10.010. Dedication of land for public highways.

NOTES TO DECISIONS

Rights of owners of subservient estates as to highways built on section line easements. — A rule guaranteeing owners of subservient estates of section line easements a right of direct access to any highway which may be built on those easements would be inconsistent with the purpose of this statute, which is to provide easements on which it is relatively easy and inexpensive for the state to build highways. Compensation for loss

of direct access would have the opposite effect: it would greatly increase the cost of constructing controlled access highways on section line easements. 0 938 Acres v. State 142 P.2d 96; Alaska 1946; modified on other grounds 169 P.2d 99; Alaska 1949.

Compensation owed when landowner deprived of reasonable access. — When the state condemns the fee interest in land in which it owns a section line

ement, it owes no compensation for the loss of access to the easement, since no preexisting right was taken. Only if the taking deprives the landowner of reasonable access to the network of streets to which it previously had access would the state owe compensation. 096A Acres v. State, 762 P.2d 96 (Alaska 1988), modified on other grounds, 769 P.2d 990 (Alaska 1989).

The question whether a condemnee's remaining access to a condemned section line easement is reasonable is plainly a matter of degree. It involves an ad hoc analysis of the facts that actually or potentially lead to the property after the condemnation, to determine if they are suitable for the traffic that would likely go to the property. The analysis necessarily involves an examination of the potential use of the property. 096A Acres v. State, 762 P.2d 96 (Alaska 1988), modified

on other grounds, 769 P.2d 990 (Alaska 1989).

Nominal rather than actual damages are appropriate for condemnation of the fee underlying a highway right-of-way unless there is a showing of special value. 096B Acres v. State, 762 P.2d 96 (Alaska 1988), modified on other grounds, 769 P.2d 990 (Alaska 1989).

No duty to compensate for condemnee's increased burden of subdividing. — Even though section line easement condemnments may, as a result of the condemnation, have to dedicate more land for rights-of-way in subdividing their property than they would have in the absence of the condemnation, the state is not required to compensate them for that increased burden. 096A Acres v. State, 762 P.2d 96 (Alaska 1988), modified on other grounds, 769 P.2d 990 (Alaska 1989).

Sec. 19.10.085. Naming of a highway.

Cross references. For statutory provisions naming certain highways, see AS 19.40.

Chapter 25. Protection and Use of State Highways and Roads.

Article

1. Utilities in Highways (§ 19.25.010)
2. Outdoor Advertising (§§ 19.25.105, 19.25.123, 19.25.150)
3. Encroachments in Highways (§ 19.25.200)

Article 1. Utilities in Highways.

Section

10. Use of rights-of-way for utilities

Sec. 19.25.010. Use of rights-of-way for utilities. A utility facility may be constructed, placed, or maintained across, along, over, under, or within a state right-of-way only in accordance with regulations adopted by the department and if authorized by a written permit issued by the department. The department may charge a fee for a permit issued under this section. AS 8 art VII title II ch 152 S.L.A. 1957, am 3-3 ch 106 S.L.A. 1977, am 4-36 ch 36 S.L.A. 1990.

Effect of amendments. The 1991 amendment, effective May 12, 1990, added the second sentence.

Article 2. Outdoor Advertising.

Section

105. Limitations of outdoor advertising signs, displays and devices
123. Fairbanks — Seward peninsula

Section

- transportation and utility corridor
150. Unlawful advertising

Sec. 19.25.105. Limitations of outdoor advertising signs, displays and devices. (a) Outdoor advertising may not be erected or maintained within 660 feet of the nearest edge of the right-of-way and visible from the main-traveled way of the interstate, primary, or secondary highways in this state except the following:

(1) directional and other official signs and notices which include, but are not limited to, signs and notices pertaining to natural wonders, scenic and historic attractions, which are required or authorized by law, and which shall conform to federal standards for interstate and primary systems;

(2) signs, displays, and devices advertising the sale or lease of property upon which they are located or advertising activities conducted on the property;

(3) signs determined by the state, subject to concurrence of the United States Department of Transportation, to be landmark signs, including signs on farm structures, or natural surfaces, of historic or artistic significance, the preservation of which would be consistent with the provisions of this chapter;

(4) directional signs and notices pertaining to schools;

(5) advertising on bus benches or bus shelters if the state determines that the advertising conforms to local, state, and federal standards for interstate and primary highway systems.

(b) *[Repealed, § 21 ch 94 S.L.A. 1980]*

(c) Outdoor advertising may not be erected or maintained beyond 660 feet of the nearest edge of the right-of-way of the main-traveled way of the interstate, primary, or secondary highways in this state with the purpose of their message being read from that travel way except those outdoor advertising signs, displays, or devices allowed under (a) of this section.

(d) Outdoor advertising may not be erected or maintained within the right-of-way of an interstate, primary, or secondary highway except that outdoor advertising is allowed on bus benches and bus shelters located within the right-of-way under the authority of a permit issued under AS 19.25.200, if the bus benches or bus shelters are located within a borough or unified municipality and the buses that stop at that location operate during the entire year. AS 3 ch 155 S.L.A. 1970, am 4-1, 2 ch 195 S.L.A. 1975, am 3-1 ch 30 S.L.A. 1980, am 3-21 ch 94 S.L.A. 1980, am 4-1 ch 6 S.L.A. 1987, am 3-2 ch 158 S.L.A. 1980.

CANAD

APR 01 1995

April 1, 1995

Representative Norman Rokeberg
State Capitol
Juneau, Alaska 99801-1182

Dear Norm,

I would like to thank you and your staff for the support and interest you show in your district. The public meetings held March 11th received a good turn out; all we need now is for the general public to understand the steps that need to be taken to bring a wild bull under control.

In regard to House Bill NO.287, I would like to thank you and a special thanks to Shirley Armstrong for being persistent during such a busy period. I will make myself available on April 7th at 1:00 pm to participate in the teleconference to testify in support of this bill.

If I can be of any assistance to you please let me know and I will do my best to oblige.

Sincerely,

Race G. Jones

Race G. Jones
CANAD/President

Municipality
of
Anchorage



1000 E. 12th Ave.
Anchorage, Alaska 99501-1000
Telephone: (907) 543-4000
Fax: (907) 543-4001
Rick Mysterom Mayor

OFFICE OF THE MAYOR

December 2, 1994

Race G. Jones
P. O. Box 111725
Anchorage, AK 99511

Dear Mr. Jones:

I believe that a beautiful, clean city, will be a great asset in our community's strategy to increase economic development and reduce crime and violence.

It is my vision to have Anchorage recognized as the city of lights and flowers and it will take the enthusiasm and cooperation of many organizations to bring this about. I am confident that a beautification program will give our citizens a sense of well-being and pride that will improve the quality of life for all concerned.

Thank you for sharing information with me on your plan for litter prevention. I wish you all the best.

Sincerely,

Rick Mysterom
Mayor

WALTER J. HICKEL, GOVERNOR

DEPARTMENT OF COMMERCE AND
ECONOMIC DEVELOPMENT

DIVISION OF ECONOMIC DEVELOPMENT

1601 C STREET, SUITE 724
ANCHORAGE, ALASKA 99503-5337
PHONE (907) 563-2165
FAX (907) 562-0048

March 14, 1994

Mr. Race G. Jones
PO Box 111725
Anchorage, AK 99511

Dear Mr. Jones:

Thank you for sending me your new brochure and pictures of your litter receptacles. It looks as if you are making some real progress with your business plans. I agree that the phrase "support litter free streets" is a motto we should all get behind, whether public or private. The trash and garbage on our public streets is a disgrace.

The department has a policy of not endorsing an individual product, and I am sure you can understand why. I have worked with you in the development of the CANAD litter receptacles, however, and I think it is a quality product. With your permission we will add your name to our list of goods and services that we make available in response to inquiries.

I have appreciated the opportunity of working with you on this product and I wish you continued good luck.

Yours truly

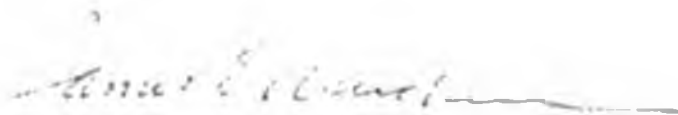

James E Wiedeman
Development Officer

DEPARTMENT OF TRANSPORTATION
AND PUBLIC FACILITIES
OFFICE OF THE COMMISSIONER

WALTER J. HICKEL, GOVERNOR

3132 CHANNEL DRIVE
JUNEAU, ALASKA 99801-7898

TEXT : 907 465-3652
FAX : 907 586-8365
PHONE : 907 465-3900

November 14, 1994

Mr. Race G. Jones, President
CANAD
P.O. Box 111725
Anchorage, AK 99511

Dear Mr. Jones:

Thank you for your letter of October 21, 1994. I had my staff research the conditions surrounding your request to install litter receptacles in our right-of-way. Due to the fact that both Alaska Statute 19.25.110 and Alaska Administrative Code 20.010 only allow advertising on bus benches and bus shelters, this Department does not have statutory authority to approve your request.

The Department recognizes the benefit that the litter receptacles could offer. However, until the Alaska Statutes are changed our hands are tied.

I am sorry I could not have been more helpful in this matter.

Sincerely,

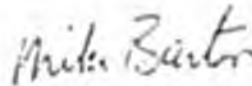

Michael A. Barton
Commissioner

Municipality
of
Anchorage



5800 E. 22nd Avenue
Anchorage, Alaska 99516
Telephone (907) 343-3333
Fax (907) 343-3333

ANCHORAGE ASSEMBLY
Pat Abney
Assembly Member

March 8, 1994

Race G. Jones, General Manager
CANAD
P.O. Box 111725
Anchorage, Alaska 99511-1725

Dear Race:

Thanks for taking the time to meet with me last week in regards to your proposal to address the problem of litter on our city streets. I think your idea of starting this program in the downtown business area is innovative and will prove to be well-received.

You mentioned that you were seeking assistance with the installation and service of litter receptacles and working on draft revisions to the right of way ordinance. It sounds as if you are doing everything to work with the appropriate officials to get this program underway.

I look forward to hearing from the Urban Design Commission regarding their recommendations and suggestions related to your proposal.

Let me know if I can be of further assistance. You may consider this letter my statement of support for the litter-free streets program in Anchorage.

Sincerely,

Pat Abney
Assembly Vice-Chair

MUNICIPALITY
OF
Anchorage



111195002 037 24 11 94

Mark Begich, Vice Chair
Anchorage Assembly
P.O. Box 201027
Anchorage, Alaska 99520

March 1, 1994

Race G. Jones, General Manager
CANAD
P.O. Box 111725
Anchorage, Alaska 99511-17125

Dear Race:

Thanks for a most informative letter about your innovative program to address the problem of litter on our city streets. I think the idea of starting your program in the downtown business district is great! I am very interested in the concept and totally support your proposal.

You mentioned that you were seeking assistance with the installation and service of litter receptacles and working on draft revisions to the right of way ordinance. Let me know how I can help.

I look forward to hearing from you.

Sincerely,

Mark Begich
Assembly

HB

411

FISCAL NOTE

STATE OF ALASKA
1996 LEGISLATIVE SESSION

BILL NO. HB 411 | _____

Revision Date: 1/12/96 Dept. Affected: DOT&PF
 Title: "An Act naming Mountain View Road in Gustavus." BRU: Southeast Region
 Component: Maintenance and Operations
 Sponsor: Mackie
 Requester: _____ COMPONENT SERIAL NO. _____

Expenditures/Revenues

(Thousands of Dollars)

OPERATING EXPENDITURES	FY 97	FY 98	FY 99	FY 00	FY 01	FY 02
PERSONAL SERVICES						
TRAVEL						
CONTRACTUAL						
SUPPLIES						
EQUIPMENT						
LAND & STRUCTURES						
GRANTS, CLAIMS						
MISCELLANEOUS						
TOTAL OPERATING	0.0	0.0	0.0	0.0	0.0	0.0
CAPITAL EXPENDITURES	0.0	0.0	0.0	0.0	0.0	0.0
CHANGE IN REVENUES ()	0.0	0.0	0.0	0.0	0.0	0.0

FUND SOURCE

(Thousands of Dollars)

1002 Federal Receipts						
1003 GF Match						
1004 GF						
1005 GF/Program Receipts						
1006 GF/MHTIA						
Other						
TOTAL	0.0	0.0	0.0	0.0	0.0	0.0

Estimate of any current year (FY96) cost: \$ 0.0

POSITIONS

FULL-TIME	0	0	0	0	0	0
PART-TIME	0	0	0	0	0	0
TEMPORARY	0	0	0	0	0	0

ANALYSIS: (Attach a separate page if necessary)

The cost of two signs to display the new name for this Gustavus highway segment can be added to our current roadway reconditioning project there, so a zero fiscal note is in order.

Prepared by: Bruce Freitag, Loren Rasmussen, P.E., Acting Director Phone: 485-2960
 Division: Engineering and Operations Date: 1/23/96
 Approved by: Joseph L. Perkins Date: 1/23/96
 Agency: Department of Transportation and Public Facilities

PREPARED TO PROVIDE ALL DISTRIBUTION COPIES TO GOVERNOR'S LEGISLATIVE OFFICE

For further distribution information, call the Governor's Legislative Office

Alaska State Legislature

ALASKA STATE CAPITOL
JUNEAU, ALASKA 99801-1152
(907) 465-4925

REPRESENTATIVE
JERRY MACKIE



P.O. BOX 791
CRAIG, ALASKA 99921
(907) 926-3008 OFFICE
(907) 826-2910 HOME

House of Representatives

Memorandum

Date: March 19, 1996

To: Senator Steve Rieger, Chair **STEVE**
Senate Transportation Committee

From: Representative Jerry Mackie **Jerry**
Alaska State Legislature

Subject: Request to schedule - HB 411 - "An Act naming Mountain View Road in Gustavus."

I would greatly appreciate your consideration in scheduling HB 411 for a hearing at your earliest convenient opportunity. Students and adults in Gustavus have received a positive view and an informational view of the legislative process and this issue seems to have given everyone within the community a common purpose.

Alaska Statute Sec. 29.10.085 (attached) requires that highway names be given through legislation. Based on the my contacts with the community and the petition which I received in my office, it's obvious that if the community of Gustavus could have done this locally, the sign would read "Mountain View Road" today.

Thanks for your consideration. Please call me if you have any questions.

(4) that speed at which safe and prudent drivers could pass through the speed zone; and

(5) the effectiveness of local enforcement of the speed zone.

(b) In determining safe speed limits and safe speed zones within a municipality, the department shall consult with that municipality. In determining safe speed limits and safe speed zones on highways and other roadways under its jurisdiction, the department shall also consult with community councils or other community organizations in the affected area if the community councils or other community organizations request in writing to participate in the determination. The department shall provide notice and opportunity for a hearing before establishing a speed limit or speed zone other than as recommended by a municipality, community council or other community organization. (§ 2 ch 23 SLA 1986)

Sec. 19.10.080. Designation of through highways. The department may designate through highways by erecting stop signs at the entrances to them. (§ 7 art III title II ch 152 SLA 1957)

Sec. 19.10.085. Naming of a highway. (a) A highway constructed by the department under AS 19.05 — AS 19.40 may be given a name only by law.

(b) This section does not apply to

(1) a road constructed by a municipality under a grant authorized by AS 19.05 — AS 19.40;

(2) local service roads and trails. (§ 1 ch 4 SLA 1981)

Revisor's notes. — Enacted as AS 19.05.150. Renumbered in 1981.

Sec. 19.10.090. Erection and maintenance of guard rails. The department may erect and maintain guard rails, stretch wires and other devices, on highways. (§ 8 art III title II ch 152 SLA 1957)

Sec. 19.10.100. Closing highways. When it is necessary to exclude traffic from any portion of a highway, the department may close that portion of the highway by posting in a conspicuous manner, at each end of the portion closed, suitable signs warning the public that the road is closed under authority of law, and by erecting suitable obstructions. (§ 8 art IV title II ch 152 SLA 1957)

Gustavus Community Association



Post Office Box 62
Gustavus, Alaska 99826

Representative Jerry Mackie
Alaska State Legislature
Juneau, Alaska 99801-1182

January 21, 1996

RE: HB411- "An Act naming Mountain View Road in Gustavus."

Dear Representative Mackie:

On January 11th the Gustavus Community Association held their monthly meeting. One of the agenda items was the petition and your bill concerning Mountain View Road.

This letter serves to advise you that the GCA members voted unanimously to support the petition and your legislation to officially name this road "Mountain View Road."

Incidentally, it was pointed out the spelling of "Goodriver Road" as is contained in the bill should be changed to "Good River Road."

On behalf of the Gustavus Community Association, thanks for your attention to this matter.

Sincerely,

Kathy Leary
GCA Administrator

MOUNTAIN VIEW ROAD

HISTORY: IN THE LATE 1950'S EUGENE & ANNE CHASE ACQUIRED THEIR HOMESTEAD LAND WHICH CONTAINED 160 ACRES PLUS 50 ACRES FROM ARCHIE CHASE. THE LAND WAS LOCATED ON BOTH SIDES OF THE MAIN ROAD NORTH OF GOOD RIVER CORNER UP TO WHAT IS NOW KNOWN AS TONG ROAD. THE CHASES AT THAT TIME NAMED THE ROAD "MOUNTAIN VIEW ROAD". OVER THE YEARS THIS ROAD HAS BEEN CALLED "GUSTAVUS MAIN ROAD", "PARK SERVICE ROAD", "MAIN ROAD", AND VARIOUS OTHER NAMES.

THEREFORE: WE THE UNDERSIGNED RESIDENTS OF GUSTAVUS WOULD REQUEST THAT THIS MAIN HIGHWAY BE OFFICIALLY NAMED "MOUNTAIN VIEW ROAD"

PRINTED NAME	SIGNATURE	ADDRESS
ck- Sylvia Pedersen	<i>Sylvia Pedersen</i>	Spruce Lane #2 016 Gustavus, Ak 99806
Michael Pedersen	<i>Michael Pedersen</i>	" "
Gloria Chase	<i>Gloria Chase</i>	Mountain View Road GUST. AK
JON TRAMBUSH	<i>Jon Trambush</i>	40 Long Rd
BOB CHASE	<i>Bob Chase</i>	SPRUCE LANE #5 GUSTAVUS, AK
MICHAEL CRAFT	<i>Michael Craft</i>	Mountain View Farm Gustavus, Alaska
Jean Scott	<i>Jean Scott</i>	Milk 3 Park Road Gustavus, AK 99806
Greg Strevler	<i>Greg Strevler</i>	1/2 mile Spruce Lane Box 44 Gustavus Ak
Ludie Drake	<i>Ludie Drake</i>	Box 799 #4 Spruce Lane Gustavus, Ak 99806
DON CHASE	<i>Don Chase</i>	Gustavus, Ak 99806

MOUNTAIN VIEW ROAD

HISTORY. IN THE LATE 1950'S EUGENE & ANNE CHASE ACQUIRED THEIR HOMESTEAD LAND WHICH CONTAINED 160 ACRES PLUS 50 ACRES FROM ARCHIE CHASE. THE LAND WAS LOCATED ON BOTH SIDES OF THE MAIN ROAD NORTH OF GOOD RIVER CORNER UP TO WHAT IS NOW KNOWN AS TONG ROAD. THE CHASES AT THAT TIME NAMED THE ROAD "MOUNTAIN VIEW ROAD". OVER THE YEARS THIS ROAD HAS BEEN CALLED "GUSTAVUS MAIN ROAD", "PARK SERVICE ROAD", "MAIN ROAD", AND VARIOUS OTHER NAMES.

THEREFORE: WE THE UNDERSIGNED RESIDENTS OF GUSTAVUS WOULD REQUEST THAT THIS MAIN HIGHWAY BE OFFICIALLY NAMED "MOUNTAIN VIEW ROAD"

PRINTED NAME	SIGNATURE	ADDRESS
Allen C. Trump	Allen C. Trump	P.O. Box 222 GUSTAVUS AK 99802
Maibyn D. Trump	Maibyn Trump	P.O. Box 222 GUSTAVUS AK 99802
Tom Nash	Tom Nash	Box AK 99804
Chris Spate (CHRIS SPATE)	Chris Spate	P.O. Box 103
Marion Farley	Marion Farley	Box 182 Gustavus
Denise L. Healey	Denise Healey	P.O. Box 10 GUSTAVUS
Kathleen Phelan	Kathleen Phelan	P.O. Box 4 GUSTAVUS
James R. Healey	James Healey	Box 10 GUSTAVUS AK 99802
Kathy Smeuler	Kathy Smeuler	Box 155 GUS 99802
Sharon Ann	Sharon Ann	Box 336 GUS AK 99802
JOE SARGENT	Joe Sargent	P.O. Box 27 GUS AK 99802
KIM NEY		32
Paul Bales	Paul Bales	155 GUS
Jamie Ojilvy	Jamie Ojilvy	106 GUS
G.F. Chamberlain		220 GUS

MOUNTAIN VIEW ROAD

HISTORY: IN THE LATE 1950'S EUGENE & ANNE CHASE ACQUIRED THEIR HOMESTEAD LAND WHICH CONTAINED 160 ACRES PLUS 50 ACRES FROM ARCHIE CHASE. THE LAND WAS LOCATED ON BOTH SIDES OF THE MAIN ROAD NORTH OF GOOD RIVER CORNER UP TO WHAT IS NOW KNOWN AS TONG ROAD. THE CHASES AT THAT TIME NAMED THE ROAD "MOUNTAIN VIEW ROAD". OVER THE YEARS THIS ROAD HAS BEEN CALLED "GUSTAVUS MAIN ROAD", "PARK SERVICE ROAD", "MAIN ROAD", AND VARIOUS OTHER NAMES.

THEREFORE: WE THE UNDERSIGNED RESIDENTS OF GUSTAVUS WOULD REQUEST THAT THIS MAIN HIGHWAY BE OFFICIALLY NAMED "MOUNTAIN VIEW ROAD"

PRINTED NAME	SIGNATURE	ADDRESS
MARIE BERRY	MARIE BERRY	105, GUSTAVUS
JUDITH CHALLONHEAD	JUDITH CHALLONHEAD	25 PARK DR.
FANN M BAUER	FANN M BAUER	BARTISTONE
L. VANDERZANDER	L. VANDERZANDER	GUSTAVUS
PAUL PAUL NBERG	PAUL NBERG	PO 143
ED BOND	ED BOND	223 GUSTAVUS
MAURENE MOORE	MAURENE MOORE	Box 228
Katy White	Katy White	Box 247
Lozée Archambault	Lozée Archambault	Box 75
Martha V Romeo	MARIE V ROMEO	Box 284
Lynne Morrow	Lynne Morrow	Box 216
Heidi Robichaud	Heidi Robichaud	Box 116
JOHN V. SPITE	JOHN V. SPITE	Box 184
DANIEL MURPHY	DANIEL MURPHY	Box 203
		Box 63

MOUNTAIN VIEW ROAD

HISTORY: IN THE LATE 1950'S EUGENE & ANNE CHASE ACQUIRED THEIR HOMESTEAD LAND WHICH CONTAINED 160 ACRES PLUS 50 ACRES FROM ARCHIE CHASE. THE LAND WAS LOCATED ON BOTH SIDES OF THE MAIN ROAD NORTH OF GOOD RIVER CORNER UP TO WHAT IS NOW KNOWN AS TONG ROAD. THE CHASES AT THAT TIME NAMED THE ROAD "MOUNTAIN VIEW ROAD". OVER THE YEARS THIS ROAD HAS BEEN CALLED "GUSTAVUS MAIN ROAD", "PARK SERVICE ROAD", "MAIN ROAD", AND VARIOUS OTHER NAMES.

THEREFORE, WE THE UNDERSIGNED RESIDENTS OF GUSTAVUS WOULD REQUEST THAT THIS MAIN HIGHWAY BE OFFICIALLY NAMED "MOUNTAIN VIEW ROAD"

PRINTED NAME	SIGNATURE	ADDRESS
Marilyn Jackson	<i>Marilyn Jackson</i>	Box 195 Gustavus
Becky Walker	<i>Becky Walker</i>	Box 311 99826 Gustavus
LAURA LOBI	<i>Laura Lobi</i>	Box 23 GUSTAVUS 9946
JOHN SCOTT	<i>John W Scott</i>	Box 254 99826
Judith Bon	<i>Judith Bon</i>	Box 281 99826
DAN RINNER	<i>Dan Rinner</i>	Box 212 99826
PEDR TURNER	<i>Pedr Turner</i>	PO 217 99826
CHAR DAHREN	<i>Char Dahren</i>	PO BOX 217 99826
KARLA TEDDSEN	<i>Karla Teddsen</i>	PO Box 153 Gustavus Gustavus 99826
Kate Boesser	<i>Kate Boesser</i>	Box 47, Dock Rd. 99826
Aaron Bohlke	<i>Aaron V Bohlke</i>	PO Box 324
Paul Byers	<i>Paul Byers</i>	PO Box 324
Kathy Cozby	<i>Kathy Cozby</i>	PO Box 124
Bruce McDonagh	<i>Bruce McDonagh</i>	Box 260
Philip Riddle	<i>Philip Riddle</i>	Box 216 Gustavus

MOUNTAIN VIEW ROAD

HISTORY: IN THE LATE 1950'S EUGENE & ANNE CHASE ACQUIRED THEIR HOMESTEAD LAND WHICH CONTAINED 160 ACRES PLUS 50 ACRES FROM ARCHIE CHASE. THE LAND WAS LOCATED ON BOTH SIDES OF THE MAIN ROAD NORTH OF GOOD RIVER CORNER UP TO WHAT IS NOW KNOWN AS TONG ROAD. THE CHASES AT THAT TIME NAMED THE ROAD "MOUNTAIN VIEW ROAD". OVER THE YEARS THIS ROAD HAS BEEN CALLED "GUSTAVUS MAIN ROAD", "PARK SERVICE ROAD", "MAIN ROAD", AND VARIOUS OTHER NAMES.

THEREFORE, WE THE UNDERSIGNED RESIDENTS OF GUSTAVUS WOULD REQUEST THAT THIS MAIN HIGHWAY BE OFFICIALLY NAMED "MOUNTAIN VIEW ROAD"

PRINTED NAME	SIGNATURE	ADDRESS
Diana Berry	<i>Diana Berry</i>	P.O. Box 105 Gustavus, AK 99826
James Kearns	<i>James Kearns</i>	Box 148 Gustavus, AK 99826
JOHN SHERRENS	<i>John Sherrens</i>	Box 161 GUSTAVUS AK 99826
<i>Amymones</i>	<i>Amee Youmans</i>	Box 40 GUSTAVUS AK 99826
ROBERT L. MILLS	<i>Robert L. Mills</i>	Box 64 GUSTAVUS, AK
Chris Smith	<i>Chris Smith</i>	Box 93 Gustavus
<i>Glen R. Parker</i>	<i>Glen R. Parker</i>	Box 52 Gustavus
<i>Kara Berg</i>	<i>Kara Berg</i>	Box 154 Gustavus, AK 99826
<i>Michael J. Nisco</i>	<i>Michael J. Nisco</i>	Box 81 Gustavus AK 99826
<i>Gene Hoppen</i>	<i>Gene Hoppen</i>	Box 197 Gustavus, AK 99826
CHRISTY OLSEN	<i>Christy Olsen</i>	Box 244 Gustavus, AK 99826
Scott Olsen	<i>Scott Olsen</i>	" " "
Kenneth L. Klawunder	<i>Kenneth L. Klawunder</i>	Box 156 Gustavus, AK 99826
Dianne S. Klawunder	<i>Dianne S. Klawunder</i>	Box 156 Gustavus, AK 99826
Cinda L. Morgan	<i>Cinda L. Morgan</i>	Box 191 Gustavus, AK 99826

MOUNTAIN VIEW ROAD

HISTORY: IN THE LATE 1950'S EUGENE & ANNE CHASE ACQUIRED THEIR HOMESTEAD LAND WHICH CONTAINED 160 ACRES PLUS 50 ACRES FROM ARCHIE CHASE. THE LAND WAS LOCATED ON BOTH SIDES OF THE MAIN ROAD NORTH OF GOOD RIVER CORNER UP TO WHAT IS NOW KNOWN AS TONG ROAD. THE CHASES AT THAT TIME NAMED THE ROAD "MOUNTAIN VIEW ROAD". OVER THE YEARS THIS ROAD HAS BEEN CALLED "GUSTAVUS MAIN ROAD", "PARK SERVICE ROAD", "MAIN ROAD", AND VARIOUS OTHER NAMES.

THEREFORE: WE THE UNDERSIGNED RESIDENTS OF GUSTAVUS WOULD REQUEST THAT THIS MAIN HIGHWAY BE OFFICIALLY NAMED "MOUNTAIN VIEW ROAD"

PRINTED NAME	SIGNATURE	ADDRESS
LEILANI JOHNSON	Leilani Johnson	71 TONG RD Box 288, Gustavus
BRUCE SHINGLEDECKER	Bruce Shingledecker	49 TONG RD GUS.
FLOYD M. BERTON	FLOYD M. BERTON	7 Chase Drive
GARRIE L. WALKER	GARRIE L. WALKER	Box 319
DAVID WALKER	DAVID WALKER	Box 318
WILLIAM L. WHITE	William L. White	Box 84
BETTE J. WHITE	BETTE J. WHITE	Box 84
JAMIE F. COBY	JAMIE F. COBY	Box 2
GARY EVANS	GARY EVANS	Box 327
SHELLY A. WEBB	SHELLY A. WEBB	Box 58
MARY E. SUTTON OPP	MARY E. SUTTON OPP	Box 92
JAMES NICKIN	JAMES NICKIN	Box 119
STEVE WILSON	STEVE WILSON	P.O. Box 16
CONNIE MILLS	CONNIE MILLS	BOX 151
LYNN SAVONEN	LYNN SAVONEN	Box 172

MOUNTAIN VIEW ROAD

HISTORY: IN THE LATE 1950'S EUGENE & ANNE CHASE ACQUIRED THEIR HOMESTEAD LAND WHICH CONTAINED 160 ACRES PLUS 50 ACRES FROM ARCHIE CHASE. THE LAND WAS LOCATED ON BOTH SIDES OF THE MAIN ROAD NORTH OF GOOD RIVER CORNER UP TO WHAT IS NOW KNOWN AS TONG ROAD. THE CHASES AT THAT TIME NAMED THE ROAD "MOUNTAIN VIEW ROAD". OVER THE YEARS THIS ROAD HAS BEEN CALLED "GUSTAVUS MAIN ROAD", "PARK SERVICE ROAD", "MAIN ROAD", AND VARIOUS OTHER NAMES.

THEREFORE: WE THE UNDERSIGNED RESIDENTS OF GUSTAVUS WOULD REQUEST THAT THIS MAIN HIGHWAY BE OFFICIALLY NAMED "MOUNTAIN VIEW ROAD"

PRINTED NAME

SIGNATURE

ADDRESS

Dena Mathin Dena Mathin Box 22
Gustavus

Tania Keim Tania Keim Box 315
Gustavus

DAVID MARTINSON David Martinson Box 173
GUSTAVUS

Dorothy O'Hara Dorothy O'Hara Box 18 Local

Carol Dejka Carol Dejka Bx 168 local

Luis Belorai Luis Belorai Bx 339 local

Chuck Rice C. Rice Box 116

Marianne Eggen Marianne Eggen Box 260 local

W. J. H. H. W. J. H. H. Box 32

LESLIE C. SIKSTAD Box 80 GUSTAVUS

MICHELLE PEDERSEN Michelle Pedersen

Art Hayes Art Hayes R. 165T

ALBERT MANCHESTER Albert Manchester Box 225

Rhea Harper Rhea Harper P.O. 214

Thorne Inboden Thorne Inboden P.O. 214

not
JUN 18

January 24, 1996

LINDA Q Hayes
PO Box 1

Gustavus, Alaska 99826

Representative Jerry Mackie
Alaska State Legislature
House of Representatives

Representative Mackie,

Thank you for your support of
House Bill 1111 "AN ACT NAMING"
Mountain View Road in Gustavus.

Please add our names
in support of this Bill.

Thank you for your interest
and support of our community.

Sincerely,

Linda Q Hayes
Arthur D Hayes



Phone 586-3539 (work)
Phone 586-1723 (home)
3251 Foster Ave.
Juneau, AK 99801
Jan. 23, 1996

Mr. Jerry Mackie, Rep.

Dear Jerry,

Regarding changing the road name in Gustavus, to Mountain View Road.

My deceased husband Eugene S. Chase and I used this name ever since we were proving up on our 160 acre homestead. We even named our farm Mountain View Farm. It has many memories and sounds good. I wish I could find a picture of it. I've looked for hours. I know I do have some.

If at all possible, please preserve that name.

I understand it would be from the Good River corner to the Park Road corner. That's all that is needed.

Thank You Very Much Jerry,

Sincerely,

Anne L. Gregg

Anne L. Gregg

P.O. Box 200
Gustavus, AK 99826

23 January 1996

Representative Jerry Mackey,

Our names do not appear on the petition previously submitted to the Department of Transportation requesting that the road in Gustavus be named Mountain View Road. We would, however, like to go on record as supporting that request.

Please make this known at the hearing to be held on this matter.

Thank you.

Sincerely,

Sally Lesh

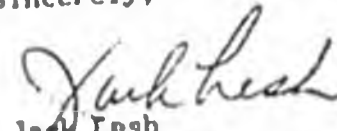
Jack Lesh

Jan. 22-96

Dear Rep Mackie,

I'm writing you concerning the "main" road that goes from Good River corner to Park boundary corner. I'm obviously in support of making a law to have the name legally recognized as "Mountain View Road".

Part of this road used to run through my parents (Eugene + Anne Chase) homesteaded land.

They at that time always called it "Mountain View Road". My father was raised between here + Juneau and was Gustavus Postmaster for 34 yrs. until his retirement in '87. He passed away here 2 yrs. ago. My mother was born in Juneau but otherwise lived here all of her life. She + my Dad lived on their homestead for nearly 40 yrs. My mom is currently living in Juneau, however she still refers to this as home + the road as Mountain View Rd. She is very happy that we are pursuing getting this change legal. I never knew that there was any "legal" name on this road until writing to someone's office - no one has ever referred to the road in question as Gustavus Airport Rd. as E.P.T. claims it is called. Thank you for your help (+ Jennies) in this matter.

5 0 0 0 0 0

HB

498

FISCAL NOTE

Revision Date: 2/12/96 Department Affected: DOT&PF
 Title: Naming the Berte Cao Bridge in Valdez. BRU.
 (Currently known as the Mineral Creek Bridge - W. Egna Drive)
 Sponsor: Transportation, State Affairs Component:
 Requestor: Component Serial Number:

EXPENDITURES/REVENUES: (Thousands of Dollars)

OPERATING	FY97	FY98	FY99	FY00	FY01	FY02
PERSONAL SERVICES	0	0	0	0	0	0
TRAVEL	0	0	0	0	0	0
CONTRACTUAL	0	0	0	0	0	0
SUPPLIES	0	0	0	0	0	0
EQUIPMENT	0	0	0	0	0	0
LAND & STRUCTURES	0	0	0	0	0	0
GRANTS, CLAIMS	0	0	0	0	0	0
MISCELLANEOUS	0	0	0	0	0	0
TOTAL OPERATING:	0	0	0	0	0	0

CAPITAL	0	0	0	0	0	0
---------	---	---	---	---	---	---

REVENUE FUND SOURCE	0	0	0	0	0	0
---------------------	---	---	---	---	---	---

FUNDING: (Thousands of Dollars)

1002 FEDERAL RECEIPTS	0	0	0	0	0	0
1003 GF MATCH	0	0	0	0	0	0
1004 GF	0	0	0	0	0	0
1005 GF/PROGRAM RECEIPTS	0	0	0	0	0	0
1006 GF/MHTLA	0	0	0	0	0	0
OTHER	0	0	0	0	0	0
TOTAL FUNDING:	0	0	0	0	0	0

POSITIONS (NONE REQ'D)

FULL-TIME	0	0	0	0	0	0
PART-TIME	0	0	0	0	0	0
TEMPORARY	0	0	0	0	0	0

Estimate of current year (FY96) impact: \$0

ANALYSIS: (Attach a separate page if necessary)

The only anticipated expense of this change will be the purchase and installation of two new signs at the bridge site (estimated at less than \$500.00) for which the department will use its current M&O funding

Prepared by: Bruce Ertler
 Division: Engineering & Operations Division

Phone: 465-4703
 Date: 2/15/96

Approved by Commissioner: Joseph L. Perkins
 Joseph L. Perkins

Phone: 465-3901

Agency: Department of Transportation and Public Facilities

Date: 2/21/96

PREPARER TO PROVIDE ALL DISTRIBUTION COPIES TO GOVERNOR'S LEGISLATIVE OFFICE
 For further distribution information call the Governor's Legislative Office

SENATE COMMITTEE REPORT

First Committee of Referral

DATE: 3/25/96

FURTHER:

DATE TURNED INTO OFFICE: 4/2/96

The Transportation Committee considered HOUSE BILL NO. 498

"An Act naming the Bette Cato Bridge in Valdez."

and recommends:

- be replaced with _____ CS _____ (_____)
- adopt previous _____ CS _____ (_____)
- attached amendment(s)
- adopt Letter of Intent by _____ Committee
- further referral to the _____ Committee

- Senate Bill:
- same title
 - new title
- House Bill:
- same title
 - technical title
 - new: SCR^o _____

SIGNING DO PASS	DP	OTHER RECOMMENDATIONS	NR	DNP	AM
<i>Linda Green</i>	✓				
<i>[Signature]</i>	✓				
<i>Al Adams</i>	✓				
CHAIR: <i>Steve Ray</i>	✓	CHAIR:			

NEW FISCAL NOTE(S):

Department	Date	Zero	Fiscal

PREVIOUS FISCAL NOTE(S):*

Department	Date	Zero	Fiscal
DOT/PF	2/20/96	✓	

APPROPRIATION -- no fiscal note

*Include fiscal notes accompanying Governor's bill

Alaska State Legislature

House of Representatives



Transportation Committee

SPONSOR STATEMENT

HB 498

HB 498 will name the bridge over Mineral Creek on West Egan Drive in Valdez, the "Bette Cato" Bridge.

Representative Bette Cato was first elected to the State House in 1980 and served as the first and only Chair of the House Transportation Committee. During her five terms, Bette fought tirelessly to improve Alaska's transportation system and through her efforts, was instrumental in obtaining the funds for the construction of this bridge.

Therefore, it only seems appropriate that this bridge be named in honor and recognition of Ms. Bette Cato. She truly enriched the lives of those in Valdez and will always be remembered for her dedication and devotion to the State of Alaska.

CITY OF VALDEZ, ALASKA

RESOLUTION NO 96-28

A RESOLUTION OF THE CITY COUNCIL OF THE CITY OF VALDEZ, ALASKA, HONORING MRS. BETTE CATO AND NAMING THE BRIDGE OVER MINERAL CREEK ON WEST EGAN DRIVE THE "BETTE CATO BRIDGE"

WHEREAS, Mrs. Bette Cato represented the citizens of the State of Alaska and the City of Valdez during her five (5) terms in the Alaska State Legislature, and

WHEREAS, as a legislator she fought very hard to secure and protect funding for the Department of Transportation, Harborview, Prince William Sound Community College, and the Alaska Marine Highway;

WHEREAS, she took pride in her Navy career as an aviation machinist during World War II, later serving as Commander for American Legion Post #2 in Valdez and Vice Commander of American Legion Post #20 in Kenai; and

WHEREAS, Mrs. Cato enriched the lives of our young people as a High School teacher for twenty (20) years in Valdez, Anchorage and Kenai; and

WHEREAS, Mrs. Cato will be remembered for her strength, her kindness, and her dedication to the citizens of Alaska and to our City

NOW, THEREFORE, BE IT RESOLVED BY THE CITY COUNCIL OF THE CITY OF VALDEZ, ALASKA, that

the bridge over Mineral Creek on West Egan Drive shall be named

THE BETTE CATO BRIDGE

in honor of Mrs. Cato and in recognition of her accomplishment to obtain the funding for construction of West Egan Street and the bridge across Mineral Creek.

PASSED AND APPROVED BY THE CITY COUNCIL OF THE CITY OF VALDEZ, ALASKA, this 4th day of March, 1996.

CITY OF VALDEZ, ALASKA

John L. Harris
John L. Harris, Mayor

ATTEST

Sherril L. Caples
Sherril L. Caples, CMG, City Clerk





Alaska State Legislature

Please enter into the record my testimony to the (H) Transportation
 committee name
 committee on HB # 498 , dated 2-21-96
 bill/subject

Naming the "Betty Cato Bridge" as a friend
 & citizen of Valdez, remembering all the service
 Betty gave to this community - Her dedication
 to all of us - Not just this community
 but through out the whole district - Her Betty
 deserves recognition - without her - we
 would not have this bridge - This the
 majority of the citizens will be honored to
 call that "The Betty Cato Bridge on ~~the~~ west
 Legan Ave."

Signed: Danna M. Fisher
 Testifier
Private Citizen
 Representing (Optional)
Rt 335
 Address
907-835-4437
 Phone No.

Alaska State Legislature
Representative Eugene Kubina
Minority Whip

During Session
Alaska State Capitol
Juneau, Alaska 99801-1152
907) 465-4519
Fax: (907) 465-3797

During Interim
PO Box 2463
Valdez, Alaska 99656
(907) 635-2111
Fax: (907) 635-2057

MEMORANDUM

RECEIVED MAR 29 1996

TO: Senator Steve Reiger, Chairman
Senate Transportation Committee

FROM: Representative Gene Kubina 

DATE: March 28, 1996

RE: Scheduling of HB 498

I would like to respectfully request that you schedule HB 498 "An act naming the Bette Cato Bridge in Valdez", at your earliest convenience.

This bill was sponsored by the House Transportation Committee on behalf of the City of Valdez and passed out of the House unanimously on March 22nd.

It is my understanding that the House Transportation Committee has provided you with a copy of the bill, a sponsor statement, and back-up, however, if you should need additional information, please let me know.

HB

517

FISCAL NOTE

STATE OF ALASKA
1996 LEGISLATIVE SESSION

BILL NO: CSHB 517(TRA)

Revision Date: 03/7/96
 Title: An Act relating to motor vehicles commercial motor vehicles
 Sponsor: House Transportation Committee
 Requestor: H Transportation

Dept. Affected: Public Safety
 BRU: DPS Statewide Support
 Component: Commissioner's Office
 COMPONENT SERIAL NO. 0523

EXPENDITURES/REVENUES: (Thousands of Dollars) (inflation not included)

	FY 97	FY 98	FY 99	FY 00	FY 01	FY 02
OPERATING						
PERSONAL SERVICES						
TRAVEL						
CONTRACTUAL						
SUPPLIES						
EQUIPMENT						
LAND & STRUCTURES						
GRANTS CLAIMS						
MISCELLANEOUS						
TOTAL OPERATING	-0-	-0-	-0-	-0-	-0-	-0-
CAPITAL EXPENDITURES	-0-	-0-	-0-	-0-	-0-	-0-
CHANGE IN REVENUES ()	-0-	-0-	-0-	-0-	-0-	-0-
Revenue Code						

FUNDING: (Thousands of Dollars)

1002 Federal Receipts						
1003 GE Match						
1004 GE						
1005 GE/Program Receipts						
1006 GE/MHTIA						
Other						
TOTAL	-0-	-0-	-0-	-0-	-0-	-0-

Estimate of current year (FY 95) impact: \$ _____

POSITIONS:

FULL-TIME	0	0	0	0	0	0
PART-TIME	0	0	0	0	0	0
TEMPORARY	0	0	0	0	0	0

ANALYSIS (Attach a separate page if necessary)

This bill includes some housekeeping measures that simplifies several procedures affecting the operation of the Divisions of Motor Vehicles. It also provides for compliance with the Code of Federal Regulations, Title 49 of the Federal Motor Carrier Safety Assistance Program (MCSAP) and a compliance issue relating to the Commercial Motor Vehicle Safety Act (CMVSA) 49 CFR. Failure to maintain compliance with both the MSCAP grant and CMVSA may result in loss of the MSCAP grant funding and loss of 5 percent of federal highway aid funding.

Prepared By: Juanita M Hensley
 Division: Motor Vehicles

Phone: 465-2650
 Date: 03/07/96

Approved by Commissioner: Ronald L. Ote
 Agency: Ronald L. Ote, Dept. of Public Safety

Date: 3/8/96

PREPARER TO PROVIDE ALL DISTRIBUTION COPIES TO GOVERNOR'S LEGISLATIVE OFFICE

For further distribution information call the Governor's Legislative Office

FISCAL NOTE

STATE OF ALASKA
1996 LEGISLATIVE SESSION

BILL NO. CS HB 517 (TRA)

Revision Date: 3/7/96 Dept. Affected: DOT&PF
 Title: Motor Vehicles: Registration and Insurance BRU: Commissioner's Office
 Component: Office of the Commissioner
 Sponsor: House Transportation
 Requester: House Transportation COMPONENT SERIAL NO. 530

Expenditures/Revenues

(Thousands of Dollars)

OPERATING EXPENDITURES	FY 97	FY 98	FY 99	FY 00	FY 01	FY 02
PERSONAL SERVICES						
TRAVEL						
CONTRACTUAL						
SUPPLIES						
EQUIPMENT						
LAND & STRUCTURES						
GRANTS, CLAIMS						
MISCELLANEOUS						
TOTAL OPERATING	0.0	0.0	0.0	0.0	0.0	0.0

CAPITAL EXPENDITURES	0.0	0.0	0.0	0.0	0.0	0.0
----------------------	-----	-----	-----	-----	-----	-----

CHANGE IN REVENUES ()	0.0	0.0	0.0	0.0	0.0	0.0
------------------------	-----	-----	-----	-----	-----	-----

FUND SOURCE

(Thousands of Dollars)

FUND SOURCE	FY 97	FY 98	FY 99	FY 00	FY 01	FY 02
1002 Fed Receipts						
1003 GF Match						
1004 GF						
1005 GF/Program Receipts						
1006 GF/MHTIA						
Other						
TOTAL	0.0	0.0	0.0	0.0	0.0	0.0

Estimate of any current year (FY96) cost: \$ 0.0

POSITIONS

POSITIONS	FY 97	FY 98	FY 99	FY 00	FY 01	FY 02
FULL-TIME	0	0	0	0	0	0
PART-TIME	0	0	0	0	0	0
TEMPORARY	0	0	0	0	0	0

ANALYSIS: (Attach a separate page if necessary)

Portions of this bill will have a direct and positive impact on DOT&PF. This legislation will enhance the department's ability to better administer commercial vehicle activities. It provides clarity to existing law, defines certain violations which will result in the suspension or revocation of vehicle registration and/or special permits, and provides meaningful deterrents to owners and operators of commercial vehicles from operating vehicles that are out of compliance with safety standards and drivers licensing requirements.

Cost savings are not necessarily tangible and will not result in a direct budget reduction. The public safety will however, definitely be enhanced. By keeping commercial vehicles that have been placed out of service by the department off of the road until they have been repaired and reinspected, the public's exposure to unsafe commercial vehicles will be minimized. Subsequently, the state will be less at risk from possible litigation involving unsafe commercial vehicles.

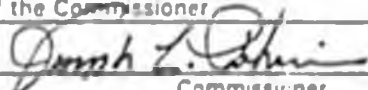
Prepared by: Sam Kito III  Special Assistant Phone: 465-3900
 Division: Office of the Commissioner Date: _____
 Approved by: Joseph L. Peltier  Commissioner Date: 3/7/96
 Agency: Department of Transportation and Public Facilities

PREPARER TO PROVIDE ALL DISTRIBUTION COPIES TO GOVERNOR'S LEGISLATIVE OFFICE
 For further distribution information, call the Governor's Legislative Office

SENATE COMMITTEE REPORT
First Committee of Referral

DATE: 3/26/96

FURTHER: FINANCE

DATE TURNED INTO OFFICE: 4/26/96

The Transportation Committee considered CS FOR HOUSE BILL NO. 517(TRA)(title am)
 Relating to motor vehicle regulation and insurance, efd.

and recommends:

- be replaced with _____ CS _____
- adopt previous _____ CS _____
- attached amendment(s)
- adopt Letter of Intent by _____ Committee
- further referral to the _____ Committee

- Senate Bill:**
- same title
 - new title
- House Bill:**
- same title
 - technical title
 - new: SCR³ _____

SIGNING DO PASS <u>4</u>	DP	OTHER RECOMMENDATIONS	NR	DNP	AM
<i>Kyle Olsen</i>	✓	<i>Deny</i>	✓		
<i>[Signature]</i>	✓				
<i>Bill Adams</i>	✓				
<i>Chris Taylor</i>	✓				
CHAIR: <i>Steve [Signature]</i>	✓	CHAIR:			

NEW FISCAL NOTE(S):

Department	Date	Zero	Fiscal

PREVIOUS FISCAL NOTE(S):*

Department	Date	Zero	Fiscal
Public Safety	3/8/96	✓	
DOT/PF	3/7/96	✓	

APPROPRIATION -- no fiscal note

*include fiscal notes accompanying Governor's bill

STATE OF ALASKA

Department of Public Safety

SPONSOR STATEMENT HOUSE BILL 517

Most Alaskans need a driver's license in order to carry on their daily lives. Obtaining license renewals and conducting other business with the Department of Public Safety, division of motor vehicles (DMV), can be time consuming. Most Alaskans have stood in line waiting to take care of business that require them to physically visit the DMV. This bill will make it easier for the Department of Public Safety to serve the public.

HB 517 will simplify procedures for obtaining a driver's license by removing exceptions to the renewal-by-mail program. Also, current law requires a person involved in an accident resulting in \$500 or more in damage to property to report the accident to the local police or the Alaska State Troopers for investigation. This amount was set in 1977; in present value, the slightest scrape can cost that much to repair. This bill raises the amount for required reporting to \$1,500.

HB 517 also provides for administrative hearings to be held by telephone in most instances to avoid costly travel. It allows the Department of Public Safety to keep its records electronically and provides that certified copies of those electronically stored records are admissible in courts and administrative hearings. It also allows a temporary permit issued by a car dealer to be valid for 60 days rather than 30 days, to give the dealer and the Department of Public Safety more time to take care of the necessary paperwork.

This bill also provides for compliance with the Code of Federal Regulations, Title 49, the Federal Motor Carrier Safety Act Program grant requirements, and item 22 of the Commercial Vehicle Safety Act 49 CFR parts 383, 390 and 391 dealing with disqualifying a commercial driver for an out-of-service violation. It makes housekeeping changes for compliance purposes. Failure to adopt the provisions of 49 CFR may result in sanction of 5 percent of federal highway monies and Federal Motor Carrier Safety Assistance Program Grant (MCSAP) funding.

Section 1. Records maintained electronically....This section will allow the use of certified electronic records in court in the same manner as the original paper document. With the transfer of traffic records between states, this will allow the storage of the electronically transmitted record to be used in lieu of the paper record. This is more efficient and well accepted practice.

Sections 2, 7-9. Administrative hearings by telephone. Allows administrative hearings to be conducted by telephone outside the central office area unless good cause exist for an in-person hearing. Hearings outside Juneau and Anchorage are currently scheduled to be conducted by telephone, but must be held in-person if the person requesting the hearing objects. Driver Services travel budget was reduced in FY94. A Highway Safety federally funded project was obtained to fund the hearing officer travel so the division could continue to conduct hearings in a timely manner and to get the drunk driver off of the road. This is the 1st year of the federal project money. Conducting administrative hearings by telephone is more cost efficient.

Section 3. This section extends the time period for a car dealer temporary permits to be extended from 30 days to 60 days. The 30 day permits are frequently inadequate to obtain title with liens, particularly from other states, and do the necessary processing to obtain an Alaska title. This is an efficiency measure.

Section 4. This section will authorize the department to revoke or suspend a CMV's registration if the owner/operator states that a "fix-it" violation has been repaired when it has not or if the owner/operator has failed to comply with a requirement that the CMV be reinspected after being placed out-of-service.

Section 5. Allows a private property owner to claim and title a vehicle that was abandoned without consent of the property owner. The vehicle must be abandoned for a period of in excess of three years.

Provided by the Dept. of Public Safety

Section 6. Lifts the restrictions for mail-in renewal of a driver's license. It deletes the provisions prohibiting renewal by mail when traffic convictions or license actions are evident within the previous five years. This is an efficiency measure.

Sections 7-9. See section 2.

Section 10-11. Allows the department to regulate the training requirements for commercial driving schools. It also creates a civil penalty for a person who operates a commercial driving school without receiving a proper license from the department.

Sections 12-18, & 25-26. Increases the amount of reportable property damage after a motor vehicle accident from \$500 to \$1,500. In 1970, the amount of reportable damage was \$200, in 1977, the amount was increased to \$500. Some police departments are not responding to vehicle accidents now unless there is in excess of \$1,500 or physical injury. This is considered an efficiency measure.

Sections 19 & 27. Alaska law exempts commercial vehicles in areas of the state where the average daily traffic is less than 499 vehicles traveling on the roads. These areas are not exempt from having to have a commercial driver's license to operate the size and class of vehicle as defined by federal law a commercial motor vehicle. Alaska does not have the authority to exempt commercial motor vehicles located in those areas which have fewer than 499 average daily traffic volumes from having to meet the safety inspections. This is a requirement under federal law, both under the MCSAP and Commercial Motor Vehicle Safety ACT (CMVSA).

Also, Section 19 changes from 300 to 150 the number of miles within which farm vehicles may travel and still not be considered commercial motor vehicles for the purposes of having to comply with the commercial motor vehicle safety equipment inspections. This is a requirement under federal law. MCSAP.

Sections 20 & 28. This section eliminates the requirement that the activity be in furtherance of the person's business; any business is sufficient. It deletes "PRIMARY". This is a requirement under federal law, both under MCSAP and CMVSA.

Section 21-24. These section adds a provision placing a person "out-of-service" for a violation of a regulation relating to safety equipment required on commercial vehicles and allows a person to be placed "out-of-service" when operating a commercial vehicle without a commercial driver's license. A driver who is convicted of a first violation of an out-of-service order is to be disqualified fro a period of no less than 90 days. Subsequent violations would lead to disqualification periods from one to three years. These sections are necessary for the state to achieve substantial compliance with the Commercial Motor Vehicle Safety Act of 1986. The deadline to achieving substantial compliance with this 22nd item of compliance is October 1, 1996. Failure to comply may result in sanctions of 5% federal highway funds effective OCTOBER 1996.

Section 24. Adds the definition of "out-of-service order".

Section 25-26. Refer to sections 12-13.

Section 27. Refer to section 19.

Section 28. Refer to section 20.

Section 29. This section repeals outdated statutes and allows for staggered registration for commercial vehicles. This statute was overlooked during other housekeeping measures in the past. This repealer will bring us to a practice which is in place today.

Section 30. Effect ve date of ACT.



US Department
of Transportation

Federal Highway
Administration

400 Seventh St., S.W.
Washington, D.C. 20590

Refer to: HCS-20

Ms. Juanita M. Hensley
Chief, Driver Services
Division of Motor Vehicles
Alaska Department of Public Safety
P.O. Box 20020
Juneau, Alaska 99802-0020

FEB 13 1996

Dear Ms. Hensley:

Thank you for your January 25, 1996 letter to Mr. Robert Redmond requesting confirmation that a State could be found not to be in substantial compliance with the commercial driver's license regulations if the disqualification of a commercial motor vehicle driver for violation of an out-of-service order is not adopted by October 1, 1996.

You are correct in your belief that a State must adopt and implement the new disqualification requirement for a violation of an out-of-service order by October 1, 1996. In both the "Deadline for Compliance" and "Structure" discussions in the preamble to the final rule "State Compliance With Commercial Driver's License Program" (Federal Register, May 18, 1994, Vol. 59, No. 95), the Federal Highway Administration clearly conveys the fact that State compliance with this 22nd requirement for State participation would not be required before October 1, 1996.

The "Substantial Compliance" discussion in the preamble to the final rule "Violations of Out-of-Service Orders by Commercial Motor Vehicle Operators; Disqualification and Penalties" (Federal Register, May 18, 1994, Vol. 59, No. 95), further conveys the fact that States must be in substantial compliance with this 22nd requirement for State participation by October 1, 1996.

While the effective date for this final rule was June 17, 1994, the State compliance deadline was deferred until October 1, 1996 to allow States sufficient time to take the necessary steps to assure compliance. Any State not meeting this deadline would be subject to sanctions as prescribed in 49 CFR 384.

I hope this information is helpful to you.

Sincerely yours,

James E. Scapellato, Director
Office of Motor Carrier
Research and Standards

cc: Linda Taylor (HSA-30)

MEMORANDUM

STATE OF ALASKA
DEPARTMENT OF PUBLIC SAFETY

TO: Senator Steve Rieger, Chair
Senate Transportation Committee

RECEIVED MAR 27 1996

FROM: Ron Otte
Commissioner
Department of Public Safety

DATE: March 26, 1996

RE: HB 517 scheduling

House Bill 517, which relates to the Division of Motor Vehicles and Commercial Motor Vehicles, was referred to your committee today with a further referral to the Finance Committee.

The bill includes some housekeeping measures that simplify procedures affecting the operation of the Division of Motor Vehicles. It also provides for compliance with the Code of Federal Regulations, Title 49 of the Federal Motor Carrier Safety Assistance Program (MSCAP) and a compliance issue relating to the Commercial Motor Vehicle Safety Act (CMVSA), 49 CFR. Failure to maintain compliance with both the MSCAP grant and the CMVSA by October 1996, may result in loss of the MSCAP grant funding and sanctions of 5 percent of the states federal highway funding.

I would appreciate it if you would schedule House Bill 517 at your earliest possible convenience. If you or your staff has any questions concerning this piece of legislation please do not hesitate to call Deputy Commissioner Del Smith or Sandy Perry-Provost at 465-4322.

Thanking you in advance for your attention to this request.

cc: Representative Gary Davis, Chair, House Transportation Cmte.
Pat Pourchot, Legislative Director, Governor's Office
Sandy Perry-Provost, Special Assistant, DPS
file



CENTER for EMPLOYMENT EDUCATION

Commercial Driving Instruction & Hazardous Material Training
1049 Whitney Road Anchorage, AK 99501 (907) 279-8451

April 25, 1996

Senator Rieger
Chairman House Transportation Committee
State Capital
Juneau, Alaska
99801-1182

Dear Senator Rieger and Members of the Senate Transportation Committee;

As you know, the Center for Employment Education (a non profit corporation) is Alaska's only certified Commercial Truck Driving School. Because of this distinction, approximately fifteen hundred (1500) students pass through our classrooms annually. Our students expect and receive training at the highest educational levels. In order to accomplish training at this degree, we must stay in tune to the needs of the industry we serve. That industry needs a Department of Public Safety that has the appropriate amount of funds to operate the Division of Motor Vehicles and the Commercial Vehicle Enforcement Division in a manner that efficiently serves the public.

We want the members of the Senate Transportation Committee to know that it is imperative HB 517 pass as it has been proposed. Alaska's transportation industry as well as the general public would benefit by this bill's passage.

Sincerely,

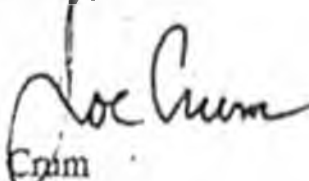
Joe Crim
Director of Training