

ALASKA LEGISLATURE COMMITTEE FILES, 1989-1990 8672  
6188 HOUSE TRANSPORTATION

592

# SOUTHEAST CONFERENCE

P.O. Box 22286

Juneau, Alaska 99802

January 25, 1990

The Honorable Richard Foster  
Chair, House Transportation Committee  
Room 17, Capitol Building  
Juneau, Alaska 99811

Dear Representative Foster:

The Southeast Conference, an organization representing the communities of Southeast Alaska, from governments to local businesses, is seriously concerned about the status of our Marine Highway.

Over the past five years, the Alaska Marine Highway System has experienced a decrease of 19% in general funding support to maintain its operations.

During that same time period the fleet of vessels has grown older and has reached the 20 - 30 year life span calculated for them when they were launched. Maintenance costs have increased and have placed a heavier burden on the Alaska Marine Highway System operating budget's decreasing resources. The net effect is the reduction in service to the communities and their businesses that rely on this highway for their economic and social linkage with each other and the rest of the state.

The SE Conference Board of Directors, on the recommendation of their AMHS Standing Committee, has adopted the following five planks as the SE Conference Platform relating to the Alaska Marine Highway System:

1. The passage of a supplemental appropriation for FY 90 for full funding of the Alaska Marine Highway System.
2. An increase in the FY 91 budget appropriation for the Alaska Marine Highway System to assure full service levels for the communities served by the System.
3. Allowing the Alaska marine Highway System to retain all the revenues it generates while maintaining a consistent level of general fund appropriation.
4. Completion of the AMHS Master Plan and allowing the Southeast Conference to be involved in the review and any modification of the Plan.
5. Creation of a Vessel Replacement Fund.

The Southeast Conference urges you to support HB No. 372 so that a vehicle for funding needed vessel replacement can be initiated this year.

Sincerely,

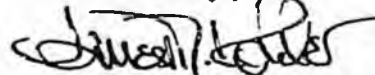

James M. Kohler  
Executive Director



# Representative Bette Cato, Chair House Transportation Committee

SUBJECT OF MEETING:

DATE:

PLACE:

NAME	REPRESENTING	BUSINESS/PERSONAL MAILING ADDRESS	ZIP	(H) PHONE	(W) PHONE	DO YOU WANT TO TESTIFY?	WHAT SUBJECT/ WHICH BILL?
Edward Moses	MOAS STDS DEPT of Commerce	P.O. BOX 111686	99511	278-3967 <del>345-7750</del>	545-7750	(Y) N	Air Carriers
John Halterman	ANHS				465-3950	Y N	HS 372
JAMES KOHLER	SE CONFERENCE	211 4th St. Suite 300/Juseum	99801		463-3442	(Y) N	HB 372
Leif Lee	Weather reporting Service					(Y) N	Air Carriers
Randall Burns	DLED Occupational Licensing	P.O. Box J, Juseum	99811			(Y) N	Air Carriers
						Y N	
						Y N	
						Y N	
						Y N	
						Y N	
						Y N	

AWS ← AWOS - PWA -  
ASSOS - NWS x 1992 begin

**H B**

**417**

# HOUSE COMMITTEE REPORT

(5)

Date Referred: February 2, 1990

FURTHER REFERRALS:

FINANCE

Date of Committee Action: \_\_\_\_\_

The TRANSPORTATION Committee considered:

HB 417

HOUSE BILL NO. 417

APPROP: SHIP CREEK TOWNSITE REDEVELOPMENT

"An Act making a special appropriation to the Alaska Railroad Corporation for road and bridge improvements for the Anchorage Ship Creek Original Townsite Redevelopment Project; and providing for an effective date."

**RECOMMENDATIONS:**

- be replaced with \_\_\_\_\_  the same title
- a new title
- have attached amendment(s)
- do pass
- do not pass
- no recommendation.
- individual recommendations
- additional referral to the \_\_\_\_\_ Committee

ADOPTS: \_\_\_\_\_ letter of intent

ATTACHES NEW FISCAL NOTE(S):  
(Dept)

APPROVES PREVIOUS:

(Date/Dept)

- fiscal impact \_\_\_\_\_
- zero fiscal note \_\_\_\_\_
- zero with analysis \_\_\_\_\_

- fiscal note(s) \_\_\_\_\_
- zero fiscal note(s) \_\_\_\_\_
- zero fn/analysis \_\_\_\_\_

**SIGNING DO PASS:**

\_\_\_\_\_  
*Steven D. Thomas*  
 \_\_\_\_\_  
*Richard J. Sobey*  
 \_\_\_\_\_  
 \_\_\_\_\_  
 \_\_\_\_\_  
 \_\_\_\_\_  
 \_\_\_\_\_  
 \_\_\_\_\_  
 \_\_\_\_\_  
 \_\_\_\_\_

**SIGNING:**

(Check appropr column)

	Do Not Pass	No Rec	Amend
<i>Bill Hulse</i>		<input checked="" type="checkbox"/>	
<i>Ben Sommers</i>		<input checked="" type="checkbox"/>	
<i>Yvonne Kubena</i>		<input checked="" type="checkbox"/>	
_____			
_____			
_____			
_____			
_____			
_____			

*Richard J. Sobey*  
 \_\_\_\_\_  
 Chairman's Signature

Rep. Kay Brown  
March 16, 1990

### House Bill 417

This measure appropriates \$2.5 million to the Alaska Railroad Corporation for road and bridge improvements for the Anchorage Ship Creek Original Townsite Redevelopment Project. It provides for: 1) construction and design of C Street realignment, 2) extension of Warehouse Avenue, and 3) construction of a Ship Creek pedestrian bridge.

The "tent city" of Anchorage had its beginnings in the Ship Creek area. It was here that construction camps were raised alongside the railroad during the development of the line between Seward and Fairbanks. As the city expanded to the south, the railroad lines and warehouse district became bordered by the Port of Anchorage and the hub of the downtown area. Although Anchorage grew rapidly, little development took place in the Ship Creek area outside of the Port expansion and the Railroad depot. This area, most of which is owned by the Railroad, has yet to meet its prime potential as a central location for tourism, recreation, and retail and commercial businesses.

The Redevelopment Project has progressed through the joint efforts of the Alaska Railroad Corporation, Glacier Brewery, Anchorage Economic Development Corporation, the Municipality of Anchorage, and local organizations. Glacier Brewery, which is scheduled to serve as one of the "anchors" for the project, has applied for a lease option for space to initiate an old fashioned Brew Pub, contingent upon the redevelopment of the area. The Pub will be open for tourists and residents, and transportation from downtown Anchorage will be provided by the Brewery during the tourist season and other appropriate times.

In November of 1989, an agreement was signed between the Alaska Railroad Corporation, Glacier Brewery and Anchorage Economic Development Corporation which memorialized a growing commitment and outlined duties of each party. During the same month, the Municipality of Anchorage and the Alaska Railroad reached agreements on improvements and projects that should be initiated to insure revitalization of the Ship Creek area, and provide mutual benefits for residents and tourists.

The funding in HB 417 is contingent upon the Alaska Railroad Corporation execution of a long-term lease agreement to the Municipality of Anchorage for the Government Hill bluff lands. It will be a 35-year lease, free of cost, with an optional renewal for another 35 years at no charge. The Government Hill Community Council has long awaited such a lease agreement in order to retain this area as open public space by incorporating it into the Municipality's greenbelt lands.

House Bill 417 would provide for three public works projects.

The Electric Dam Bridge would serve three objectives: 1) assist in the revitalization of the area; 2) create a pedestrian/bicycle crossing of Ship Creek; and, 3) promote continued viewing of scenery, waterfowl and salmon. The total length will be roughly 275 feet. The width is proposed at 12 feet to accommodate pedestrian and bicycle traffic. The bridge also will be wide enough to support emergency vehicles and small snow removal equipment. Design and construction of the bridge is budgeted at \$310,000.

Currently, Warehouse Avenue dead ends at the rail yard and has poor vehicular access and circulation. Traffic along Warehouse Avenue has to weave its way through the railroad yards from the east to access C Street. At many places along the route, commercial trucks block the entire road as they load and unload. The proposed project would extend Warehouse Avenue west to North C Street to create a primary eastbound route. It includes 1200 linear feet, paving, curb and sidewalk at \$270 per linear foot for a total cost of \$324,000.

Reconstruction and realignment of North C Street from 1st Avenue to Ocean Dock Road (including construction of a new bridge at Ship Creek) is the major project that is vitally needed to assure essential safe access to the Ship Creek area. The total projected cost is \$1,366,000. The existing road was constructed in the 1940s and '50s; it is not well developed and has poor alignment. Weight limits on North C Street have been already severely restricted because of safety concerns and structural deficiency. Reconstruction of C Street would establish an improved north/south link for continued Ship Creek development. In October of 1989 an independent study of the bridge was conducted; the bridge was determined to be functionally obsolete.

The Alaska Railroad will play a major role in the project. Its contributions include

- \* Government Hill bluff land lease agreement
- \* donation of historical railroad buildings to the project
- \* issuance of permits for rights-of-way at no charge involving for development of the area
- \* assist in procurement of all other necessary permits
- \* the fisherman's trail, access lanes, parking areas, and conversion of the existing trestle bridge to a fisherman's bridge
- \* installation of interpretive and historic signs
- \* adoption of covenants for affected and adjacent properties to allow future development of additional tourist facilities

The Ship Creek Original Townsite Redevelopment Project will stimulate the economy, create jobs, encourage business expansion in the area, revitalize a core area unique to Anchorage, promote tourism, and further develop recreational opportunities.

ORIGINAL TOWNSITE INFRASTRUCTURE  
CONSTRUCTION COST

November 1987 Estimate  
Alaska Railroad Corporation

-	Pedestrian Bridge (Clark-Grave estimate)		\$310,000
-	Warehouse Avenue Extension (to "C" Street, 1200 linear feet, paving, curb and sidewalk at \$270/lf)		\$324,000
-	"C" Street Alignment		
	Fill	\$150,000	
	800 linear feet, paving, curb & sidewalk	\$216,000	
	Sheet Pile Abutments	\$200,000	
	Bridge Span	\$600,000	
	Signals	\$200,000	
	TOTAL "C" Street ALIGNMENT		\$1,366,000
	TOTAL CONSTRUCTION Cost		\$2,000,000
	Contingency		\$200,000
	Architectural & Engineering Fees		\$200,000
	Administration		\$100,000

# MUNICIPALITY OF ANCHORAGE

# 1990 LEGISLATIVE PROGRAM

**CATEGORY:** Roadway Improvement

**TYPE OF IMPROVEMENT:** Full Improvement

**LOCATION:** "C" Street Bridge at Ship Creek and Warehouse Avenue

**1990 REQUEST:** \$2,500,000

**SOURCE OF FUNDING:** State Grant

**ESTIMATED ANNUAL O & M COST:** N/A

**PROJECT SCOPE:** This project consists of preliminary engineering, design and Phase I construction for a bridge at "C" Street crossing Ship Creek and the extension of Warehouse Avenue to "C" Street.

Included will be an investigation of alternate alignments considering the long range improvements planned for the port area and the environmental impact on Ship Creek.

Portion of the funds will be used for a footbridge/salmon viewing platform on the Knik Dam (CEA Dam) crossing Ship Creek.

The remaining portion of the funding is for the extension of Warehouse Avenue from the cul-de-sac west to "C" Street. This will provide alternate access to the east from the port and the proposed Ship Creek Landing development.

**CURRENT STATUS:** The existing "C" Street roadway bridge is in a deteriorated condition. The State is currently placing load limits on this bridge.

The Knik Dam (CEA Dam) is not being used for the generation of electrical power and has been decommissioned.

Traffic using Warehouse Avenue has to weave its way through the railroad yards from the east to access "C" Street. There are several places along that route where commercial trucks block the entire road while they load and unload.

**1990-1991 PROJECT PLAN:** The preliminary engineering and permit applications would be completed in 1990 and design work started on the various aspects of the improvements. Phase I construction will follow in 1991. This work will provide information for future funding requests and assist in coordinating future Ship Creek improvements according to the master plan.

**IMPACTS:** The preliminary engineering, design and Phase I construction will not have an immediate O & M impact, however it will greatly enhance planning for the Ship Creek Landing economic development. Various permits will be needed prior to the construction phase of this project.

## POLITICAL SUBDIVISIONS:

Community Council/Priority:	Downtown, Government Hill - N/A
Assembly Section:	1
Legislative District:	House - 12
	Senate - H



# ALASKA RAILROAD CORPORATION



P.O. Box 107500 • Anchorage, Alaska 99510-7500

November 21, 1989

The Honorable Tom Fink  
Mayor of Anchorage  
Municipality of Anchorage  
P.O. Box 196650  
Anchorage, Alaska 99519-6650

Re: Government Hill Bluff  
Original Townsite Development

Dear Tom:

For many years management of the Alaska Railroad Corporation ("ARRC") has been aware of a proposal to create a permanent park or greenbelt of those lands north of the rail yards and buffering the Government Hill residential community. This approximate 25 acre parcel of land, zoned R2-D, has development potential and therefore represents a substantial corporate real estate asset to the ARRC.

However, due to the adjacent residential neighborhoods of Government Hill most would agree the bluff lands are best left undeveloped as a greenbelt buffer. For this reason the bluff acreage was offered on several occasions to a prior administration in an attempt to exchange for other City owned commercial or industrial lands that the ARRC might put to income generating use.

Management and the Board of Directors recognize the importance of ARRC's participation within each railbelt community. To that end, should the Original Townsite Project improvements be funded, ARRC will in good faith make railroad lands adjacent Government Hill available to the community as a greenbelt or park. Those public improvements requested are as follows:

- Construction of the Ship Creek Dam Pedestrian Bridge.
- The extension of Warehouse Avenue to a realigned "C" Street.
- The Construction of the North "C" Street vehicular bridge and appropriate realignment of North "C" Street.

# **CORRECTION**

**THIS DOCUMENT  
HAS BEEN REPHOTOGRAPHED  
TO ASSURE LEGIBILITY**

# **CORRECTION**

**THIS DOCUMENT  
HAS BEEN REPHOTOGRAPHED  
TO ASSURE LEGIBILITY**

**MUNICIPALITY OF ANCHORAGE**

**1990 LEGISLATIVE PROGRAM**

**CATEGORY:** Roadway Improvement

**TYPE OF IMPROVEMENT:** Full Improvement

**LOCATION:** "C" Street Bridge at Ship Creek and Warehouse Avenue

**1990 REQUEST:** \$2,500,000

**SOURCE OF FUNDING:** State Grant

**ESTIMATED ANNUAL O & M COST:** N/A

**PROJECT SCOPE:** This project consists of preliminary engineering, design and Phase I construction for a bridge at "C" Street crossing Ship Creek and the extension of Warehouse Avenue to "C" Street.

Included will be an investigation of alternate alignments considering the long range improvements planned for the port area and the environmental impact on Ship Creek.

Portion of the funds will be used for a footbridge/salmon viewing platform on the Knik Dam (CEA Dam) crossing Ship Creek.

The remaining portion of the funding is for the extension of Warehouse Avenue from the cul-de-sac west to "C" Street. This will provide alternate access to the east from the port and the proposed Ship Creek Landing development.

**CURRENT STATUS:** The existing "C" Street roadway bridge is in a deteriorated condition. The State is currently placing load limits on this bridge.

The Knik Dam (CEA Dam) is not being used for the generation of electrical power and has been decommissioned.

Traffic using Warehouse Avenue has to weave its way through the railroad yards from the east to access "C" Street. There are several places along that route where commercial trucks block the entire road while they load and unload.

**1990-1991 PROJECT PLAN:** The preliminary engineering and permit applications would be completed in 1990 and design work started on the various aspects of the improvements. Phase I construction will follow in 1991. This work will provide information for future funding requests and assist in coordinating future Ship Creek improvements according to the master plan.

**IMPACTS:** The preliminary engineering, design and Phase I construction will not have an immediate O & M impact, however it will greatly enhance planning for the Ship Creek Landing economic development. Various permits will be needed prior to the construction phase of this project.

**POLITICAL SUBDIVISIONS:**

Community Council/Priority:	Downtown, Government Hill - N/A
Assembly Section:	I
Legislative District:	House - 12
	Senate - H



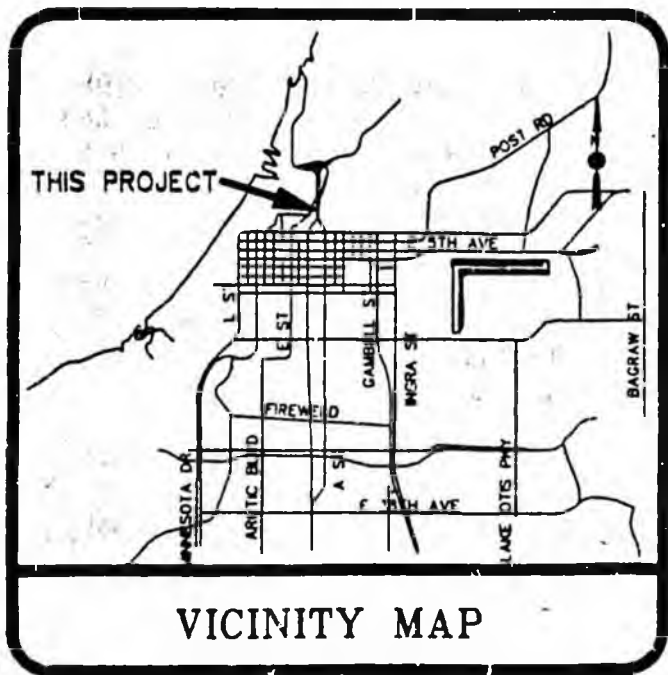
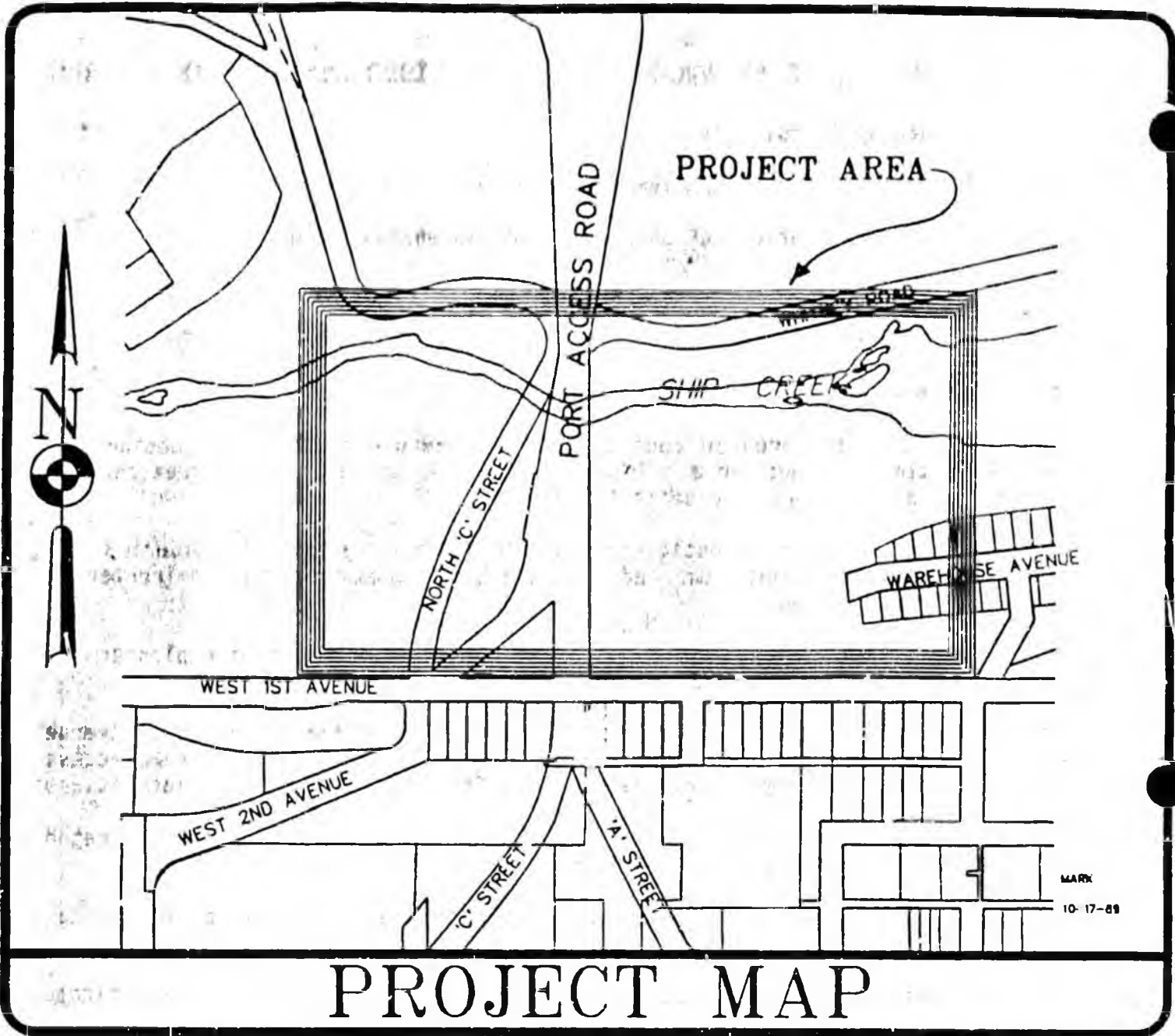

**ROADWAY  
IMPROVEMENT**

**FULL IMPROVEMENT**

**C STREET BRIDGE AT SHIP  
CREEK AND WAREHOUSE AVENU.**

# ALASKA RAILROAD CORPORATION



P.O. Box 107500 • Anchorage, Alaska 99510-7500

November 21, 1989

The Honorable Tom Fink  
Mayor of Anchorage  
Municipality of Anchorage  
P.O. Box 196650  
Anchorage, Alaska 99519-6650

Re: Government Hill Bluff  
Original Townsite Development

Dear Tom:

For many years management of the Alaska Railroad Corporation ("ARRC") has been aware of a proposal to create a permanent park or greenbelt of those lands north of the rail yards and buffering the Government Hill residential community. This approximate 25 acre parcel of land, zoned R2-D, has development potential and therefore represents a substantial corporate real estate asset to the ARRC.

However, due to the adjacent residential neighborhoods of Government Hill most would agree the bluff lands are best left undeveloped as a greenbelt buffer. For this reason the bluff acreage was offered on several occasions to a prior administration in an attempt to exchange for other City owned commercial or industrial lands that the ARRC might put to income generating use.

Management and the Board of Directors recognize the importance of ARRC's participation within each railbelt community. To that end, should the Original Townsite Project improvements be funded, ARRC will in good faith make railroad lands adjacent Government Hill available to the community as a greenbelt or park. Those public improvements requested are as follows:

- Construction of the Ship Creek Dam Pedestrian Bridge.
- The extension of Warehouse Avenue to a realigned "C" Street.
- The Construction of the North "C" Street vehicular bridge and appropriate realignment of North "C" Street.

Mayor Tom Fink  
Government Hill Bluff  
November 21, 1989  
Page 2

In our joint effort to achieve a common redevelopment goal the ARRC will at a minimum contribute the following:

- ° Grant a long term lease to the Municipality of Anchorage ("MOA") for the Government Hill bluff lands at no cost.
- ° Transfer to the MOA, subject to the existing leases, the Historic Government Hill Railroad Cottages.
- ° Donate surplus historical railroad buildings in the Ship Creek basin to the project.
- ° Issue permits for rights-of-way at no cost for the realignment and extension of Warehouse Avenue, the pedestrian footbridge over Ship Creek, the North "C" Street realignment, and other rights-of-way required for the development of the Project.
- ° Assist in the procurement of all other permits necessary for the Project and associated improvements; at its own expense provide the fisherman's trail, access lanes, parking areas, exclusive of traditional public infrastructures such as vehicle and pedestrian access, utilities and other public works.
- ° Provide at it's own expense for the conversion of the existing railroad trestle bridge to a Fisherman's Bridge as described in attachment "A." With the understanding that the bridge will remain operational in the event of an emergency.
- ° Provide area for the installation of interpretive historic signs and displays in cooperation with Anchorage Historic Properties, Inc.
- ° Adopt covenants for affected and adjacent properties compatible with the development of additional tourist activity in the Ship Creek basin.

Mayor Tom Fink  
November 21, 1989  
Page 3

The ARRC is encouraged by the prospects of this public/private joint effort to revitalize the Ship Creek area of downtown and create a true destination for residents and tourists alike.

By signature below we request that you and the City of Anchorage accept the Government Hill Greenbelt Park lands as of the date funding for the Original Townsite Improvements are in place.

Sincerely,



F.G. Turpin  
President and CEO

Concurrence:

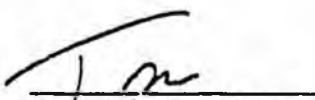
  
Tom Fink, Mayor

enclosure: Government Hill Greenbelt Park map

xc: ARRC Board of Directors  
M. J. Yetter, ARRC Vice President Finance  
Chairperson Heather Flynn, MOA Assembly  
The Honorable Rick Uehling  
The Honorable Pat Pourchet  
The Honorable Kay Brown  
The Honorable Johnny Ellis  
The Honorable Ramona L. Barnes  
The Honorable Alyce Hanley  
The Honorable H. A. "Red" Boucher  
The Honorable Virginia M. Collins  
The Honorable Dave Donley  
The Honorable Walt Furnace  
The Honorable Arliss Sturgulewski  
The Honorable Mike Szymanski  
The Honorable Max Gruenberg  
The Honorable Loren Leman  
The Honorable Terry Martin  
The Honorable Fritz Pettyjohn  
The Honorable Steve Rieger  
The Honorable Ann M. Spohnholz  
The Honorable Jan Faiks  
The Honorable Tim Kelly  
The Honorable Drue Pearce  
The Honorable Patrick Rodey  
Government Hill Community Council

## SHIP CREEK BASIN REDEVELOPMENT AGREEMENT

AGREEMENT made and entered into this 21 day of November 1989, by and between the Anchorage Economic Development Corporation ("AEDC"), the Alaska Railroad Corporation ("ARRC"), and Glacier Brewery, Inc. ("Glacier").

### RECITALS

A. Glacier intends to construct a brewery and pub ("Project") adjacent to the Chugach Electric dam on Ship Creek in the Municipality of Anchorage ("Municipality"). In order to construct and operate the Project, Glacier requires certain land permits and improvements to be furnished or constructed by ARRC and public financial assistance sufficient to permit the construction of a footbridge and vehicle bridge, road and other improvements.

B. ARRC desires to promote the economic development of its property in the Ship Creek area in order to increase the value thereof and the attractiveness of the area to tourists, residents and adjacent lessees.

C. AEDC desires to promote the economic development of the Municipality by assisting Glacier and ARRC in constructing and operating the Project, provided the Project will create new permanent jobs and enhance tourism in the Municipality, and by assisting ARRC to develop its property for tourism compatible purposes.

NOW THEREFORE, in consideration of the mutual promises set forth herein, the parties agree as follows:

#### 1. DUTIES OF GLACIER

a. Provided that suitable financing and all required permits can be obtained upon reasonable terms and within a reasonable period of time,

Glacier shall commence construction of the Project on the land provided by ARRC by June 30, 1991. The Project shall, on the average for the first five years of operation (the "Contract Period"), employ the equivalent of twenty full-time, year-round employees;

b. Glacier shall perform all janitorial maintenance on the footbridge and approaches at its own expense during the Contract Period. Such maintenance shall ensure that the property is neat and clean at all times, free of debris and trash, that the grass, shrubbery and plants are cut, watered, fed and neatly trimmed, and the lighting is operational, provided that Glacier shall be permitted to close the footbridge and approaches to the public during reasonable periods during the normal business day to perform such duties; and

c. During the Contract Period, Glacier shall provide scheduled transportation to and from the Project from the major downtown hotels on a daily basis during the summer tourist season and on an appropriate and reasonable basis during the remainder of the year.

## **2. FINANCING AND PERMITTING CONTINGENCY**

All obligations of Glacier hereunder are conditioned upon Glacier successfully obtaining suitable financing and all required permits, upon reasonable terms and within a reasonable period of time, before constructing and operating the Project. Glacier shall be released from its performance obligations hereunder if, after good faith efforts, it has been unable to obtain financing and all necessary permits upon such reasonable terms and within a reasonable period of time. The release of Glacier from its performance obligations hereunder shall not release ARRC from its commitments under Section 3, below.

### 3. DUTIES OF ARRC

ARRC shall:

- a. Provide the land for the Project and associated tourist compatible development, which will consist of the land identified in Attachment A (Original Townsite Study). All such property shall be improved to the extent that it is suitable for construction of improvements, exclusive of traditional public infrastructure such as vehicle and pedestrian access, utilities and other public works. It is understood that land occupied by Glacier and other private lessees will be leased at fair market value as governed by ARRC's lease policy;
- b. Provide permits for rights-of-way at nominal cost for (i) the realignment and extension of Warehouse Avenue, (ii) the design and construction of a footbridge over Ship Creek, (iii) the realignment of North "C" Street and associated bridge, and (iv) other rights-of-way required for the development of the Project;
- c. Provide all other permits necessary for the Project and associated improvements that it is empowered by law to provide;
- d. Provide, at its own expense, the fisherman's trail, access lanes, parking areas, and convert the existing bridge to a fisherman's bridge as described in Attachment A, exclusive of traditional public infrastructures such as vehicle and pedestrian access, utilities and other public works. It is understood that the train bridge may remain operational for emergency purposes;
- e. Donate historical railroad buildings in the Ship Creek area;

- f. Provide area for the installation of interpretive historic signs and displays in cooperation with Anchorage Historic Properties, Inc.;
- g. Adopt covenants for affected and adjacent properties compatible with the development of additional tourist activity in the Ship Creek basin; and
- h. Lease Government Hill Bluff land described in Attachment B to the Municipality at nominal cost for a period of not less than 35 years with an option for an additional 35 years.

#### **4. DUTIES OF AEDC**

AEDC shall:

- a. Use its best efforts to obtain funding in the approximate amount of \$2.1 million for the construction of the public infrastructure improvements recited in Section 3(b) above (the "Public Infrastructure Improvements") from state and/or local sources by July 1, 1990;
- b. Use its best efforts to cause the completion of construction of the Public Infrastructure Improvements by July 1, 1991;
- c. Assist as needed in obtaining necessary permits and regulatory approvals and coordinate efforts to obtain public and government support for the Project and Public Infrastructure Improvements;

#### **5. LIQUIDATED DAMAGES**

It is agreed that damages for failure to construct and operate the project are difficult to ascertain. Provided that AEDC and ARRC have fully performed all obligations hereunder, (i) the Public Infrastructure Improvements contemplated hereunder have been constructed in a timely manner, and (ii) the financing and permitting contingencies set forth in Article 2 have been satisfied, liquidated damages may be assessed against Glacier for any willful breach of its performance

obligations hereunder. In such event and in lieu of any other sum for damages, Glacier shall pay to AEDC, as liquidated damages, the sum of \$5,000 for each full-time equivalent job that does not exist short of the twenty required per year average which is required hereunder during the Contract Period. Notwithstanding the above, total damages assessable against Glacier hereunder shall not exceed \$25,000.

**6. WAIVER OF CLAIMS**

It is agreed and understood that AEDC is a nonprofit organization, that it is obligated only to expend its best efforts to fulfill its duties hereunder, and that it does not guaranty or warranty any performance hereunder.

ARRC and Glacier agree, jointly and severally, to hold harmless, defend and indemnify AEDC, its directors, officers, employees and agents under this agreement, except claims which might arise from any malicious and intentionally damaging actions of such directors, officers, employees or agents.

**7. EXTENSION OF TIME FOR PERFORMANCE**

The parties may extend the time for performance under this Agreement upon mutual consent, which consent shall not be unreasonably withheld and, in the case of delays in performance of their obligations by reason of (i) acts of God, (ii) restrictive government laws or regulations, including, but not limited to, delays created by reasons of processing times and/or other difficulties in obtaining required permits and/or, (iii) other causes without fault or reasonably beyond the control of any party, then the time period for completion of their obligations as described in Section 1 and Section 3 above shall be extended for a period corresponding to the effective lost time caused by such delay(s).

**8. TERMINATION OF AGREEMENT**

This Agreement shall terminate and no party shall have any liability hereunder upon the occurrence of any of the following events:

- a. Failure of the AEDC to cause the funding required by Section 4(a) to be committed by July 1, 1990;
- b. Failure of the AEDC to cause the completion of construction of the Public Infrastructure improvements by July 1, 1991.

**ALASKA RAILROAD CORPORATION**

By: *M. J. [Signature]*  
Its: President

**GLACIER BREWERY, INC.**

By: *M. L. L.*  
Its: President

**ANCHORAGE ECONOMIC DEVELOPMENT CORPORATION**

By: *Scott E. [Signature]*  
Its: President



**ANCHORAGE  
ECONOMIC  
DEVELOPMENT  
CORPORATION**

## **PRESS RELEASE**

*For More Information Contact*  
*Scott Hawkins, President, AEDC, 258-3700*  
*Marv Yetter, Vice President, Alaska Railroad, 265-2403*  
*Mark Wilson, Principal, Glacier Brewery, 276-4115*  
*John Burns, BCV Architects, 272-5533*

Released at 2 p.m., December 21, 1989

## **Ship Creek Redevelopment Agreement Inked**

The Alaska Railroad, a local entrepreneur, and the Anchorage Economic Development Corporation (AEDC) have signed a three-way agreement to develop a new tourism district in downtown Anchorage. Called the Original Townsite project, the development will involve a local brewery and "pub" similar to the brew-pubs that are popular in Europe.

It will also provide better and safer access to salmon viewing and fishing on Ship Creek, and will create a theme district based on turn-of-the-century architecture and amenities that were prevalent in the U.S. at the time Anchorage was first established as a construction camp for the Alaska Railroad. The district is located on the banks of Ship Creek where the first tents were pitched by Railroad workers.

The agreement culminates approximately 18 months of work by the three parties. It commits the Railroad to developing the district and the amenities and Glacier Brewery to developing the "brew-pub", if AEDC is successful in convincing the Alaska Legislature to fund \$2.1 million in road and bridge improvements in the area.

"Improved access to the area is critical to the success of the district," said John Burns of BCV Architects. "That's why the bridge and roadwork are an integral part of the project."

Marv Yetter, Vice President of the Alaska Railroad, characterized the agreement as a "win-win deal" for the community. "As part of this deal, the Railroad has agreed to turn over the Government Hill greenbelt for use as parklands, which residents in the area have long sought. We see that prime land as a trade for the State bridge and road work that is needed."

Mark Wilson, Principal of Glacier Brewery, says his company expects the brew-pub to create about 30 new jobs. "Every project needs an anchor. We have agreed to be that anchor, the first tenant for the new district. We're excited about combining tourism and local production of a premium beer. In addition, we'll be offering food, a soda fountain, and trolley-car transportation to downtown hotels during the summer months."

"There appears to be broad, bipartisan legislative support for this project," said Scott Hawkins, President of AEDC. "We feel that our part of the deal - obtaining the State funding - is very doable. All members of the downtown legislative delegation and the leadership of both the House and Senate are supportive." (Please call legislators for comment).

At the request of the Railroad, Glacier Brewery and AEDC, the Anchorage Assembly appropriated \$50,000 last July for preliminary design work, which was initially vetoed by Mayor Fink. Recently, the Assembly listed this project and the Alyeska Resort Infrastructure as its top two economic development requests for the 1990 legislative session.

# # #

**Additional Contacts:**

- Mayor Tom Fink: 343-4431
- Assembly Chair Heather Flynn: 272-5392
- Assemblyman Jim Barnett: 346-2755
- Senate President Tim Kelly: 561-7612
- Speaker of the House, Sam Cotten: 694-6683
- Representative Kay Brown: 561-7627
- Representative Johnny Ellis: 561-7628
- Senator Pat Pourchot: 561-7623
- Senator Rick Uehling: 561-7613



**ANCHORAGE**  
ECONOMIC  
DEVELOPMENT  
CORPORATION

## **Original Townsite Redevelopment Briefing Paper**

**GOAL:** To establish a tourism-oriented redevelopment on the south side of Ship Creek near Knik Dam, to be anchored by a subregional brewery and commercial tourism facility. The location is where the first tents were pitched by migrant workers in the early 1900's, marking the beginnings of Anchorage.

**BENEFITS:** Will initially create 20 to 30 permanent jobs; will extend and enhance the downtown tourism corridor; will stimulate a cleaning-up and redevelopment of the Ship Creek Basin; will establish the type of land use needed to enhance property values and finance the moving of the railyards to Birchwood.

**NEEDS:** Improved pedestrian and vehicular access. The current access is both unsafe and unworkable in terms of creating a tourism district and accommodating the resulting additional traffic in the area.

**PROPOSAL:** The AEDC has negotiated a three-way agreement with the Alaska Railroad and Glacier Brewery for development of Phase I. It includes commitments for site improvements, parking, a fisherman's trail, parkland, and other amenities from the Alaska Railroad. It also includes commitments from Glacier Brewery to build the brewery and tourism facility and create the jobs. All commitments are contingent upon \$2.1 million in access improvements. The access needs include realignment of North "C" Street bridge, extension of Warehouse Avenue, and a footbridge/viewing platform over Knik Dam.

**DETAILS:** The tourism facility to be developed by Glacier Brewery will include a brewery, beer garden, soda fountain and other retail space based on the "original townsite" theme. In addition, Glacier is committed to providing janitorial maintenance for the area and daily transportation to and from downtown hotels via "trolley" car. The Alaska Railroad's commitments include turning over the Government Hill Bluff greenbelt to the city for use as parkland.

550 West 7th Avenue  
Suite 1130  
Anchorage, AK 99501  
Telephone (907) 258-3700  
FAX (907) 258-6646

**Resolution of the Anchorage Convention & Visitors Bureau (ACVB) In Support of  
the Redevelopment of Ship Creek Basin**

WHEREAS, the Anchorage Convention & Visitors Bureau (ACVB) is charged with marketing Anchorage to visitors worldwide; and

WHEREAS, the availability of a larger number of interesting and unique attractions would improve the marketability of Anchorage as a visitor destination and further enhance the economic impact of ACVB's marketing programs; and

WHEREAS, revitalizing and redeveloping the Ship Creek Basin would be a major addition to the visitor attractions available in Anchorage; and

WHEREAS, a first step toward that end, the "Original Townsite" project, is being proposed in a cooperative effort between the Alaska Railroad, Glacier Brewery and the Anchorage Economic Development Corporation on the south side of Ship Creek, immediately adjacent and to the west of Knik Dam; and

WHEREAS, the proposal includes establishing a subregional brewery, associated visitor attractions, a redevelopment of the surrounding area -- including appropriate covenants, historic properties and pedestrian amenities -- as well as improved physical access to the area from downtown; and

WHEREAS, the involved parties are prepared to move forward this year if assurances can be provided that certain public infrastructure improvements are made; and

WHEREAS, those improvements include a footbridge and salmon viewing platform on top of Knik Dam, as well as realigning the North "C" Street bridge and approaches to improve access and address existing public safety problems in the area; and

WHEREAS, the cost of the public infrastructure improvements is estimated to total approximately \$1.8 million;

NOW, THEREFORE BE IT RESOLVED, that the Anchorage Convention & Visitors Bureau strongly urges the Alaska Railroad, Glacier Brewery and the Anchorage Economic Development Corporation to proceed with the "Original Townsite" project; and

BE IT FURTHER RESOLVED, that the Municipality of Anchorage and the Alaska Legislature are strongly encouraged to appropriate funding for the needed public infrastructure improvements in support of the project.

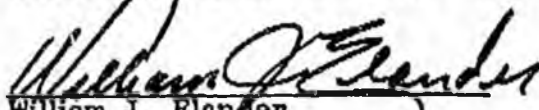
  
William J. Elander  
President  
Anchorage Convention &  
Visitors Bureau

  
William J. Dugdale  
Chairman  
Anchorage Convention &  
Visitors Bureau

# Downtown Community Council

145 West Sixth Avenue

Anchorage, Alaska 99501



(907) 279-5293

April 23, 1989

To The Alaska Legislature:

The Downtown Community Council endorses and supports current efforts which seek to improve the area at the mouth of Ship Creek. The impetus behind the improvements is the privately financed and locally owned Wetco Corporation and its newest offspring - The Glacier Brewery.

The brewery is the anchor for proposed improvements. Accessibility to the brewery is critical if it is to succeed as it should. The brewery will provide jobs and produce a product that we currently must import from Outside.

The brewery site is an area which we have turned our back on for many years. The proposed improvements will help bring it back to life. I've walked through the area with the proposed improvement plan in hand and agree that the improvements are necessary. The improvements mesh with the goals of a number of long term studies that have identified how the Ship Creek area should integrate industrial, recreational, esthetic and marine uses.

Last year representative of Wetco briefed the Downtown Community Council on their plans and we unanimously approved of their effort.

I encourage the representatives in the House and Senate from the district which this project is in to work with their colleagues to find and appropriate the \$4 million needed to make this project happen.

Thank you for your consideration.

Peter Roberts

President

Downtown Community Council



# FROM THE GRASS ROOTS

of

## MOUNTAIN VIEW

### MOUNTAIN VIEW COMMUNITY COUNCIL

3948 Mountain View Drive

Anchorage, Alaska 99508-1511

20 April 1989

The Anchorage Caucus  
P.O. Box V  
Juneau, Alaska 99811

Dear Anchorage Legislators:

Mark Wilson of Glacier Brewery presented their plans for rehabilitating the area between the Knik Dam and Ocean Dock to the Mountain View Community Council on Monday, April 10, 1989.

We think this is an exciting concept and support the plan as presented. It appears that they are working closely with all the entities in the area to make this a great tourist amenity as well as a private enterprise.

We would hope that the State of Alaska and the City of Anchorage will do all they can to make this plan a reality. We need more projects like this to revitalize our economy and to make our City a tourist destination instead of simply a place to transfer to some place else.

We all think Anchorage is a great place, but few tourists ever stay here - there simply is not enough to see and do to keep them here. It is time we "joined" the tourist trade as a way to wean ourselves from our dependency on the oil industry.

We think this "park" is a way to begin and fully support Glacier Brewery's efforts. They have promised to keep us informed on their progress and needs in the future.

Please join us in helping them in any way that you can.

Sincerely,



Randy Smith  
President

cc: Mayor Fink, Anchorage Assembly Members, Alaska Railroad,  
Glacier Brewery

NORTH "C" STREET  
CONCEPT/FEASIBILITY STUDY  
DECEMBER 1989

USKE, Inc.  
2515 A Street  
Anchorage, Alaska 99503  
(907) 276-4245  
Fax (907) 258-4653

INDEX

<u>SECTION</u>	<u>PAGE</u>
INTRODUCTION	1
NEW NORTH "C" STREET REALIGNMENT	1
ROADWAY GEOMETRY AND ALIGNMENT	2
BRIDGE DESIGN CONSIDERATIONS AND CRITERIA	4
SUMMARY OF QUANTITIES AND COSTS	5
CONCEPT COST ESTIMATES	6
HBRRP FUNDING ELIGIBILITY REQUIREMENTS	7
OLD "C" STREET SHIP CREEK BRIDGE RATING	9
BRIDGE RATING SUMMARY	11

LIST OF EXHIBITS

A	LOCATION MAP
B	NORTH "C" STREET PLAN
C	TRAFFIC PROJECTIONS
D	STREET SECTION
E	BRIDGE PROFILE
F	BRIDGE PLAN
G	BRIDGE SECTION

APPENDIX

A	SUFFICIENCY RATING WORKSHEETS
B	PHOTOGRAPHS - EXISTING TIMBER STRUCTURE

## NORTH "C" STREET CONCEPT/FEASIBILITY STUDY

### INTRODUCTION

Recent studies by the Municipality and others, including the Original Townsite Study (BCV/FMAA, December 1988), the Ship Creek Greenbelt Study (Department of Economic Development and Planning, 1988), the Ship Creek Concept Plan (Port of Anchorage, 1988) and the Phase III Coastal Trail Design Study Report (Capital Projects Office, 1987) have emphasized the development potential of lower Ship Creek for recreation and tourism activities associated with other uses including light industrial, commercial and retail. An essential element of the development plan is an improved network of streets and trails for pedestrian, bicycle, and vehicular traffic linking the CBD, Coastal Trail, Ship Creek Point, the Port and the proposed industrial/commercial development areas. The existing roadway system dates back to 1940's and 1950's construction and is not well developed with poor alignments, i.e., old "C" Street across Ship Creek, missing links, i.e., Warehouse Avenue and substandard intersections, roadway sections and traffic channelization.

### NEW NORTH "C" STREET REALIGNMENT

One of the initial projects under consideration by the Municipality of Anchorage in conformance with the overall lower Ship Creek development concept is the reconstruction and

realignment of North "C" Street from 1st Avenue to Ocean Dock Road (refer to Exhibit A, Location Map on the following page) including the construction of a new bridge at Ship Creek. The project would:

1. Establish an improved north/south link for continued lower Ship Creek development.
2. Provide a good connection to Ship Creek Point at a lower cost and higher level of convenience than other alternatives presented in the report: Transportation Analysis of the Proposed Ship Creek Waterfront project (Sverdrup December, 1987).
3. Provide an alternative access for freight haul to the Port of Anchorage in case of earthquake catastrophe. The existing timber structure is posted for reduced load limits as further described under the bridge sufficiency ratings sections of this study.

#### ROADWAY GEOMETRY AND ALIGNMENT

Exhibit B shows the proposed North "C" Street alignment providing a direct link between 1st Avenue and Ocean Dock Road. The geometry is relatively straight forward with a beginning point

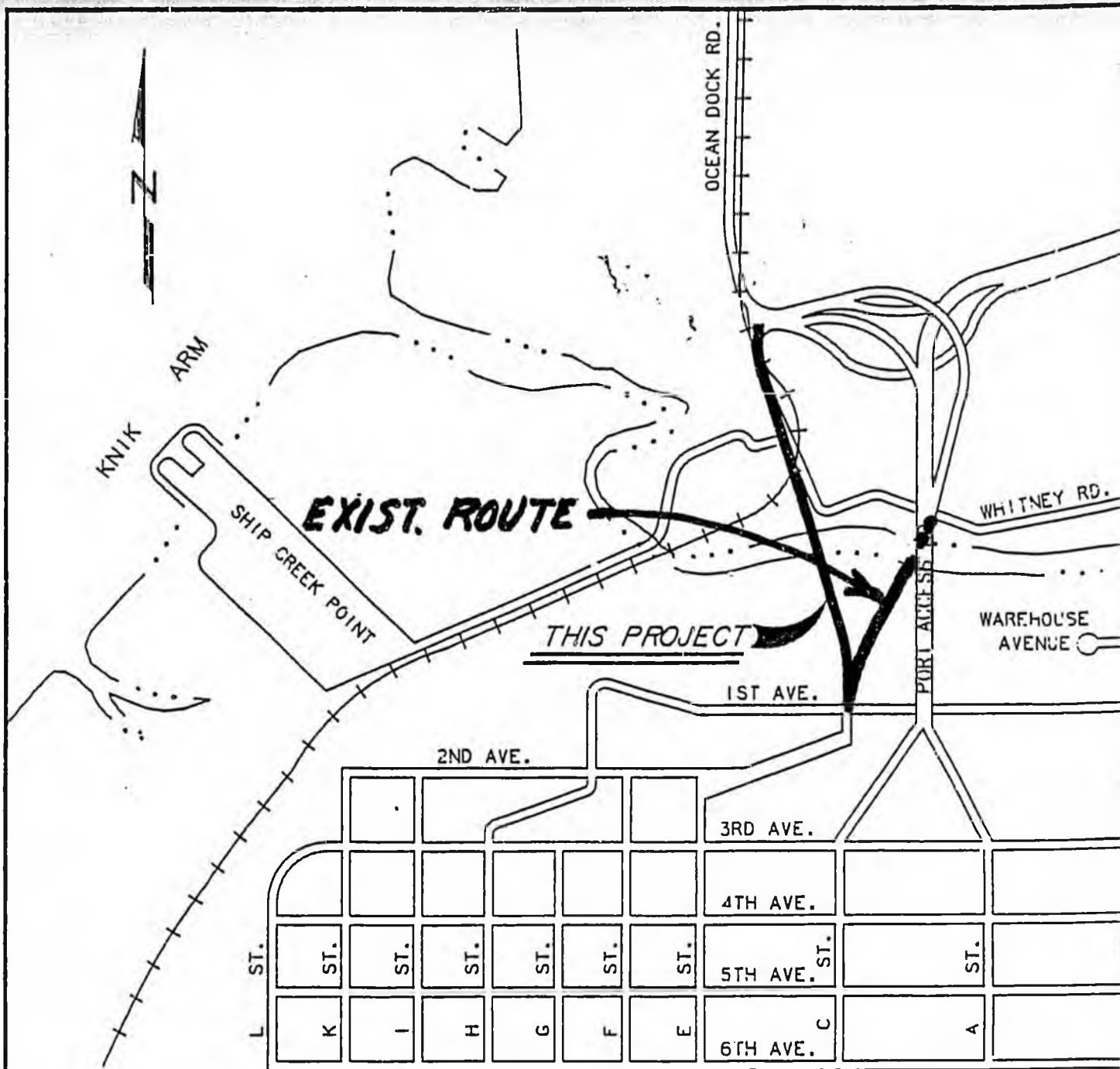

**EXHIBIT A**  
 CONCEPT/FEASIBILITY STUDY  
 LOCATION MAP  
**USKH**

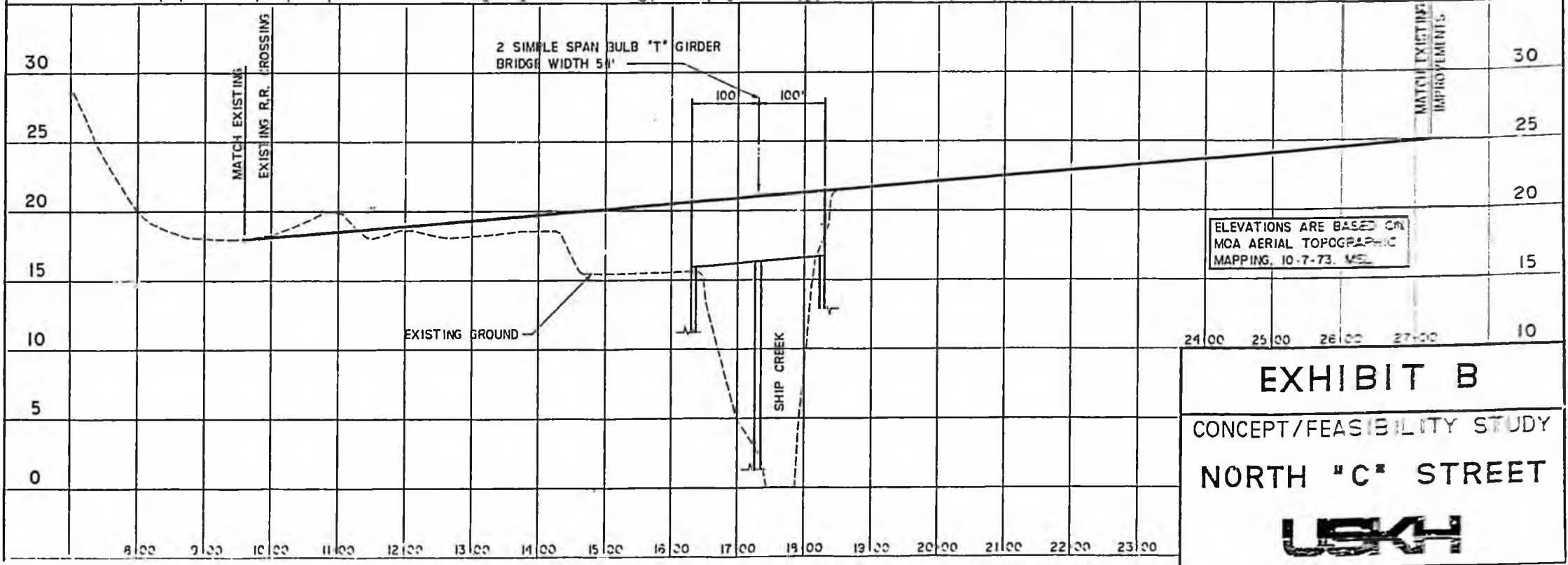
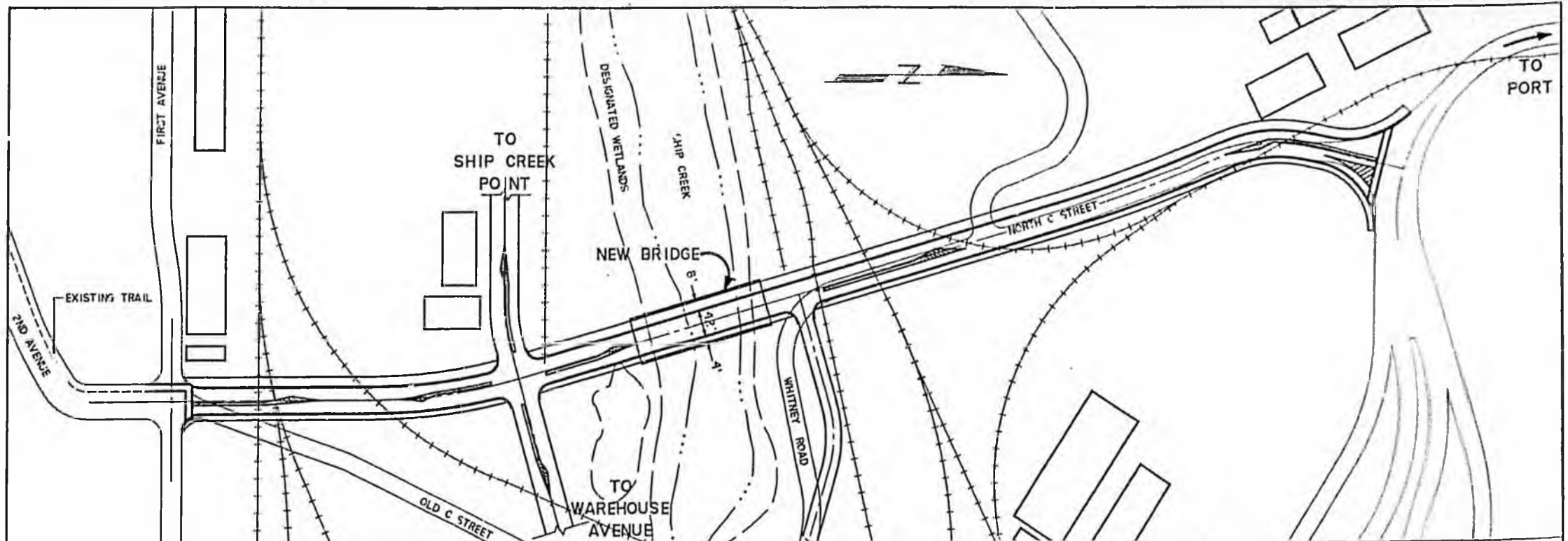

ELEVATIONS ARE BASED ON  
MCA AERIAL TOPOGRAPHIC  
MAPPING, 10-7-73. MSL

**EXHIBIT B**

CONCEPT/FEASIBILITY STUDY  
NORTH "C" STREET

opposite of and lining up with the existing "C" Street/1st Avenue intersection, then northerly on a tangent to an approximate 6° curve to the west with another tangent across Ship Creek and a tighter 200' radius curve tying into the existing Whitney Road/Ocean Dock Road intersection. Intermediate intersections would be provided at Whitney Road, the access road to Ship Creek Point and at the extension of Warehouse Avenue. Precise location and geometry of the intersections will require further study associated with continued lower Ship Creek development planning and a Design Study as the initial phase of design once funding is available.

Based on the projected traffic using the AMATS model (refer to Exhibit C, next page) with the Ship Creek 1992 road network and year 2010 demographics, volumes are projected to vary between 8,130 and 10,950 vehicles per day (ADT) by the year 2010. Using a peak hour factor of 10% and a directional split of 50/50, a lane volume of 500 to 550 vehicles per hour could be anticipated. This volume can be adequately carried (level of service B/C) by a two lane roadway with turn lanes and intersection channelization meeting the Minor Arterial II, commercial/industrial requirements (refer to Exhibit D, next page) as shown in the Municipality of Anchorage, Department of Public Works, and the Design Criteria Manual.



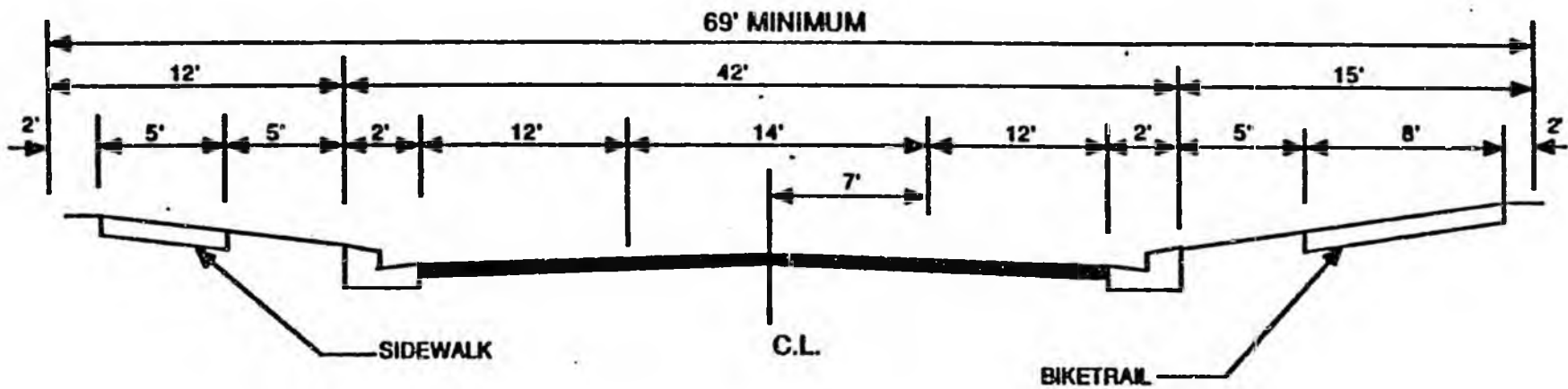

**MINOR ARTERIAL - II**  
**COMMERCIAL / INDUSTRIAL**

**EXHIBIT D**

CONCEPT / FEASIBILITY STUDY

STREET SECTION



Type I, Curb and Gutter is recommended at all intersections and at the bridge approaches for traffic control and safety. Because of the number of railroad crossings, the remaining segments may be strip pavement only. An 8' to 10' wide bike/pedestrian trail (shown on the west side of the improvement for concept review only) will be a necessary link for future connections to the Fishermen's Trail and other Ship Creek trails.

#### BRIDGE DESIGN CONSIDERATIONS AND CRITERIA

The recommended bridge for the Ship Creek crossing is a two span, precast concrete superstructure, utilizing cast-in-place abutments and a central pier supported on piling. This concept is shown on Exhibits E, F, and G following. Other bridge features include tube metal bridge railing and barrier between the pedestrian/bike trail and the traffic lanes, epoxy coated rebar and concrete pile encasement for several feet below existing stream bottom to several feet above extreme high tide on the central pier. From the standpoint of construction simplicity, long term maintenance, aesthetics and economics, the bulb T girder appears the most reasonable construction choice. The total span length of 200 feet provides the necessary clearance over the existing Ship Creek channel as well as the adjacent designated wetland areas. A deck elevation of approximately 21' MSL will be required to provide the necessary underclearance for the full range of tidal conditions.

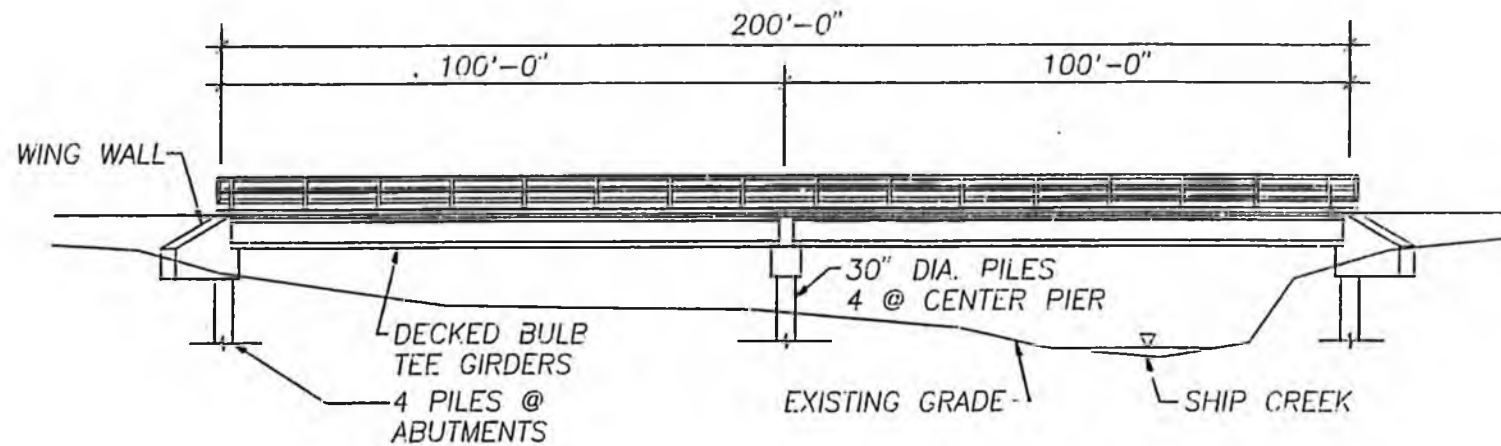

PROFILE

SCALE 1"=20'

EXHIBIT E

CONCEPT/FEASIBILITY STUDY

BRIDGE PROFILE



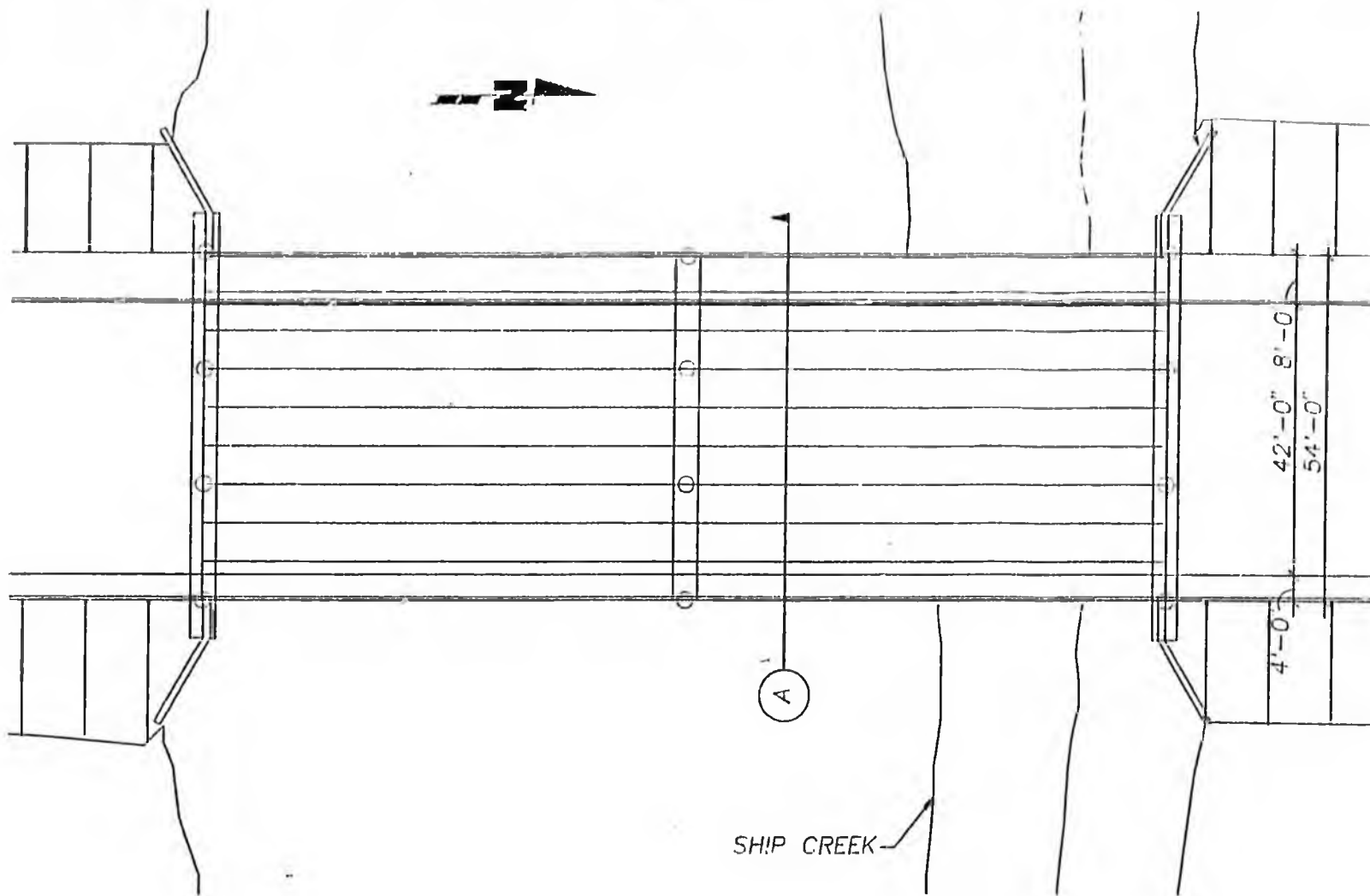

PLAN

SCALE 1" = 20'

EXHIBIT F

CONCEPT/FEASIBILITY STUDY

BRIDGE PLAN



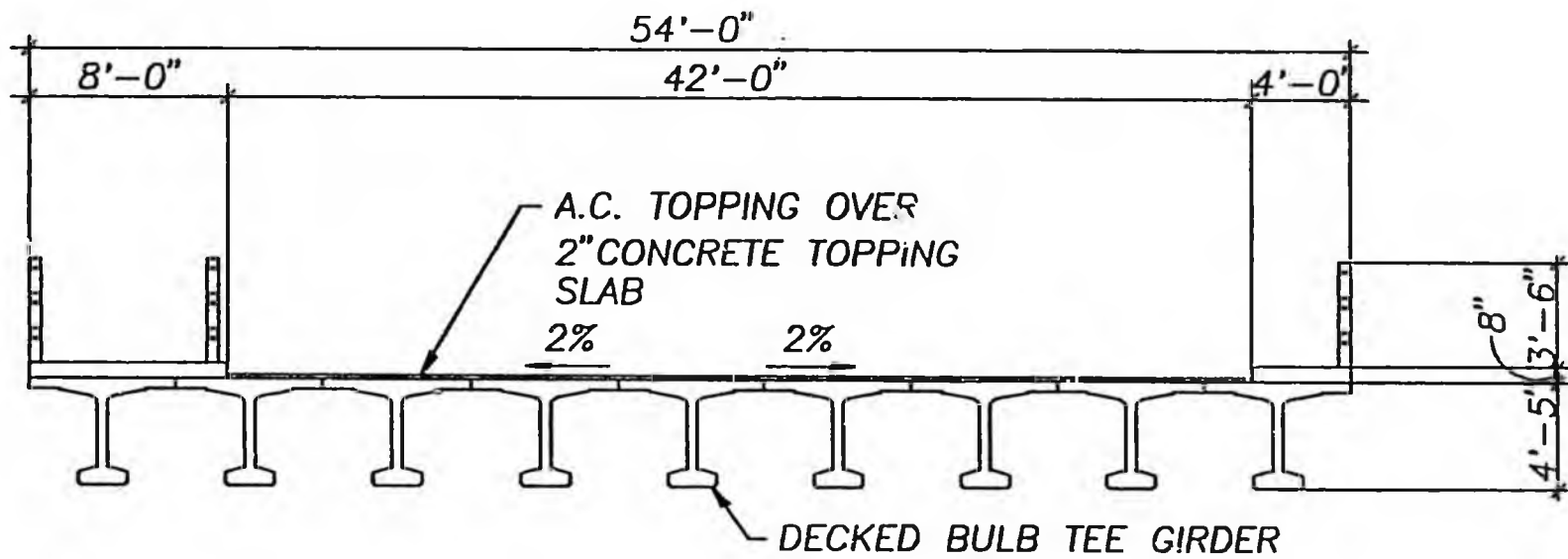

SECTION A

**EXHIBIT G**

CONCEPT/FEASIBILITY STUDY

**BRIDGE SECTION**



## CONCEPT COST ESTIMATES

The bridge and street construction cost are shown on the following page. The cost estimates are based on unit prices for similar projects in the Anchorage area and on quotations from material suppliers. Quantities are based on the assumed conditions and layout described in this study. Costs for utility construction or relocation and for bridge and roadway demolition and obliteration are not included. Also normal costs for engineering, construction inspection, and project administration are not included.

## BRIDGE INSPECTION PROGRAM

The 1987 Surface Transportation and Uniform Relocation Assistance Act (STURAA) continued the National Bridge Inspection Standards (NBIS) and the Highway Bridge Replacement and Rehabilitation Program (HBRRP). In the State of Alaska, the program is presently funded at between \$3.5 and \$4 million annually.

The Federal Highway Administration (FHWA) administers both the National Bridge Inspection and Highway Bridge Replacement and Rehabilitation Programs. The FHWA division office in Alaska monitors state compliance to the NBIS and HBRRP programs and

SUMMARY OF QUANTITIES AND COSTS

<u>ITEM</u>	<u>APPROXIMATE QUANTITY</u>	<u>UNIT</u>	<u>UNIT COST</u>	<u>AMOUNT</u>
<b>ROADWAY</b>				
Excavation	8,000	Cubic Yards	\$5	\$40,000
Backfill	30,000	Tons	\$7	\$210,000
Curb and Gutter	1,000	Lineal Feet	\$12	\$12,000
Base Coarse	3,000	Tons	\$15	\$45,000
AC Pavement	2,500	Tons	\$50	\$125,000
Railroad Crossing	6	Each	\$8,000	\$48,000
Storm Drain	800	Lineal Feet	\$80	\$64,000
Landscaping	1,500	Lineal Feet	\$20	<u>\$30,000</u>
<b>SUBTOTAL ROADWAY</b>				<b>\$574,000</b>
<b>BRIDGE SUPERSTRUCTURE</b>				
53" Girders	1,800	Lineal Feet	\$400	\$720,000
AC Topping	SEE ABOVE			
Bridge Railing/ Traffic Barrier	600	Lineal Feet	\$100	\$60,000
Miscellaneous	1	Lump Sum	Lump Sum	\$60,000
<b>BRIDGE SUBSTRUCTURE</b>				
Concrete	175	Cubic Yards	\$700	\$122,500
Reinforcing	30,700	Pounds	\$1.10	\$33,770
30" Piling	1,560	Lineal Feet	\$50	\$78,000
Miscellaneous	1	Lump Sum	Lump Sum	<u>\$50,000</u>
<b>SUBTOTAL BRIDGE STRUCTURE</b>				<b>\$1,124,270</b>
<b>ESTIMATED TOTAL CONSTRUCTION COST</b>				<b>\$1,698,270</b>

other requirements. The division office also approves state applications for specific replacement/rehabilitation projects.

The State's and/or Local governments are responsible for inspecting their bridges in conformance with the National Bridge Inspection Standards. Additionally, each state is responsible for maintaining an accurate and current inventory and submitting specified inventory data including inspection results to FHWA for its National Bridge Inventory System.

#### **HBRRP FUNDING ELIGIBILITY REQUIREMENTS**

Based on the inventory data submitted annually by the states, FHWA classifies each bridge as not deficient, structural deficient, or functionally obsolete. FHWA defines a structurally deficient bridge as one that is weak and has been restricted to light vehicles, closed, or which needs immediate rehabilitation to remain open. A functionally obsolete bridge is one that has inadequate deck geometry (usually means the deck is too narrow), is improperly aligned with the roadway leading to it or has an inadequate load carrying capacity or insufficient underclearances and is no longer safe. In addition to categorizing each bridge structure as functionally obsolete or structurally deficient, the inspection program determines a sufficiency rating for each structure in the inventory. The sufficiency rating is a number

from 0 to 100 which is arrived at by applying a mathematical formula to the inventory data. The sufficiency rating formula is a method of evaluating the sufficiency of a bridge to remain in service in its present condition. A rating of 100 represents an entirely sufficient bridge, a rating of 0 indicates an entirely insufficient or deficient bridge. The formula's three general factors and their relative weights are: Structural inadequacy and safety - 55%; serviceability and functional obsolescence - 30%; and essential factor for public use - 15%.

From the data base which FHWA maintains, an annual report is submitted to the states listing bridges that are either structurally deficient or functionally obsolete and have sufficiency ratings of 80 or less. These bridges are eligible for replacement or rehabilitation under the bridge program. The states and/or local governments may select any bridge on the listing and apply for fundings under the HRRP. Bridges with sufficiency ratings below 50 can be replaced and/or rehabilitated. Bridges with sufficiency ratings 50 - 80 generally can only be rehabilitated.

#### **OLD "C" STREET SHIP CREEK BRIDGE RATING**

Under the statewide bridge inspection and inventory system, the Old "C" Street Ship Creek bridge is numbered 417. The bridge was

last inspected by the state's bridge inspection team in June 1989, with an overall sufficiency rating of 44.3 (not deficient).

During October 1989, a structural engineering team from USKH conducted an independent inspection of the bridge in conformance with the AASHTO Bridge Manual. Based on the future traffic projections, and the inspection ratings summarized in Appendix A, the bridge received a sufficiency rating of 34.2 (functionally obsolete). The primary reasons for the lower rating include:

Item No. 60 Substructure

Piles at south retaining wall under abutment are deteriorated and need replacement. Piles at piers are badly abraded at stream surface at low tide line (see Photographs Appendix B). Some piles at the upstream side of the piers are reduced to about 75% to 80% of original cross section. Many piles show abrasion at the low tide line.

Item #61 Channel Protection

Little or no riprap is visible near the bridge. The stream has changed course such that the water is flowing at about 45° to the road alignment flowing toward the south abutment with strong potential for erosion.

Item #64 Operating Rating

A posting limit of maximum tandem axle group of 22,000 lbs has recently been applied to the bridge.

Item #67 Structural Conditions

The bridge meets minimum tolerable limits for a route with commercial traffic. The low weight limit is based primarily on on super structure condition from the June DOT/PF inspection. The October inspection also identified some substructure concerns.

Item #68 Deck Geometry

The deck width is less than traffic surface giving a rating of 3 or less.

Item #70 Safe Load Capacity

The safe load capacity is less than desirable since this route could be used to access Port (freight route).

Item #71 Waterway Adequacy

The potential for erosion on south abutment is high due to present stream flow.

## BRIDGE RATING SUMMARY

Based on an independent inspection and analysis, USKH believes the bridge meets the conditions for inclusion on the list of bridge structures currently eligible for HBRRP funding for the off-road system. Further, bridge funds were not used for construction of existing Port Access structure. Therefore, eligibility for replacement remains available. The Municipality, through the area wide streets and highways planning process should proceed accordingly.

APPENDIX A  
SUFFICIENCY RATING WORKSHEETS

CALCULATE SI - STRUCTURAL ADEQUACY

ITEMS # 59 7  
# 60 5  
# 66 228

A, B & C = 0, D = 10%

ADJUSTED INVENTORY RATING (AIR)

AIR = 28 x 100 = 2800

I. FACTOR

$I = (30 - A)^{1.5} \times 0.2778$   
 $I = (30 - 10)^{1.5} \times 0.2778$   
 = 24.8

AIR = 216 (PEL DOT REVIEW)

SI FACTOR

$SI = 55 - (A + B + C + D + E + F + G + H + I)$   
 = 55 - (0 + 0 + 0 + 10 + 0 + 0 + 0 + 0 + 24.8)  
= 20.2

SERVICEABILITY AND FUNCTIONAL OBSOLESCENCE

WIDTH OF ROADWAY INSUFFICIENCY

ITEM #58 = 7 ∴ A = 0  
 ITEM #67 = 4 ∴ B = 2%  
 ITEM #68 = 3 ∴ C = 4%  
 ITEM #69 = N ∴ D = 0  
 ITEM #71 = 3 ∴ E = 4%  
 ITEM #72 = 5 ∴ F = 1% (PEL DOT REVIEW)

$J = (A + B + C + D + E + F)$   
 = 0 + 2 + 4 + 0 + 4 + 1

J = 11

NOTE #1

$$\begin{aligned} \#51 + 2ft &= 0255 + 2 = 0275 \\ \#32 &- 024 > 0275 \quad \therefore G = 5\% \end{aligned}$$

NOTE #3

#28 = 0200

#29 (ADT) = 002015

REVISED PER MOA ESTIMATE 9790  
11/21/89

X = ADT / # OF LANES

#29 / #28 = 002015 / 2 = 1003

+395

Y = BRIDGE PAVY WIDTH / LANES

= #51 / #28 = 0255 / 2 = 12.75

LIMITS DO NOT APPLY FOR NOTE #3

NOTE #4

X > 375 BUT ≤ 1350      12 ≤ Y < 16

∴ H = 15 ( (16 - Y) / 4 ) %

H = 15 ( (16 - 12.75) / 4 ) = 12.25

REVISED H PER NEW MDT = 15%

VERTICAL CLEARANCE INSUFFICIENCY

I = 0%      INDEPENDENT OF DEFENSE ROAD SLOPE

S<sub>2</sub> = 20 - [ J + (G + H) - I ]      G + H ≤ 15

= 20 - [ 11 + (15) + 0 ]

= 4%

REVISED H DOES NOT AFFECT SL FALD

ESSENTIALITY FOR PUBLIC USE

K = (S<sub>1</sub> + S<sub>2</sub>) / 85 = (20.2 + 4) / 85 = 0.28

ESSENTIALITY (Cont)

$$A = \frac{\#19 (ADT) \times \#12 (DETAIL LENGTH)}{200,000 \times K} \times 15$$

$$= \frac{2015 \times 2}{200,000 (0.28)} \times 15$$

$$= \underline{1.08}$$

$$= \frac{9790 \times 2 \times 15}{200,000 (0.28)}$$

$$= 5.24$$

REVISOR PER  
NEW ADT  
ESTIMATE

ITEM #12 = 0 ∴ B = 0

S3 FACTOR

$$S_3 = 15 - (A+B)$$

$$= 15 - (1.08 + 0)$$

$$= 13.92$$

OR 11.92 (FSL DEFENSE ROAD)

9.76 REVISOR PER NEW ADT EST

SPECIAL RESTRICTIONS

$$S_1 + S_2 + S_3 > 50$$

$$S_1 + S_2 + S_3 = (20.2 + 4 + 13.9) = 38.1 < 50$$

EELONES INDEPENDENT OF MILITARY ROAD STATUS

$$S_4 = 0$$

$$\text{SUFFICIENCY RATING} = S_1 + S_2 + S_3 - S_4$$

$$= 38.1$$

SUFFICIENCY RATING =  $S_1 + S_2 + S_3 - S_4$   
 $= 20.2 + 4 + 9.76$   
 $= 34$   
 REVISOR PER NEW ADT ESTIMATE

Notes - STRUCTURAL ITEMS USED IN SUFFICIENT EXISTING

# 29 ADT

# 72 ADEQUACY OF APPROXIMATE ALIGNMENT  
(USED DOT VALUE)

# 66 INVENTORY RATINGS (USED DOT VALUE)

CODE

ITEM #32		034
ITEM #45		006
ITEM #46	NO APPROACH SPANS	0000
ITEM #47		240
ITEM #48	1/2 SPAN	0028
ITEM #49		000144
ITEM #50	12x12 TIMBER CURB	006006
ITEM #51		0255
ITEM #52		0250
ITEM #53		380.7
ITEM #54		0000
ITEM #55		999
ITEM #56		999
ITEM #57	WOOD DECK w/ ASPHALT CONCRETE OVERLAY	J
ITEM #58	GENERALLY GOOD	7
ITEM #59		7
ITEM #60		5
ITEM #61	LITTLE TO NO RIPRAP UNDER BRIDGE. MAIN STREAM FLOW @ 45° TO ROAD ALIGNMENT FLOWING TOWARD S. ABUTMENT.	5
ITEM #62		4
* ITEM #63		
* ITEM #64	22000# TANDEN AXLE GROUP	225
* ITEM #65	:	5
* ITEM #66	22000# TANDEN AXLE GROUP	216 (PEL DOT)
ITEM #67	MEETS MIN. TOLERABLE LIMITS.	4
* ITEM #68		3
ITEM #69		N
ITEM #70		#3

CODE

ITEM # 71

SCOUR OF TIMBER PILES EVIDENT

3

POTENTIAL EROSION PROBLEM @ SOUTH  
ABUTMENT DUE TO STREAM FLOW ALIGNMENT.

ITEM # 72

APPROACH ALIGNMENT.

MEMORANDUM

TO: Ed Riggs  
FROM: Bruce Hooper  
DATE: Oct 12, 1989  
SUBJECT: C Street Efficiency Rating

---

Below is the basis for the rating given on each of the items on the efficiency rating.

Item #32. #45 - #56  
Based upon field measurements.

Item #57 - Wearing Surface  
Wearing Surface - 4" wood deck with asphalt overlay.

Item #58 - Deck  
Deck - wood decking in good condition, asphalt overlay requires some minor repairs, primarily seal cracks.

Item #59 - Superstructure  
Superstructure is generally in good shape. Minor repairs required on the curb timbers and pipe support brackets.

Item #60 - Substructure  
Piles at retaining wall under abutment are deteriorated and need replacement. Piles at piers are abraded at stream surface at low tide point (See Photos). Some piles at upstream side of piers reduced to about 75% - 80% of original cross section. Others show abrasion but only a slight reduction in cross section.

Item #61 - Channel Protection  
Little to no riprap visible under bridge. Stream has changed course such that the water was flowing at about 45 degrees to the road alignment flowing toward the south abutment with strong potential for erosion.

Item #64 - Operating Rating  
Maximum Tandem Axle group load posted at 22000 pounds.

Item #65 - Approach Alignment  
Acceptable

Item #67 - Structural Conditions  
Bridge meets minimum tolerable limits for route with commercial traffic. Low weight limit based primarily on substructure condition.

Item #68 - Deck Geometry

Deck width less than traffic surface (a(b) giving rating of 3 or less.

Item #70 - Safe Load Capacity

Less than desirable since this route is used to access port (Freight route).

Item #71 - Waterway Adequacy

Potential for erosion into south abutment exists due to present stream flow.

APPENDIX B  
PHOTOGRAPHS - EXISTING TIMBER STRUCTURE



SECOND PIER IN FROM NORTH ABUTMENT. NOTE PILE ABRASION AT THE WATERLINE AND CHECKING IN BRACING MEMBERS.

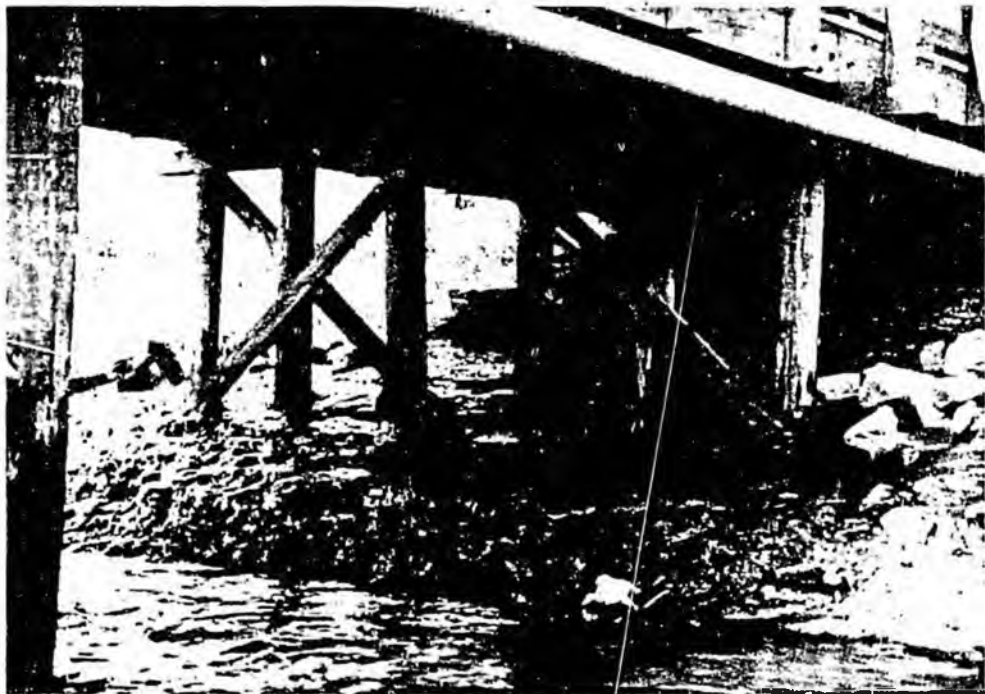

FIRST PIER IN FROM NORTH ABUTMENT. PILE ABRASION AND DEGRADATION OF BRACING APPARENT.

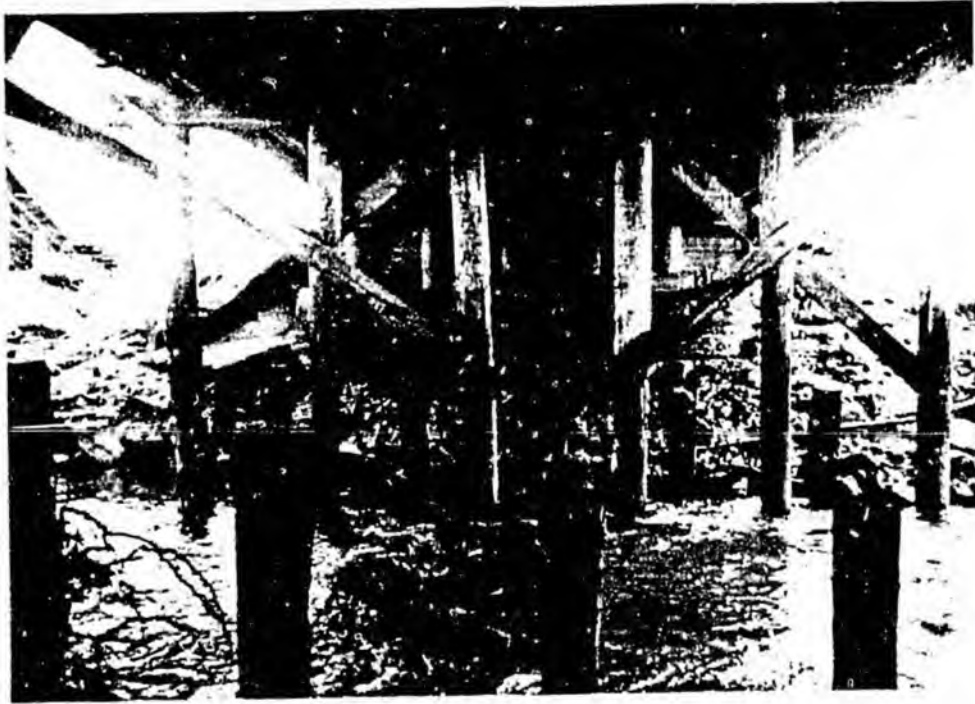

FIRST PIER FROM THE SOUTH ABUTMENT. NOTE ABRASION ON FIRST PILE AND DEGRADATION OF BRACING.

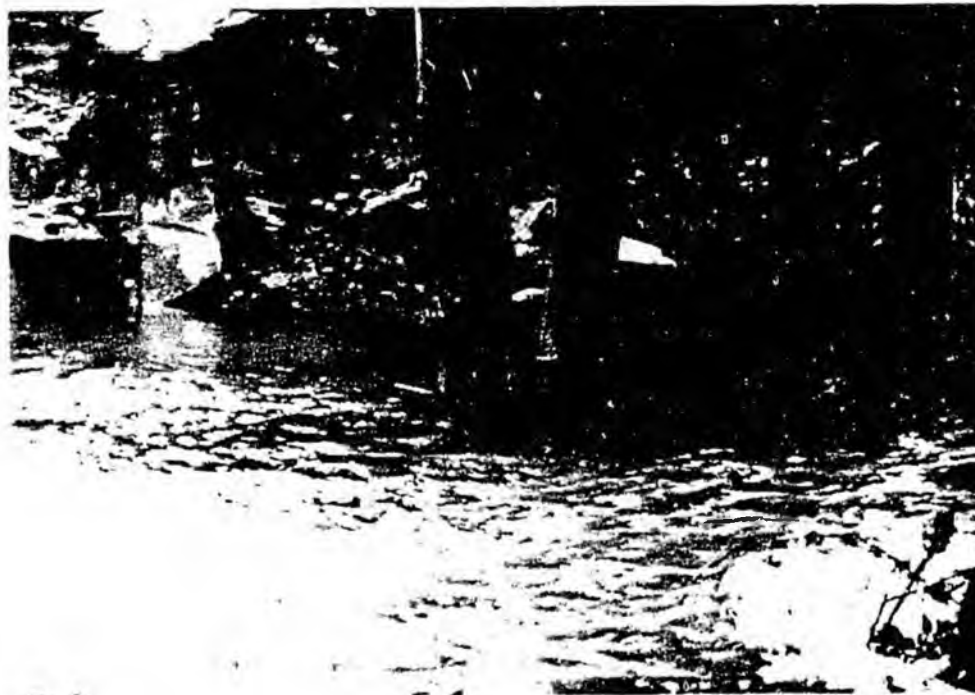

CLOSE-UP OF FIRST PILE SHOWING ABRASION.



OVERALL VIEW OF BRIDGE LOOKING NORTHWEST.



SOUTH END OF BRIDGE. NOTE WATER FLOWS TOWARD ABUTMENT.

# Railroad to give land for 'townsite' project

## Deal will hinge on \$2.1 million from state for road improvements

By BECKY NORSWORTHY  
Times Business Writer

The Alaska Railroad has agreed to turn over Government Hill greenbelt property to the municipality for a Ship Creek "original townsite" project if the Alaska legislature funds \$2.1 million in road and bridge improvements for the area, according to railroad spokesman Larry Houle.

The agreement, signed by the railroad, Glacier Brewery and the Anchorage Economic Development Corp., could lead to \$8 million to \$7 million in construction beginning next summer if the funding is approved, said AEDC president Scott Hawkins.

The agreement commits the railroad to develop the district and amenities and Glacier Brewery to develop a "brew-pub," with the AEDC working to obtain the state funds.

The AEDC feels "very, very confident" that its efforts to get approval for the state funds will be successful this legislative session, Hawkins said.

Houle, director of real estate for the railroad, said the greenbelt land involved is a minimum of 25 acres and includes the buffer between the Government Hill residential area and the industrial railroad yards, as well as the land on which the Anchorage Cu-

rling Club sits.

"This might be the first sign of the railroad's move to Birchwood," Houle said.

He and Hawkins said the idea of moving the railroad yards to the Eagle River-Birchwood area has been talked about for years.

"I think what will follow is the relocation of the railroad over a 10 to 20 year time frame, and this is the first piece to that puzzle," Houle said.

Houle said the west bluff involved in the agreement is clearly defined, but the east bluff has yet to be defined because of planned railroad track expansion.

Under the agreement, the land would be leased to the municipality at a nominal cost for 35 years with an option for an additional 35 years.

Houle said a waterfront development in Spokane, Wash., is being used as "somewhat of a model" for the Anchorage project.

He said Hawkins and railroad vice president Marv Yetter travelled to Spokane recently to see that development.

Hawkins said legislators representing downtown Anchorage are in favor of the development, that senate and house leaders are supportive and



Scott Hawkins  
... 'very, very confident'

that the Anchorage Assembly has listed the Original Townsite project second to Alyeska resort infrastructure in its economic development requests for the 1990 legislative session.

"I think there are some real long-range implications to the thing," Hawkins said. "What you've got now is an unattractive, almost run-down warehouse district."

However, he said, "It's got tremendous development potential for tourism."

"I see this as just the first step in

redeveloping that area down there to a different purpose and eventually leading to the move of the railyards," Hawkins said.

Mark Wilson, one of the principals in Glacier Brewery, said the company is "basically trying to extend the rebirth of Fourth Avenue, the turn-of-the-century theme, down through the railroad terminal area and through the (salmon) viewing area at Ship Creek dam."

The brewery's plans are to build a large brewery building for producing several different kinds of beer as well as root beer. The building will contain a gift shop and will have a "turn-of-the-century drug store atmosphere," Wilson said.

A restaurant and pub would be upstairs, overlooking the inlet and the fishing area on Ship Creek, he said.

Two trolleys, each costing about \$160,000, will carry about 30 passengers at a time to downtown hotels, along a trolley trail planned to eventually connect with the Coastal Trail, he said.

The trolleys, which look like San Francisco trolleys on tires, will be like those now being used successfully in Los Angeles and Laguna Beach, Calif., Wilson said.

The brewery will give wooden nickels to be used as tokens, he said.

The theme for the entire project is "decidedly Alaskan," Wilson said.

# Phase 1 of Ship Creek design completed

By TODD BENSMAN  
Times Writer

An Anchorage engineering firm has completed six months of design and engineering work on the first project in a plan to transform the industrial area of lower Ship Creek into a tourist district.

The \$50,000 study, the first phase of the project, commissioned last summer by the Anchorage Assembly has produced images of a stylized, turn-of-the-century foot bridge spanning Ship Creek near the city's original townsite. Along with the design, the planning firm USKH was asked to develop cost estimates and construction specifications the city will need to sell the idea to the Alaska legislature this session.

City officials said the bridge will be a key element in a master plan to turn the Alaska Railroad's yards into a waterfront

tourist center by attracting businesses to the region. The bridge itself would be a gathering point for visitors to watch salmon leap up fish ladders on their way upstream.

The Glacier Brewery Co. and other businesses interested in leasing nearby plots in the historic downtown railyard are counting on the bridge, said John Cowdry, special projects director for the city's public works department.

"It's just the start of a whole lot of things," Cowdry said. "It would be a major drawing card. If we get funding, that bridge could be completed next year."

The city could build the 275-foot bridge for a minimum of \$274,000 but could nearly double that cost with optional features, according to the USKH study.

For \$550,000, the city could build a top-of-the-line bridge complete with ornamental iron-

work, 19th-century lamps and wind shelters, but funding decisions are up to the legislature.

Improving and extending roads, and building picnic areas throughout the area to prepare it for the development would amount to another estimated \$1.5 million. The assembly has placed the \$2.1 million request for the project near the top of its legislative wish list.

"This one will go," said Assembly Chairwoman Heather Flynn. "It's very tourist-related, and the legislators are very into that right now. Everyone wants to be on the side of creating more jobs."

City lawmakers, private investors and Alaska Railroad officials for years have envisioned transforming the area between the power plant and the C Street bridge into a grassy waterfront park. The gateway would be lined with walkways, shops,

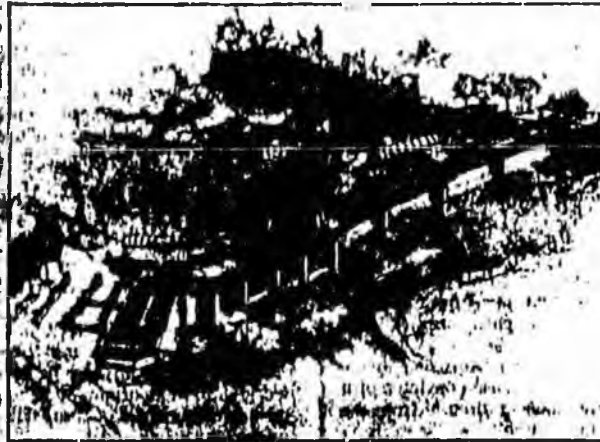

and historical monuments with the bridge as a focal point. The area already is popular with fishermen and sightseers who like to take advantage of one

funded this session, but some warned lawmakers will be looking to tighten state purse strings.

Rep. Kay Brown, D-Anchorage, said the legislature will have to grapple with controlling spending this year but predicted the first phase of the Ship Creek redevelopment would be funded.

"There are always things that need to be worked out," Brown said. "But I think the legislature sees that it has a role to play in developing the economic infrastructure of our cities, especially since we can know Prudhoe (Bay oil production) can't last forever."

"We need to focus on the industries that make (economic development) happen," she added.

Mark Wilson, president of an Alaska vodka distillery, plans to build a brewery on the south side of the creek near the bridge. Wilson said the city's willingness to

See Creek, page B-3

## Creek: Phase 1 completed

spend \$50,000 on the research and design phase was the signal his group needed to take the project seriously. He said the investors could begin construction some time next year if state lawmakers respond favorably.

"But until the state funds kick in, we can't write any checks," he said. "As long as we are given

reasonable expectations, we can move ahead."

Plans for the brewery include guided tours, a soda fountain and gift shops and would become an integral part of the project's first phase, he said.

Larry Houle, who heads the Alaska Railroad's real estate division, said the railroad wants to

relocate its freight shed depot and other structures so it can make the most of the land.

While the state-owned railroad is willing to help facilitate development on its land, it shouldn't be expected to pay for the realignment of roads or develop amenities like the greenbelt, Houle said.

# THE ORIGINAL TOWNSITE STUDY



**Prepared for The Alaska Railroad Corporation**  
**and The Glacier Brewery**  
**by BCV Architects**  
**November 1989**

**BCV  
Architects Inc.**

3301 C Street Anchorage, Alaska 99503 Phone (907) 563-1942  
Architecture Landscape Architecture Planning Fax (907) 561-6847

November 27, 1989

To Whom It May Concern,

Attached please find a current copy of the narrative and graphic materials prepared for the Original Townsite Study. The study was originally commissioned by the Alaska Railroad and the Glacier Brewery to support efforts of the Anchorage Economic Development Corporation intended to develop new business opportunities in the Ship Creek area.

The conceptual planning presented in these materials offers a broad array of new opportunities for businesses and other organizations. At the time of this printing, discussion with several important groups is in progress, and their input will continue to revise the final content of the study. Preparation of a masterplan will coordinate additional input with the basic concept represented here. The masterplan will be supported by covenants addressing land use as well as physical improvements.

Due to the probability of revisions to these materials, this copy is offered for your information only. The Railroad reserves the right to make all public announcements and presentations of this material.

If you have any questions or comments I would appreciate your call.

Very truly yours,

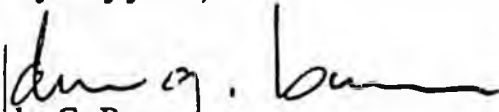
  
John G. Burns  
Principal

JGB/ah

Attachments

## CONTENTS

INTRODUCTION Page 1

DEVELOPMENT SUMMARY Page 2

EXISTING AND PROPOSED CONDITIONS Page 4

### FIGURES:

1. Site Plan - Central District
2. Sections
3. Pedestrian Bridge Plan & Elevations

## INTRODUCTION

Anchorage has long recognized the importance of the Ship Creek basin. Since the city's beginnings on the banks of the creek as a construction camp, Ship Creek has played a key role in Anchorage's development. The center of the city's industry and shipping, Ship Creek is now being examined for its potential contribution to Anchorage's premier growth industries: tourism and recreation. Recent studies by the Municipality, including the Ship Creek Greenbelt Study (Department of Economic Development and Planning, 1988), the Ship Creek Concept Plan (Port of Anchorage, 1988) and the Phase 3 Coastal Trail Design Study Report (Capital Projects Office, 1987) have focused on the recreation and tourism potential of lower Ship Creek. With its proximity to the cruise ship dock; the Alaska Railroad Passenger Depot, Downtown Anchorage, and the trail network, Ship Creek is in a unique location to support the growth of tourism. Much of the Ship Creek basin is under-utilized and is ready for a transition.

The Glacier Brewery development has provided the catalyst for a new look at the lower Ship Creek area between the Chugach Electric Association dam and the Ship Creek Waterfront. The property throughout this area is substantially owned by the Alaska Railroad. Zoning is I-2, making all anticipated uses permissible. Other than the margins of the creek itself, the area contains no significant wetlands.

A wide variety of uses are envisioned ranging from light industrial to commercial/retail and public open space and recreation. Glacier Brewery itself is planned to be a public place for both tourists and residents, with opportunities not only for touring the facility but also for shopping, socializing, and dining. This area of Ship Creek with the dam and fish ladder is already a successful destination for tourists and residents in spite of its location in the heart of the industrial area.

The current studies seek to address the larger issues of access and development potential, as well as define the types of improvements which could be anticipated to enhance the Brewery Site and its surroundings. These issues have been coordinated with the Waterfront Task Force and short range plans for the Port. The Municipal Department of Economic Development & Planning has reflected this study in new land-use maps for the Ship Creek area.

### References:

- Waterfront Task Force, 1989
- Ship Creek Waterfront -  
Port of Anchorage, 1988
- Ship Creek Greenbelt -  
Economic Development & Planning,  
1988
- Coastal Trail -  
Design Study Report,  
Capital Projects Office, 1987

## DEVELOPMENT SUMMARY

The first phase of development will include the Glacier Brewery facility with parking, the extension of Warehouse Avenue to North C Street, the bicycle and bus lanes along Ship Creek, sidewalks, the Chugach Electric Association Dam Bridge, and Fisherman's Trail. Planned amenities include street trees, pedestrian-scale street lamps, benches, bicycle racks, signs, and trash receptacles. Later phases will include additional parking, the realignment of North C Street, the extension of Warehouse Avenue to Ship Creek Point Waterfront Development, and the Christensen/Alaska Railroad overpass.

### **Chugach Electric Dam Bridge**

A bicycle and pedestrian bridge crossing Ship Creek is proposed at the presently unused Chugach Electric Association dam. The bridge will be a steel and wood structure, utilizing the existing dam for a foundation. Platforms will be incorporated in the bridge for those who wish to view salmon and waterfowl. In the interest of public safety, bus and auto parking will be eliminated from Whitney Road with its heavy truck traffic. Parking will be provided at the south end of the bridge. Figure 3 shows current design for the bridge accommodating shelters for the overlook platforms.

### **Fisherman's Trail**

Because of the popularity of Ship Creek for both viewing salmon and fishing, a "fisherman's trail" is incorporated in the project. Completing the loop begun by the Chugach Electric Dam Bridge and the south bank pedestrian and bicycle trail, the fisherman's trail will cross the creek on the existing C Street bridge structure after removal of pavement. Platforms may be added to the bridge to facilitate viewing and fishing. An unpaved foot trail will follow the north bank of the creek. To permit access to the creek, the trail will be lower in elevation

than the bicycle trail. Because of this elevation, portions of the fisherman's trail may be flooded by extreme high tides. The trail will be screened from Whitney Road by transplanted groves of native birch. Parking will be provided at the south end of both bridges.

### **Coastal Trail**

The long range plan for the Coastal Trail has anticipated connection with the proposed Ship Creek Greenbelt Trail. The Ship Creek Waterfront development has presented the opportunity to make that connection more directly if the waterfront is accessed by a grade separated crossing of Warehouse Avenue and the Alaska Railroad. Such a crossing would permit the trail to cross here and also connect to the 2nd Avenue Trail via of Christensen Drive. From the railroad crossing, the trail would follow the south bank of Ship Creek eastward, intersecting North C Street and entering the Original Townsite development. Through the Original Townsite, the trail is designed as a 12 foot wide road for bicycles with a separate sidewalk for pedestrians. At the east end of the Original Townsite Development, the Chugach Electric Dam Bridge will carry the trail across Ship Creek where it will connect with the proposed Ship Creek Greenbelt Trail.

### **Historic Buildings**

Several Alaska Railroad buildings of historical interest may be moved to the Original Townsite Development from other locations in the Ship Creek Basin. The first project anticipated would renovate a freight depot to use as a public market building for activities such as the Farmer's Market. The historic character imparted upon the district by these buildings will be further reinforced by period street lamps, benches and other furnishings, and by careful design of new buildings such as the Glacier Brewery.

### **Passenger Train Yard**

The planned alignment of the Warehouse Avenue extension permits retention of the yards developed for use by the excursion passenger trains. The passenger trains add visual interest, and are a significant reminder of the area's railroad heritage. Continuously changing displays of railroad equipment could also be accommodated here. If desirable in the future, two or more of these tracks could be removed to create more lease space on the south side of Warehouse Avenue.

### **Bus and Bicycle Lanes**

A doubledecker bus or rubber-tired street car is proposed to carry passengers between the brewery, the Ship Creek Waterfront, and downtown. Transit shelters are proposed for several locations. The lane fronting the lease parcels will be for the exclusive use of the buses. The curving lane following the creek bank will be for the exclusive use of bicyclists.

## EXISTING AND PROPOSED CONDITIONS

### Seismic Hazards

This area is in both moderate and high ground failure susceptibility zones. The area north of Warehouse Avenue extension is predominantly moderate. By contrast the general downtown area is in high to very high risk zones. Source: Geotechnical Hazard Assessment Study, 1979, Harding-Lawson Associates.

Proposed Condition: Construction will be governed by current regulations pertaining to seismic hazard.

### Flood Hazards

Nearly the entire study area is mapped in the 100 year floodway. Flood profiles indicate the area is susceptible to 10 year and 50 year flooding also. Areas above twenty feet in elevation are relatively free from flood hazard. The study area is primarily 18 to 19 feet in elevation. Source: Flood Insurance Study, 1987, Federal Emergency Management Agency.

Proposed Condition: All major development, except the Fisherman's Trail, will be placed on fill to the twenty foot elevation.

### Wetlands Classification

Downstream from the Chugach Electric Association dam, the banks of Ship Creek are classified conservation wetlands. Above the dam portions of the streambank are classified preservation wetlands. Except for a small conservation wetland west of North C Street, the remainder of the study area is classified upland. Source: Anchorage Wetlands Management Plan, 1982, Municipality of Anchorage Department of Community Planning.

Proposed Condition: Wetlands will be preserved as required, and where possible will be enhanced.

### Utilities

Existing utilities are for the most part confined to Warehouse Avenue and First Avenue.

Proposed Condition: Easement for future extension of utilities along Warehouse Avenue west to Ship Creek Point.

### Access Routes

#### **North C Street**

Multiple railroad crossings, hazardous intersection at Whitney Road, low load capacity of bridge.

Proposed Condition: Consolidate railroad crossings, realign north end with Ocean Dock Road, replace bridge.

#### **Warehouse Avenue**

Dead ends at rail yard, poor vehicular access and circulation.

Proposed Condition: Extend west to North C Street and further west to Ship Creek Point to create primary eastbound route.

#### **First Avenue**

Truck parking in street creates severe congestion.

Proposed condition: Extension of Warehouse Avenue will give through traffic an alternate route.

#### **E Street/Buttress Road**

Most direct access from downtown is limited by one way traffic designation and multiple railroad crossings.

Proposed Condition: Designate for two way traffic at least as far south as Third Avenue.

### Ship Creek Point

The existing access to the Ship Creek Point development involves several on-grade crossings of rail lines and utilizes the Anchorage Water and Wastewater Utility culvert crossing of Ship Creek Which is failing due to vehicular-loading.

Proposed Condition: Access for Ship Creek Point should be grade separated from the rail lines. Extension of Warehouse Avenue west utilizing a fill ramp and short span is an economical solution. Ramps may be extended to connect with Christensen Drive for direct access downtown.

### Christensen Drive

Good access from downtown is limited by width and curves, failing retaining wall. Existing elevation above railroad tracks offers good potential for separated crossing to Ship Creek Waterfront Development.

Proposed Condition: Replace retaining wall and straighten First Avenue to improve access to the Freightway Warehouse area. Create a combined ramp and fill access road to the Ship Creek Waterfront.

### Existing and Proposed Lease Areas

Existing leases within the study area total approximately 550,000 square feet, plus the Tour Alaska/Westours yard. Lease area under the proposed master plan totals approximately 650,000 square feet, plus the Tour Alaska/Westours yard. The yard area (H) is approximately 150,000 square feet. A diversity of lease area sizes has been provided.

Parcels between Warehouse Avenue and Ship Creek east of North C Street are approximately 1/2 block deep and are intended for small commercial and retail use. Larger parcels are provided west of North C Street. These are approximately one block in size and are intended for larger commercial or light industrial use. Space for circulation and parking has been set aside separately from the lease areas. If lease areas I,K,L and M were combined with the circulation and parking between them (area O) for one large tenant, leasable area would be increased by another 70,000 square feet.

### Summary of Proposed Lease Areas (refer to figure 2)

A	26,000 square feet
B	26,000 square feet
C	32,000 square feet
D	15,000 square feet
E	2,500 square feet
F	2,500 square feet
G	2,500 square feet
H	150,000 square feet
I	31,250 square feet
J	25,000 square feet
K	82,500 square feet
L	82,500 square feet
M	62,500 square feet
N	262,500 square feet
O	<u>72,000 square feet</u>
	875,250 square feet

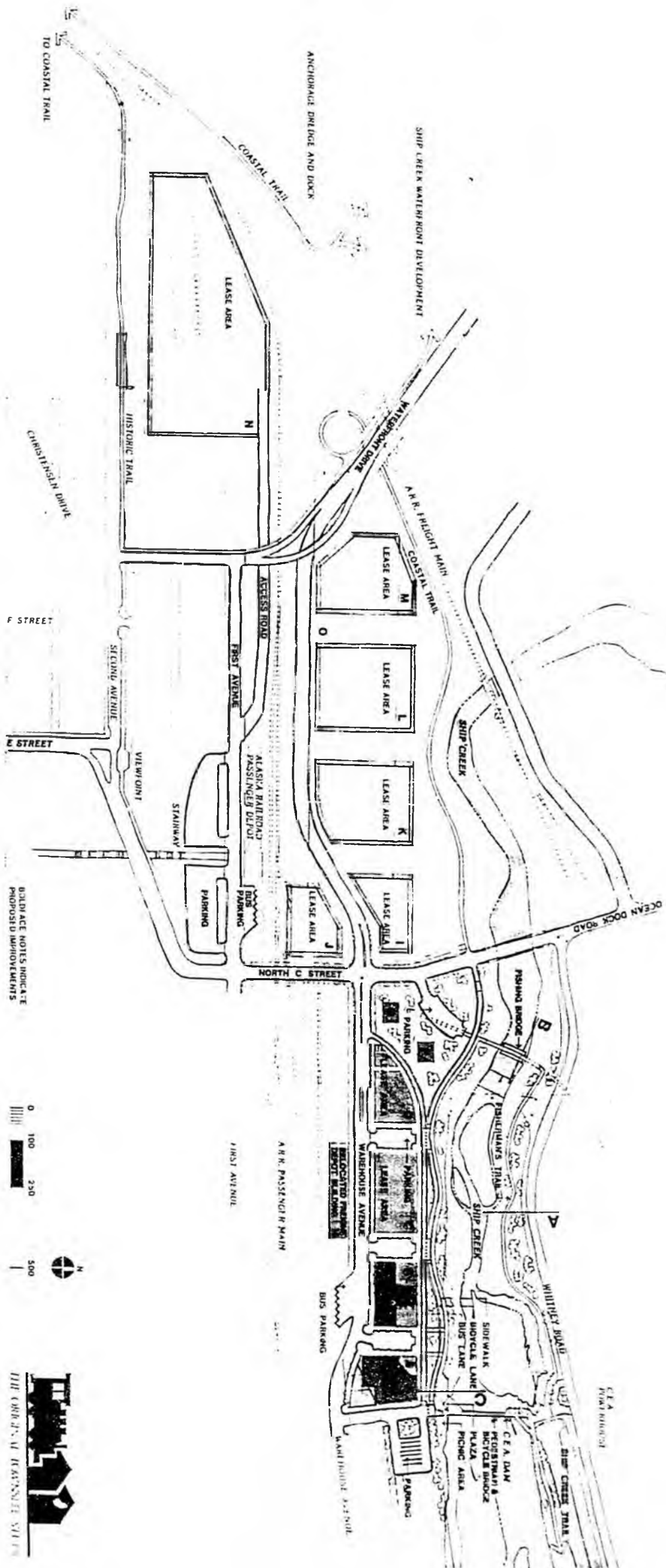

BUILDING NOTES INDICATE PROPOSED IMPROVEMENTS

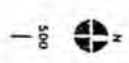

FIGURE 2



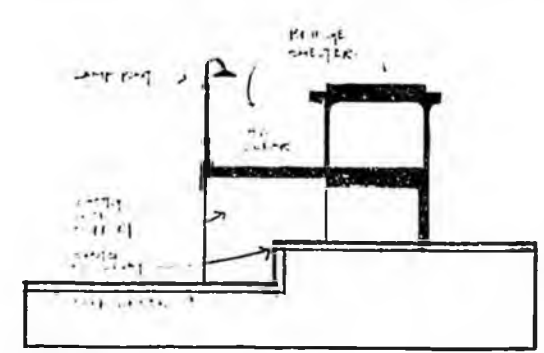
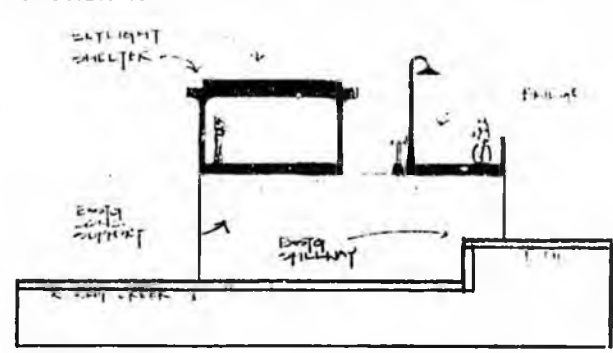
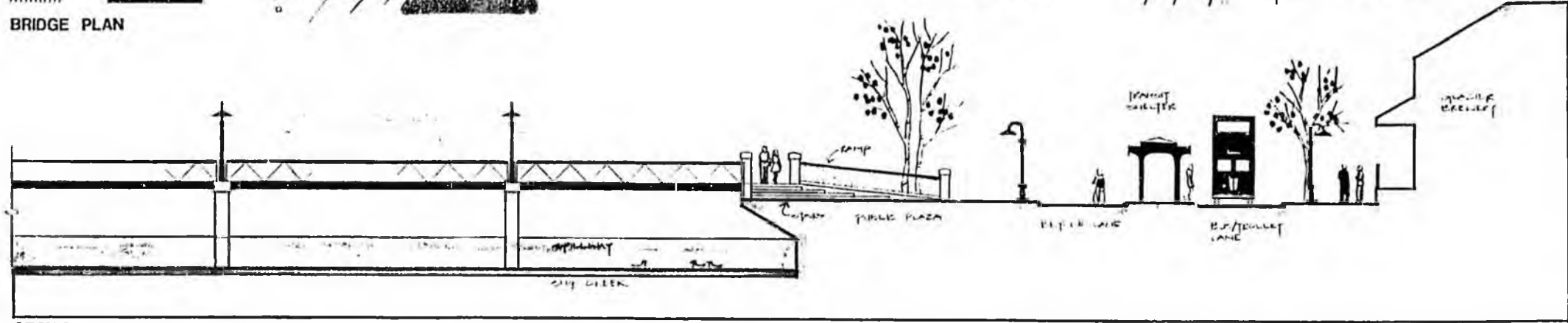
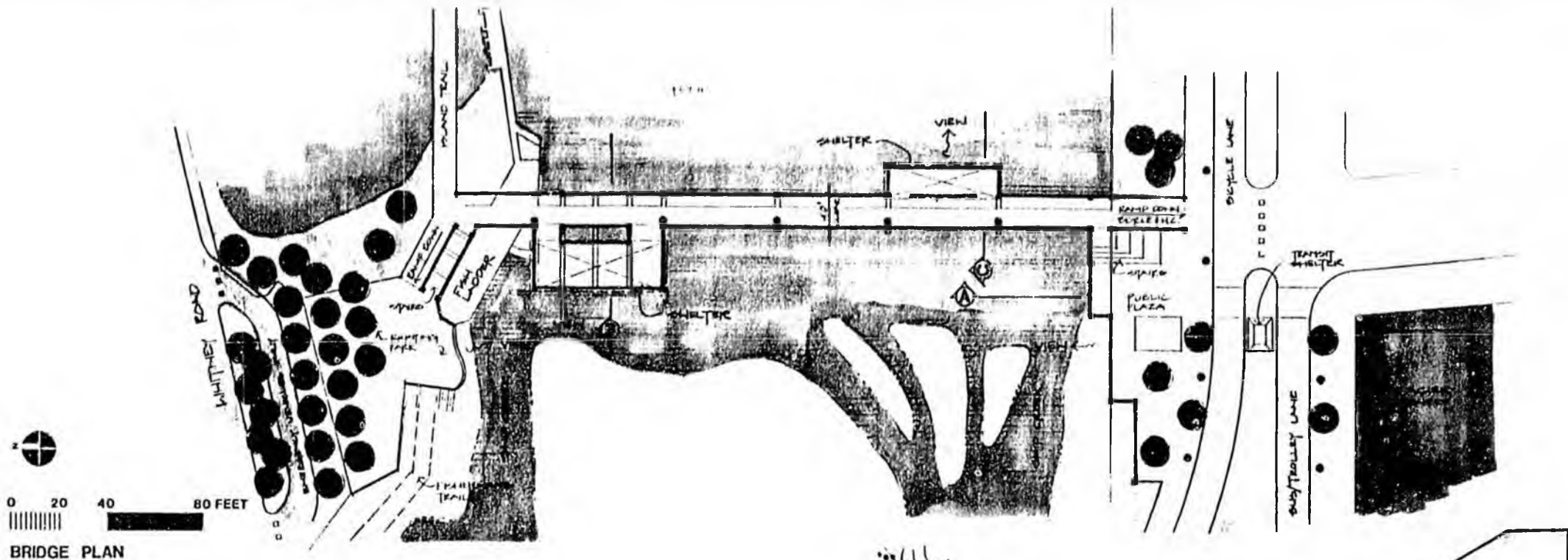
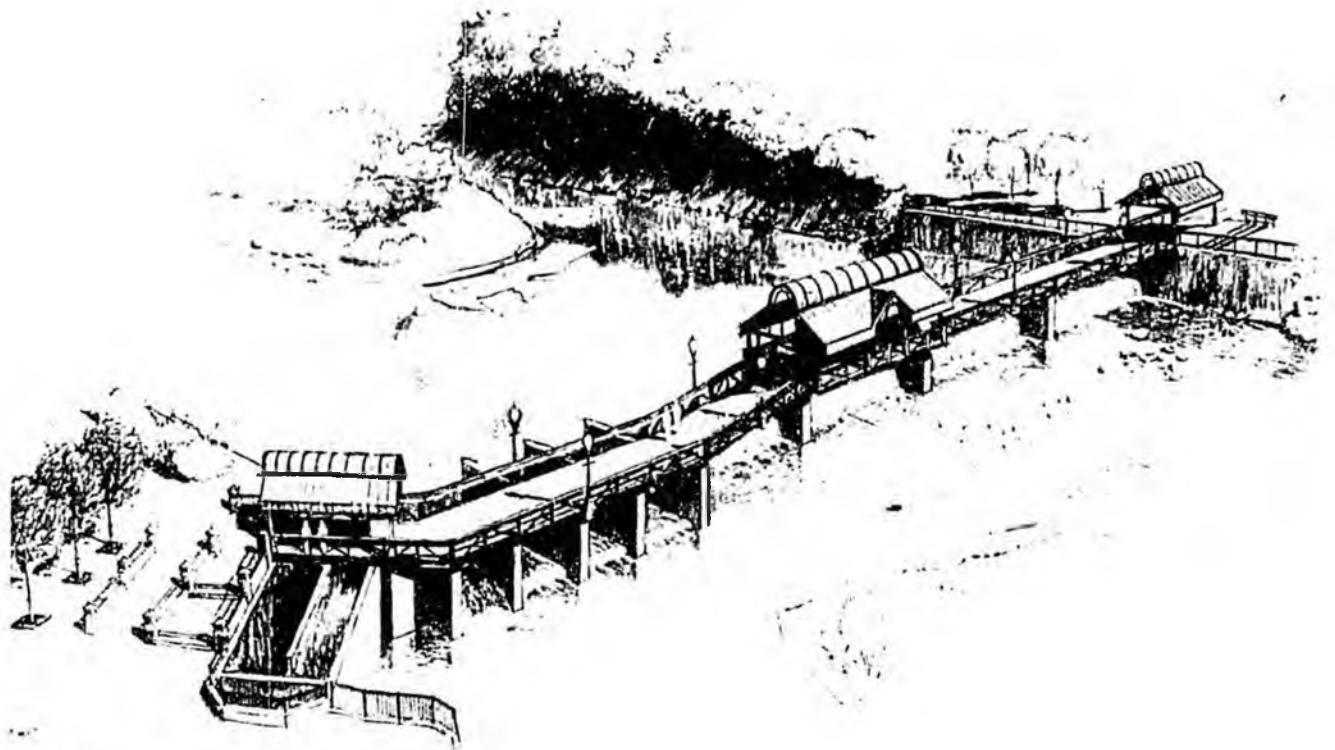

FIGURE 3

# Ship Creek Pedestrian Crossing Study



Prepared for  
The Municipality of Anchorage  
by

**USKH**

Architecture • Engineering  
Land Surveying • Planning

## TABLE OF CONTENTS

Introduction	Page 1
History/Background	Page 1
Purpose	Page 1
Executive Summary	Page 2
Design Objectives	Page 2
Design Solutions	Page 3
Existing Conditions and Recommended Action	Page 4
Architectural Theme	Page 4
Conceptual Cost Estimate - Summary	Page 5
Conceptual Cost Estimate - Detailed	Page 6
<b>FIGURES</b>	
Proposed Development Plan Ship Creek Basin	Figure 1
Aerial Perspective	Figure 2
Option 1 - Plan	Figure 3
Option 2 - Plan	Figure 4
Bridge Entry	Figure 5

DECEMBER 1989

## INTRODUCTION

The city of Anchorage began along the banks of Ship Creek as a construction camp during the development of the Alaska Railroad between Seward and Fairbanks. Over the years, as the city grew and developed over the higher ground to the south, the Ship Creek Basin remained the heart of the Alaska Railroad. With the inclusion of the Port of Anchorage and its dock facilities, this area continued to grow as the city's industry and shipping center. The increased use of the Port of Anchorage as a destination for cruise ships demonstrated the tourism potential for the Ship Creek Basin, particularly along the waterfront. The Port of Anchorage, the Alaska Railroad Passenger Depot, and the close proximity to downtown Anchorage provide three areas of activity which support the future development of this area. However, much of the Ship Creek Basin is under utilized and ready for a transition.

## HISTORY/BACKGROUND

In early 1988 the Alaska Railroad commissioned the Architectural and Planning firm of BCV Architects to study the development potential of the Ship Creek Basin and to prepare a Master Plan. This Master Plan entitled The Original Townsite Study was completed in December of 1988. Several developments were sited in the final study. Among them was the Glacier Brewery along the south side of Ship Creek. The brewery and adjacent development would provide the catalyst to bring a new look to the Ship Creek Basin between the old Chugach Powerplant Dam and Ship Creek Point. The Master Plan Development Summary is as follows:

The first phase of development would include the Glacier Brewery facility with parking, extension of Warehouse Avenue to north of "C" Street, the bicycle and bus lanes along Ship Creek, sidewalks, the Chugach Electric Association dam bridge, plazas, and the fishermen's trail. Planned amenities include street trees, pedestrian scale street lamps, benches, bicycle racks, signs, and trash receptacles. The fishing bridge may be included in the first phase of the development with the understanding that the Alaska Railroad needs to keep it operational for emergency use. Later phases would include additional parking, the realignment of north "C" Street, the extension of Warehouse Avenue to Ship Creek waterfront development, and the Christenson/Alaska Railroad crossing.

The Master Plan developed by BCV Architects was presented to numerous interested groups in Anchorage. A presentation was made to the Ship Creek Basin Task Force which is comprised of several interested private and public entities. A series of meetings between the Municipality of Anchorage and the Alaska Railroad were held concerning this study and it was agreed that the Municipality would fund further design studies for major components of the Master Plan. In September of 1989, the Municipality of Anchorage retained the Architectural and Engineering firm of USKH, Architects and Engineers, to further develop some of the key elements of the Master Plan. USKH was asked to prepare schematic design and cost estimates to construct the pedestrian bridge to cross Ship Creek utilizing the existing Chugach powerplant cooling pond dam. (USKH was also to look at the realignment of north "C" Street and evaluate the existing "C" Street/Ship Creek bridge crossing. The "C" Street realignment study and the bridge evaluation is described in a separate report prepared by USKH entitled North "C" Street Concept/Feasibility Study dated December 1989.)

## PURPOSE

The purpose of this study is to review further the feasibility of constructing a pedestrian bridge across the Chugach Powerplant Cooling Pond Dam. The following is to be addressed:

1. Evaluate the structural capacity of the existing steel structure which runs across the top of the concrete dam and supports abandoned steam lines and some electrical conduit from the old powerplant.
2. Meet with interested parties for their input into the pedestrian crossing design.
3. Design a pedestrian bridge across the cooling pond dam.

4. Develop a Cost Estimate for the pedestrian bridge.
5. Develop a conceptual style appropriate to the area based on The Original Townsite Study.
6. Present the bridge design to various interested parties, groups, boards, and commissions.
7. Produce a report suitable to further advance the cause for the bridge construction.

## EXECUTIVE SUMMARY

After analysis of the existing steel structure which supports abandoned steam lines across the concrete dam, it was concluded that it would not be feasible for future bridge construction. Not only is the steel structurally inadequate to support the loads required for the pedestrian bridge, it is approximately 7 feet above the existing grade. The height problem would make it extremely difficult for handicap access.

USKH proposes a steel bridge structure with a concrete deck and an inside clear width dimension of 12 feet. This structure would be designed primarily for pedestrian traffic, but it could also accommodate bicycles, cross-country skiers, and handicap traffic. The bridge would be designed to support light vehicle traffic for snow removal and emergency ambulance service.

To provide a comfortable viewing area of the salmon run in Ship Creek and other natural scenic views, USKH incorporated three roof structures over portions of the bridge. These will serve as an entrance gate to the bridge, a central viewing area at the mid-point of Ship Creek, and another viewing area over the existing fish ladders to allow people full utilization of the facility during inclement weather. An attempt has also been made to extend the use of this facility in the spring and fall for the tourist. However, there is no funding for these shelters at the present time.

It was the strong recommendation of the Alaska Railroad and Glacier Brewery that the pedestrian bridge crossing structure be recognized as having two functions. One function would be to provide a means for pedestrians to cross Ship Creek. It also would serve as a tourist attraction to draw people from the downtown hotel district. The bridge would engage the Master Plan and pull tourist and resident alike to the Ship Creek District with the proposed market area along the south shore of Ship Creek.

The proposed Architectural theme revolves around "Turn-of-the Century Railroad Architecture." This will be similar to the gas light theme currently being utilized in the renovation of 4th Avenue, and more recently developed along Spenard Road. A major accent of this theme is the use of the cast-iron ornamental elements seen on the street lamps, park benches, and at building structures. The roof structure on the bridge is patterned after railroad platform roof structures of the late 1800's and early 1900's.

The proposed budget by the Municipality of Anchorage is \$300,000 for the construction of the pedestrian bridge facility. Our estimate indicates the basic bridge and certain limited amenities could be provided for this amount. Other funding sources are available for the landscape development at either end of the bridge; these may also be available for the bridge shelters.

The schematic design of the bridge has been presented to the Alaska Railroad, Glacier Brewery, Ship Creek Task Force, the Urban Design Commission, the Planning and Zoning Commission, the Parks and Recreation Commission, Fish and Game, and the Government Hill Community Council.

## DESIGN OBJECTIVES

1. To utilize the existing Chugach Electric Association dam as a feature which would serve as part of the revitalization of the lower Ship Creek basin. The project must relate functionally and aesthetically to the existing Ship Creek overlook at the north end of the dam and to the proposed Glacier Brewery Site at the south end.

2. Create a pedestrian/bicycle crossing of Ship Creek linking the Coastal Trail system to the proposed Ship Creek Greenbelt Trail.
3. Provide areas for viewing of scenery, waterfowl and salmon. Improve exposure of the existing fish ladder to allow an improved view of the salmon run by the public.

## DESIGN SOLUTIONS

The concrete piers which are part of the existing CEA dam will serve as the foundation for the new bridge. The bridge will have an open web steel truss structure with wood or concrete decking. The total length will be roughly 275 feet, with each truss spanning 45 to 50 feet between concrete piers. A 12 foot clear width is proposed to accommodate both pedestrians and bicycle traffic. In addition, the bridge should have sufficient width and strength to support an emergency vehicle (i.e., ambulance) and small snow removal equipment.

The bridge has been designed with the top chord of the truss acting as the guardrail and the bottom chord resting on top of the existing concrete piers. This places the walking/riding surface at the lowest possible elevation, creating a minimum amount of ramping at the bridge entrances. This arrangement also allows generous clearance under the bridge for floating debris. A tight weave wire screening will be placed in the voids between truss members to establish a legal guardrail.

All areas of the bridge, including entrances, will be handicap accessible.

Two options for the bridge are being presented

**Option 1** - This design includes the features that would truly meet the design objectives. A widened portion is provided near center-span. This would serve as a viewing platform and as a means of stepping out of the flow of traffic. Also, in Option 1 shelters are provided at both ends of the bridge and at the center-span viewing platform. These shelters will be a steel tube framework with metal roofs and ornamental ironwork at each gable end. A row of barrel-shaped plexiglas skylights are planned at the ridge of each shelter roof. Pendant light fixtures mounted from the ceiling of the shelters will create a dramatic nighttime effect as they illuminate the skylights from within. Ornamental lamp posts similar to those found on Spenard Road will cross the bridge in this option.

The shelters at the north and south ends act as "entry portals" to the bridge. Also, the north end shelter spans over the existing fish ladder providing a direct view into the fish ladder.

The design of the bridge is such that at a later date the shelters could be extended to abut one another thus covering the entire bridge.

**Option 2** - This option is the more economical version of the two. Structurally it is the same as Option 1 and maintains the 12 foot clear width. Option 2 has no widened viewing platform or sheltered areas, although it would be possible to construct Option 2 first then add the covered shelters or other amenities at a later date.

## EXISTING CONDITIONS AND RECOMMENDED ACTION

### 1. Utilities and Structures

**Existing** Abandoned steam lines and electrical conduit run along the top of the dam for its entire length. They are supported by a steel truss framework.

**Recommendation** Remove steam lines, electrical conduit and steel truss framework. The steel trusses were considered as a possible support system for the new bridge but were found to be too light for the additional loads and too narrow for a pedestrian/bicycle crossing.

### 2. Fish Ladder

**Existing** Fish ladder at north end of dam, access is restricted by 8' steel fence.

**Recommendation** Increase exposure of fish ladder by repositioning and reducing height of surrounding fence. Provide see thru cover over fish ladder to prevent tampering with fish.

### 3. Floodgates and Valves

**Existing** Floodgates at north end of dam are used by Fish & Game personnel to control water level for fish attraction through ladder.

**Recommendation** Floodgates and valves to remain operable and in place. This necessitates a jog in the alignment of the new bridge to avoid the floodgate control valves. This jog becomes an advantage for several other reasons. First it moves pedestrians closer to the concentration of fish entering the ladder. Secondly it causes the bridge to cross directly over the fish ladder improving viewing.

## ARCHITECTURAL THEME

With input from interested parties, including the Alaska Railroad, Glacier Brewery, Municipality of Anchorage and the Ship Creek Task Force, an architectural theme which reflects a "turn of the century, gaslight style" was agreed upon for the project.

The bridge expresses this style through the use of ornamental ironwork, filigree, exposed structural members and connections, ornamental lamp posts and lighted bollards.

These elements are also reminiscent of the early railway station loading platforms. Indeed, the bridge's design could also fall into the category of "railway architecture." This is a strong allusion to the Ship Creek area's history as a rail center. This "gaslight" style also relates well to other developed themes in Anchorage including the 4th Avenue area and the recent improvements along Spenard Road.

The architecture of the bridge will set the tone for future projects in the area and should be carried on throughout the revitalization of the Ship Creek basin.

CONCEPTUAL COST ESTIMATE - SUMMARY

	Estimated Cost Including Contingency
<b>Option 2</b>	
Basic Bridge with concrete decking and standard handrail.	\$274,438
<b>Option 1</b>	
Basic Bridge	\$274,438
Wire Screening	\$38,676
Lights	\$53,151
Shelter - South	\$46,293
Shelter - North	\$48,379
Shelter - Midspan	\$89,364
	<b>TOTAL \$550,301</b>
Savings if wood deck is used	\$9,051

# SHIP CREEK PEDESTRIAN BRIDGE

## Conceptual Cost Estimate

9

***CLARK-GRAVES, INC.***

Anchorage, Alaska  
(907) 337-2767

**Prepared for:**

USKH, INC.  
2515 A Street  
Anchorage, Alaska 99503  
(907) 276-4245

