

ALASKA LEGISLATURE COMMITTEE FILES 1983-1984

2991

HSA SB 227

2991

ANALYSIS OF PUBLIC NEED

Limited Analysis

The following evaluations of the Council's activities relate to the public need factors defined in the "sunset" law. These evaluations are not intended to be all inclusive, but address those areas we covered in our review.

- I. The extent to which the board, commission or program has operated in the public interest.
 - A. The Council has promoted high standards in the research it has funded.
 - B. The Council has made an attempt to inform the public about new technologies and scientific advances through support of symposiums and conferences in Alaska.
 - C. The Council has been involved in developing an arctic research policy culminating in a bill before the United States Congress.
 - D. The Council has identified various research needs of Alaska and attempted to bring these needs before the public.

- II. The extent to which the operation of the board, commission, or agency program has been impeded or enhanced by existing statutes, procedures, and practices which it has adopted, and any other matter, including budgetary, resource, and personal matters.
 - A. The Council has been impeded in performing its statutory duties by the absence of any condition requiring State agencies and the University of Alaska to report to the Council concerning research funded or performed.

- III. The extent to which the board, commission or agency has recommended statutory changes which are generally of benefit to the public interest.
 - A. The Council has contributed to public discussions in an attempt to develop an Alaskan science policy which could lead to a more coordinated research program in Alaska.
 - B. The Council has assisted the Office of the Governor in development of an Alaskan position on the future of the Naval Arctic Research Laboratory. The fundamental Alaskan position was

to seek a federal/state partnership in both use and financing.

- IV. The extent to which the board, commission, or agency has encouraged interested persons to report to it concerning the effects of its regulations and decisions on the effectiveness of services, economy of services, and availability of services which it has provided.
- A. The Council has developed a peer review committee of scientists and technicians who review and comment on research proposals submitted to the Council. This has promoted high research standards in the research funded by the Council.
- V. The extent to which the board, commission or agency has encouraged public participation in the making of its regulations and decisions.
- A. The Council has made extensive use of the public in determining the research needs of Alaska. Scientists and technicians in government, education, and private industry have participated in workshops to discuss research needs. Various research needs reports have evolved from these meetings.
- B. The Council encourages public participation in its discussions by public announcement of its meetings.
- C. The Council participates in the Alaska Science Conference held each year in Fairbanks. Questions and comments concerning the Council and its function are solicited from interested parties.
- VI. The efficiency with which public inquires or complaints regarding the activities of the board, commission or agency filed with it, with the department to which a board or commission is administratively assigned, or with the Office of the Ombudsman have been processed and resolved.
- A. We found no instances where the Council did not respond to public inquires.
- B. We found three complaints handled by the Office of the Ombudsman. Each was resolved efficiently and to the satisfaction of the complainant. The Council implemented the recommendations of the Ombudsman.

- VII. The extent to which the board or commission which regulates entry into an occupation or profession has presented qualified applicants to serve the public.
- A. The Council does not have a licensing function.
- VIII. The extent to which State personnel practices, including affirmative action requirements, have been complied with by the board, commission or agency to its own activities and the area of activity or interest.
- A. We found no problems in this area.
- IX. The extent to which statutory, regulatory, budgeting, or other changes are necessary to enable the agency, board, or commission to better serve the interests of the public and to comply with the factors enumerated in this subsection.

Please refer to the previous section, Findings and Recommendations.

APPENDIXES

APPENDIX A

ALASKA COUNCIL ON
SCIENCE AND TECHNOLOGY FY'83
Summary of Questionnaires

Questionnaires were sent to 165 persons to obtain information about the Council from the public. All names were systematically chosen from a list of peer reviewers provided by the Council and from participants in the Council workshops on research needs. We received 70 responses to our questionnaires. All but eight responses were from the original persons contacted. Many of the responses included thoughtful written comments. Due to space limitations, comments had to be shortened, and many could not be included.

	Private Sector			Federal Government			Research Institutions			State Government			Total		
	Yes	No	Unknown	Yes	No	Unknown	Yes	No	Unknown	Yes	No	Unknown	Yes	No	Unknown
1. Have you had any contact with the Council on Science and Technology?	11	2	0	21	0	0	17	0	0	15	4	0	64	6	0
													91%	9%	0%
If no, please make any comments you may have in the space provided at the end of this survey.															
2. The Council has the obligation to reduce duplicative research funded by the State. Do you feel the Council has been effective in meeting this goal?	6	1	1	12	0	5	10	3	3	7	5	3	35	9	12
													63%	16%	21%

If yes, please explain.

1. Attempt to guarantee monies they allocate are wisely spent.
2. Meetings help researchers get acquainted with each others activities.
3. Research needs reports.
4. Has reduced duplication with their own funds but this is a small portion of State funded research.
5. The Council has reduced duplication through their peer review committee.
6. Council emphasis on avoidance of duplication.

If no, how could they become more effective?

1. More information to the public and to scientists.
2. More level centralization of all research.
3. More time.
4. More than lipservice from State research agencies.

(Continued on next page).

	Private Sector			Federal Government			Research Institutions			State Government			Total		
	Yes	No	Unknown	Yes	No	Unknown	Yes	No	Unknown	Yes	No	Unknown	Yes	No	Unknown
5. Surveyed opinions on water resource needs but this survey was in itself duplicative of similar tasks by other agencies.															
6. Monitor all research for validity, quality.															
7. Need power to review and pass judgement on all funding.															
3. Are you aware of any instances where planned research was not funded because the Council advised that the information was already available?	1	10	0	3	14	1	4	12	0	0	15	1	8	51	2
													13%	84%	3%
4. Do you believe the Council has been successful in bringing the scientific and technological community into closer contact with State policy makers?	9	1	1	13	1	14	1	1	1	9	4	1	45	9	4
													78%	15%	7%
5. Are you aware of the research needs identified by the Council as priorities within Alaska?	8	3	0	18	3	0	14	1	1	8	9	0	48	16	1
													74%	25%	1%
If yes, do you feel they are relevant to State needs?															
1. Not only are they relevant, but they should be used by the Legislature and the agencies in the budget process.															
2. They have very successfully outlined State needs in certain areas.															
3. Yes, very much so, however, I also believe that scientific needs don't coincide with policies and doubt that needed work will be funded without the usual political games.															
6. Do you feel the Council has influenced public policy on scientific issues facing the State?	4	3	3	7	5	8	9	4	4	3	6	3	23	18	18
													38%	31%	31%

Please explain.

1. Not in business long enough.
2. Has brought research needs before policy makers.
3. Has not received needed publicity.
4. Arctic Research Policy.
5. Council is a candle in the darkness.
6. Threats to shut the Council's Offices have led to some instability, uncertainty and loss of confidence.

(Continued on next page).

	Private Sector			Federal Government			Research Institutions			State Government			Total		
	Yes	No	Unknown	Yes	No	Unknown	Yes	No	Unknown	Yes	No	Unknown	Yes	No	Unknown
7. Do you feel it is government's responsibility to promote scientific and technological inquiry?	13	0	0	21	0	0	16	0	0	14	2	0	64	2	0
													94%	6%	0%
8. If this program were eliminated what effect, if any, would it have on your agency, institution, company, or the public interest?															
1. State funding would be lost.															
2. The idea is good, should not be eliminated.															
3. Would lose valuable vehicle for those in research to bring forward research topics, also raises the quality of research.															
4. State government could lose its easy access to scientists.															
5. Coordination of state and federal research would suffer resulting in more potential for duplication.															
6. Loss of broad view of research needs.															
7. Would lose peer review committee															
8. ACST guided research to topics relevant to Alaska - if not continued research maybe less relevant.															
9. Vested interests too often get funded for "research" that has no relevance. ACST should have greater advisory status.															
10. Fourteen responses stated there would be little or no effect.															
9. Are there other organizations in the State performing the same duties?	2	5	1	1	18	2	2	12	1	7	5	3	12	40	7
													20%	68%	12%
Please list if yes.															
1. Appropriate Technology.															
2. Nearly every agency, school has research functions and policy roles.															
3. Department of Fish and Game.															
4. Geological and Geophysical Survey.															
5. Arctic Environment and Information Data Center.															
6. University of Alaska direct department budget funding.															
7. Many of the Council's tasks are duplicative of work done by other agencies.															
8. Individual agencies: APA, APEC, APUC, Dept. of Admin., Division of Telecommunications.															

(Continued on next page).

	<u>Private Sector</u>			<u>Federal Government</u>			<u>Research Institutions</u>			<u>State Government</u>			<u>Total</u>		
	Yes	No	Unknown	Yes	No	Unknown	Yes	No	Unknown	Yes	No	Unknown	Yes	No	Unknown
10. Do you believe there is a public need for this program?	11	0	0	21	0	0	16	0	0	12	3	1	60	3	1
													94%	5%	1%

Please explain.

1. ACST is a vehicle by which structured communication can flow back and forth between the technical and scientific community and the executive branch of government.
2. State needs to establish priorities.
3. Need a coherent program to define needs and priorities and to account publicly for them.
4. Make public aware of lack of information.
5. Need a statewide focal point for coordination of research efforts. I believe this role should be strengthened.
6. Reduce duplication (effective).
7. Provides a unique Alaska emphasis with more direct feed back to management agencies.
8. Need a coordinating mechanism for use of State funds.
9. Coordination provides more effective research.
10. The need is for an organization in state government to fund and promote research.
11. Needs tenure to be effective.

11. Any other comments?

Private Sector

1. Impressed by foresight in planning and implementation of the Council Connection to public policy is appropriately distant. If ties were too close the quality of science might greatly diminish.
2. Few ideas from Northern Technology available to the public.
3. Very high level reviews of proposals were obtained by donation of time, knowledge and experience by scientists in Alaska - at very low cost.

(Continued on next page).

4. I am concerned about the tone of this questionnaire. It seems to have missed the point on most important issues. I don't think ACST has been useful so far but the idea needs to be encouraged and the Council upgraded and given authority to be creative and useful - good idea badly handled.
5. Provides unbiased research - perhaps need an Alaska Science Foundation.
6. More funds for more research.
7. Need more publicity.

Federal Government

1. More publicity.
2. I was quite puzzled over what ACST was receiving for the overhead charge of 50% from the University of Alaska. Would like an itemization of overhead charges. In my opinion the Council's policy of not doing so could lead to misuse of public funds.
3. Needs to be better funded.
4. Council is to be commended on the development of the peer review process.
5. Public needs someone to ensure that only relevant, broad-reaching research is funded.
6. ACST should institute a policy of not funding agencies outside the State if qualified and prepared agencies within the State are ready to do the work.

Research Institutions

1. As a very active researcher on policy issues in Alaska, I see a strong need for ACST.
2. More publicity
3. Needs more funding. It is a relatively low cost program which has great potential. Needs to mature in procedures and priorities.
4. Council provides a scientifically sophisticated mentor for Alaskan decision makers.
5. The State has shown considerable wisdom in setting up the Council.
6. Budget should be increased by \$5,000,000 so they can effectively carry out the funding for Alaskan research problems.

(Continued on next page).

State Government

1. Should be similar to the National Science Foundation.
2. Must be assured existence for seven years.
3. The existence of this body is important but must have a breadth of knowledge about on-going research Statewide to make meaningful decisions.
4. Need a cleaning house activity to control and restrict duplicative research and to monitor overall quality of funded projects.
5. My impression is that ACST's advice was virtually ignored by the Legislature and Executive. Media reported on the grants program, otherwise it didn't seem to accomplish much.
6. Alaska could well profit from a carefully designed long range program of research and development in limited areas.
7. ACST has not had sufficient support to achieve its true potential as a policy guidance tool.
8. Can provide focus on research needs and a forum for exchange.
9. Publish a list of on-going projects and projects under consideration.

APPENDIX B

ALASKA COUNCIL ON
SCIENCE AND TECHNOLOGY
APPROPRIATIONS COMPARED
WITH EXPENDITURES

For the Fiscal Years 1982 and 1981
UNAUDITED

	<u>1981-1982</u>		<u>1980-1981</u>	
	<u>Authorizations</u>	<u>Expenditures</u>	<u>Authorizations</u>	<u>Expenditures</u>
<u>Operating Programs</u>				
<u>General Government</u>				
Alaska Council on Science and Technology (operations)	<u>\$ 603,000</u>	<u>\$ 544,000</u>	<u>\$479,200</u>	<u>\$475,652</u>
<u>Capital Programs</u>				
<u>General Government</u>				
Alaska Council on Science and Technology (grants)	<u>2,500,000</u>	<u>972,000</u>	<u>300,000</u>	<u>28,845</u>
	<u><u>\$3,103,000</u></u>	<u><u>\$1,516,000</u></u>	<u><u>\$779,200</u></u>	<u><u>\$504,497</u></u>

Expenditures include encumbrances and are reported on a budgetary basis.
Amounts are per books.

(Intentionally left blank)



THE ALASKA COUNCIL ON SCIENCE AND TECHNOLOGY

February 2, 1983

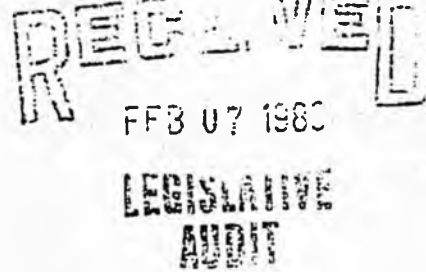

Mr. Gerald L. Wilkerson, CPA
Legislative Auditor
Division of Legislative Audit
Pouch W
Juneau, Alaska 99811

Dear Mr. Wilkerson:

This responds to your letter of January 17, 1983 enclosing a copy of "A Performance Report on the Department of Administration, Alaska Council on Science and Technology, December 1, 1982."

There are many errors and misconceptions in your report. These we discussed in our letter of November 30, 1982 and personally in your office on January 11, 1983.

The following summarizes our position on your report.

1. From the title of your report you imply that the Council is a line organization of the Department of Administration. This is not true; the legislative record is clear that the Council's affiliation with the Department of Administration is for administrative "house-keeping" purposes only.
2. The Council rejects your assertion that the legislative intent associated with its statutory establishment and duties was to coordinate and centralize research information. We believe a number of legislators and administrative personnel associated with the Council's establishment and operation can testify to this matter.
3. The Council asserts that it has functionally defined Alaska research needs. That these statements are currently valid and offer priorities by research function or field (i.e., Transportation, Minerals, Natural Hazards, Agriculture and Animal Husbandry, Health and Human Life, Communications, etc.). The Council rejects your assertion that it is charged with the prioritization of research across a spectrum of Alaskan societal concerns. Such prioritization can only be done by policy makers in the executive and legislative branches; and properly so.

Comments on many of the details of your report are contained in our letter of November 30, 1982. The Council reaffirms the content of that letter, rather than to repeat its substance here, since there are clearly

Mr. Gerald L. Wilkerson
February 2, 1983
Page Two

basic differences of opinion between your office and the Council on a number of matters. These differences we view as honest questions of interpretation and here express our appreciation for the professional and courteous manner in which your staff conducted its analysis of Council affairs.

Sincerely,

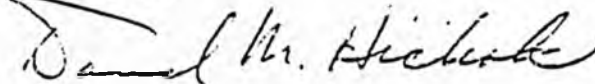

David M. Hickok
Chairman

DMH:pb

cc: L. Rudd, Commissioner, Department of Administration
C. Noah, Executive Director, ACST

Alaska State Legislature



RECEIVED
MAR 7 1983

Speaker of the House of Representatives

Pouch V
State Capitol
Juneau, Alaska 99811
(907) 465-3720

Official Business

March 7, 1983

TO: Rep. Mitch Abood
Chairman, State Affairs Committee

FROM: Joe L. Hayes
SPEAKER OF THE HOUSE *JLH*

SUBJECT: Sunset Legislation: Alaska Council on
Science and Technology

Attached is the audit report prepared by the Office of Legislative Budget and Audit for the Alaska Council on Science and Technology for review by your committee. Normal procedure is for the responsible committee to initiate legislation extending the life of the agency to a specified date, then if the Legislature elects to sunset it, the bill will either be defeated or allowed to die.

STATE OF ALASKA

AUDIT DIVISION
POUCH W
JUNEAU, ALASKA 99811

THE LEGISLATURE

BUDGET AND AUDIT COMMITTEE

MAR 04 1983

March 3, 1983

TO: Honorable Joe L. Hayes
Speaker
House of Representatives

FROM: Representative Bob Bettisworth
Chairman
Legislative Budget and Audit Committee

SUBJECT: Forwarding of Sunset Audits

Enclosed are the remaining two sunset audit reports of Boards and Commissioners that will terminate June 30, 1983. They include the Alaska Council on Science and Technology and the Alcoholic Beverage Control Board. I am forwarding these reports to you so that they may be distributed to the appropriate standing committees you will designate to perform the legislative oversight function.

E

SMOKE DETECTOR TESTING

IN

RURAL ALASKA

**Alaska Council on Science and Technology
Fire Safety Task Force**

**Research Funded
by the
Alaska Department of Public Safety
and the Alaska Council on Science and Technology**

May 1982

Dear Reader:

The Alaska Council on Science and Technology is pleased to offer this report, *Smoke Detector Testing in Rural Alaska*. It results from an inceptive effort in cooperative problem-solving research in Alaska. The Alaska Department of Public Safety, concerned over rural fire safety and early detection, wanted to implement a program of smoke detector installations in the homes of rural, village Alaska. The problem was to determine the type of smoke detector best suited to the rural situation. Mr. James Messick, special assistant to the Commission of Public Safety, approached the council for help in this determination. The council assembled a volunteer task force of fire safety specialists, scientists, engineers, and other knowledgeable individuals to evaluate research results and report on them.

This report represents the findings of the resulting one-year study of equipment and attitudes. It contains much valuable information and provided needed data for the Department of Public Safety. We hope that this work is instrumental in improving fire safety in rural Alaska.

The Office of the Vice Chancellor for Research and Advanced Study, University of Alaska, Fairbanks designed and administered the research program in cooperation with the Department of Public Safety through their Village Public Safety Offices Program.

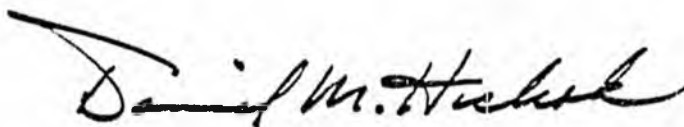

David M. Hickok
Chairman

Abstract

Residential fires are an extreme hazard in Alaska, particularly in rural areas where fire protection services are minimal to nonexistent. To address this problem the Alaska Department of Public Safety contracted the Alaska Council on Science and Technology to research the feasibility of, and best procedures for, implementing effective use of smoke detectors in rural residences. No particular type of detector or manufacturer was a standout choice of the individuals participating in this study. This was due to individual attitudes, and it appears that attitude will govern the effectiveness of a widespread program to install smoke detectors in rural Alaska homes. The Fire Safety Task Force recommends that the smoke detector portion of the fire safety program emphasize education and instruction of villagers.

TABLE OF CONTENTS

Introduction	1
Method	1
Data and Results	3
Discussion of Results	7
Conclusions and Recommendations	9

Figures	13
---------------	----

Appendices

A Background Information (available on request from ACST)	23
B Questionnaire	25
C Final Questionnaire	27
D Village Coordinators' Instructions	29
E Householder Instructions	35
F Householder's Log	37
G Monthly Visit Form	39
H Silencer Circuit	41

INTRODUCTION

Residential fires cause more deaths (per capita) in Alaska than in any other state. The safety hazard is particularly acute in the rural villages, which experience five times more residential fires than do Alaska metropolitan areas. To address this problem the Alaska Department of Public Safety planned to purchase smoke detectors to provide an early warning device for village homes. No empirical data existed on the types of smoke detectors that would function best in small, often one-room, houses. Therefore, the department contracted the Alaska Council on Science and Technology (ACST) to research the feasibility of, and best procedures for, implementing effective use of smoke detectors in rural residences. The ACST appointed the Fire Safety Task Force to design and implement the research program. A list of the members and affiliations of the task force follows.

William Hao, Fire Inspector, City of Fairbanks Fire Department and Governor's Task Force on Fire Prevention and Control

David Mather, Director, Health Department, Tanana Chiefs Conference

James Messick (ex-officio), Alaska State Troopers

Gerald Romick, Professor of Geophysics, Geophysical Institute, University of Alaska

William Shechter, Fire Chief, University of Alaska

Nancy Smoyer, Project Coordinator, University of Alaska

The task force developed a program to test several different brands of two basic types of smoke detectors to determine the best unit. Laboratory tests on detector sensitivity were performed both before and after field installation.

Rural houses in Alaska are typically 400-to-600-sq ft structures of log or frame construction with one main living area. Small bedrooms are built off to the side and are often separated from the main room by only a drape. The houses are usually heated by wood- or oil-burning stoves located in the main room. Cooking often takes place in the main living area.

A preliminary background study (Appendix A) on smoke detectors indicated several problems to be investigated to find the best smoke detector for rural Alaska homes and lifestyles. Two main types of smoke detectors are manufactured for home use—ionization and photoelectric detectors. Ionization detectors were expected to respond more quickly to cooking fumes, thus resulting in frequent false alarms. Exposure of either type of detector to unusually high or low temperatures could cause excessive battery drain or the alarm to go off as the temperature changed. Other potential problems included blowing dust and dirt built up by cooking and heating fumes and smoke.

METHOD

The Fire Safety Task Force was a temporary group formed by the ACST to direct and conduct the detector research program. Members of the group included faculty of the University of Alaska and representatives of the University of Alaska and City of Fairbanks fire departments, Tanana Chiefs Conference, Governor's Task Force on Fire Prevention and Control, and Alaska State Troopers. During the course of the project the task force met approximately 16 times to

design, implement, and evaluate the program. The task force decided on a research program that included both laboratory calibration and field testing of smoke detectors.

A total of six villages in coastal and interior areas served as field test sites. Galena, Tanana, and Fort Yukon were chosen as the interior villages; Nome, Shishmaref, and Teller as the coastal villages. Five households in each village tested three smoke detectors for a total of 90 smoke detectors field tested. Models and quantities of the detectors tested are shown below.

Type	Manufacturer	Model No.	Number Tested
Photoelectric	BRK	2000	18
Photoelectric	Chloride Pyrotector	30-77A	21
Photoelectric	Electro Signal Labs	912	21
Ionization	BRK	79R	10
Ionization	General Electric	8201-401	15
Ionization	Guardion	FB-1A	5

For each installation three detectors were mounted approximately three inches apart on a board, and the boards were distributed so that every village had a reasonable number of samples of each kind of detector. Only detectors using 9-volt alkaline batteries were used because of the unreliability of electricity in most villages. The sensitivity of the detectors was tested in a smoke box prior to installation and retested on completion of the project. A device to silence false alarms for a 10-minute period was installed in the detectors (Appendix A). In three villages this device was activated at installation; in the other three villages the silencing devices were hooked up at the discretion of assistants living in the villages (village coordinators), depending on the attitude of the householder to the false alarms.

Additional funding of \$5,000 to test the silencer adaptation was obtained from the ACST Northern Technology Small Grants Program after the task force determined that such a device was necessary to relieve the householders of the many anticipated false alarms. Another \$5,000 grant was similarly obtained to test the reaction of the detectors to the extremely cold and changing temperatures which could cause problems peculiar to rural Alaska homes. This latter program is still in progress.

The testing period began in mid-April 1981 and was projected to last six months, with a possible two-month extension into the winter months. An interim visit to the field test sites was made by the project coordinator after three months to troubleshoot problems and to evaluate the progress of the project with the use of a questionnaire (Appendix B). One village dropped out of the project at the end of the initial six-month period, and four elected to continue for two more months. (One other village, Fort Yukon, dropped out in June.) In December the project coordinator collected the smoke detectors from the villages. At the same time, a final questionnaire (Appendix C) was used to evaluate the performance of the smoke detectors and the attitude of the householders toward each type.

The village coordinator functioned as the contact between the villagers and the Fire Safety Task Force in Fairbanks. The Tanana Chiefs conference assisted in choosing the coordinators for the three interior villages. Village public safety officers acted as village coordinators for the two coastal villages. The Alaska State Troopers in Nome provided extensive and effective logistical

and escort support. Instructions for the village coordinators (Appendix D) and householders (Appendix E) were drawn up, as were logs for the village coordinators and householders to complete and send back to Fairbanks monthly. The Householder's Log (Appendix F) provided a record of false alarms including the date, time, cause, and silencing method. The village coordinators' Monthly Visit Log (Appendix G) recorded the results of their monthly visits, e.g., the status of the smoke detectors and the attitude of the householders. The village coordinators and householders each received a monthly payment upon receipt of their reports.

The test houses varied but had several characteristics in common relative to fire protection. Almost without exception there were no bedroom doors; curtains were often hung in the doorways. There was little stuffed furniture (particularly on the coast) which would be susceptible to smoldering fires. Beds, however, were often used as furniture. Oil was the primary heating source on the coast. Wood burning stoves were available as back up in six of the 15 houses. Fourteen of the 15 houses in the Interior used wood-burning stoves as the primary heat source.

In Teller two new one-bedroom Alaska State Housing Authority (ASHA) homes and three old houses, one of which was a large two-story house, were used. Four houses with very small living areas (approximately 12 x 16 feet) were utilized in Nome. Two of these houses had bedrooms off the main room and numerous occupants (5 and 9) and visitors. The fifth house in Nome was a larger, new, frame house with a peaked roof.

In Shishmaref the detectors were tested in two one-bedroom houses. One of these was a very small (12 x 20 feet) one-room house, and the other somewhat larger with three rooms. One house was quite large (24 x 28 feet) and had three cooking and heating sources.

In the Interior three-quarters of the homes were log, unlike the coast where there was none of logs. In Fort Yukon the living areas of three houses was approximately 12 x 18 feet with one or two connecting bedrooms. (The other two householders in Fort Yukon dropped out of the program almost immediately.)

One of the houses in Galena was a large two-story combination frame and log house with two heat sources and six occupants. Also, two very small frame houses were used—one with one room and one occupant and the other with two rooms and two occupants. Both had wood and oil heating sources. The remaining two houses had log with wood-burning stoves as the only heat sources.

Two smoke detector boards were removed from houses in Tanana after a short period. One was never reinstalled, but the other was placed in a house with a small living area (12 x 20 feet) and five occupants. The remaining three houses were all medium size (approximately 18 x 20-foot living area with several bedrooms). All burned wood for heat, and all had numerous occupants (4, 6, and 7).

Approximately 75% of all the householders had prior knowledge of or experience with smoke detectors. One man, who was very fire conscious, had already installed several smoke detectors, including one he made himself. In the ACSHA and federal-program housing on the coast, smoke detectors had been installed when built and almost without exception been disconnected, whether battery or electric.

DATA AND RESULTS

The results of this study can be divided into two categories: detector performance and people's attitudes. The performance data were compiled from householder monthly logs and from laboratory testing of the detectors. The attitudinal data were gathered from the three periodic questionnaires and from general observations made throughout the project and, more specifically, during the visits to the villages.

The monthly reports from the householders of incidences of false alarms produced mixed results. In spite of efforts to insure reliable reporting, the inherent problems of human fallability resulted in erratic or unreliable reporting from at least 10 householders, particularly near the end of the test period. Also, a problem with low battery signals, which became evident almost immediately after installation of the detectors, decreased the usefulness of some of the data from the first three months.

Faulty C-MOS chips used as a part of the silencer adaptation (Appendix H) were found unexpectedly to be drawing power from the battery, thus causing many of the detectors to emit the sound that the device emits to signal low batteries. The resulting confusion and annoyance among the householders and village coordinators caused three householders to have the detector boards removed and some of the others to lose confidence in the detectors. This battery drainage problem was resolved in early July by cutting the silencer wire on 30 of the detectors during the interim visits by the project coordinator. At least four of the detectors were accidentally deactivated during this process. Eight boards were brought back to Fairbanks to replace the chips with a different kind; but only three of these boards were returned to the villages. (Fort Yukon dropped out of the program completely at this time.) Although some of the householders continued to change batteries quite often after the silencer deactivation, the monthly logs and village coordinator comments indicated far fewer low-battery signal occurrences.

The responses of householders to the silencer adaptation were varied. In addition to the original 15 houses equipped with silencers, only one was hooked up later. Although many people liked the idea of the silencer in principle, very few seemed to use it, usually because they needed a longer silencing period than the 10 minutes the silencer provided. They usually found it easier to remove the battery during the smoke-producing periods rather than repeatedly pushing the silencer button. Of the 15 householders who had a silencer from the beginning of the program, five of the 10 families who wanted a detector at the end opted for a silencer. Two of the other five families who were told about the possibility of a silencer wanted one.

An phenomenon revealed in the monthly reports and investigated during visits by the project coordinator was short single beeps of unidentified origin. These beeps were reported by at least eight householders, primarily in interior villages during summer. The beeps seemed to abate in the latter months of the testing period and were no longer reported as a serious problem. Although several causes of these beeps were hypothesized, including bugs, dust, low or high humidity, a bad chip, cosmic rays, and static electricity, nothing could be proved. New unidentified beeps in the colder months were probably due to the change in temperature. At least four householders related the cooling off of their houses to these alarms.

The performance or operational data of each smoke detector was obtained from the householder logs, which were designed to incorporate enough information to determine the cause of an alarm. The data from the logs on the number of alarms for each month were summed onto another form and sorted by detector model and village.

The total number of alarms, regardless of cause, was plotted for each detector model over the eight-month period to try to detect any systematic differences between the detectors. Figure 1 shows this plot normalized to the number of detectors of each type producing the alarms. No significant differences between the three photoelectric models were evident. The ionization detectors scored higher overall incidence of alarms, and the GE unit alarmed consistently more than either the BRK or Guardian models.

Because of problems with the silencer circuits and some detectors themselves, it was necessary to determine whether the statistics were biased for or against some detectors because of the actual number in service. Figure 2a shows the number of detectors of each type in operation over the test period each month, and Figure 2b shows the fraction of each detector model in operation each month. Except for the silencer problem in June (the problem was eliminated in

July), the fraction of each type in operation was similar for all models; it decreased about 30 percent during the first six months. The dropping out of another village in addition to Fort Yukon after the initial six-month period is the cause of the scatter in the data for October and November.

Figures 3a and b show the number of alarms, both known and unknown, normalized by dividing the total number of alarms by the number of detectors of each model. There appear to be more known alarms for both the GE ionization and the BRK ionization detectors. The cause is due primarily to cooking. The apparent high incidence of unknown alarms from the BRK photoelectric detector in Figure 3b was caused by reports from three houses in April, May, and September and is probably not indicative of any problem with that model detector.

The impact of characteristics peculiar to each village, such as location, house type and life-style, on the number of alarms produced was investigated. Figure 4 is a plot of all alarms per village over the test period. Much of the scatter seen in the early months could be due to the silencer problem and consequent low battery alarms. No clear tendency for one village to consistently have more alarms than another village appears in the data after July. The number of alarms in certain villages was not due to the decrease in the number of detectors during the test period. The following list shows the percent of detectors in each village that operated during the entire test period.

Shishmaref	92.5%
Teller	79.2%
Galena	71.2%
Nome	69%
Tanana	65%
Fort Yukon	33%

Shishmaref had almost all of its detectors in operation for the entire test period of eight months. Fort Yukon had most of its detectors pulled out in June due to multiple problems with false alarms and the resulting high level of frustration of the householders and the village coordinator. The householders and village coordinator in Nome also opted to discontinue the program at the end of the initial six-month period. The remaining villages had similar percentages of operational detectors during the period. Thus, factors pertinent to individual village characteristics seem to play no major role in detector survivability.

The number and types of alarms with respect to various causes for houses characterized as <300 sq ft and >300 sq ft were examined (Figure 5). The square footage shown is of the main room in which the detector was located, which invariably included the kitchen. The greatest source of alarms (93%) in both room sizes was cooking activity. More cooking-related alarms occurred with ionization detectors than with photoelectric detectors. Of the remaining known alarms, approximately 40% was caused by wood-burning stoves and the others by miscellaneous factors, such as cigarette and Pic smoke. (Pic is a solid mosquito repellent that when lit repulses the pests.) There is an apparent greater incidence of alarms for both types of detectors due to heating with wood in smaller rooms compared to larger ones. However, false alarms of known cause occur more frequently in small rooms than in large ones, so room size may be the key factor. Also, there is a higher incidence of false alarms of unknown cause with photoelectric

detectors than with ionization detectors, regardless of room size. Of the total number of recorded alarms, both known and unknown, approximately 23% was unknown.

The detectors were tested for sensitivity in an adaptation of the standard UL smoke test box before distribution to the villages and after their return. Figure 6 illustrates the basic design and electrical circuit of the smoke box. A Pic coil was used to produce a uniform smoke of reproducible particle size and burning rate. The use of Pic provided another test, as many village homes use it liberally in the summer. It was important to determine how the detectors will react to this material.

Figures 7a and b give the results of the tests made on the detectors before they were installed and after their return approximately 11 months later. No cleaning or maintenance was performed on the detectors in the laboratory prior to retesting. Although there is some variation within each manufacturer's model of both types, all the detectors of a given model started out with generally the same percent obscuration per foot.* Within the scatter of the data Figure 7a shows that the average sensitivity of the photoelectric detectors changed very little if at all during this period, although the variation in sensitivity within each model increased. This increase may be due to effects of variable aging of the detector emitters (LED) or receivers as well as variation in cleanliness and collected dust. The changes of control detectors kept in the laboratory during the field test period were all within the observed standard deviation for that particular model. The sensitivity of these detectors varies from manufacturer to manufacturer (ESL 3.3%, BRK 2% and CP 1.3% obscuration per foot in this smoke box); however, all are within the 7% obscuration per foot UL limit.

Figure 7b illustrates the generally higher sensitivity of the ionization detectors (Guardion 0.3%, GE 0.5% and BRK 0.7% obscuration per foot) relative to the photoelectric detectors, at least to the smoke particles used for these tests. All of the ionization detectors had increased their sensitivity (Guardion 0.15%, GE 0.2% and BRK 0.24% obscuration per foot) by the end of the test period. Even the control detectors that were not used during the tests showed an increase in sensitivity of the same order in similar amount. Though it was not unexpected that ionization detectors increase in sensitivity due to dust accumulation, it is somewhat surprising that all makes and all detectors changed similarly. There are two possible reasons:

1. The number of small particles in the Pic used in the final tests may have been higher relative to larger particles than in the initial tests. Thus, the photoelectric detectors would experience no great change since they are primarily responsive to larger particles, whereas the ionization detectors would register more sensitivity than previously. The problem with this idea is that some ionization detectors were tested with the remains of the old batch of Pic, and they too indicate a similar higher sensitivity. Therefore, this seems an unlikely possibility.
2. Another possibility which is more alarming is that the conductivity in the reference side of the circuit due to the radioactive source is decreasing with time. This decrease in the radioactive source would act much like an increase in conductivity in the sample chamber and thus produce a higher background upon which only a small amount of smoke could trigger an alarm, thereby increasing the sensitivity of the detector.

*"Obscuration per foot" is the percent absorption of light per foot going through the atmosphere, which increases as the level of smoke increases.

DISCUSSION OF RESULTS

No clear-cut superiority of one type or model detector over another was found among those tested. Since cooking produced most of the alarms, however, any educational program should inform villagers that ionization-type detectors will sound off from cooking more often than photoelectric detectors. Although the photoelectric detectors produced more unknown alarms, this does not appear to be significant since the unknown alarms were only 23% of the total reported alarms. Also, many of these false alarms occurred in the early months and were probably due to low battery signals. The changes in sensitivity noted in our test of the two types of detectors over extended periods should be taken into consideration when determining the most reliable and effective detector for general village use. The increase in sensitivity of the ionization detectors may eventually produce a detector with such a high nuisance level that the homeowner disconnects it completely.

Perhaps the most interesting and potentially useful information gained from the study is the attitude of the householders to the smoke detectors. This seems to be the overriding factor in determining the acceptance and effectiveness of smoke detectors in village homes. The type or model of detector does not seem to be as important as the householder's feelings about fires, false alarms, and smoke detectors in general. At the end of the program three householders chose not to retain a detector; and 20 wished to keep one of the detectors. When asked which of the three detectors tested in their homes they would like to have and why, six chose the detector which had the most false alarms, seven the least, and five chose the detector with intermediate numbers of false alarms. Two chose the GE ionization detector because of the less offensive sound of the alarm it produced. Regarding the choice of detector by type, 10 people chose the ionization models (BRK-5, GE-5) and 10 the photoelectric (CP-7, BRK-3). However, within each of the four brands chosen, the reasons given were equally divided between which detectors gave the most, least, or moderate numbers of false alarms. The people who chose the detectors which sounded the most cited reasons such as, "You know it's working," "It doesn't just sit there," and "It's better to be too sensitive than not sensitive enough." Others found the sensitive alarms very annoying and preferred the less sensitive detectors. Several people chose on the basis of what they determined to be a reasonable smoke level to trigger the detector, saying, "It doesn't go off for no reason like the others" and "It went off when I opened the stove—the real thing."

In general the householders were willing to put up with a large number of genuine false alarms because of their belief in the life-saving value of the detectors. Almost all agreed that smoke detectors are good and useful. Families with children and people with prior experience with fire incidences expressed the strongest positive feelings. One woman with children said that she felt more secure with a smoke detector because it was like having "somebody else to watch for fire."

At least four people's appreciation of smoke detectors was heightened during the program because they had been warned of potential or actual fires by the test detectors. One woman in Galena was awakened by her detector alarming in response to burning cotton caulking in the stack of her wood-burning stove. Another woman in Fort Yukon was warned of a pan left on the stove while she was outside. During the first test month a man in Nome was alerted by his detectors when a relit, pot-type oil furnace flooded and overheated. A family in Galena found the false alarms so annoying that they asked that the detectors be removed at the end of the six-month period. Unfortunately, a few days later a stack fire occurred in their wood-burning stove, which persuaded them to buy a detector.

During the test period there were other unique motivational influences pertinent to the future success of a smoke detector distribution program. There were three motivational forces beyond those of the individual householders—the village coordinators, the monthly payments,

and the three visits by members of the task force. Numerous householders expressed the sentiment that they wouldn't have continued the program if it weren't for one or more of these factors.

The ambivalence of the householders to the silencer adaptation may be due to the initial problem of false alarms caused by low batteries over which the silencer had no control. As a result, some of the householders lost confidence in the effectiveness of the silencer saying, "It would be OK if it worked." It does not appear that the silencer would be worthwhile installing on a large scale. The task force recommends that a simpler solution to false alarms would be to install the detectors within reach so that the batteries could be removed during false alarm periods, thus requiring a wall-mounted model. Alternatively, a simple switch could be installed that disconnected the battery. However, neither of these suggestions would be UL approved.

Although the problem of low battery signals caused by the silencer draining the batteries was solved for the most part by cutting the wires to the silencers, the continued frequent changes of batteries could have been due to at least three factors. It is possible that the batteries were changed without provocation, as is indicated by the reduction with time of incidences of reported low battery signals. The village coordinators in at least two villages said that they changed some batteries monthly as a preventative maintenance measure even though there were no low battery alarms reported. It is also possible that the batteries were run down by frequent cooking false alarms, although, again, the number of battery changes did not necessarily seem to correlate with the frequency of false alarms. A third probable cause cited by several householders is that the lower temperatures in the homes at night reduced the battery voltage, thus producing false alarms. Therefore, the evidence indicates that battery changes in the rural homes will need to be more frequent than the one-year UL requirement. A parallel laboratory test of the effects of temperature on smoke detectors is being carried out using ACST small grant funds; the results will be reported separately.

The practicality of battery-operated detectors as compared to normal 110-v household electricity came into question because of the frequent battery changes even after the silencer wires were cut. Although electric detectors would resolve the problem of low battery signals, it is the collective opinion of the Fire Safety Task Force that battery-operated detectors are more effective for two reasons: First, installation of battery-operated detectors is much easier, particularly in existing houses, and would therefore make their distribution more widespread. Secondly, since it seems inevitable that there will be fairly frequent false alarms with any kind of detector in any kind of rural home, there must be a provision for silencing the alarm. The only quick means of disconnecting a wired-in electric detector is by destroying it (which had already happened frequently in homes where electric detectors were installed when built), whereas with a battery-operated detector the battery can simply be removed. Several of the householders seemed to find this method satisfactory, saying they removed the battery while baking or frying and then replaced it. In spite of the danger that the battery won't be replaced, the alternative of a destroyed detector is worse.

Observations and reactions by the householders and the task force to certain physical characteristics of specific models of detectors could prove useful in determining which model would be most effective. As previously stated, the reaction of the householders to the frequency of false alarms was so mixed for each model that no preference could be found. The ease with which a detector can be opened for removal of the battery during false alarms periods is crucial to detector acceptance. The detector which was easiest to open was the GE model. Its hinged cover stayed attached even while open. The two models with the pop-off tops (BRK and Guardian) were also relatively easy to operate. The ESL model which slides off its base was particularly difficult to remove because it was hard to remember whether the detector slides to the left or right, thus inviting banging it to move it. The Chloride Pyrotector model also was difficult to

open because it required aligning the detector to two runners on the base which is attached to the wall. Another problem with the CP model is that when the battery is removed the empty wires to which the battery attaches can get caught in the detector during replacement of the cover, making it nearly impossible to reopen.

The two methods of connecting the battery, a stationary terminal and a terminal attached to wires, affect the long-term effectiveness of the detectors. There is a potential for breaking the wires found in the GE, ESL, and CP models during removal and replacement of the battery. The disadvantage to the stationary terminals found in the BRK and Guardian models is that it is sometimes difficult to be sure that the battery is securely attached and will not slip out later.

CONCLUSIONS AND RECOMMENDATIONS

Although some decisions about the detectors can be made on the basis of laboratory tests and examination of householder reports, no particular type of detector or manufacturer was a standout choice of the individuals participating in this study. This lack of unanimity is due to the overpowering impact of individual attitudes. The detector that might respond only to a true fire could be unacceptable to householders because it did not go off enough for them to feel confident that it was working; others would be equally upset if the detector ever went off. Thus, it is attitude that will govern the effectiveness of a widespread program to install detectors, not the particular type or make of detector installed. The selection of one detector and its distribution will not in itself produce an effective early-warning device for the villagers.

The Fire Safety Task Force recommends that the smoke detector portion of the fire safety program emphasize education and instruction of villagers. Some specific findings of the project which would be useful to the villagers follow.

1. False alarms will almost certainly occur, perhaps frequently.
2. Ionization-type detectors will produce significantly more false alarms than photoelectric models with the indication that the number of false alarms will increase with age of the detectors.
3. Smaller rooms produce more false alarms, so the detector should be placed as far away from the cooking source as possible without losing its life-saving capability.
4. Although people's attitudes toward false alarms vary greatly, an appreciation of the life-saving value of smoke detectors can overcome objections to those alarms.

The awareness of fire danger and the life-saving value of smoke detectors was high among the householders in this study. Approximately 75% of the householders had prior experience with detectors. Other villagers may not have that interest. The village coordinators do not think that this project has had much effect in heightening the awareness of the general populace to the usefulness of smoke detectors.

The laboratory tests and householder logs led to certain conclusions about the detectors themselves, their installation and maintenance, and householder attitudes.

1. Field tests of 90 smoke detectors conducted during 1971 in six Interior and coastal Alaska villages indicate that the major problem with the use of smoke detectors in rural homes in Alaska is the occurrence of false alarms of known and unknown origin. These false alarms greatly affect the acceptance and usefulness of detectors in rural residences.

2. The attitude of the householders toward smoke detectors is more important than the choice of an ideal detector. Therefore, the education and instruction of the villagers about fires and smoke detectors is of primary importance.
3. There are no apparent village-to-village or regional differences that affect the technical operation of the smoke detectors.
4. The primary cause of known alarms is cooking (93%), and most cooking in village homes takes place in the main living area. Therefore, any detector should be located as far away from the cooking area as possible without losing its life-saving capability. To allow the householder to deactivate the detector by removing the battery during false alarm periods (which seems to be the most feasible solution):
 - a. The detector should be wall-mountable to allow easy access.
 - b. The detector should be easy to open in order to remove the battery without damage during false alarm periods. (Chloride Pyrotector and ESL detectors were particularly difficult to open.) The speed with which a householder can deactivate the alarm will determine whether the detector stays in use or not.
5. The installation of a silencer attachment to deactivate the detector for a 10-minute period, though potentially desirable, appears technically and economically unfeasible due to UL regulations. A more obvious solution to which most users resort (even those with a silencer) is to temporarily remove the battery from the detector during false alarm periods.
6. People prefer detectors which have the least irritating alarm signal. (Of the detectors tested, the chirping noise of the GE model was preferred.)
7. Persons with experience with fires are most likely to want smoke detectors in their homes.
8. A certain fraction of village householders is unlikely to retain smoke detectors in working order in their homes because of the problem of false alarms. Of those that will there is roughly equal division between those who prefer a detector which gives the least number, an intermediate number, and the highest number of false alarms.
9. Photoelectric detectors produce significantly fewer false alarms than ionization, particularly of the more frequent cooking-related alarms.
10. The sensitivity of the detectors changes over the course of the study period. Generally, ionization sensitivity increased and photoelectric sensitivity stayed constant. Increased sensitivity means more false alarms and a higher nuisance level with predictable irritation to the householders.
11. The detectors should be battery-operated rather than electric to encourage more widespread distribution and continued use.
12. Extreme temperature changes in the house may cause false alarms due to battery deterioration.

13. It will probably be necessary to change the batteries more frequently than the UL requirement of once a year.
14. Regular inspections of the detectors by the village public safety officer or other designated villager for encouragement and education of the householders will improve performance. However, the primary responsibility for the maintenance of the smoke detector should rest with the householder.
15. During the course of the test program there is no known instance of an actual incipient fire which was not warned against by any operating smoke detector. There were four or more instances of real fire warnings by detectors during the test period. Thus, on the basis of this test program and other input, the installation of smoke detectors in rural Alaska residences is a worthwhile endeavor likely to lead to reduced fire losses and fewer deaths.

With these considerations in mind the Fire Safety Task Force offers the following recommendations for the purchase and distribution of smoke detectors in rural Alaska.

1. If the Department of Public Safety wishes to pursue a fire safety program that incorporates smoke detector installations, it is imperative that major attention be given to education and instruction of the users. *The attitude of users toward the smoke detectors is more important than the choice of which detector is to be installed.* Two potential educational aides are pamphlets on smoke detectors to be prepared by a group such as the Literacy Council and public service announcements on television.
2. Regular visits by a fire safety person to inspect detectors and offer encouragement to the householders will increase the continued use of the detectors.
3. There are two categories of criteria for selection of a particular model of smoke detector—required and optional. Required characteristics include:
 - a. Photoelectric detectors because they are less susceptible to the primary cause of false alarms (cooking activities) in small, essentially one-room rural residences and are therefore least likely to be rejected by householders.
 - b. Battery-operated rather than electric.
 - c. Wall-mountable for easy access during false alarm periods.

Optional characteristics include:

- a. Less than 3% obscuration per foot level (ESL is the only model of those tested which does not meet this recommendation).
- b. Inoffensive alarm signal (such as the GE chirping sound).
- c. Battery replacement ease, e.g., a cover which is easily removable (preferably attached as with the GE model) and easily accessible battery clips or wires.

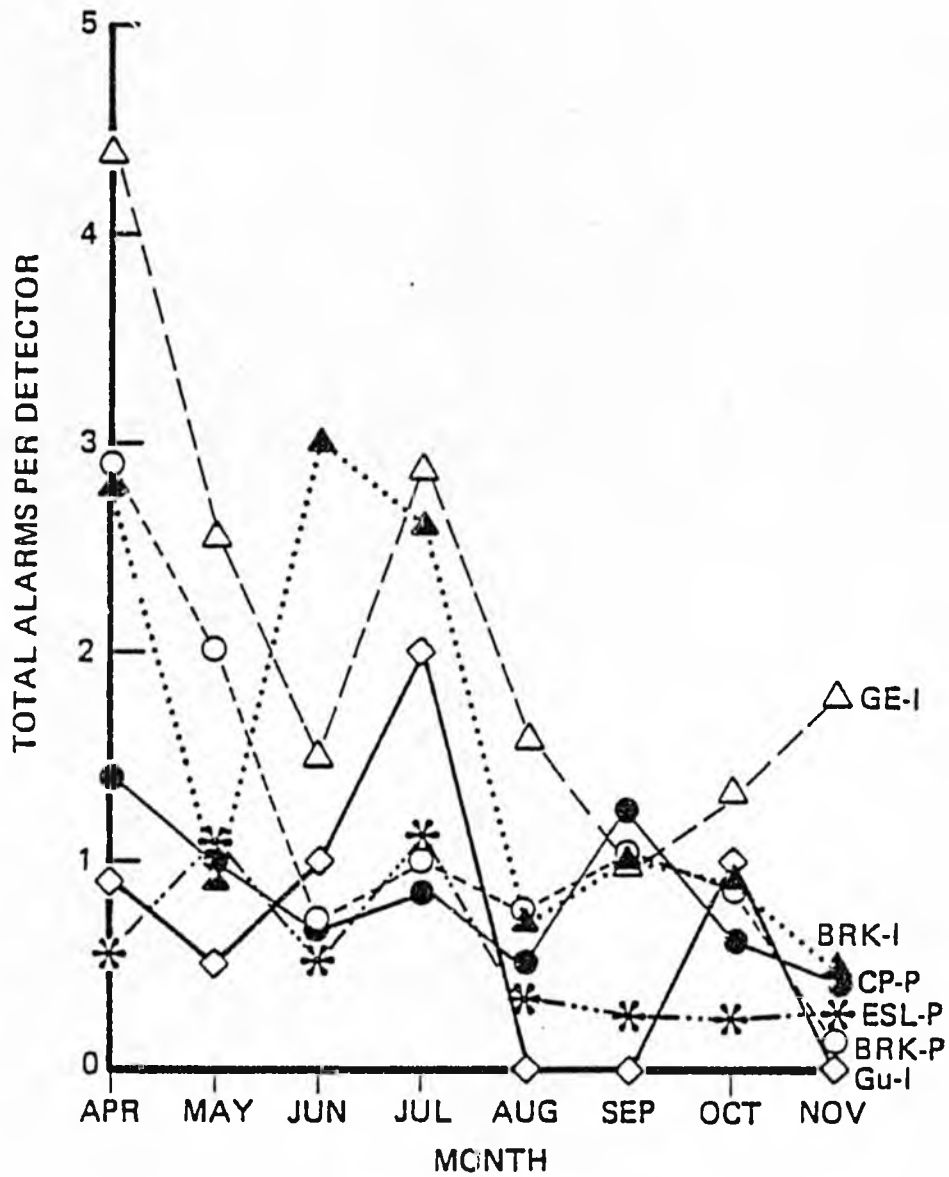

Figure 1. Total number of alarms per detector per month for the various brands over the test period.

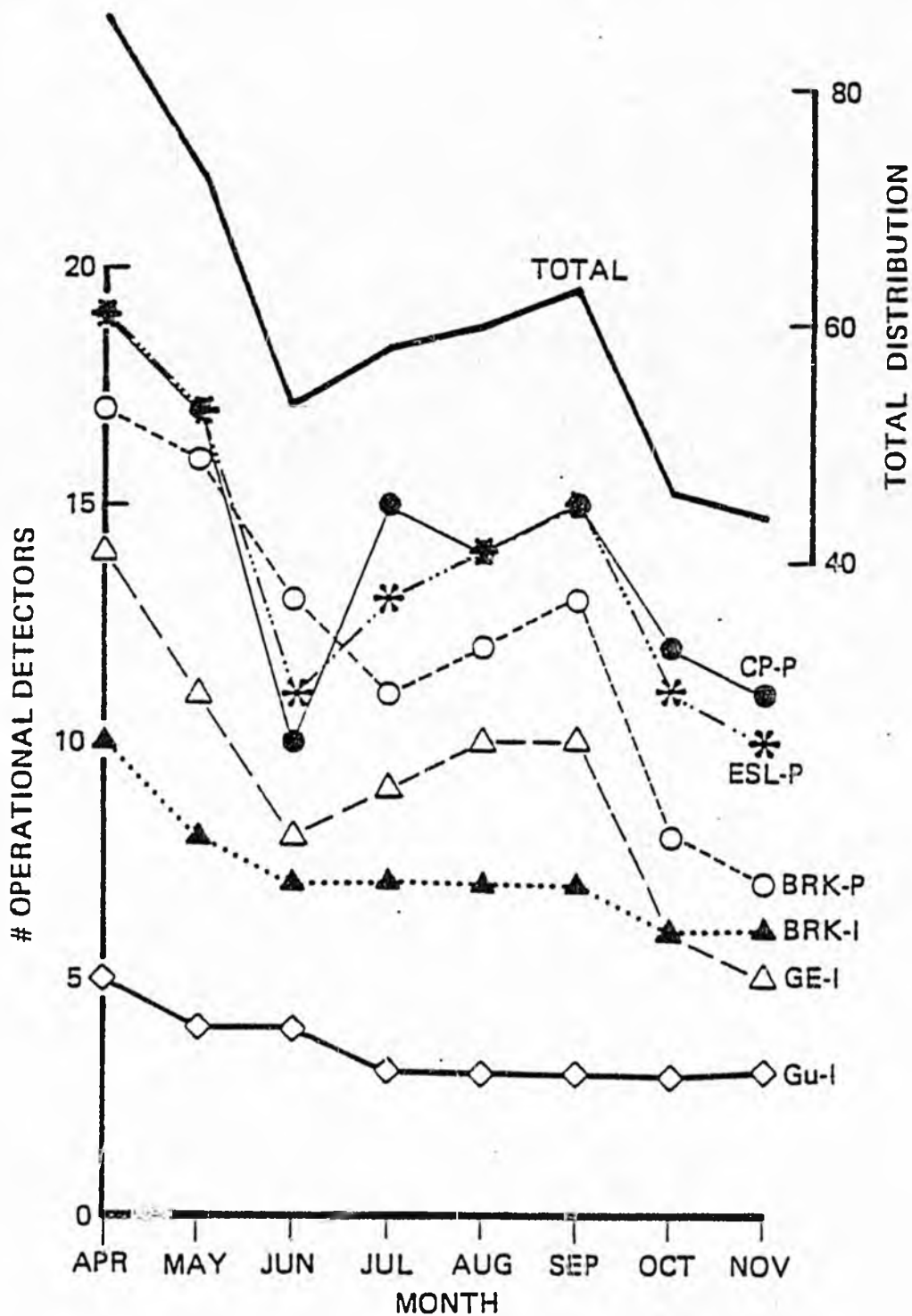

Figure 2a. Number of detectors of each brand group remaining operational each month during the test period. The total of all detectors in operation each month is indicated by the heavy solid line with numbers on the right.

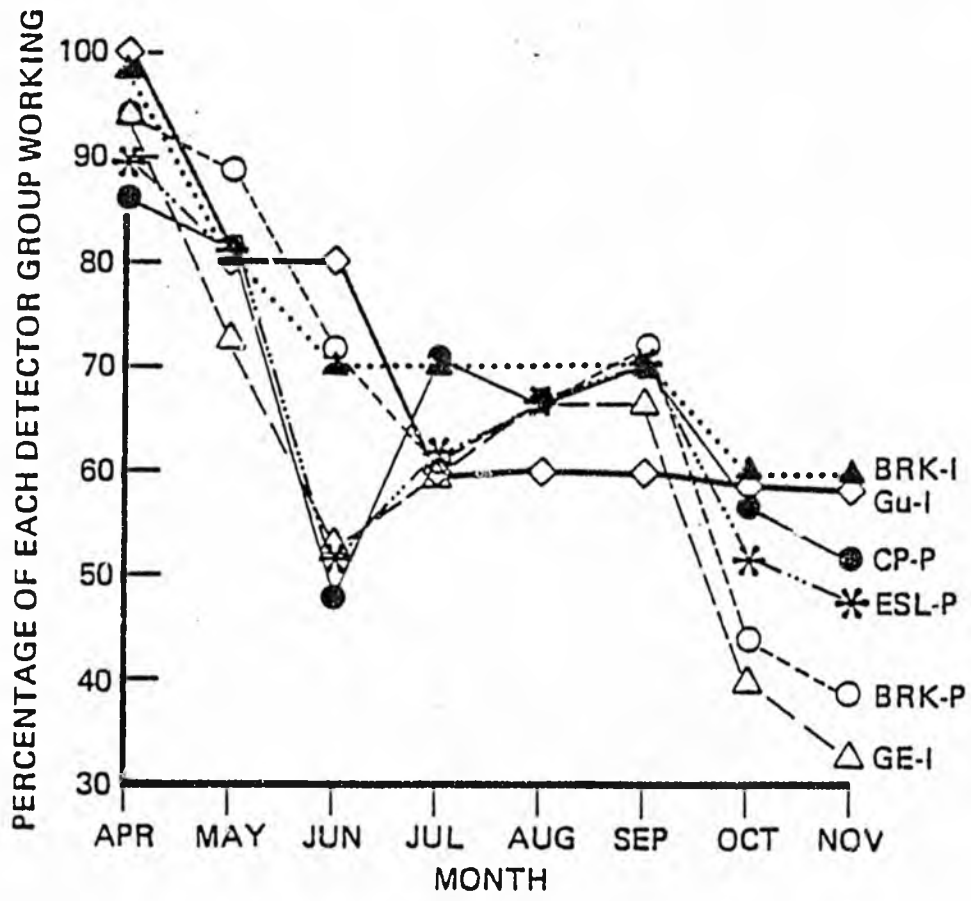

Figure 2b. Percentage of each detector brand group per month remaining in operation over the test period.

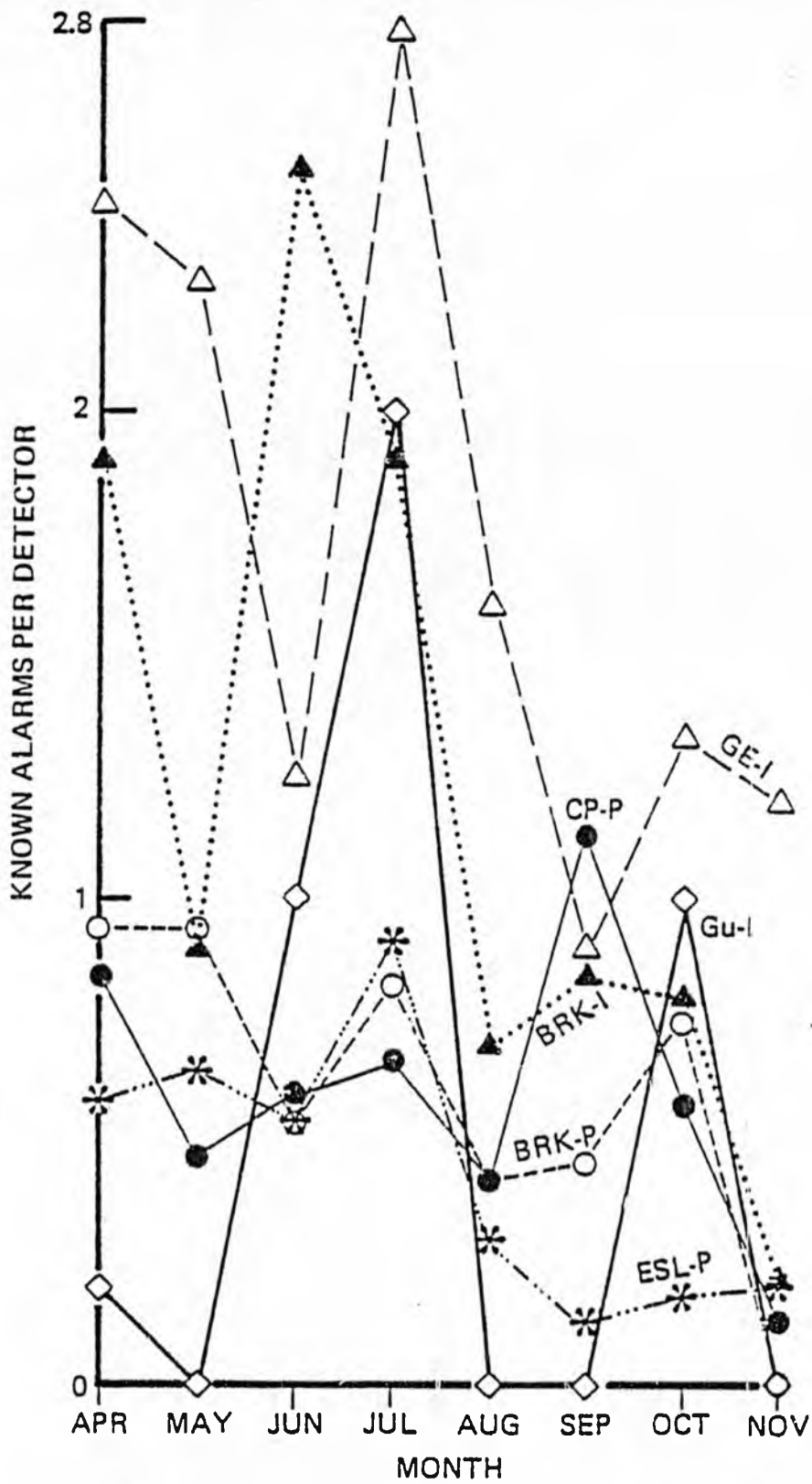

Figure 3a. Number of known alarms per detector per month for the various brands over the test period.

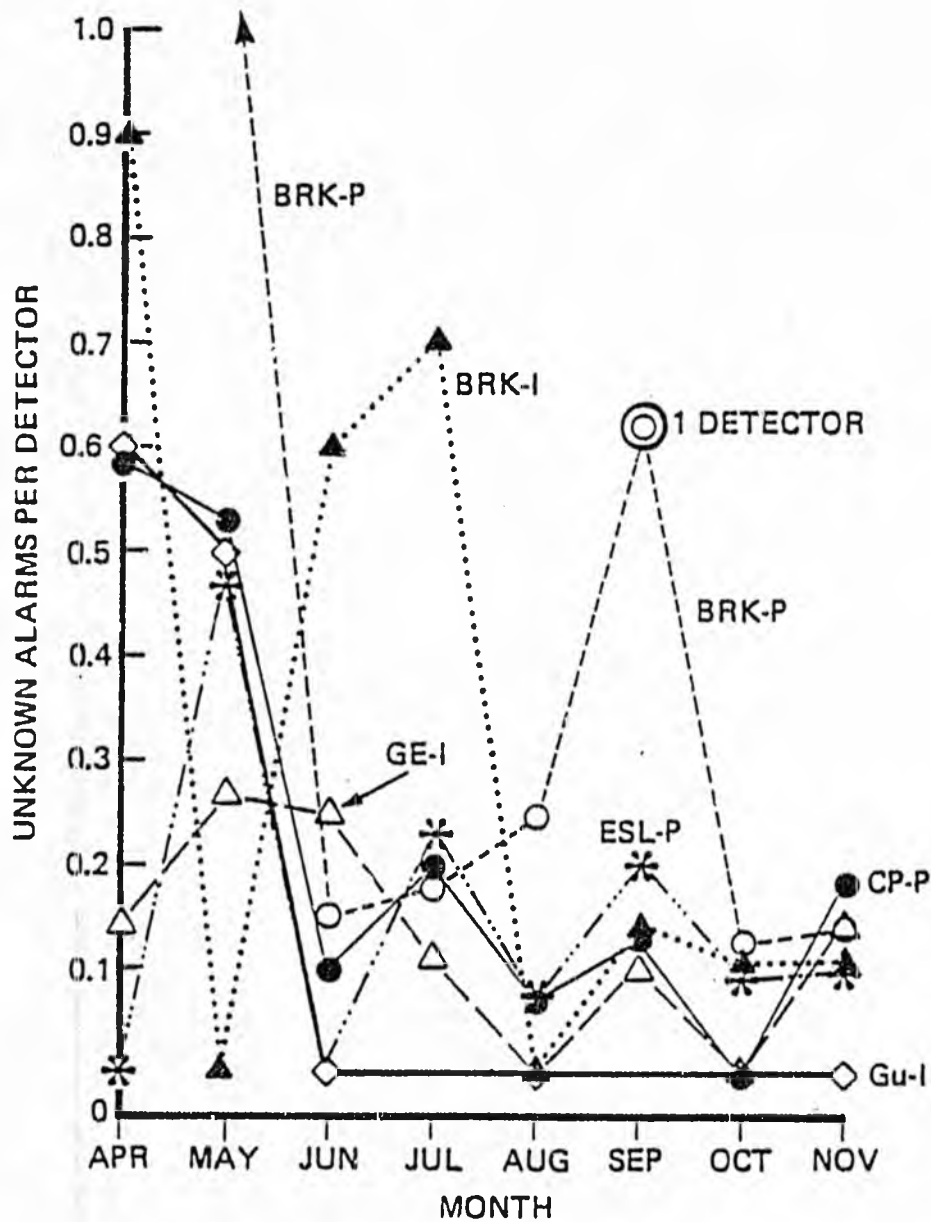

Figure 3b. Number of unknown alarms per detector per month for the various brands over the test period.

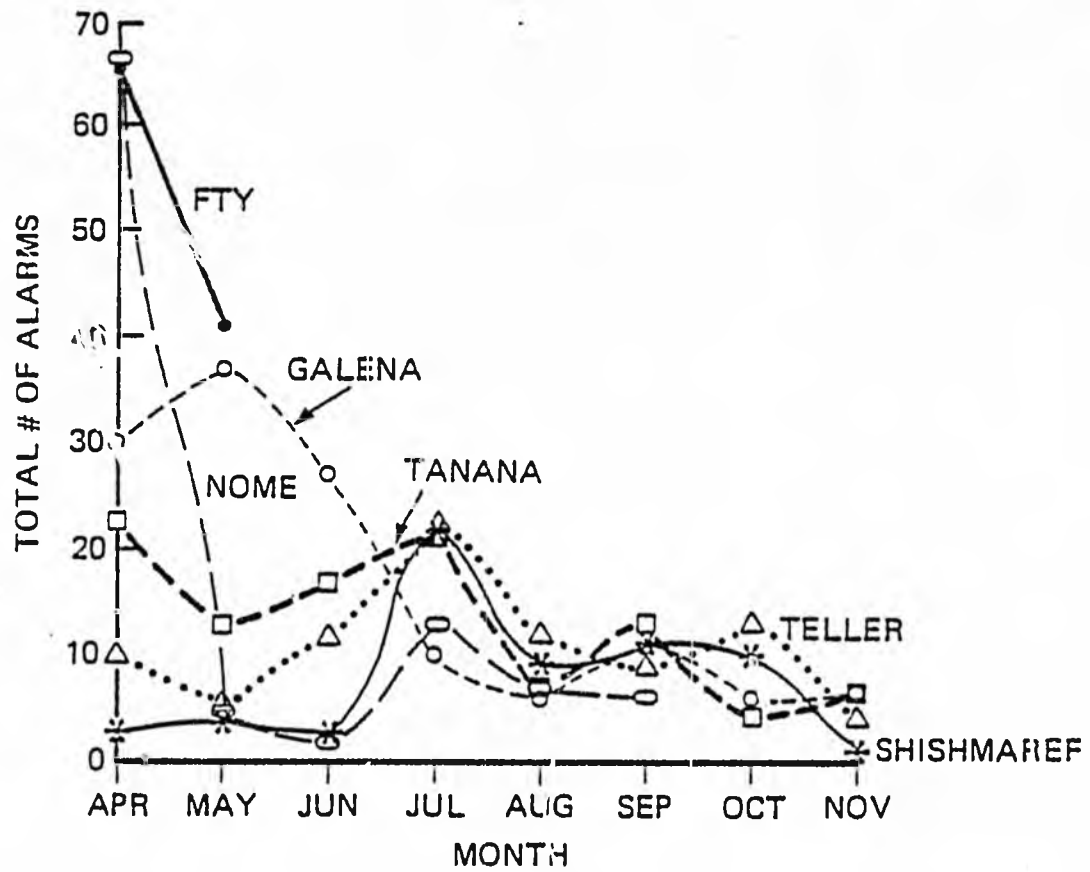

Figure 4. Total number of alarms per month at the different villages over the test period.

Figure 5. Types and Quantities of Alarms in Relation to Room Size

CAUSE	ROOM SIZE													TOTAL
	Small—<300 sq. ft.*						Large—>300 sq. ft.*							
	Ionization			Photoelectric			Ionization			Photoelectric				
	GE	G	BRK	BRK	ESL	CP	GE	G	BRK	BRK	ESL	CP		
Cooking	52	3	33	22	20	35	100	2	26	23	28	16	360	
Heating	oil	1	-	-	-	-	-	-	-	-	-	-	1	
	wood	8	1	3	4	-	7	3	-	-	3	1	31	
	both	-	-	2	2	-	5	-	-	1	-	-	11	
Other	1	-	-	3	1	12	2	-	5	5	3	3	38	
Unknown	5	2	13	42	5	19	8	-	5	20	6	9	134	

*The total number of houses was equally divided between these two measurements.

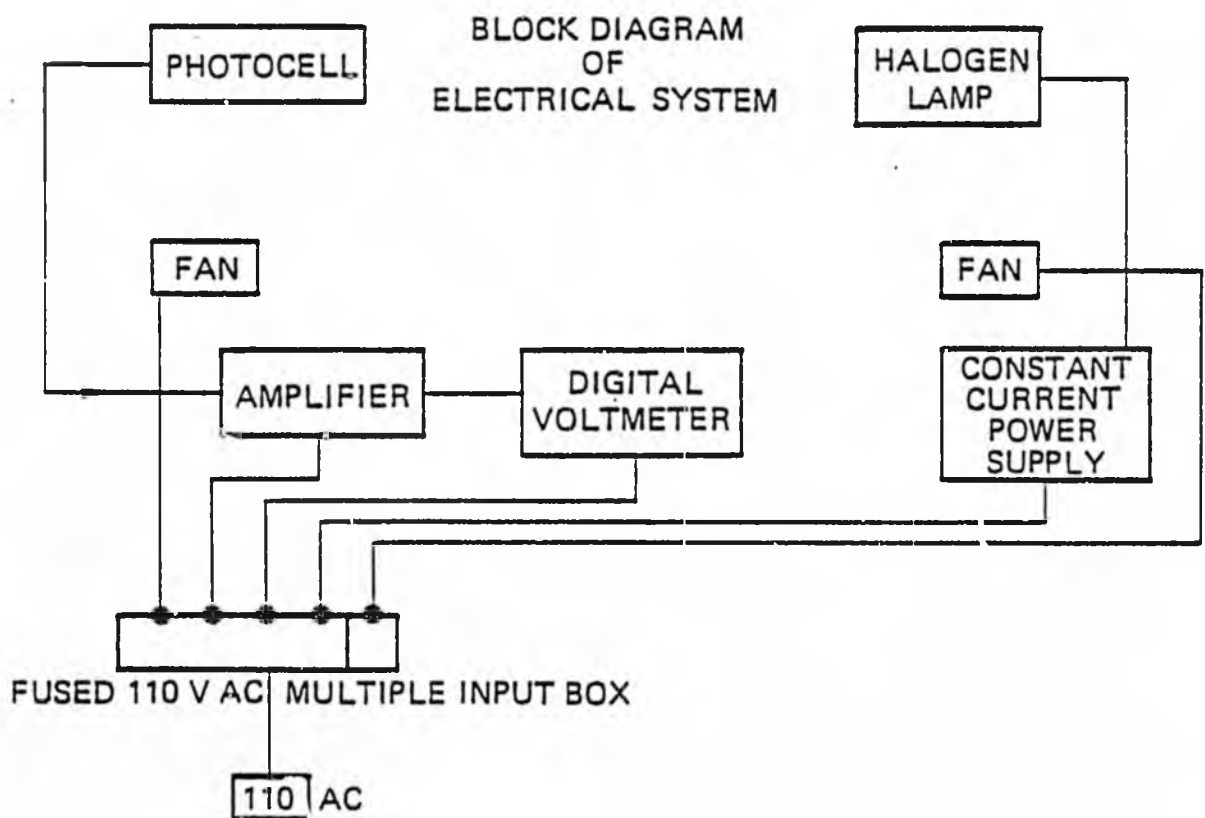
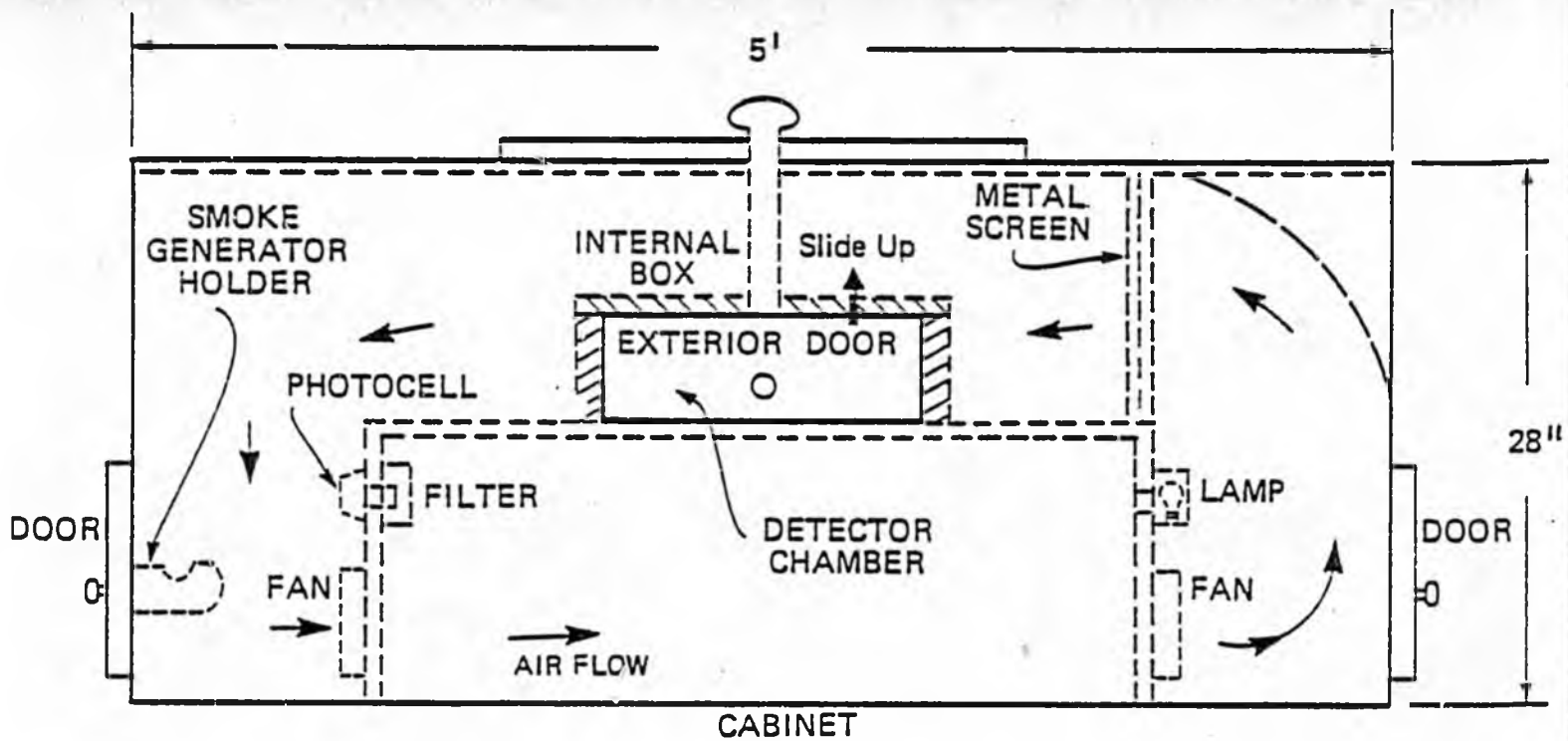

Figure 6. Basic diagram of the calibration smoke box and the electrical control circuit.

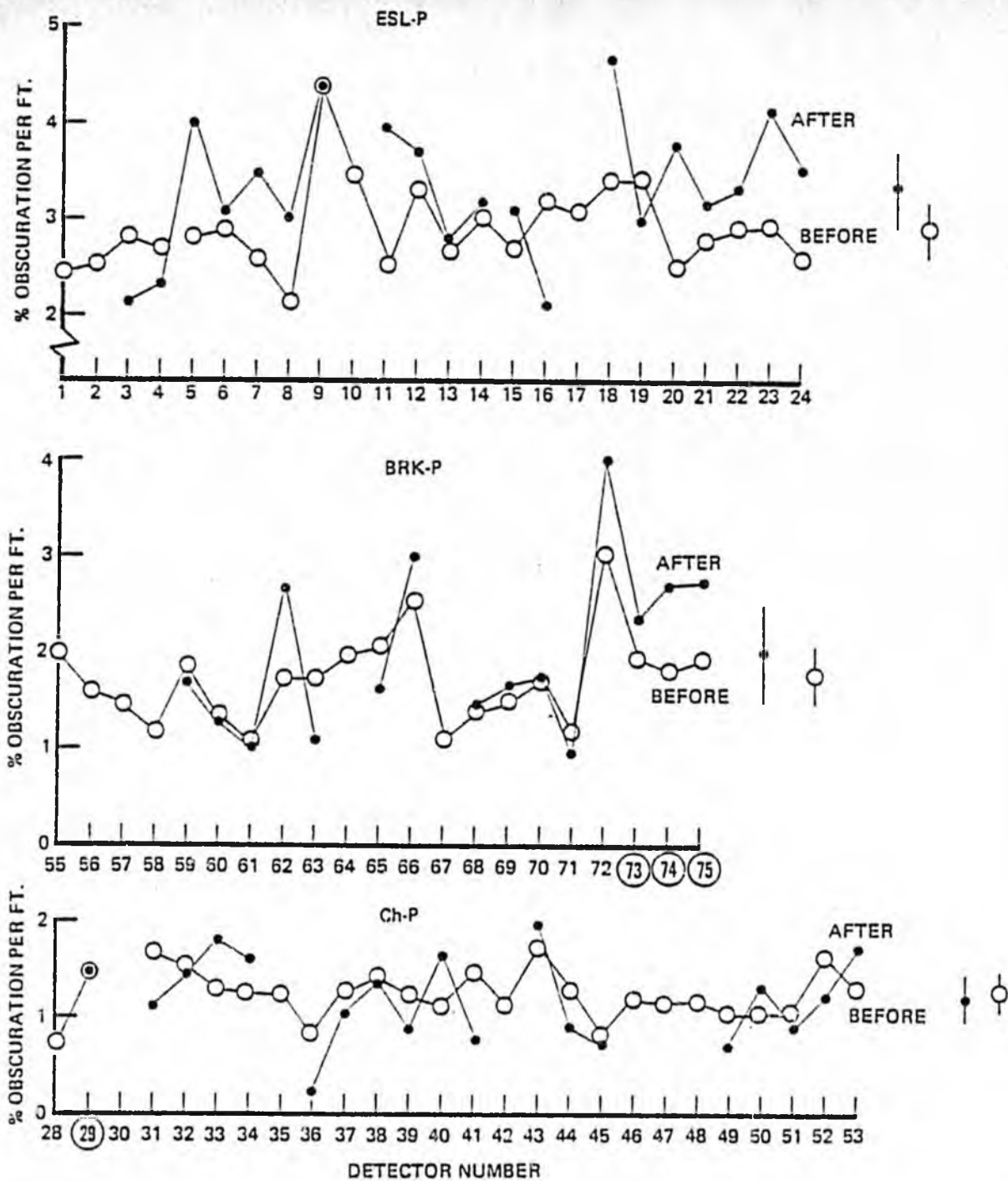

Figure 7a. Response of the photoelectric detectors to the level of smoke in the calibration smoke box before (O) installation in the villages and after (●) their return. The O and ● to the far right indicate the average response before and after for that group of detectors. The length of the vertical lines through these points represents the standard deviation of the group. The greater the percent obscuration per foot the greater the density of smoke in the box. The circled numbers are those detectors that remained in the lab as the control group.

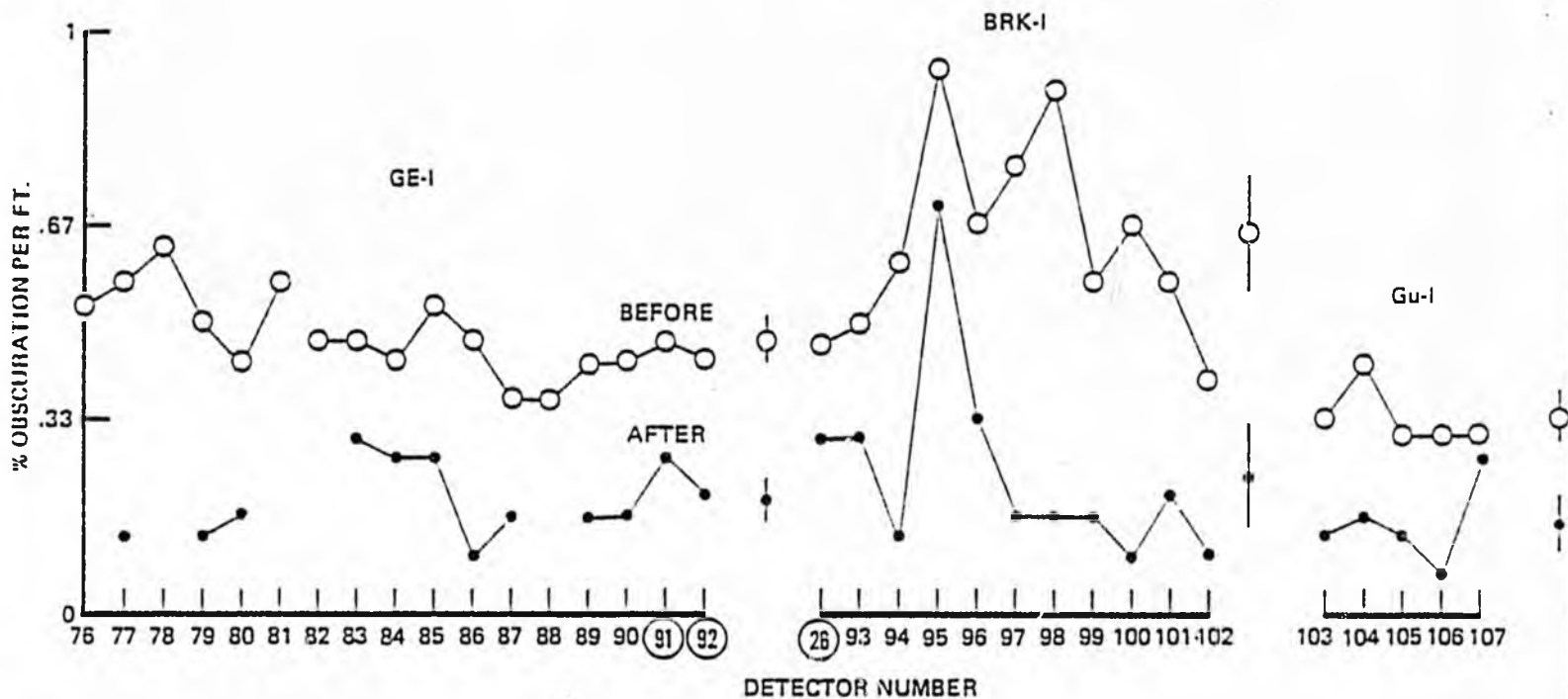

Figure 7b. Response of the ionization detectors to the level of smoke in the calibration smoke box before (○) installation in the villages and after (●) their return. The ○ and ● to the far right indicate the average response before and after for that group of detectors. The length of the vertical lines through these points represents the standard deviation of the group. The greater the percent obscuration per foot the greater the density of smoke in the box. The circled numbers are those detectors that remained in the lab as the control group.

**BACKGROUND INFORMATION FOR A RESEARCH PROGRAM ON
USE OF SMOKE DETECTORS IN RURAL ALASKA**

(Available on request: Alaska Council on Science and
Technology, Pouch CV, Juneau, AK 99811)

QUESTIONNAIRE

Village _____

Householder _____

Detector No. _____

1. Number of alarms:

No. single beeps _____ No. repeated beeps _____ No. continued buzzing _____

No. beeps not recorded _____

2. Unknown alarms:

Were they continuous or short beeps?

Possible cause(s).

3. Battery replacement:

No. changes _____

Due to repeated beeps every few seconds? If no, why changed?

4. Wire cut:

Yes or No _____ Why?

Any noticeable difference since cut?

5. Has the detector been acting differently since last month's report? How?

6. Attitude:

How do you feel about the usefulness of the detectors?

Do the false alarms reduce the effectiveness of them?

Would you want one in your house after the completion of the project?

Does the silencer make the detector better?

7. Comments:

Attitude:

Log keeping:

Dust:

FINAL QUESTIONNAIRE

Village _____

Householder _____

Detector No. _____

1. Have the detectors been acting differently since my (Nancy Smoyer) last visit, i.e., since the wires were cut/silencer chip replaced? How?
2. Have you had problems with:
 - Low batteries:
 - False alarms:
 - Single beeps:
3. Do the false alarms reduce the effectiveness of the detectors?
4. Does the silencer make the detector better/worse/no difference?
5. Have the detectors been acting differently since the weather turned cold? How?
6. How do you feel about the usefulness of the detectors? Why are they good/useful?
7. Would you be willing to recommend/suggest one for your neighbors?
8. How much would you pay for one? What is the most?
9. Are there any specific incidences when the detectors have warned of a potential fire?
10. Have you thought about/discussed with your family what you would do if the detector went off in the middle of the night? What is your plan?
11. Have you told the children what to do? What is that?
12. Comments about attitude and log keeping.
13. Which detector would you like returned to you? With/without silencer? Why?

VILLAGE COORDINATORS' INSTRUCTIONS

INTRODUCTION

The death rate due to residential fires in rural areas in Alaska is approximately five times higher than in urban areas, and the overall rate for Alaska is twice that of the rest of the nation. With these statistics in mind the Department of Public Safety is investigating the possibility of supplying smoke detectors to home owners in Alaskan villages and has determined that research on technical and social aspects of smoke detector use is necessary. The Alaska Council on Science and Technology was contracted by the Department of Public Safety to administer the research which will provide the information necessary to determine the effectiveness of smoke detectors in the unique conditions of Alaskan village homes.

Smoke detectors have been found to be a very effective means of saving lives by providing an early warning of fires. Two different kinds are made, ionization and photoelectric, which sense the smoke in different ways. Independent testing has found that photoelectric detectors respond quicker to smoldering fires (which are the cause of most residential fires), whereas ionization respond quicker to flaming fires.

In this project, primarily photoelectric detectors are being used because they have been found to be less subject to false alarms. The problem of false alarms is one of the major concerns of this testing because it is anticipated that the unique rural homes and lifestyles will cause more false alarms than would occur in other houses. This is due to the fact that: 1) houses are often smaller with one central living area, and 2) unusual amounts of smoke may be produced by the cooking and heating (and perhaps other) sources. The results of this testing will determine not only which kind of smoke detector is most effective in village conditions, but also where the detector should be placed within the home. The attachment of a device called a silencer, which enables the householder to turn off a false alarm for a short period of time, is also being tested on one detector in each house. Other modifications or unexpected results which will make the smoke detector more effective and also more acceptable to the villagers may be found.

In order to carry out this research a total of six villages in two regions (interior and coastal) have been chosen as test sites. Within each of those villages five homes will be selected to provide a cross-section of house constructions and life-styles. Three or four smoke detectors will then be placed in these homes, and the occupants will be asked to provide information about the smoke detectors, particularly the incidence of false alarms, for a period of six months.

ROLE OF VILLAGE COORDINATOR

To assist in all aspects of the testing in the villages, a resident of each village has been chosen to act as village coordinator. His or her role is vital to the success of the research. His advice and assistance will be crucial from the beginning of the program through the final evaluation at the end. Also, the village coordinator's understanding and positive attitude toward the usefulness of smoke detectors and this research program will have an influence on the homeowners' cooperation and enthusiasm in the project.

Specifically, the assistance of the village coordinator will be needed in the following areas:

1. Selection of houses. The proper selection of the houses is determined not only by the house construction, but equally importantly, by the attitudes of the occupants.
2. Placement of smoke detectors within the homes. Although the village coordinator will not be asked to actually select the location of the smoke detector in the homes

(this will be done by someone with experience in fire prevention from Fairbanks), his introduction to the householder and his presence during the installation process will be important in providing the link between the villagers and the project personnel. In some cases, the village coordinator might do the actual installation after the location of the smoke detector has been chosen.

3. Monthly visits. The village coordinator will be asked to visit each home once a month to collect the information log sheet, test the smoke detectors, answer questions, and generally evaluate the attitude of the people.
4. Final evaluation. The overall success of the program with respect to the activity of the smoke detectors and the attitude of the participants will be evaluated after six months.

To assist the village coordinators in recording his visits to the homes, two kinds of information logs will be provided.

1. The first will be filled out when the home is selected for the program.
2. The second kind will be filled out monthly to provide the findings of each visit.
3. In addition, the village coordinator will collect the logs which the householder himself has filled out during the month.

When these logs are completed, they will either be sent directly to the central project office in Fairbanks or picked up by a representative of the central office. The procedure for filling out the forms will be discussed later.

PAYMENT

Both the homeowners and the village coordinators will be paid for their cooperation in this program. The village coordinator will be paid a total of \$240 in six installments. \$40 will be paid at the beginning of the program, and a \$40 payment will be made each month after receipt of the logs by the central project office.

Each homeowner will be paid a total of \$150. \$50 will be paid when the smoke detectors are installed; payments of \$10 will be made after each monthly log is picked up; another payment of \$50 will be made at the end of six months. In addition, both the homeowners and the village coordinators will be given one of the smoke detectors to keep (after it has been given its final checkup).

LOGS

House Selection Characteristics

The form entitled House Selection Characteristics has been provided to record the choice of houses to be used in the testing. It is suggested that the village coordinator tentatively choose approximately 10 homes which he thinks meet the criteria for both house construction and homeowner attitude. At the time of the visit by the central project person, the five final houses can be determined together. The type of house being used in the testing is typically a log or frame one-room, low-ceiling building approximately 400-600 square feet with poor ventilation. Bedrooms are attached to the large living area, separated by a drape or a door. The cooking is done

on a gas, oil or wood range, and the heating systems are usually wood- or oil-burning stoves. Other types of houses can be used in the testing, but the emphasis should be on using houses which present conditions unique to rural Alaskan which would not be found elsewhere.

The items on the House Selection Characteristics form will be discussed in order to assist in the selection process.

1. Homeowner/address. Identification of house by owner and, if necessary, address.
2. Construction. In villages where there is a variety of construction, this mixture should be reflected in the choice of test houses. This could include log or frame houses or a combination of styles. However, some villages will have homes of only one basic type of construction, in which case a variety is neither possible nor desirable in choosing a representative sample.
3. Ceiling
 - a. Flat or sloped. Since smoke travels differently across flat or sloped ceilings, both types of houses should be tested. If it is sloped, an estimation of the gradient should be made as: slight, gradual, steep.

Beams are a special consideration for several reasons. Although we do not want to completely eliminate houses with beams, it is important to pay particular attention to homes which have them. If the beams extend more than about eight inches down from the ceiling, they could block the smoke from reaching the smoke detector. Also, if the beams are placed closer together than three feet, there will not be enough room to place the board with the smoke detectors. It might be possible to place the board either along the beam itself or across the beams if this seems to be the best location for a smoke detector under actual living conditions.
 - b. Height. In the case of a sloped ceiling, the height at the lowest and highest points should be measured if possible.
6. Heat source.
 - a. Oil. Because of the different forms of combustion used in gravity-fed or gun-fired oil furnaces, both kinds should be tested if possible.
 - b. Again, if several forms of heating are used in the village, a representative sample is desirable.
7. Cooking source. A representative sample of cooking methods in the village is preferred.
8. Lighting source. If the source of light produces smoke, this could affect the detectors.
9. Smoke detector placement. The distance from which the smoke detector is placed in relation to these objects will help us determine the cause of false alarms.

10. Family

- a. Number of occupants. The activities of different sized families and the amount of smoke produced may influence the occurrence of false alarms. Therefore, families of different sizes are required.
- b. Ages. For the same reasons, families of different ages are necessary.
- c. Scheduled absences. Absences of the family from the house are important to record for several reasons. If the family plans to be away for a large portion of the test period (more than six weeks), then the records may not be complete enough to be useful. On the other hand, shorter absences could be useful in the test since the life of the battery could be shortened if allowed to freeze, and false alarms might result. Therefore, it is necessary to know whether the house is heated during the absences. Both scheduled and unscheduled absences should be recorded during the monthly visits by the village coordinator.
- d. Attitude. The attitude of the family is difficult to record objectively and scientifically because it is more a matter of sensing their feelings, rather than asking direct questions. However, a brief statement about their attitude on this initial form will allow for some comparisons in follow-up visits. If the interest of the householder is too low at the beginning or drops significantly during the testing period, it is possible that he will be taken out if the village coordinator thinks that his attitude is influencing the record-keeping.

The attitude of *all* the family members is important to evaluate if possible because each person could play a role in producing and recording false alarms. A negative attitude of an individual member would be more harmful to the testing than a lack of interest if it took the form of deliberately altering the results in any way.

Some of the specific aspects to look for in choosing a family and determining their attitude toward the testing would be to find out how they feel about: 1) having a 2-to 3-foot board placed on their ceiling for six months and a log sheet on their wall; 2) having people (both known and unknown) come into their home to install the smoke detectors and then check up on them; 3) keeping a careful log of false alarms; 4) the possible occurrence of frequent false alarms.

- e. Education. The education level of the family members is important insofar as it relates to their understanding of this project. If there is little or no understanding of the purpose or procedures of the testing, the results cannot be considered to be reliable. As with evaluating their attitude, their education level would be determined not by direct questions, but rather by background knowledge of the village coordinator or general questions.
11. The main activity of the family in the room where the smoke detector is located will help determine the cause of false alarms as well as the probable frequency. An estimation of how much smoking is done in this room would be useful, too.
 12. Floor plan. As accurate a floor plan as possible will help to determine the cause of false alarms as well as give a visual picture of the house and relative placement of the smoke detector.

Monthly Visit

The monthly visits which will be done by the village coordinator will have several purposes: 1) to collect the householder's log and leave another, 2) to test the smoke detector, 3) to evaluate the attitude of the family, 4) to provide on-going explanations and encouragement on the project. A log sheet will be used by the village coordinator to record his findings and will be sent monthly to the central project office.

This Monthly Visit log will provide the following information:

1. The house, date visited, and smoke detector numbers.
2. Testing results. The village coordinator will actually test the operation of each detector and record whether it is OK or Not OK. If some unusual action is necessary, it should be recorded and described with as much detail as possible as to the nature of the problem, cause, action taken, recommendations. If a detector alarm does not sound during testing, the battery should be replaced, and then the detector left in place whether it works or not.
3. Absences. It will be necessary to inquire about absences during the month in order to determine whether the battery of the smoke detector may have been frozen, and if so, for how long.
4. Attitude of family. General observations and particularly changes in the attitude of the family should be noted here. Other observations which can be indicated might include such things as: whether one family member is particularly enthusiastic or the opposite, whether all the members seem to be cooperating or only one or two; general observations and recommendations.

It is anticipated that some smoke detectors will be removed by the researchers for one reason or another. This could be due to factors such as the family moving or requesting the removal because of too many false alarms. However, sometimes the village coordinator himself will have to make the recommendation to remove the smoke detectors with the approval of the central project office. If the annoyance of false alarms becomes too great or the attitude of the family deteriorates for any reason to the point that the test results will be unfairly influenced, the smoke detectors should be removed. If the family does not seem to be cooperating within the first two months of the project, the smoke detectors will be removed and placed in another house. In the case of unwanted false alarms, it may be possible to remove the battery from the most annoying detector and continue the experiment with the others. In any case, the judgment of the village coordinator will be very important in detecting the changing attitudes as well as making recommendations.

It is also possible that the village coordinator will be unable to pick up the Householder's Log for one reason or another. If the family has lost their log or forgotten to fill it out, the village coordinator can question them about the activity of the smoke detectors during the past month to try to get as much information as possible. However, if good records cannot be obtained from the householder for two months in a row, the family may be removed from the project. It is possible that the family will be away at the time of the monthly visit in which case the village coordinator should fill out his regular report within one week indicating that they were not there. He will then get the Householder's Log as soon as possible and carry out his regular monthly test and interview at that time. No doubt other unforeseen situations will arise which will have to be dealt with by the village coordinator together with the central project office.

Householder's Log

The householder will be given a packet which will contain his logs with brief instructions and background information about this project and smoke detectors. The family should be able to fill out this form with no assistance from the village coordinator. This log is used primarily to record the frequency and cause of false alarms, as well as the action taken to stop the alarm. In addition, certain items have been included to help evaluate the interest of the family in the smoke detectors themselves. These items are: 1) the name of the person recording the information, and 2) how often the detector is tested. The family is also encouraged to write their comments about the detectors and the project on the log.

CONCLUSION

In conclusion, we would like to emphasize again the key role of the village coordinators in the overall success of this test project. The village coordinators' interest, enthusiasm and motivation are important not only in the work which they themselves do, but also in the influence which they will have on the participation of the families. The thoroughness and carefulness with which the coordinators complete the forms may also be reflected in the care taken by the families.

It is hoped that the village coordinators view the long-range goal of providing smoke detectors for all the homes in the villages as a valuable life-saving means, and in addition, that they understand the immediate benefits of making the people more aware of the danger of fire and its detection and prevention.

HOUSEHOLDER INSTRUCTIONS

INTRODUCTION

Loss of life and property by fires in homes is much higher in Alaskan villages than in the rest of the State. For that reason the Department of Public Safety will be offering smoke detectors at a low cost to village residents. Smoke detectors have been found to be essential in warning people of fires in their homes giving them time to escape. There are two kinds and many brands of smoke detectors made. Ionization detectors have been used in most homes in the past. However, a newer kind called photoelectric may be better suited for village conditions.

The houses and lifestyles of village residents are quite different than the rest of the United States. Some of these differences, such as small one-room houses and wood-burning stoves, can cause problems for smoke detectors. The detectors are made to "smell" or "see" smoke and then sound an alarm to warn the inhabitants. However, the smoke detectors do not know the difference between "friendly" smoke, such as from a wood-burning stove, and "unfriendly" smoke, such as from a smoldering mattress. Because there is likely to be more "friendly" smoke in village homes than others, false alarms could be a great problem. It is to test the frequency and cause of these false alarms that this research is being done.

You are one of several families in 6 villages in Alaska we have asked to put 3 smoke detectors in their homes. The smoke detectors will be left in your home for 6 months during which time you will record on a chart what the detectors do. A person in your village, the village coordinator, will collect these charts from you once a month to send to Fairbanks. You will be paid \$50 at the beginning of the project and \$10 more at the end of every month. At the end of the entire project you will be paid \$50 more to total \$150 in all.

HOUSEHOLDER'S LOG

This chart (or log) will be used for you to record what happens each time an alarm goes off. All of these answers will help determine which smoke detector is best to use in the villages. Therefore, *it is very important to record each alarm carefully and completely.* The chart is to be filled out each time an alarm goes off in the following way

1. Detector Number/Color. Each time an alarm goes off, write the number or color of the detector which is sounding.
2. Date. Write the day's date.
3. Time. Write the approximate time the alarm goes off.
4. Name. Write the name of the person recording the information.
5. FALSE ALARM CAUSE. False alarms can be caused by many things, so it may not always be possible for you to know exactly. Some of the possible causes could be smoke and fumes from the following sources:

Cooking—fumes from cooking can cause false alarms whether you can see smoke or not.

Heating—Wood-burning stoves: when the fire is started or the door is opened to add wood smoke may escape.

Oil-burning stoves: malfunction of controls may cause smoke.

Lighting—the smoke from oil- or kerosene-burning lamps.

Smoking—smoke from many cigarettes.

Unknown—If you don't know what caused the alarm, put an X here.

Other—If you know the cause and it is not one of the boxes on the chart, write in what you think caused the alarm.

6. ACTION TO STOP ALARM. Several actions can be taken to stop the alarm.

Nothing—Put an X here if the alarm stops without your doing anything.

Pushed Button—Put an X here if you push the silencer button. If the alarm comes on again, write down another false alarm.

Fanned Air—Sometimes fanning the smoke away from the detector will stop it.

Removed & Replaced Battery—The battery can be removed to stop the alarm, but it should be replaced as soon as possible. Do not remove the battery permanently without telling your village coordinator.

7. Tested. You may want to test your smoke detector by pushing the test button on the detector itself. This will tell you whether it is working or not. Write down when you do it.
8. Comments. If you have any comments about the smoke detectors or the program in general, write them down here.

PROBLEMS

Several problems could occur over the 6-month period. False alarms could become very bothersome. If you find that one or more of the detectors is particularly annoying, tell your village coordinator. He or she will then take some action. It is *very important* to record anything done by or to the smoke detectors so we can know how the detectors are acting. For instance, one of them may stop working. This could be due to several factors and your village coordinator will know what to do. A detector could start sounding at regular intervals for no obvious reason. This could be because the battery is low. Tell your village coordinator and he or she will replace the battery. Another problem could be misplacing the chart. If that happens, start another one but try to record all the false alarms you can remember from the lost chart. The village coordinator has extra charts and will bring you new ones every month. If you plan to be away from your home for more than 2 weeks, tell your village coordinator. If you have any questions or problems, talk to your village coordinator or call us collect at 479-7010.

As you can see, you are the most important person in this project. You are the one who hears the alarm. You are the one who writes down what happens every time. And you are also the one who may be bothered by false alarms. But with your cooperation, a smoke detector will be found which may save your life as well as your neighbors.

Interviewer

MONTHLY VISIT

Homeowner:

Date:

1. Detector number/color:
Test results: (OK, Not OK)
Action taken:

2. Detector number/color:
Test results: (OK, Not OK)
Action taken:

3. Detector number/color:
Test results: (OK, Not OK)
Action taken:

Absences:

Dates

Detectors Frozen (Yes, No, Don't Know)

Attitude of family:

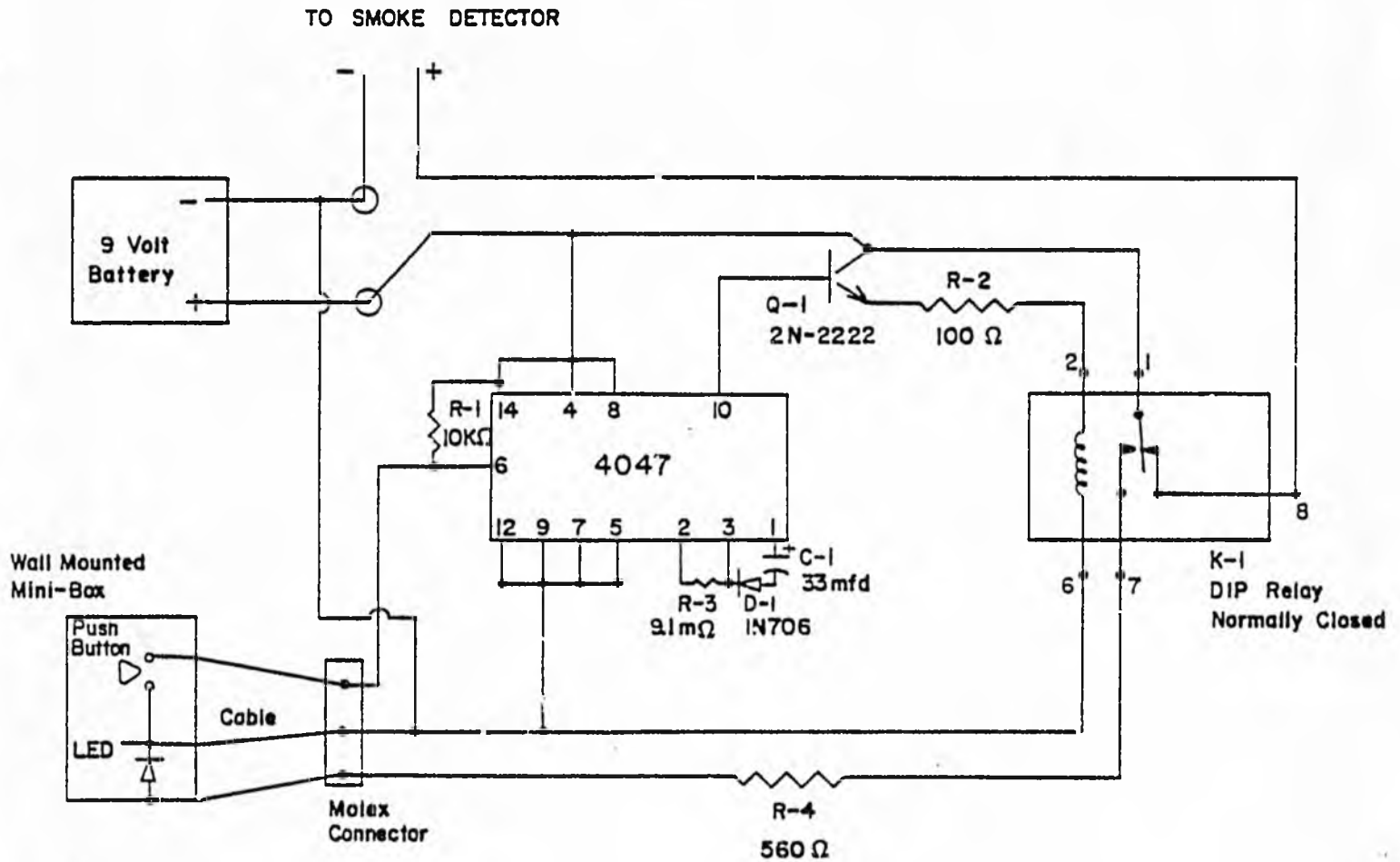

Silencer circuit installed in the smoke detectors prior to their installation in the villages.



F

THE ALASKA COUNCIL ON SCIENCE AND TECHNOLOGY

SYNOPSIS OF GRANTS

For the Alaska Council on Science and Technology

Northern Technology Grants Program

1979 through 1982

April, 1982

Northern Technology Grants Program

The Northern Technology Grants Program began when the Alaska state government appropriated funds in July, 1979. These funds were to be awarded by ACST in grants up to \$5000 to Alaskans with innovative ideas in northern technology.

The initial program was so successful that in 1980, 1981 and 1982 additional grant funds were awarded to ACST to conduct three more Northern Technology programs.

The program has awarded grants to projects that are low-cost alternatives for Alaskans in such areas as building design, food production, recycling, transportation, energy generation and waste disposal. The immediate benefit of the grant is to the person with the idea but the long-range benefit will be to all Alaskans. Grant recipients are required to provide a progress report to the ACST and in many cases, recipients conduct demonstration workshops on project results for community members or other interested Alaskans. Also, the Alaska Council on Science and Technology publishes "Technical Briefs" on the successful projects. These short "how to" reports are intended to show others in the state how grant recipients completed their projects while also describing pertinent results.

This is a list of all 113 Northern Technology awardees and synopses of the projects. For more information concerning the program contact: Alaska Council on Science and Technology; Pouch CV; Juneau, Alaska 99811 or telephone (907) 465-3510.



TABLE OF CONTENTS

1979 GRANTS.....	1
Regenerative Freezer (0011).....	1
Juice Bottling Plant (0107).....	1
Hydraulic-powered Auto (0146).....	1
Bee-overwintering Building (0083).....	2
Waste-heat-claiming Greenhouse (0029).....	2
Solar Hot Water Heater (0089).....	2
Insulated Shutters (0144).....	2
Tidal/Current Hydraulic Suction Dredge.....	3
Solar Greenhouse (0139).....	3
Oil Fired Clothes Dryer (0145).....	3
Methyl-fuel Plant (0165).....	4
Hydroelectric Generator (0155).....	4
Wood Furnace (0136).....	4
Electric Car (0098).....	4
Solar Greenhouse (0074).....	5
Ambulance Splint (0027).....	5
Hydroelectric Generator (0129).....	5
Solar Heater (0065).....	5
Waste-Oil Heater (0106).....	6
Experimental Greenhouses (0180).....	6
1980 GRANTS.....	7
Induction Generator (0506-80D).....	7
Solar Space Heater (0226-80).....	7
Furnace Conversion.....	7
Treatment Unit (0312-80).....	7
Battery or Fuel Cell Made From Scrap Metal (0508-80D).....	7
Window Insulation (0036-80).....	8
Dog, Water or Wind Powered Washing Machine (0358-80 & 0359-80)....	8
Greenhouse (0515-80D).....	8
Wind Generator (0098-80).....	8
Waterproofing for Earth Shelter House (0165-80).....	9
Greenhouse (0055-80).....	9
Trailer Steering Device (0081-80).....	9
Recycling Aluminum Scrap (0085-80).....	9
Generator (0332-80).....	9
Solar Heat House (0072-80).....	10
Boiler System (0155-80).....	10
Solar Wood Drying Kiln (0116-80).....	10
Wind Generator (0540-80D).....	10
Digester (0045-80).....	11
Improved Willow Rake (0374-80).....	11
Fruit and Nut Tree Cultivation (0298-80).....	11
Permafrost Excavation (0232-80).....	11
Hybrid Electric Car (0281-80).....	11
Plant Hydro Feed System (0290-80).....	12
Passive Solar Home Plans (0159-80).....	12
Shutters for Greenhouse (0327-80).....	12
Subterranean Outbuildings (0130-80).....	12
Solar Thawing of Permafrost (0044-80).....	12

1980 GRANTS (Continued)

Effective U-Value Measurements (0139-80).....13
 Arctic Home Construction (0505-80D).....13
 Solar Greenhouse (0328-80).....13
 Home Energy System (0118-80).....13
 Methane Generator (0362-80).....13
 Automated Thermal Shutters (0309-80).....14
 Technique for Shallow Subsurface Exploration (0020-80).....14
 Generating System (0538-80D).....14
 Data Recording Instrument (0205-80).....14
 Solar Energy Heating System (0064-80).....14
 Solar Wood Drying Kiln (0248-80).....15
 Water Heating (0177-80).....15
 Fish Drying Process (0145-80).....15
 Steam Plant for Small Boat (0262-80).....15
 1 Watt Translator (0166-80).....16
 Home Energy Conservation System (0234-80).....16

1981 GRANTS.....17
 Development of Clam Harvesting Technique (063-81).....17
 Development of a Cam Operated Arctic Door Design (061-81).....17
 To Grow Fruit Trees in the Yukon-Tanana Uplands (115-81).....17
 To Convert a VW Bug to a Hybrid-Electric Vehicle (110-81).....17
 To Use Spill-Over Energy From a Hydraulic Windmill (117-81).....18
 Equipment for Sensitivity and Cold Temperature Testing of
 Smoke Detectors (131-81).....18
 Heat Pump for Foundation Stabilization (118-81).....18
 To Install a High-Pressure Jet Modification to a Clam
 Harvester (066-81).....18
 Device to Test Soil Strength (061-81).....19
 To Develop a Submersible Investigating Drone (069-81).....19
 To Study the Feasibility of Migratory Bee/Honey Operation
 Sympathetic to Delta Barley Project (070-81).....19
 Wind Powered Heat Pump and Lighting System (003-81).....19
 Mariculture of Subtidal Red Seaweeds (005-81).....20
 To Construct a Dual-Layer Greenhouse on Alaskan
 Peninsula (020-81).....20
 To Refine Indoor Hydroponic System (022-81).....20
 To Develop a Method of Producing Ethanol Alcohol (026-81).....20
 High Temperature Surface Combustion Techniques (028-81).....20
 To Construct a Chicken House and Solar Pit Greenhouse (031-81).....21
 Composting Techniques Experimentation (033-81).....21
 To Reuse Waste Heat from Laundromat (038-81).....21
 To Construct a Solar Semi-Subterranean Barn/Root Cellar (052-81).....21
 Construction of Electric Hybrid Car (057-81).....22
 Improved Hydraulic Ram for Use on Streams in Interior
 Alaska (056-81).....22
 Wood Fueled Electricity Generator (059-81).....22
 To Develop a Micro High Head Hydroelectric Site for Reduction
 of Fossil Fuels (077-81).....22
 To Reuse Waste Computer Paper.....22
 Emergency Solar Power for Small Boats (004-81).....23
 To Recycle Aluminum Cans (013-81).....23
 River-Powered Electrical Generator (021-81).....23
 Installation of Self-Timer Silencers on Smoke Detectors (130-81).....23
 To Dive to Record Abundance and Distribution of Seaweeds(006-81).....24

1982 GRANTS.....	25
Wood Utilization Survey in the Fairbanks North Star Borough (N-82-01).....	25
Development of an Automatic and Manual Fuel-Saving Floor Register (N-82-02).....	25
Frozen Food Processing Plant (N-82-14).....	25
Documentation of Off-Peak Electric Heating Systems and Usage (N-82-23).....	26
Design, Development and Test Manual, Semi-Automatic and Automatic Controls for Thermal Shutters (N-82-26).....	26
Design and Construct Waste Oil Furnace (N-82-44).....	26
To Develop a Microprocessor Controller to Optimize Hot Water Heater Usage (N-82-49).....	27
Bandsaw Power Alternative for Bush Areas (N-82-51).....	27
Cross-Transmission of Coccidiosis between Wild and Domestic Alaskan Sheep (N-82-72).....	27
Studio-Sized, Hydraulically Powered Impact Mill (N-82-77).....	28
Soil Heated Food Production With Seep Irrigation (N-82-87).....	28
Winter Storage for Root Crops (N-82-103).....	28
Development of a Low-Cost, Lightweight, Solar Snow Melter for Expeditionary and Remote Site Use (N-82-107).....	28
To Develop a Hydro-Power Generation System (N-82-109).....	29
Monitoring of Interior Window Insulations (N-82-80).....	29
Instrumentation for a Small Hydro-Power Project (N-82-108).....	29
Fish Meal and Oil Producing Raft (N-82-119).....	29
Hydrogen Gas Generation by and for Boats (N-82-38).....	30

ALPHABETICAL CROSS REFERENCE
1979-1982 GRANTS

Abegg, Frank III (N-82-44).....	26
Alakanuk City Council (0506-80D).....	7
Alaska Altern. Energy Resources Ct (0226-80).....	7
Alaska Federation for Community Self-Reliance (0327-80)....	12
Albert, Phillip (0130-80).....	12
Bailey, Don (0008-80).....	7
Bair, Norman (0312-80).....	7
Balch, Joseph (0044-80).....	12
Barger, James (0029).....	2
Beaudoin, Douglas (068-81).....	19
Benevento, John (131-81).....	18
Berson, Thomas R (0508-80D).....	7
Bingham, Bert (0146).....	1
Black, Joseph Charles (N-82-38).....	30
Brown, Pete (021-81).....	23
Butera, Louis (N-82-108).....	29
Calvin, Natasha (005-81).....	20
Carlson, Paul (070-81).....	19
Carney, Steve (0027).....	5
Carlson, Axel R (0139-80).....	13
Cassell, Kenneth (077-81).....	22
Cloyd, Bobby (0505-80D).....	13
Corbridge, Clark (117-81).....	18
Coutts, H. J. (057-81).....	22
Crawford, Michael (0328-80).....	13
Cunningham, Jim (0036-80).....	8
Davies, John (N-82-26).....	26
DeBoard, Carl (063-81).....	17
Delbridge, Craig (026-81).....	20
Detzel, Jack Jr. (052-81).....	21
Dillon, John (0118-80).....	13
Donally, Jim (0180).....	6
Doner, Alfred (0155-80).....	10
Ellis, Robert (006-81).....	24
Ford, Richard (0155).....	4
Forster, Bruce (0116-80).....	10
Friedman, Bonnie (115-81).....	17
Gerow, Eugene (033-81).....	21
Grimm, Douglas (0165).....	4
Grove, David (0098).....	4
Guthrie, R. Dale (118-81).....	18
Gurtler, Stanford (N-82-103).....	28
Hall, Bill (0358-80 & 0359-80).....	8
Hart, K. Quinn (0515-80D).....	8
Hicks, Steve (0098-80).....	8
Hightower, William (0540-80D).....	10
Hoke, O. Alexander (0162).....	3

Hornberger, Charles & Sara (020-81)	20
Isaacs, Marnie & John (0165-80)	9
Jablonowski, Richard (N-82-49)	27
Johansen, Chris (0065)	5
Johnson, Edward (0045-80)	11
Jones, Cecil R. (0374-80)	11
Kirchhoff, Matthew (N-82-51)	27
Klein, Ronald (0262-80)	15
Knoebel, Ed (0055-80)	9
Lamb, Chris (0362-80)	13
Laroe, Steve (N-82-01)	25
Leis, Karen (0298-80)	11
Loeffler, Michael (N-82-109)	29
Matheson, Alex (0081-80)	9
McDonald, William (N-82-80)	29
McDougall, Kevin (0011)	1
McGrath, Ed (0309-80)	14
McHattie, Robert (0020-80)	14
Miller, Richard (059-81)	22
Moen, Daniel (013-81)	23
Molvik, David (0166-80)	16
Moor, Jay (0234-80)	16
Neville, Ted (0129)	5
Newell, W. Charles (110-81)	17
Nielson, Carol (N-82-72)	27
North, Nancy (079-81)	22
Olanna, George (004-81)	23
Olson, Erick (003-81)	19
Orth, Joy (031-81)	21
Pelz, Carl (0538-80D)	14
Pendergrast, Donald (0106)	6
Phillips, John (0085-80)	9
Posciri, Charles (0232-80)	11
Potter, Mike (0145)	3
Quirk, John (N-82-87)	28
Quiroz, Ricardo (0281-80)	11
Radio Communications Inc. (0332-80)	9
Raymond, James (0205-80)	14
Reinhart, Robert (0072-80)	10
Riche, N. Meade (056-81)	22
Rowcroft, Michael (0107)	1
Ruef, Donald (0136)	4
Sanders, Phillip W (061-81)	17
Scott, Julie (0089)	2
Seifert, Richard (0064-80)	14
Shadura, Elizaveta (0290-80)	12
Shaw, Albert (N-82-23)	26
Simmons, Charles (0248-80)	15
Simmons, Horace (028-81)	20
Smiley, Steven B (159-80)	12
Smith, Randy and Larry (069-81)	19
Smoyer, Nancy (130-81)	23

Stam, John (N-82-119).....	29
Stannard, David (N-82-77).....	28
Stark, Max (N-82-14).....	25
Stoops, David (0083).....	2
Stoppenbrink, Norm (0180).....	6
Stultz, Ed (066-81).....	18
Sturm, Matthew (N-82-107).....	28
Tack, Cyndie & Stephen (0139).....	3
Viereck, Leslie A (0177-80).....	15
Wagner, Dane (N-82-01).....	25
Walton, Robert (0144).....	2
Weld, Jeremy & Linda (0074).....	5
Wik, Ole (0145-80).....	15
Wilcox, James (038-81).....	21
Winograd, Ira (022-81).....	20

REGENERATIVE FREEZER (0011)

Kevin McDougall
 P. O. Box 503
 Delta, Alaska 99737

Amount Funded: \$3,100

Awardee will build a multi-family freezer which will store the winter's cold for summer use. It will maintain freezing temperatures for 3,000 pounds of meat or fish year-round without need of any power source whatsoever. The freezer will be a buried 14' x 14' room housing a 10 foot high, 10 foot diameter brine-filled tank. A fluid-filled convection loop will be installed in the tank and a project above ground. When the outside air is colder than the brine, the convection loop will continuously remove heat from the freezer and dissipate it above ground. The freezer will be insulated well enough to keep heat out during the summer.

JUICE BOTTLING PLANT (0107)

M. Michael Rowcroft
 c/o St. Judes Center
 3272 Hospital Drive
 Juneau, Alaska 99801

Amount Funded: \$3,250

Awardee will set up a juice processing, bottling and distributing center in Juneau. Overripe produce purchased from local markets and wholesale distributors will be processed, bottled in recycleable containers and sold to the public at reasonable cost. All processing will be performed according to the State Division of Public Health regulations -- Mr. Rowcroft is the Juneau District Sanitarian.

HYDRAULIC-POWERED AUTO (0146)

Bert Bingham
 1650 Beaver Road
 Fairbanks, AK 99701
 (Ken Kunkel)
 (Don Luterbach)
 456-2491
 452-2718 (message)

Amount Funded: \$4,045

This grant will help finance the building of an automobile with a hydraulic propulsion system. A volkswagen chassis and running gear with a sleek fiberglass body will house the low-fuel/high-energy system. The system starts with a 16 h.p. Briggs and Stratton engine. This drives a hydraulic pump. The hydraulic pump supplies charge pressure to two 5000 psi accumulators, and drive pressure to a Sunstrand hydraulic motor. The small gas engine operates at full power until the accumulators are fully charged. At that point the engine drops back to idle and the accumulator takes over. The sequence repeats automatically when the accumulators are drained to a certain level. The propulsion system, which has been previously demonstrated elsewhere, is expected to develop 75 mpg while cruising at 55 mph to 75 mph.

BEE-OVERWINTERING BUILDING (0083)

David Stoops
Mile 2.3 Kalifonsky Loop
S.R. 2, Box 707
Kasilof, Alaska 99610
Phone: 252-4904 or 262-7212
262-4904 or
262-7212

Amount Funded: \$3,775

The awardee will construct a building in which he will over-winter bees in a controlled environment. Presently, the state's 250 beekeepers have no alternative but to kill their bees each fall and face the difficulty and expense of shipping in new bees each spring.

WASTE-HEAT-CLAIMING GREENHOUSE (0029)

James Barger
Galena Regional Learning Ctr.
P. O. Box 181
Galena, Alaska 99741

Amount Funded: \$2,570

GRLC is a rural extension of the University of Alaska involved in facilitating subsistence gardening programs in 17 villages along the Yukon and Koyukuk Rivers. The group will use grant money to build a 1,500 square foot greenhouse heated by waste heat from the local power plant. The Galena Air Force Site will provide access to the glycol solution in the plant's cooling system. The hot glycol will be piped to a unit heater inside the greenhouse as well as through the soil bed of a garden behind the power plant.

SOLAR HOT WATER HEATER (0089)

Julie Scott
Camp Property Committee
c/o Box 80435
College, Alaska 99708

Amount Funded: \$1,200

Camp Bingle-Harding Lake Camp is a non-profit camp operating at Harding Lake, a recreational area 40 miles east of Fairbanks. The camp is used by various children's groups and its program is educational in nature. The staff will build a solar collector into the camp's hot water system to help offset operating expenses and incorporate energy awareness into the camp's educational program.

INSULATED SHUTTERS (0144)

Robert Walton
P. O. Box 1480
Fairbanks, Alaska 99701
Phone: 479-6838
479-6838

Amount Funded: \$1,100

The awardee will design and construct insulating shutters that can be used to cover large window areas to reduce heat loss. The shutters will take advantage of garage door technology and photoelectric or temperature sensing switches to achieve ease of operation.

TIDAL/CURRENT HYDRAULIC SUCTION DREDGE (0162)

O. Alexander Hoke
P.O. Box 963
Juneau, AK 99802
Phone: 789-0065
789-0065

Amount Funded: \$5,000

Awardee will design and develop a working model of a tidal/current hydraulic suction dredge. A tide or current powered low velocity hydraulic turbine will drive a centrifugal water pump after the high-torque, low-RPM turbine energy has been translated into low-torque, high-RPM energy by a water tight gear box. The high-velocity discharge of water will be injected through a reduction nozzle and create a vacuum at the suction head. This vacuum will lift sand and gravel through a flexible hose to a sediment stockpile on the bank. Mr. Hoke will also consider methods of achieving a regular, automatic sweep of a channel by the dredge.

SOLAR GREENHOUSE (0139)

Cyndie & Stephen Tack
S.R. Box 51113
Mile 24 Chena Hot Springs Road
Fairbanks, Alaska 99701
488-9632

Amount Funded: \$5,000

The awardees will build a greenhouse which combines several of the better greenhouse construction and energy conservation principles now in use. The structure will be similar to a large cold frame with solar storage in the back wall and in the soil. Some of the features expected to make the greenhouse free of dependence on fuel heat from mid-April to late September include:

- a) Burying to north wall and parts of the other three walls to moderate the effect of very cold and very hot weather;
- b) Using solar collectors and an underground array of pipes to heat the soil;
- c) Using a massive north wall to store heat during the day and radiate heat at night;
- d) Glazing the greenhouse with a twin-wall stressed material;
- e) Making an easily-used blanket to cover the glazed surfaces at night.

OIL FIRED CLOTHES DRYER (0145)

Mike Potter
P. O. Box 80293
Fairbanks, Alaska 99708

Amount Funded: \$500

Awardee will convert a standard household dryer from electric to oil-fired hot water heat to take advantage of the oil-fired boiler which heats his house. Hot water will be piped to a radiator core which will be mounted on the rear of the dryer; air forced across the radiator will dry the clothes. The energy requirements and cost of drying clothes with an electric dryer will be measured before the conversion; when the oil-fired system is installed, its heat requirements will also be tested.

Mr. Potter says the high cost of electricity and gas, and the fact that a large number of Alaskan homes use hot water heat suggest significant potential savings.

METHYL-FUEL PLANT (0165)

Douglas Grimm
S.E. Applied Electronics
P. O. Box 324
Auke Bay, Alaska 99821
789-2542

Amount Funded: \$5,000

The awardee will build a scale model of a system capable of accomodating the electrical and automotive energy needs of a typical urban or rural residence in southeast Alaska. The methyl-fuel plant will produce approximately one gallon of methyfuel for every 20 pounds of waste material. This project will make use of the large quantity of sawmill wood chips available in southeast Alaska. Experimentation will also be done with many other forms of "garbage." The fuel produced will then be applied to a modified 4 H.P. internal combustion engine driving an 1800 watt generator. This scale model should supply about 1/10 of the electrical energy requirement of a typical residence.

HYDROELECTRIC GENERATOR (0155)

Richard Ford
P. O. Box 158
Copper Center, Alaska 99573
344-6988 or 822-5847 (work)

Amount Funded: \$2,500

Awardee will build a small-scale hydroelectric system to reduce his family's dependence on a diesel generator. The system will be mounted on a raft in the Copper River and provide enough electricity to the residence for 8 months of the year.

WOOD FURNACE (0136)

Donald Ruef
P. O. Box 1906
Palmer, Alaska 99645

Amount Funded: \$2,150

The awardee will build, instrument and test a wood-coal furnace with a fluid-filled jacket. The fluid tube will store heat and be controlled to produce a low-pressure hot fluid and not vapor. Mr. Ruef expects the furnace to deliver 100,000 BTU/H, provide long-term even heat, require no electricity, and be marketable at less than \$1,500 each.

ELECTRIC CAR (0098)

David Grove
214 Harwood Hall
University of Alaska
Fairbanks, Alaska 99701

Amount Funded: \$5,000

Awardee will build and test an electric car for operation in cold climates. The plans for the vehicle will be purchased, but modifications will be incorporated, such as the use of light weight aircraft steel, an insulated battery compartment, and solid state devices for startup. Mr. Grove expects to demonstrate that the electric car is uniquely suited to Alaska for three reasons: first, gasoline is

generally priced higher here; second, because pollution, especially ice fog, is a serious problem; and finally, because much of Alaska's road system is disconnected, the auto's 60-mile range per charge will not be a serious limitation.

SOLAR GREENHOUSE (0074)

Jeremy & Linda Weld
P. O. Box 165
Mile 128 Ft. Richardson Highway
Gakona, Alaska 99586

Amount Funded: \$5,000

The awardees will build an add-on solar greenhouse which will utilize a thick gravel pad to store heat from the greenhouse for later use in the greenhouse and in the attained cabin. The gravel pad will be insulated from the ground around it and a heat collector at the greenhouse ridge will pump warm air into it. In addition, a rain water collection system will be incorporated into the greenhouse such that the stored water will also bank heat.

AMBULANCE SPLINT (0027)

Steve Carney
Fire Department
University of Alaska
Fairbanks, Alaska 99701
479-7535

Amount Funded: \$200

Awardee will build a modification of the long spine board used by ambulances which he expects to be an improvement. His patient stabilization system will utilize vacuum "bean bags" in conjunction with conventional straps. The vacuum bags would rely on the same principal as the vacuum splints, be adjustable, and would attach to the board with velcro.

HYDROELECTRIC GENERATOR (0129)

Ted Neville
313 Lakeview Trailer Court
Fairbanks, Alaska 99701
456-8108

Amount Funded: \$350

The awardee will build a small-scale water-powered electric generator to be powered by a river. A paddle wheel's rotation will be translated by a 2:1 ratio gearbox, and then drive an electric motor. The electric motor, when driven, produces current. Mr. Neville hopes to produce enough current to run small power tools.

SOLAR HEATER (0065)

Chris Johansen
P. O. Box 81162
College, Alaska 99708
452-2153 (work) or 479-4563

Amount Funded: \$600

Awardee will use grant money to build a simple solar air heater which could be placed in window openings. The heater would consist of a plastic panel which would admit fresh cold air from outside, allow the sun to heat it as it rises toward the window opening, and have a simple thermostatic device at the top to allow air to pass in

only when it is warmer than the ambient room temperature.

WASTE-OIL HEATER (0106)

Donald Pendergrast

Amount Funded: \$250

S.R. Box 50342

Fairbanks, Alaska 99701

Phone: 456-3516 (home) or 356-1400, ext. 428 (work)

The awardee will build a stove that burns waste crankcase oil. The stove will provide a more complete use of a scarce resource and an efficient method of waste disposal. The design utilizes a discarded electric water heater, several frying pans, and generally available and inexpensive hardware.

EXPERIMENTAL GREENHOUSES (0180)

Jim Donally & Norm Stoppenbrink

Amount Funded: \$1,000

1014 East 11th, #4

Anchorage, Alaska 99501

Phone: 277-1794 or (message) 277-4050

Awardees will build three greenhouses to test the efficiency of a plastic product, called ACPS, as a greenhouse wall material. ACPS is commercially available in long sheets or on rolls. Its common purpose is as a packing stock for fragile merchandise. It is a clear plastic film with little bubbles in it which, Mr. Donally notes, when squeezed "give a satisfying little pop." But, the bubbles also seem ideally suited to provide insulating dead air space for greenhouse walls. The first greenhouse built will have only a 6-mil visqueen covering. The second greenhouse will have ACPS, and the third, ACPS plus an insulated north wall. Maximum-minimum thermometers will be installed in each greenhouse and daily readings taken to determine the length of frost-free season.

INDUCTION GENERATOR (0506-80D)

Alakanuk City Council
 City of Alakanuk
 P. O. Box 51
 Alakanuk, AK 99554
 238-3313

Amount Funded: \$4000

The use of an Enertech 1500 wind powered generator will create an energy conservation project for remote villages, and supply power to these remote areas on an uninterrupted schedule.

SOLAR SPACE HEATER (0226-80)

Alaska Alternative Energy Resources Center
 1069 W. 6th Avenue
 Anchorage, AK 99501
 274-3621

Amount Funded: \$1500

To construct an easily adaptable solar space heater for retrofitting onto existing homes and to conduct a workshop in conjunction with the construction. The simplicity of the construction of the solar collector should be conducive to assembly by the average Alaskan homeowner. At the workshops, the retrofitting topic will be combined with a weatherization session.

FURNACE CONVERSION (0068-80)

Don Bailey
 P. O. Box 70
 Anchor Point, AK 99566
 235-8485

Amount Funded: \$400

A unique conversion - from oil to wood. The conversion of the forced air oil furnace heating system is simple and is a means of beating the high cost of oil. The existing wiring will not be touched so a circulation fan can activate at the correct temperature and continue to blow air.

TREATMENT UNIT (0312-80)

Norman Bair
 Box 10043
 Dillingham, AK 99576

Amount Funded: \$1100

To help establish state regulations for the disposal of greywater. A 30 yard septic tank would be installed outside with a gravel filter installed downline in the basement of a home. The gravel filter would further purify waste material.

BATTERY OR FUEL CELL MADE FROM SCRAP METAL (0508-80D)

Thomas R. Berson
 SR 937
 Chugiak, AK 99567

Amount Funded: \$800

To develop a cheap, long-life, high energy battery or mechanically charged fuel

cell to be made from common materials or scrap metal. This will provide an alternative power/storage supply which could replace or assist fossil fuel generators, in vehicles and in home heating systems.

WINDOW INSULATION (0036-80)

Jim Cunningham
5300 "A" Street
Anchorage, AK 99504
278-2819

Amount Funded: \$200

With the use of styrofoam panels. Students at the Specialized Academic Vocational Education Center (S.A.V.E.) will participate and earn credits. Other schools will be invited to view the panels and share the resultant data to be recorded on comparative values of these and other types of window insulation.

DOG, WATER OR WIND POWERED WASHING MACHINE (0358-80 & 0359-80)

Bill Hall
SR 1438
Eagle River, AK 99577
694-2238 (message)

Amount Funded: \$400

To be used in remote region of Skwentna. For dog power, an exercise wheel will be used to harness the dog or dogs for operating the washing machine. The method would be demonstrated at local dog mushing club meetings.

GREENHOUSE (0515-80D)

K. Quinn Hart
SR 196 H
Eagle River, AK 99577
862-5292

Amount Funded: \$2200

An energy efficient greenhouse using soil thermal mass storage and waste heat recovery on a year-round basis. In the summer months, the excess solar heat collected is transferred and stored in the soil. In the winter, waste heat from the residential coal stove is recovered to maintain soil temperatures. Upon completion of construction, a workshop will be conducted.

WIND GENERATOR (0098-80)

Steve Hicks
Box 147
Glennallen, AK 99588
822-5872

Amount Funded: \$1600

To build and demonstrate a 12 volt generator constructed from junk auto parts. The main component will be a shortened rear axle which will serve as the propeller shaft. A demonstration seminar will be conducted in Glennallen upon completion of the project.

WATERPROOFING FOR EARTH SHELTER HOUSE (0165-80)

Marnie & John Isaacs
2418 Forest Park Drive
Anchorage, AK 99503
279-8900

Amount Funded: \$3300

To utilize and test existing material "Bituthene" for waterproofing house. Bituthene is used primarily in tunnels and subways. The Isaacs wish to demonstrate that this material will be more effective and less costly than other more commonly used products.

GREENHOUSE (0055-80)

Ed Knoebel
P. O. Box 84
Glennallen, AK 99588

Amount Funded: \$4100

Knoebel has excess domestic warm water from his home heating system. He plans to recycle this water to a greenhouse as a heat method. Tests will be run for a one-year period on the practicality of growing vegetables under these greenhouse conditions.

TRAILER STEERING DEVICE (0081-80)

Alex Matheson
1817 W. 13th Avenue
Anchorage, AK 99501
388-4618

Amount Funded: \$5000

To develop a remote control rear axle steering device for truck trailers. The problem with multi/trailer rigs is maneuverability. Three trailer rigs would be used more frequently if they were more maneuverable. In addition, a moveable rear axle will eliminate the problems of backing up a multi/trailer rig.

RECYCLING ALUMINUM SCRAP (CJ85-80)

John Phillips
4211 Cope, #3
Anchorage, AK 99503
272-7992

Amount Funded: \$700

This is an alternate method of handling scrap aluminum cans and other aluminum scrap material. A small crucible furnace will transform the scrap into ingots. The ingots could be packed in a small area per unit weight for economy of shipping.

GENERATOR (0332-80)

Radio Communications Inc.
3350 Mountain View Drive
P. O. Box 98190
Anchorage, AK 99508

Amount Funded: \$5000

To construct a hybrid solar panel/wind generator system supplemented by lead-acid battery plant, that would have the capacity to power a moderate 25 Watt 12 V.D.C.

load. The proposed system would be suitable for providing power to such equipment as microwave relays, VHF/UHF communications, repeaters, hydrologic telemetering instruments and low power television translators.

SOLAR HEAT HOUSE (0072-80)

Robert Reinhardt
General Delivery
Aniak, AK 99557

Amount Funded: \$5000

Will also provide heat for hot water heating system. During winter months, additional heat will come from a modified multi-fuel stove boiler. The heat house could also be used as a fruit drying house, a greenhouse and a clothes drying area.

BOILER SYSTEM (0155-80)

Alfred Doner
SR 5620
Wasilla, AK 99687
376-5540

Amount Funded: \$1800

Design and install heat storage tank with solar assist. This will demonstrate the feasibility of year-round wood burning boiler operation. This will also demonstrate the feasibility of adding a wood or coal burning boiler in series with any existing oil or gas-fired boiler.

SOLAR WOOD DRYING KILN (0116-80)

Bruce Forster
P. O. Box 1021
Homer, AK 99603
235-7286

Amount Funded: \$3000

This is an air transfer solar kiln. Forster is a cabinet maker and would prefer using local woods which are of higher quality than imported woods. The kiln will hold up to 2000 board feet of lumber (1" thick) and is designed to dry a load in approximately one month's time. The body is a two-layer sandwich of clear fibre glass supported by four insulated walls.

WIND GENERATOR (0540-80D)

William Hightower
P. O. Box 4 (Mile 24)
Moose Pass, AK 99631

Amount Funded: \$2600

Using auto electrical parts for 12 volt wind generator to light outbuildings such as chicken house, etc. A Savenius rotor will be installed on a hill with three or four alternators attached to it. The current will be transmitted to storage batteries in the outbuilding area. When 110 volt current is needed, a power inverter will be employed.

DIGESTER (0045-80)

Edward Johnson
P. J. Box 1347
Soldotna, AK 99669
262-7941

Amount Funded: \$5000

Methane gas producing digester which will generate energy as well as dispose of waste. Waste from the digester will be transformed into fertilizer. A reinforced 2000 gallon digester in four compartments will facilitate total digestion and keep the gas supply stable.

IMPROVED WILLOW RAKE (0374-80)

Cecil R. Jones
Star Route A, Box 49A
Homer, AK 99603

Amount Funded: \$3000

Designed to speed up farm land development. It will remove willow and alder roots in the area with little disturbance to topsoil. Current methods remove excessive topsoil with removal of growth.

FRUIT AND NUT TREE CULTIVATION (0298-80)

Karen Leis
P. O. Box 923
Homer, AK 99603

Amount Funded: \$1000

To grow various fruit and nut bearing trees in remote area. Orchard is planned on a remote plateau at the head of Kachemak Bay, east of Homer. Leis is a knowledgeable grower and believes Pecan trees and other varieties of fruits and nuts will do well on the site under proper controlled growing conditions.

PERMAFROST EXCAVATION (0232-80)

Charles Posciri
SR Box 9360
Palmer, AK 99645
745-3892

Amount Funded: \$5000

A pre-facture method for excavating permafrost and rock formations. The method is designed to save on gas and oil and at the same time preserve the environment by eliminating the major portion of environmental damage normally suffered during excavation.

HYBRID ELECTRIC CAR (0281-80)

Ricardo Quiroz
P. O. Box 770
Valdez, AK 99686
835-4614 or 835-4322 Ext. 229 (work)

Amount Funded: \$2300

To modify a conventionally powered gasoline engine in a 1970 Volvo station wagon. The Volvo presently gets 16 MPG and Quiroz hopes to bring that figure up to 75 MPG. This hybrid electric propulsion system is selfcontaining and self-generating. Emphasis will be geared to learning if additional modifications will be required

to produce a hybrid electric car compatible with Alaskan weather. A 16 gallon tank should yield about 1200 miles.

PLANT HYDRO FEED SYSTEM (0290-80)

Elizaveta Shadura
P. O. Box 181
Galena, AK 99741

Amount Funded: \$5000

Using the nutrient film technique which is a streamlined version of hydroponics. A recirculating system allows a weak concentration of a complete nutrient solution to constantly run by the plant roots. This method supplies a constant flow of nutrients that can be taken up by the roots on a continuous basis.

PASSIVE SOLAR HOME PLANS (0159-80)

Steven B. Smiley
SRA Box 41-C
Homer, AK 99603

Amount Funded: \$1700

To design standard superinsulated passive solar home plans that will meet FHA approvals. It is difficult to obtain FHA approval on a "custom" looking home, rather than a conventional design. These plans will combine energy-saving features in an FHA acceptable design.

SHUTTERS FOR GREENHOUSE (0327-80)

Ak. Federation for Community Self-Reliance
P. O. Box 73488
Fairbanks, AK 99707

Amount Funded: \$1000

Insulated shutter demonstration project on site of Federations's community garden project. Roll-down quilt/type shutters in super insulated solar heated greenhouse. The system would have the advantages of light weight, low cost and esthetic appeal. Local artists will donate their time to decorate the shutters. The shutters can easily be modified for residential use.

SUBTERRANEAN OUTBUILDINGS (0130-80)

Phillip Albert
General Delivery
Ruby, AK 99768

Amount Funded: \$4800

To build subterranean area for chickens, goats, etc. on the earth surface, a greenhouse will be constructed on the top of the animal stock outbuilding. Produce for local consumption would be grown in the greenhouse. Eggs and milk would be available from the chickens and goats on a year-round basis.

SOLAR THAWING OF PERMAFROST (0044-80)

Joseph Balch
Mile 34 Salcha
Fairbanks, AK 99701

Amount Funded: \$5000

Thermal tube method using heat jacket at base of tube. Could be used for specific

research programs. With the use of a wind pump and solar collector, could possibly supply water year-round in the remote regions.

EFFECTIVE U-VALUE MEASUREMENTS (0139-80)

Axel R. Carlson
SR Box 30183 Scenic Heights
Fairbanks, AK 99702
479-6434

Amount Funded: \$5000

To develop a technique with instruments to measure the effect of thermal mass, solar orientation and color of exterior surfaces. Also to determine effective U-values (R-value) of floors, walls and roofs below grade for earth shelter homes. Will also determine the effective U-values of heavy timber and masonry of walls above grade. A computer program will be developed to convert and tabulate the data as U-values.

ARCTIC HOME CONSTRUCTION (0505-80D)

Bobby Cloyd
3750 Geist Road
Fairbanks, AK 99701

Amount Funded: \$3400

Various techniques will be implemented by the vocational carpentry class at the Hutchinson Career Center. Results will be monitored and compared for effectiveness with other types of home construction.

SOLAR GREENHOUSE (0328-80)

Michael Crawford
Box 73560
Fairbanks, AK 99707
456-6843

Amount Funded: \$4800

An air/hydronic solar collector system. An attached solar greenhouse to be constructed on the south wall of the Two Rivers Grange (Alaska #3). Labor to be donated by members. The greenhouse will be utilized by the community, including the 4H Club and other young people's organizations.

HOME ENERGY SYSTEM (0118-80)

John Dillon
Mary Moorman
P. O. Box 81123
College, AK 99708

Amount Funded: \$5000

Plan to design, build and demonstrate hybrid solar, wood and coal energy system as conservation features in a home. There will be a solar-chimney attached greenhouse with energy storage in eutectic salts. Use will be made of locally available resources to avoid rising fuel costs.

METHANE GENERATOR (0362-80)

Chris Lamb
P. O. Box 602
Nome, AK 99762

Amount Funded: \$400

Utilizing honeybuckets with a two-stage generator. The two stages allow for continuous gas production. Disposal of human waste is a major problem in northern areas. Fuel costs are high. Lamb hopes to alleviate both problems with the generator.

AUTOMATED THERMAL SHUTTERS (0309-80)

Ed McGrath
P. O. Box 80807
Fairbanks, AK 99708
452-6690

Amount Funded: \$2400

Four motor operated retrofit automated shutters when combined with 2 panes of glass have an R value of 18 - substantially higher than most insulated shutters.

TECHNIQUE FOR SHALLOW SUBSURFACE EXPLORATION (0020-80)

Robert McHattie
Richard Jurick
1921 Capitol Avenue
Fairbanks, AK 99701

Amount Funded: \$5000

To be developed with an electromagnetic solid conductivity instrument to delineate permafrost and ground ice conditions for building, map subsurface conditions and for small placer and hard rock mining operations.

GENERATING SYSTEM (0538-80D)

Carl Pelz
P. O. Box 93
Petersburg, AK 99833

Amount Funded: \$5000

A hillside stream will be the energy source. A dam will be built 200 feet above the generating system. A pipe in the dam will guarantee a steady flow of water. A Pelton wheel will be used to transmit mechanical energy from the water to the generator.

DATA RECORDING INSTRUMENT (0205-80)

James Raymond
P. O. Box 81504
Fairbanks, AK 99708
456-3128

Amount Funded: \$1100

Will build a multi-purpose instrument for recording environmental data in remote regions. The data would provide information that could help to improve the design of buildings and other projects for suitability of construction in the wilderness areas.

SOLAR ENERGY HEATING SYSTEM (0064-80)

Richard Seifert
Gary Newman
Box 80147
Fairbanks, AK 99708

Amount Funded: \$5000

To purchase two identical thermal and flow monitoring systems, two differential thermostate controllers and temperature sensors and two recording and integrating pyranometers. Seifert and Newman will monitor the systems for the lifetime of the units. Seifert's system will be heating a basement using panel heating (pipes imbedded in a concrete pad) and Newman's system will be used to provide space heating and domestic hot water heating, with additional exchangers to be used for extended gardening ground warming at a later date.

SOLAR WOOD DRYING KILN (0248-80)

Charles Simmons
Box 81724
College, AK 99708

Amount Funded: \$2000

To dry wood for use in woodworking and woodcarving. This would enable artist Simmons to utilize local rather than imported wood. The kiln will utilize fiberglass for insulation on a 2 x 4 construction, with control from thermostate operated fans.

WATER HEATING (0177-80)

Leslie A. Viereck
SR 20791
Fairbanks, AK 99701

Amount Funded: \$2000

A method for heating domestic water by a combination of wood stove and solar panels. The solar panels will heat the water from March through October and assist in heating during late fall and early spring. The project is designed to demonstrate that domestic water need not be heated by oil or electricity in the interior of Alaska.

FISH DRYING PROCESS (0145-80)

Ole Wik
Savoonga, AK 99769

Amount Funded: \$5000

A method of drying fish in a vacuum chamber, powered by existing wind electric system. The Danes use a similar process called pressfisk, where the fish is squeezed into blocks during the process.

STEAM PLANT FOR SMALL BOAT (0262-80)

Ronald Klein
P. O. Box 1587
Juneau, AK 99802
586-9492 or 465-2925/465-2944 (work)

Amount Funded: \$5000

To install and modify a commercially made steam boiler and engine for a small launch hull. To demonstrate practical use of steam as a means of locomotion, especially in the southeastern area where wood is plentiful.

1 WATT TRANSLATOR (0166-80)

David Molvik
Narrows Broadcasting Corporation
Box 149
Petersburg, AK 99833
772-3770

Amount Funded: \$5000

Translators are low power repeater stations. This would be erected on a mountain top for energy generation via solar voltaic cells for the operation of radio broadcast transmission equipment.

HOME ENERGY CONSERVATION SYSTEM (0234-80)

Jay Moor
9175 Skywood Lane
Juneau, AK 99801
789-9583

Amount Funded: \$4800

A dual domestic system comprised of heaters, controls, and environmental stabilizers that can be coordinated by means of small computer, or operated manually when the electrical power supply fails. To demonstrate the system can be packaged in modules for easy adaption to professionally built housing in Alaska.

DEVELOPMENT OF CLAM HARVESTING TECHNIQUE (063-81)

Carl DeBoard
608 Kim Place
Anchorage, AK 99504
337-3191 or 344-9602

Amount Funded: \$5000

A clam dredge that is an amphibious vehicle that will travel in 7 feet of water before it floats. It could harvest razor clams 8 months per year, for 8 hours a day. Awardee will experiment with a design modification of a clam digger he has developed. It is anticipated the clam dredge could harvest a swath 4 feet wide and have a forward speed, while harvesting of 5000 feet per hour. A beach area of 20,000 square feet per hour could be harvested.

DEVELOPMENT OF A CAM OPERATED ARCTIC DOOR DESIGN (061-81)

Phillip W. Sanders
P.O. Box 80982
Fairbanks, AK 99708
479-5920

Amount Funded: \$1100

To design a door with beveled edges and a cam operated pin hinge to eliminate the problem of air infiltration of exterior doors. Awardee will convert standard metal door. The door would revolve around one central axis. As the door is opened, the cam lift mechanism raises the door and allows it to clear the threshold. As the door closes, the cam drops the door back down on the threshold for a tight seal.

TO GROW FRUIT TREES IN THE YUKON-TANANA UPLANDS (115-81)

Bonnie Friedman
P.O. Box 81110
College, AK 99708

Amount Funded: \$1650

To coordinate the experience, research and expertise of those growing fruit trees in Alaska and to utilize those methods of growing fruit trees used in other arctic countries. To date, results are not recorded by individuals in a scientific manner and results are not passed along to other Alaskans. The grant will permit an investigation through experimentation into the response of fruit trees grown through a variety of techniques.

TO CONVERT A VW BUG TO A HYBRID-ELECTRIC VEHICLE (110-81)

W. Charles Newell
P.O. Box 80302
College, AK 99708
456-2800

Amount Funded: \$2700

To attempt to demonstrate a viable transportation design which will eliminate wasteful warm-up periods, provide reliable car service and conserve fuel emissions. The prime movers in the system would be eight 12 VDC batteries in series connection and a 2000 watt motor generator set.