

ALASKA LEGISLATURE

2241

HOUSE and SENATE FINANCE COMMITTEE FILES, 2001 - 2002

like Zoloft and Prozac are being studied in the treatment of alcoholics. Drug combinations, like the upcoming trial of naltrexone andacamprostate, could hold the most promise, allowing medications to fire at different parts of the brain's wiring at the same time.

The greatest upside of the new science may be a wider acceptance of medication as legitimate part of treatment. AA has no official policy on drugs, but a survey of 277 members in Buffalo, N.Y., found that more than half think a nonaddictive medicine that reduces the urge to drink either is a good idea or might be helpful. Only 12 percent said they'd advise someone to stop taking such a drug. And at Hazelden, the treatment center that is home of the famed "Minnesota Model" of counseling in combination with a 12-step approach, researchers are designing studies of both naltrexone andacamprostate. The pills, says research director Pat Owen, are not viewed as a threat to talk therapy, but they do raise new questions about the best approach to treatment: "People here are curious about the drugs. What will they do? What role will they play?"

Those questions point to the enormous challenges treatment providers still face. No matter how well a pill works on the brain, it still won't be able to fix complex life issues. Many people who abuse alcohol often suffer coexisting illnesses like anxiety, depression and schizophrenia; many abuse illegal drugs as well. How will one drug work when a patient is addicted to two? Simply understanding that alcoholism can be a tangle of conditions is leading to a more sophisticated concept of the disease. That could help rene the public's attitude. Now, says Parran, a lot of people still believe that the alcoholic is nothing more than a slob, a spineless, weak-willed drunk." Researchers liken alcoholism today to depression 20 years ago, before drugs like Prozac helped it be seen as a biologically based, treatable illness. "As the science marches on and treatments become better, I think you will find that the stigma will lessen," says the NIAAA's Gordis. "It's a very exciting time."

It's certainly exciting for those who have managed to win the battle. Rebecca Tucker, 23 (high-school nickname: Champagne Socky), relied on rehab and counseling to quit three years ago. "I am pro-anything that helps someone get and stay sober," she says. "Twelve-step programs, drugs, counseling—anything that can make that hellish period of early sobriety the slightest bit easier is OK by me." Straight-up wisdom: "For the millions of alcoholics still fighting the demon.

With JOAN RAYMOND, CHARLOTTE PEARSON, DAVID BRAUER, JOHN LAUERMAN, TARA WEINGARTEN and ANDREA GOETZELMANN

Know who makes all those anti-drug spots? Doesn't matter: they work. **By Devin Gordon**

THE WAR ON DRUGS GOES TO THE AIR

ANYBODY WHO'S TURNED ON A television in the past 14 years has seen the work of the Partnership for a Drug-Free America. Remember these? A girl jackknives off a diving board into an empty pool. Another bashes a kitchen to smithereens with a cast-iron pan. And, of course, a man fries an egg on a stove and explains—all together now—that this is your brain on drugs. And yet, if you ask parents and kids just who exactly the Partnership is, most of them say ... nothing. "The usual response is 'Don't know,'" says executive vice president Steve Dnistrian, smiling. "That's intentional. We don't bother with brand identity. The message is our brand."

The message is also hitting its mark. A report released last week by the National Institute on Drug Abuse found that anti-marijuana advertising has helped cut teen use by 26.7 percent. Earlier studies by the University of Michigan, New York University and Johns Hopkins each concluded that anti-drug messages have significantly reduced usage among children in every age group. The partnership does have its naysayers—new Attorney General John Ashcroft, for one, believes the campaign is a waste of federal money—but the research doesn't help their case. Says Lloyd Johnston of Michigan's Institute for Social Research: "The kids we studied were actually willing to admit that something had influenced them. I was amazed."

The partnership isn't so surprised.

Launched in 1986 by a handful of the advertising industry's finest minds, the nonprofit is in the midst of a five-year, \$1 billion joint venture with the Office of National Drug Control Policy. "And I've been ferocious in guarding those dollars," says outgoing drug czar Gen. Barry McCaffrey. The ads—created pro bono by a roster of 20 firms—reach every child in America approximately eight times a week. "The underlying theory is, 'If we can sell a product, why can't we unsell one?'" says founding member Allen Rosen-

shine, director of ad-industry titan BBDO Worldwide and chair of the partnership's star-studded creative-review board. The key, he says, is to maintain credibility: don't mislead, don't exaggerate, or kids will tune you out. That'll be critical as the partnership tackles its next challenge: ecstasy. Dnistrian admits that the party drug's sudden rise caught the group by surprise; now it's racing to come up with a response.

To get there, the partnership's 35-member permanent staff will lean heavily on its review board, which makes all creative decisions. "The crown jewel of our operation," Dnistrian calls it. "You can't buy this kind of talent. If you were IBM or Ford, you'd kill for it." Others would kill to get in front of it. For rising stars, pitching to the partnership is the ultimate job in-

terview. Says Stanley Becker of Saatchi & Saatchi: "When I see a piece of work that's really brilliant, I make a mental note of who did it." Kids, meanwhile, make a mental note of what it's saying.



AIR TIME The Partnership hits its mark by crafting artful, confrontational spots—most famously, the "brain on drugs" ad (below)

1-1-9

SENATE COMMITTEE REPORT

DATE: 4/9/01

FURTHER: Finance

DATE TURNED
IN TO OFFICE: 5-5-01

Judiciary Committee considered CS FOR HOUSE BILL NO. 172(FIN) am
THERAPEUTIC DRUG AND ALCOHOL COURTS

"An Act relating to therapeutic courts for offenders and to the authorized number of superior court judges."

and recommends:

- be replaced with 5 CS CS HB 172 (JUD)
- adopt previous CS ()
- attached amendment(s)
- adopt Letter of Intent by Committee
- further referral to Committee

Senate Bill:

- same title
- new title

House Bill:

- same title
- technical title
- new: SCR #

NEW FISCAL NOTE(S):

| Department | Date | Fiscal | Zero | FN# |
|------------|------|--------|------|-----|
| | | | | |
| | | | | |
| | | | | |
| | | | | |
| | | | | |

PREVIOUS FISCAL NOTE(S):

| Department | Date | Fiscal | Zero | F. |
|-------------|---------|--------|------|----|
| Corrections | 3/14/01 | ✓ | | 2 |
| ACS | 3/20/01 | ✓ | | 4 |
| H+SS | 3/15/01 | ✓ | | 5 |
| Admin | 4/4/01 | ✓ | | 7 |
| LAW | 4/11/01 | ✓ | | 8 |

APPROPRIATION - no fiscal note

| SIGNATURES AND RECOMMENDATIONS: | DO PASS | DO NOT PASS | NO REC | AMEND |
|---------------------------------|---------|-------------|--------|-------|
| <i>[Signature]</i> | | | X | |
| <i>[Signature]</i> | | | X | |
| <i>[Signature]</i> | X | | | |
| | | | | |
| CHAIR: <i>[Signature]</i> | ✓ | | | |

HB

175

HFIN

FILE

Adopted
4/30/02
22-LS0705\X.9
Utermohle
4/30/02

AMENDMENT 1

OFFERED IN THE HOUSE BY REPRESENTATIVE LANCASTER
TO: CSHB 175(FIN)

1 Page 1, lines 1 - 4:

2 Delete all material and insert:

3 **""An Act making an appropriation to the Alaska Energy Authority to secure**
4 **repayment of bonds for power and intertie projects; and providing for an effective**
5 **date.""**

7 Page 1, line 6, through page 3, line 28:

8 Delete all material and insert:

9 **""* Section 1. ALASKA ENERGY AUTHORITY. (a) The unobligated and unencumbered**
10 **balance of the Railbelt energy fund (AS 37.05.520) on the effective date of this Act is**
11 **appropriated to the Alaska Energy Authority for investment by the authority to secure**
12 **repayment of bonds issued by the authority under AS 44.83 for the following power and**
13 **intertie projects:**

14 (1) the sum of \$20,300,000 is allocated to upgrade and extend the Anchorage-
15 Fairbanks power transmission intertie to the Teeland substation;

16 (2) to make grants to the recipients named, for the purposes described, and in
17 the amounts set out below:

| 18 | RECIPIENT | PURPOSE | ALLOCATION |
|----|----------------------------|------------------------------|--------------|
| 19 | Homer Electric Association | replacement power supply | \$ 2,000,000 |
| 20 | | for Seldovia | |
| 21 | Anchorage Municipal | Eklutna project transmission | 19,300,000 |
| 22 | Light and Power | line upgrade | |
| 23 | Golden Valley Electric | line extension | 872,000 |
| 24 | Association | | |

1 Matanuska Electric Association line extension 500,000

2 (b) It is the intent of the legislature that, once the bonds described in (a) of this section
3 have been repaid, the Alaska Industrial Development and Export Authority will bring to the
4 legislature a prioritized list of energy projects that can be funded from the revenue stream
5 from the funds appropriated in (a) of this section.

6 * Sec. 2. LAPSE OF APPROPRIATION. The appropriation made by sec. 1(a) of this Act
7 is to capitalize a fund and does not lapse.

8 " Sec. 3. This Act takes effect immediately under AS 01.10.070(c)."
9

10 Delete funding information.

CS FOR HOUSE BILL NO. 175(2d FIN)
 IN THE LEGISLATURE OF THE STATE OF ALASKA
 TWENTY-SECOND LEGISLATURE - SECOND SESSION

BY THE HOUSE FINANCE COMMITTEE

Offered:
 Referred:

Sponsor(s): REPRESENTATIVES LANCASTER, Harris, Green, Kookesh, Mulder

A BILL

FOR AN ACT ENTITLED

1 "An Act making an appropriation to the Alaska Energy Authority to secure repayment
 2 of bonds for power and intertie projects; and providing for an effective date."

3 BE IT ENACTED BY THE LEGISLATURE OF THE STATE OF ALASKA:

4 * Section 1. ALASKA ENERGY AUTHORITY. (a) The unobligated and unencumbered
 5 balance of the Railbelt energy fund (AS 37.05.520) on the effective date of this Act is
 6 appropriated to the Alaska Energy Authority for investment by the authority to secure
 7 repayment of bonds issued by the authority under AS 44.83 for the following power and
 8 intertie projects:

9 (1) the sum of \$20,300,000 is allocated to upgrade and extend the Anchorage-
 10 Fairbanks power transmission intertie to the Teeland substation;

11 (2) to make grants to the recipients named, for the purposes described, and in
 12 the amounts set out below:

| 13 RECIPIENT | PURPOSE | ALLOCATION |
|-------------------------------|--------------------------|--------------|
| 14 Homer Electric Association | replacement power supply | \$ 2,000,000 |

| | | | |
|----|---|------------------------------|------------|
| 1 | | for Seldovia | |
| 2 | Anchorage Municipal | Eklutna project transmission | 19,300,000 |
| 3 | Light and Power | line upgrade | |
| 4 | Golden Valley Electric | line extension | 872,000 |
| 5 | Association | | |
| 6 | Matanuska Electric Association | line extension | 500,000 |
| 7 | (b) It is the intent of the legislature that, once the bonds described in (a) of this section | | |
| 8 | have been repaid, the Alaska Industrial Development and Export Authority will bring to the | | |
| 9 | legislature a prioritized list of energy projects that can be funded from the revenue stream | | |
| 10 | from the funds appropriated in (a) of this section. | | |
| 11 | * Sec. 2. LAPSE OF APPROPRIATION. The appropriation made by sec. 1(a) of this Act | | |
| 12 | is to capitalize a fund and does not lapse. | | |
| 13 | * Sec. 3. This Act takes effect immediately under AS 01.10.070(c). | | |

Replaced

No 0131
adopted 4/11/02

22-LS0705\X.4
Kurtz/Utermohle
3/26/02

AMENDMENT |

OFFERED IN THE HOUSE
TO: CSHB 175(FIN)

BY REPRESENTATIVE LANCASTER

1 Page 1, lines 1 - 4:

2 Delete all material and insert:

3 **""An Act making appropriations to the Alaska Energy Authority for power**
4 **projects, to secure repayment of bonds for power and transmission projects, and for the**
5 **power transmission intertie fund; making an appropriation to the Alaska Energy**
6 **Authority for study and construction of an electrical interconnection between Juneau**
7 **and Hoonah; and providing for an effective date.""**

8

9 Page 1, line 6, through page 3, line 28:

10 Delete all material and insert:

11 **** Section 1. ALASKA ENERGY AUTHORITY. (a) The sum of \$1,000,000 is**
12 **appropriated from the Railbelt energy fund (AS 37.05.520) to the Department of Community**
13 **and Economic Development, Alaska Energy Authority, for study and construction of an**
14 **electrical interconnection between Juneau and Hoonah as part of an intertie grid for Southeast**
15 **Alaska.**

16 (b) After the appropriation made in (a) of this section, the unobligated and
17 unencumbered balance of the Railbelt energy fund (AS 37.05.520) is appropriated to the
18 Alaska Energy Authority for investment by the authority to secure repayment of bonds issued
19 by the authority under AS 44.83 for power and intertie projects.

20 (c) The proceeds of bonds issued by the Alaska Energy Authority that are secured by
21 the amount appropriated to the Alaska Energy Authority under (b) of this section are
22 appropriated to the power transmission intertie fund.

23 (d) Contingent upon the deposit of the proceeds of the bonds described in (c) of this

1 section into the power transmission intertie fund, the sum of \$43,000,000 is appropriated from
 2 the power transmission intertie fund to the Alaska Energy Authority to be allocated for the
 3 following purposes in the amounts stated:

4 (1) the sum of \$11,000,000 is allocated to upgrade and extend the Anchorage-
 5 Fairbanks power transmission intertie to the Teeland substation;

6 (2) to make grants from the power transmission intertie fund to the recipients
 7 named, for the purposes described, and in the amounts set out below:

| 8 | RECIPIENT | PURPOSE | ALLOCATION |
|----|------------------------------|-------------------------------|--------------|
| 9 | Homer Electric Association | replacement power supply | \$ 2,000,000 |
| 10 | | for Seldovia | |
| 11 | Anchorage Municipal | Eklutna project transmission | 11,000,000 |
| 12 | Light and Power | line upgrade | |
| 13 | Copper Valley Electric | co-generation project | 5,000,000 |
| 14 | Association | | |
| 15 | Cordova Electric Association | debt reduction for the Power | 5,000,000 |
| 16 | | Creek hydroelectric project | |
| 17 | Alaska Power and | design and construction of an | 7,000,000 |
| 18 | Telephone Company | intertie between Tok and | |
| 19 | | Glennallen | |
| 20 | Kodiak Electric Association | debt reduction for Nyman | 2,000,000 |
| 21 | | combined cycle electric plant | |

22 (e) The appropriations made by (c) and (d) of this section are contingent upon the
 23 passage by the Twenty-Second Alaska State Legislature and the enactment into law of a bill
 24 establishing the power transmission intertie fund in the Alaska Energy Authority.

25 (f) It is the intent of the legislature that, once the bonds described in (b) and (c) of this
 26 section have been repaid, the Alaska Energy Authority, with the assistance of the Alaska
 27 Rural Electric Cooperative Association and the Denali Commission, prepare a prioritized list
 28 of power and transmission projects for consideration by the legislature.

29 * Sec. 2. LAPSE OF APPROPRIATIONS. (a) The appropriations made by sec. 1(b) and
 30 (c) of this Act are to capitalize funds and do not lapse.

31 (b) The appropriations made by secs. 1(a) and (d) of this Act are for capital projects

1 and lapse under AS 37.25.020.

2 * Sec. 3. This Act takes effect immediately under AS 01.10.070(c)."

3

4 Conform funding information accordingly.

Amended
Pg 2

Adopted 4/26/01

22-LS0705VT
Cramer
4/26/01

CS FOR HOUSE BILL NO. 175 (IN)
IN THE LEGISLATURE OF THE STATE OF ALASKA
TWENTY-SECOND LEGISLATURE - FIRST SESSION

BY THE HOUSE FINANCE COMMITTEE

Offered:

Referred:

| | | | |
|-----------------------------|---------------------|-----------|----------------------|
| Funding Information: | General Fund | \$ | -0- |
| | Other Funds | | 101,000,000 |
| | Total | | \$101,000,000 |

Sponsor(s): REPRESENTATIVES LANCASTER, Harris

A BILL

FOR AN ACT ENTITLED

1 "An Act making appropriations under art. IX, sec. 17(c), Constitution of the State of
 2 Alaska, from the constitutional budget reserve fund to the Alaska Industrial
 3 Development and Export Authority for power projects and to fund the power cost
 4 equalization and rural electr.c capitalization fund; and providing for an effective date."

5 **BE IT ENACTED BY THE LEGISLATURE OF THE STATE OF ALASKA:**

6 * **Section 1. ALASKA INDUSTRIAL DEVELOPMENT AND EXPORT AUTHORITY.**

7 (a) The sum of \$34,900,000 is appropriated from the constitutional budget reserve fund (art.
 8 IX, sec. 17(c), Constitution of the State of Alaska) to the Alaska Industrial Development and
 9 Export Authority, to fund the power transmission intertie fund (AS 44.83.550(a)).

10 (b) The sum of \$34,900,000 is appropriated from the power transmission intertie fund
 11 (AS 44.83.550(a)) to the Alaska Industrial Development and Export Authority, to be allocated
 12 for the following purposes:

| | | |
|----|-------------------------------------|-------------------|
| 13 | PURPOSE | ALLOCATION |
| 14 | Payment as a no-interest loan under | \$12,000,000 |

1 AS 44.83.550 (power transmission intertie
 2 loan program) to the Cordova Electric
 3 Association for completion of the Power Creek
 4 hydroelectric projec.
 5 Payment as a no-interest loan under 12,000,000
 6 AS 44.83.550 (power transmission intertie
 7 loan program) to Copper Valley Electric
 8 Association to pay capital construction debt
 9 Payment as a no-interest loan under AS 44.83.550 8,400,000
 10 (power transmission intertie loan program)
 11 to Alaska Power and Telephone Company for the
 12 acquisition, design, and construction of a power
 13 transmission intertie between Tok and Chistochina
 14 Payment as a ~~no-interest loan~~ ^{grant} under AS ~~44.83.550~~ ^{37.05.316} (power 2,500,000
 15 transmission intertie loan program) to Matanuska
 16 Electric Association for construction of a three-phase
 17 power line from Mile 100 to Mile 133 of the
 18 Parks Highway

move
 TO
 SEC
 2
 ↓

19 * Sec. 2. The sum of \$58,300,000 is appropriated from the constitutional budget reserve
 20 fund (art. IX, sec. 17(c), Constitution of the State of Alaska) to the Department of Community
 21 and Economic Development, Alaska Industrial Development and Export Authority, to be
 22 allocated for the following purposes:

| PURPOSE | ALLOCATION |
|--|------------|
| Payment as a grant under AS 37.05.316 to the Homer Electric Association for the Seldovia/Port Graham/Nanwalek regional power project | 4,800,000 |
| Extension of the Anchorage-Fairbanks power transmission intertie and upgrade of the intertie to 230 kilovolts | 24,500,000 |
| Payment as a grant under AS 37.05.316 to Copper Valley Electric Association for an intertie study | 500,000 |

| | | |
|----|--|------------|
| 1 | Payment as a grant under AS 37.05.316 to Anchorage | 25,000,000 |
| 2 | Municipal Light and Power on behalf of the Eklutna | |
| 3 | operating committee for replacing the Eklutna | |
| 4 | project power transmission line | |
| 5 | Preconstruction studies of a power transmission intertie | 1,000,000 |
| 6 | between Petersburg and Kake | |
| 7 | Preconstruction studies of a power transmission intertie | 1,000,000 |
| 8 | between Kake and Sitka | |
| 9 | Preconstruction studies of a power transmission intertie | 1,000,000 |
| 10 | between Juneau and Hoonah | |
| 11 | Study of the entire electrical grid for Southeast Alaska | 500,000 |

12 * **Sec. 3. POWER COST EQUALIZATION AND RURAL ELECTRIC**
 13 **CAPITALIZATION FUND.** The sum of \$7,800,000 is appropriated from the constitutional
 14 budget reserve fund (art. IX, sec. 17(c), Constitution of the State of Alaska) to the power cost
 15 equalization and rural electric capitalization fund (AS 42.45.100) for the power cost
 16 equalization program for the fiscal year ending June 30, 2002.

17 * **Sec. 4. CONSTITUTIONAL BUDGET RESERVE FUND.** The appropriations made by
 18 secs. 1(a), 2, and 3 of this Act are made under art. IX, sec. 17(c), Constitution of the State of
 19 Alaska.

20 * **Sec. 5. LAPSE PROVISIONS.** (a) The appropriations made by secs. 1(b) and 2 of this
 21 Act are for capital projects, lapse under AS 37.25.020, and lapse into the constitutional budget
 22 reserve fund (art. IX, sec. 17(c), Constitution of the State of Alaska).

23 (b) The appropriations made by secs. 1(a) and 3 of this Act are to capitalize funds and
 24 do not lapse.

25 * **Sec. 6. CONTINGENT EFFECT.** This Act takes effect only if the Twenty-Second
 26 Alaska State Legislature passes an Act that establishes a power transmission intertie fund and
 27 that Act becomes law.

28 * **Sec. 7.** If this Act takes effect under sec. 6 of this Act, it takes effect immediately under
 29 AS 01.10.070(c).

Alaska State Legislature

SESSION ADDRESS:
State Capitol
Juneau, Alaska 99801-1182
Phone (907) 465-2693
Toll Free 800-463-2693
Fax 907-465-3835



INTERIM ADDRESS:
35477 Suite 101-B Spur Hwy
Soldotna, Alaska 99669
Phone 907-260-5236
Fax 907-260-3044

Representative Ken Lancaster

District 8
Sponsor Statement
For
HOUSE BILL 175

"An Act making an appropriation to the Alaska Industrial Development and Export Authority for power projects;"

This bill will provide funding for five (5) energy projects. This sponsor statement provides a brief description of each project:

Power Creek Hydropower for Cordova: This is a \$24 million hydropower project being developed by Cordova Electric Association. The project has been partially funded by federal appropriations, but it needs \$12 million to cover projected debt service. Cordova is willing to forgo future involvement in the Power Cost Equalization (PCE) program in exchange for the \$12 million. Cordova is the largest recipient of PCE funds averaging approximately \$600,000 per year; this will represent considerable savings to the PCE program. This project should come on line this Spring.

Copper Valley Alternative Energy Project: The Copper Valley project consists of the Petro Star Cogeneration addition, capacity additions at Glennallen to meet rising demands, a waste heat project with the school district and reimbursement of expenses for the Department of Community and Regional Affairs intertie study. Total cost of the project is \$12.5 million. Copper Valley Electric provides power from Valdez, to Glennallen, and has the least number of customers per mile of any electric utility in Alaska. Copper Valley Electric receives no PCE assistance, yet its electricity rates are double those of other utilities on the Southcentral roadway system.

Tok/Chistochina Transmission Intertie: The project would run 83 miles along the Alaska Highway and consist of wood pole 69kilovolt (kV) line that would be operated initially at 35 kV. The cost of the project is \$8.4 million. It would reduce the cost of power from its present level of 35 cents/Kilowatt (Kw) down to 20 cents/Kw. The line would use central station generation located in Tok to bring power to the communities of Metasta, Chistochina and Slana, as well as residents along the highway and National Park Service facilities. This area represents the largest group of communities along a road system without centralized electric service. The system could ultimately be connected with the Copper Valley system 30 miles away, thus providing a link from Valdez to Tok.

Seldovia, Port Graham, Nanwalek Regional Power Project: This project would include 3.8 miles of submarine cable to interconnect remote communities on the south side of Kachemak Bay with the Homer area, and installation of remote generation at Seldovia for emergency backup. The project would include fiber optic for telecommunications. The existing submarine cable is beyond its design life and in jeopardy of failure. If the line goes down, the communities may be forced to rely on individual generation alternatives, bringing them under the PCE program. Total cost of the project is \$4.8 million.

Anchorage/Fairbanks Transmission Line Bottleneck: This project would upgrade the 26-mile segment between the 230 Kv Chugach Electric transmission system and the southern end of State of Alaska's 230 kV Anchorage/Fairbanks intertie. The line would double the power transfer capacity between Anchorage and Fairbanks, significantly reduce line losses, defer reserve additions in the system, and provide for power flows south in the event that new capacity additions are made in Fairbanks resulting from North Slope natural gas availability. Total cost of the project including substation upgrades is \$17.2 million.

Overall, this legislation will further develop electrical infrastructure in the State and enhance service to consumers.

E-Mail: Representative_Ken_Lancaster@legis.state.ak.us

Cooper Landing • Bear Creek • Funny River • Hope • Moose Pass • Ridgeway • Seward • Soldotna • Sterling
Listening to you – Getting things done.

Power Creek Hydropower Project
Cordova, Alaska

Current Situation: Cordova Electric Cooperative (CEC) presently supplies electric power to Cordova through the operation of one diesel power electric generation plant and a small hydroelectric facility on Humpback Creek. The Humpback Creek project can provide only 17 percent of the community's needs annually. CEC used 1,558,070 gallons of diesel to generate electricity in 2000, an average year. With this usage, the average cost of electricity in 1999 was 20.5 cents/kWh with residential rates of nearly 30 cents/kWh. Because of its size, Cordova is the largest recipient of Power Cost Equalization in the state, receiving an average of approximately \$600,000 annually from the program.

Project Description: The Power Creek Hydropower project, presently under construction, is licensed by the Federal Energy Regulatory Commission. Upon completion, the run-of-the-river project will have an installed capacity of 6 mw. Peak project energy will be generated during the spring, summer and fall months, time periods directly coinciding with CEC's peak demand time frame. Project construction is expected to be completed in April 2001. The project includes two Francis turbines, and power will be transported to the load center by way of a 69 kV transmission line. The project includes a river diversion structure and power penstock, but no dam or reservoir.

Cost of the System: The total cost of the project including powerhouse, penstock, intake structure, access roads, transmission line, and appurtenant structures will be \$24 million.

Benefits: The generation from the project will eliminate the need for shipment, off loading and storage of approximately one million gallons of diesel fuel per year in Cordova for an estimated annual savings of approximately \$889,100. With the requested State grant, the energy electric rate in Cordova would be 17.4 cents/kWh compared to the present average rate of 20.5 cents/kWh. In addition to the savings to Cordova, this will result in a direct reduction in the annual amount of PCE that the State pays to keep the cost of power down in Cordova. Furthermore, the plant will likely have a shelf life of at least five times that of a conventional diesel plant, resulting in savings in replacement costs in the future. The project will displace approximately 75 percent of the diesel fuel it now uses, equating to a significant reduction in the pollutants in the Cordova air shed. The resulting reduced annual emissions are approximately 250 tons in nitrogen oxide, 125 tons of sulfur dioxide and 25 tons of particulate. Finally, if the State Legislature fully funds the requested amount, Cordova is prepared to forgo future participation in the PCE program, giving the state full payback in less than ten years (considering inflation in the cost of fuel) and freeing up funds in the program for other rural communities.

Copper Valley Alternative Energy Project

Current Situation: Copper Valley Electric Association (CVEA) presently serves 7,000 residents in a geographic area approximately the size of the state of West Virginia. CVEA is a stand-alone system that transmits and distributes electricity produced at four generating plants over 380 miles of distribution line to end consumers. CVEA operates and maintains two diesel plants, a co-generation facility, and also operates the state-owned Solomon Gulch hydropower project and the related 120 miles of 138 kV transmission line that is prone to extended outages caused by avalanches. The need to install and maintain generation in both Valdez and Copper Basin districts accounts in large part for the high cost of electricity for the region. The average cost of electricity in the region is approximately twice the cost for cities and communities throughout the rest of the Southcentral road system.

In 1991, as a means to address the high costs in the region, CVEA began investigation the possible interconnection to the Railbelt utility grid. Throughout 1992 and 1993, CVEA and the AEA conducted feasibility studies to advance the project. In 1993 the Alaska Legislature authorized the project and appropriated a \$35 million, zero-interest, 50-year loan to, in part, capitalize the project. The appropriation provided the potential for meaningful rate reduction for an entire region of the state and it provided an extension of the Railbelt energy grid system. In July 1994, the commissioner of Community & Regional Affairs found that the project was economically feasible and that it could be successfully financed. During the remainder of 1994, CVEA attempted unsuccessfully to negotiate loan agreements with C&RA. In 1995 the feasibility of the project was reassessed by AIDEA, and ultimately no further progress was made in advancing the loan agreements for the project. After investing five years and \$1.3 million in study and administrative costs for the intertie project, the CVEA Board of Directors determined the project could not be advanced, and immediately began pursuit of more promising options to meet the high cost of power in its service territory.

Project Description: To address pressing power supply concerns, CVEA elected to pursue a combustion turbine co-generation project with its largest customer, the Petro Star Valdez refinery. In 1997, CVEA mounted an unsuccessful effort to secure a re-appropriation of a portion of the intertie loan to capitalize a 15-mw generation project for the region. If accomplished, that re-appropriation could have resulted in significant financial benefits for the region. After failing to receive the support from the state, CVEA scaled back the proposed project to a single 5-mw combustion turbine with a heat recovery unit. The 5-mw project was constructed and put into commercial operation on April 24, 2000. In addition to this project, new capacity addition in Glennallen is essential.

Cost of the System:

- Co-generation project cost \$7.5 million Reimbursement
- Glennallen Capacity Addition \$4.0 million
- Waste heat project with school District \$0.5 million
- Reimburse intertie DCRA study \$0.5 million Reimbursement

Page 2

Copper Valley Alternative Energy Project

The total for the Copper Valley alternative project is \$12.5 million. At the present time, Copper Valley residents receive no Power Cost Equalization assistance from the state.

Benefits: The project has numerous benefits including reduced emissions of nitrous oxide, Sulfur dioxide, and particulate matter. It uses North Slope crude oil to benefit Alaskans, and it adds a valuable increment of generating capacity to CVEA's Valdez system. In addition, through the benefits of co-generation, the project recovers heat from the combustion turbine for use in the refining process that significantly increases the overall thermal efficiency of the project. The Copper Valley/Valdez region is rich in resources and has tremendous development potential for tourism, timber, and mineral resources. Recent developments that have the potential to impact our region include straightening the Glenn highway, a major hotel project to open in 2002, the new Wrangell-St. Elias National Park Visitor Center to open in 2002, planned McCarthy road improvements, and shallow gas exploration in the Copper Basin.

Tok/Chistochina Transmission Intertie

Current Situation: Alaska Power Company (APC) provides electric service to about 1,000 customers in the close-in Tok area at an average price of 20 cents/kWh. For outlying, non-interconnected communities along the Glenn Highway such as Mentasta and Chistochina, the average cost of power is about 35 cents/kWh. Generation currently consists of a number of individual diesel generators. Consumers in this area are presently recipients of Power Cost Equalization. A reduction in the cost as a result of this project would reduce their dependence on the program. The system could ultimately be connected to the Copper valley system just 30 miles away thus providing a link from Valdez to Tok and reducing the cost of power even more.

Project Description: The project would consist of 83 miles of light transmission/heavy distribution intertie line from Tok to Chistochina. The design would be wood pole 69 kV line to be operated at 34.5 kV until interconnected with a larger system. The design includes an underbuild distribution system to be built as part of the original construction. A routing has been identified and initial discussions have been held with individual consumers, the National Park Service and the Department of Transportation.

Cost of the system: The total cost of the system with contingencies is \$8.4 million. The line will be owned and operated by APC and the construction cost will be guaranteed.

Benefits: The major benefit is the provision of reliable, more reasonably priced electric service to this area of rural Alaska through an interconnected system utilizing lower-cost generation in Tok. Power costs will be reduced from about 35 cents/kWh to about 20 cents/kWh for more than 200 homes, businesses and government facilities (including Wrangell-St. Elias National park) in the Mentasta, Chistochina and Slana areas and individual consumers in between, most of whom now self-generate. In addition, centralized electric service will facilitate economic development along this section of the Glenn Highway, including residential construction on currently undeveloped lots. Public Safety will be enhanced with a system that is in full compliance with the National Safety Code and other standards. The environment will be improved as small, less efficient generators will be replaced with central station service from Tok. There will be also be a substantial reduction in the amount of annual payments required from Alaska's Power Cost Equalization fund to support the cost of electricity in the region.

Seldovia, Port Graham, Nanwalek
Regional Power Project

Current Situation: The Homer Electric Association (HEA) service territory includes the remote communities on the south side of Kachemak Bay. Approximately 700 consumers residing principally in the communities of Seldovia, Port Graham, and Nanwalek depend upon HEA to supply electricity in this remote region. Transportation to this region is by air or boat only. Weather can significantly impact the ease of reaching this area. Flights are restricted to daylight conditions and decent visibility. Water travel is fraught with typical Alaskan ocean challenges. A 25 kV submarine cable was installed in 1975 to serve this community with power supplied wholesale from the Railbelt grid system. The cable is approximately 3.8 miles long and was designed for installation at 350 feet of water. The cable was buried at the beach 20 feet beyond mean low water level, and the portions farther out from the shore where buried by natural tidal deposition. Scour from storm activity is threatening to expose the line close to shore. Costly shore maintenance is not feasible because the line is already five years beyond its design life. Very old standby diesel generation is available in Seldovia. Current faults on the underwater cable could not only threaten the communities on the south side of the bay, but the entire Kenai system as well.

Project Description: HEA has reviewed three options to address the situation: underwater cable replacement, construction of an overhead line from Bradley Lake hydropower, and local generation. The study recommended replacing the 25 kV submarine cable and building a new standby power plant at Seldovia. The submarine cable would be 3.8 miles long and buried with non-errodable material close to the shorelines. The power plant would include four remote starting 500 kW Diesel generators, fuel holding tanks and generator building. The recommended system is the most cost-effective option and has the least risk of failing the permitting process.

Cost of the System: The cost of designing, permitting, and labor and materials for the cable crossing is estimated at \$4 million. Design and construction of the standby powerhouse is estimated at \$800,000 for a total project cost of \$4.8 million.

Benefits: The project is necessary to ensure a long-term, affordable, reliable source of electric power is available to the approximately 900 residents of the communities in the rural areas south of Kachemak Bay. Without the project, the communities will have to rely on other local sources of electricity such as costly diesel generation and perhaps the use of Power Cost Equalization.

Anchorage/Fairbanks Transmission Line Blockage

Current Situation: The interconnected transmission system between Anchorage and Fairbanks is presently owned by four entities: (1) Chugach Electric owns the 230 kV system from Anchorage to Teeland, (2) Matanuska Electric owns the 26-mile 115kv system from Teeland to Douglas (3) the Alaska Energy Authority owns the 190-mile 230 kV system from Douglas substation to Healy and is in the process of constructing a second 230 kV loop, and (4) Golden Valley Electric owns the 138 kV system from Healey to Fairbanks and is in the process of constructing a second 230kV loop. Because of the 26-mile 115 kV system bottleneck, the overall system has a transfer capability of only 70 mw of power between Anchorage and Fairbanks and the line losses across this short stretch are quite high.

Project Description: Construct a new line connecting the Chugach system (Lake Lorraine) to the State system at Douglas substation. The upgrade would double the transfer capacity between Anchorage and Fairbanks and significantly reduce line loss. From Douglas Substation on Douglas Creek, the route would follow a southeast course, generally paralleling the Parks Highway to the Nancy Lake Substation. From the Nancy Lake Substation, the route would extend due south to the Little Susitna substation on the Little Susitna River. The route would then turn to a southwest course and extend approximately 10 miles to a point southwest of Big Lake. From this point the route would follow a generally southeast course to the Lake Lorraine Substation located on the West Side of Knik Arm. Total length of the system would be approximately 26 miles consisting of Cortend steel guyed towers and conductored to operate at 230 kV.

Cost of the system: Total cost of the system based on unit costs anticipated for the Northern Intertie project presently under construction is \$17.2 million.

Benefits: Upgrade of the system would double the transfer capacity of the transmission line between Anchorage and Fairbanks. In addition to the economy energy transfer capability of the line, reserve capacity in the two load centers could be reduced, and line efficiency would be significantly increased. Future gas availability in Fairbanks could allow for siting of generation facilities or co-generation facilities in Fairbanks that would provide generation additions in the north with transfer capability south.



Homer Electric Association, Inc.

Corporate Office
3977 Lake Street
Homer, Alaska 99603-7680
Phone (907) 235-8551
FAX (907) 235-3313

Central Peninsula Service Center
280 Airport Way
Kenai, Alaska 99611-5280
Phone (907) 283-5831
FAX (907) 283-7122

January 17, 2002

RECEIVED
JAN 23 2002

The Honorable Ken Lancaster
Alaska State Legislature
State Capitol (MS-3100)
Juneau, Alaska 99801-1182

Dear Representative Lancaster:

We are very pleased to hear you are committing to another term. As state legislator, you have been very effective in representing the Kenai Peninsula. We greatly appreciate your continued support for Homer Electric's power projects.

A recent cost estimate update on the Regional Power Project for Seldovia, Port Graham and Nanwalek shows we are in need of funds beyond Senator Stevens' \$2 million grant. The following is a breakdown of costs:

| | |
|---|-----------------|
| Kachemak Submarine Cable | \$2,617,259 |
| Seldovia Generation Replacement | \$1,104,400 |
| Port Graham Stand-by Generation (new project) | \$ 255,000 |
| Sub total | \$3,976,659 |
| minus federal grant | < \$2,000,000 > |
| Net shortfall in funding | \$1,976,659 |

I look forward to working with you during the next legislative session in hopes you will be able to help with the budget shortfall. Plans are currently being made for our visit to Juneau. We look forward to visiting with you while there.

Sincerely,

HOMER ELECTRIC ASSOCIATION, INC.

A handwritten signature in black ink, appearing to read 'N. L. Story'.

N. L. Story
General Manager



Homer Electric Association, Inc.

Corporate Office
3977 Lake Street
Homer, Alaska 99603-7680
Phone (907) 235-8551
FAX (907) 235-3313

Central Peninsula Service Center
280 Airport Way
Kenai, Alaska 99611-5280
Phone (907) 233-5851
FAX (907) 283-7122

Seldovia Generator Plant Rebuild

PROJECT DESCRIPTION: Rebuild existing generation facility in Seldovia, including the building, generators, switchgear, and associated distribution equipment.

ESTIMATED COST: \$1,104,400

DISCUSSION: Although the area south of Kachemak Bay is normally served from Hatfield Substation (via Homer Spit and underwater Kachemak Bay power cable), service is frequently interrupted by tree fall during storms. In good weather this area is accessible only by air or boat. During storms the area is not safely accessible, therefore outage response by line crews is typically delayed by as many as several days. To rapidly restore power to the area (with approximately 700 consumers), HEA maintains a resident power plant operator who is on call "24/7" to operate the Seldovia generator plant during outages.

The Seldovia generation and electrical distribution system was acquired from the local electric utility in 1964. In 1970 and 1981 additional generators were installed in the generator plant. These generators are 1950's vintage and require constant attention while running. The switchgear is of similar age. A recent review has determined the building to have several problems and that it is not economically repairable.

This work plan item proposes to provide a functionally new diesel generator plant by executing the following tasks:

- Demolition of the existing building
- Removal of generators and switchgear
- Repair and reinforcement of the existing foundation
- Construction of a new building and building systems
- Installation of new generator, switchgear, and the means to remotely operate and control this equipment
- Relocation of the outdoor fuel tank to indoors
- Replacement of transformer which links the generator bus to HEA's 25 kV distribution system



Homer Electric Association, Inc.

Corporate Office
3977 Lake Street
Homer, Alaska 99603-7680
Phone (907) 235-8551
FAX (907) 235-3313

Central Peninsula Service Center
280 Airport Way
Kenai, Alaska 99611-5280
Phone (907) 283-5831
FAX (907) 283-7122

Port Graham Standby Generator

PROJECT DESCRIPTION: Provide standby generation capabilities for this remote region of the service area.

ESTIMATED COST: \$255,000

DISCUSSION: The villages of Port Graham and Nanwalek are connected by an 8.5 mile single-phase line, which comprises the most rugged and inaccessible portion of HEA's distribution system. This line is subject to storm-related outages, the restoration of which can take several days to accomplish. This project, still in the conceptual phase, proposes to provide an alternate standby means to restore power to these villages. Project will take place in the Cannery at Port Graham.

Stand Alone Generator: Stand Alone Three-Phase Generator "star-connected" - The star connection would permit a standard "off-the-shelf" 3-phase generator to reliably serve a single phase load without damage.

Additional considerations include various ways to site and provide fuel to a stand-alone generator:

- Install generator in existing Spare Bay in Cannery Generator Room
- Install generator in Separate Out-Building - this could be located near Cannery Generators or elsewhere at Port Graham
- Additional Diesel Fuel Tank
- Add piping and metering to existing Cannery Fuel Storage

As noted above, the project would install a separate generator in the Cannery building. HEA plans to conduct a study, which will consider installed cost, operations costs, ease and safety of operation with preference given to remote control, maintenance costs, ownership and lease issues.



Homer Electric Association, Inc.

Corporate Office
3977 Lake Street
Homer, Alaska 99603-7680
Phone (907) 235-8551
FAX (907) 235-3313

Central Peninsula Service Center
280 Airport Way
Kenai, Alaska 99611-5280
Phone (907) 283-5831
FAX (907) 283-7122

Submarine Cable Replacement

PROJECT DESCRIPTION: Replace aging 25kV submarine cable which supplies power to the south side of Kachemak Bay and approximately 700 consumers.

ESTIMATED COST: \$2.4 million

DISCUSSION: Dryden & LaRue, Inc. was engaged to complete an engineering study on the South Kachemak Bay power supply situation. They considered three alternatives (cable replacement, construct overhead line from Bradley Lake, and local generation), and recommend replacing the submarine cable. It is the most cost effective option.

As the existing cable was operating beyond it's expected life, a new submarine cable was ordered, shipped and ultimately installed the week of November 5, 2001.

Project estimated to cost \$2.4 million (actual cost \$2,401,782)

Additional work to tie newly installed submarine cable to the HEA distribution system at the Homer Spit. (actual cost \$215,477)

| | |
|------------------------------|--------------------|
| Submarine cable installation | \$2,401,782 |
| Termination work | \$215,477 |
| Total | \$2,617,259 |

Copper Valley Electric Association, Inc.
Cogeneration Project-Emissions Benefits
March 26, 2002

The Cogeneration Project

Copper Valley Electric Association (CVEA) and Petro Star Valdez Refinery jointly developed a Cogeneration facility, which began commercial operation in April of 2000. The facility combines electric power generation with the refining process to achieve high fuel efficiencies and reduced air emissions.

CVEA owns and operates a 5-megawatt combustion turbine located adjacent to Petro Star's Valdez Refinery. The turbine supplies power into CVEA's grid, powering homes and business in Valdez and the Copper River Basin regions of Alaska. The turbine's fuel source is Light Straight Run (LSR), which is supplied from the refinery.

The turbine's exhaust is connected to Petro Star's crude oil heater. Heat from the exhaust is recovered in the crude heater, reducing Petro Star's fuel requirement to heat oil for the refining process. With the turbine operating Petro Star can more efficiently refine Alaskan crude for Alaskans.

The overall fuel efficiency of the cogeneration process is approximately 70%.

Cogeneration Emissions Benefits

The Cogeneration project has realized outstanding air emissions reductions. The reduction in emissions exceeds 750 tons per year when compared to power generation at CVEA's diesel plants, and when compared to operating the refinery without the cogeneration process. This reduction is attributed to the following facts:

- Turbine emissions are much lower than the alternative power generation source, which is reciprocating diesels. (Glennallen and Valdez diesel plants)
- The LSR fuel, available only at the refinery has less sulfur than the diesel fuel used at the reciprocating diesel power plants.
- Heat from the turbine's exhaust is recovered in the crude heater, reducing the crude heater's fuel consumption.
- Utilizing turbine exhaust as crude heater combustion air causes the crude heater's production of NOx to decrease significantly.

Conclusion

- The cogeneration project provides significant emission benefits in Valdez and the Copper River Basin by displacing 5 megawatts of reciprocating diesel generation.
- The net reduction in measured pollutants is 786 tons per year.
- The net reduction in NOx emissions at the refinery is 21 tons per year.

Power Creek Hydropower Project
Cordova, Alaska

Current Situation: Cordova Electric Cooperative (CEC) presently supplies electric power to Cordova through the operation of one diesel power electric generation plant and a small hydroelectric facility on Humpback Creek. The Humpback Creek project can provide only 17 percent of the community's needs annually. CEC used 1,558,070 gallons of diesel to generate electricity in 2000, an average year. With this usage, the average cost of electricity in 1999 was 20.5 cents/kWh with residential rates of nearly 30 cents/kWh. Because of its size, Cordova is the largest recipient of Power Cost Equalization in the state, receiving an average of approximately \$600,000 annually from the program.

Project Description: The Power Creek Hydropower project, presently under construction, is licensed by the Federal Energy Regulatory Commission. Upon completion, the run-of-the-river project will have an installed capacity of 6 mw. Peak project energy will be generated during the spring, summer and fall months, time periods directly coinciding with CEC's peak demand time frame. Project construction is expected to be completed in April 2001. The project includes two Francis turbines, and power will be transported to the load center by way of a 69 kV transmission line. The project includes a river diversion structure and power penstock, but no dam or reservoir.

Cost of the System: The total cost of the project including powerhouse, penstock, intake structure, access roads, transmission line, and appurtenant structures will be \$24 million.

Benefits: The generation from the project will eliminate the need for shipment, off loading and storage of approximately one million gallons of diesel fuel per year in Cordova for an estimated annual savings of approximately \$889,100. With the requested State grant, the energy electric rate in Cordova would be 17.4 cents/kWh compared to the present average rate of 20.5 cents/kWh. In addition to the savings to Cordova, this will result in a direct reduction in the annual amount of PCE that the State pays to keep the cost of power down in Cordova. Furthermore, the plant will likely have a shelf life of at least five times that of a conventional diesel plant, resulting in savings in replacement costs in the future. The project will displace approximately 75 percent of the diesel fuel it now uses, equating to a significant reduction in the pollutants in the Cordova air shed. The resulting reduced annual emissions are approximately 250 tons in nitrogen oxide, 125 tons of sulfur dioxide and 25 tons of particulate. Finally, if the State Legislature fully funds the requested amount, Cordova is prepared to forgo future participation in the PCE program, giving the state full payback in less than ten years (considering inflation in the cost of fuel) and freeing up funds in the program for other rural communities.

Tok to Chistochina Distribution System - \$8.4 Million

Electric service is the most basic form of infrastructure, because even other essential services such as water and sewer are dependent on it. Providing lower cost, more reliable electricity to those areas of rural Alaska where power costs are extremely high is an especially worthy public interest purpose.

Current System

Alaska Power Company (APC), the wholly owned retail electric subsidiary of Alaska Power & Telephone Company, provides electric service to about 1,000 customers in the close-in Tok Area at an average price of 20 cents/kWh. For outlying, non-interconnected communities along the Glenn Highway such as Mentasta and Chistochina, the average cost of power is about 35 cents/kWh.

Project Description

The project will consist of 83 miles of light transmission/heavy distribution intertie line from Tok to Chistochina. The design is a wood pole 69kV line to be operated at 34.5 kV until interconnected with a larger system. The design includes an underbuild distribution system to be built as part of the original construction. A routing has been identified and initial discussions have been held with individual consumers, the National Park Service and the Alaska Department of Transportation/Public Facilities. Based on the discussions, there appears to be broad support of a Tok-Chistochina intertie.

Cost of System

The total cost of the system with contingencies is \$8.4 million. APC will own, operate and maintain the system. AP&T will guarantee the construction costs.

Public Interest Benefits

The major benefit is the provision of reliable, more reasonably priced electric service to this area of rural Alaska through an interconnected system utilizing lower-cost generation in Tok. Power costs will be reduced from about 35 cents/kWh to about 20 cents/kWh for more than 200 homes, businesses and government facilities (including Wrangell-St. Elias National Park) in the Mentasta, Chistochina and Slana areas and individual consumers in between, many of whom now self-generate. In addition, centralized electric service will facilitate economic development along this section of the Glenn Highway, including residential construction on currently undeveloped lots.

Public safety will be enhanced with a system that is in full compliance with the National Electric Safety Code and other standards. The environment will be improved as small, less efficient generators are replaced with central station service from Tok. There will also be a substantial reduction in the amount of annual payments required from Alaska's Power Cost Equalization Fund to support the cost of electricity in the region.

Tok to Glennallen Intertie - \$14.5 Million

Extending this project from Chistochina to Glennallen would provide interconnection between APC and Copper Valley Electric Association (CVEA). APC estimates the cost of the entire intertie from Tok to Glennallen to be approximately \$14.5 million. This cost would vary depending on how much of the project would be completed by APC versus CVEA.

KODIAK ELECTRIC ASSOCIATION, INC.

Kodiak Electric Association is committed to providing safe, reliable energy and a high level of service excellence to enhance the quality of life of its members and of the community.

Kodiak Electric Association, Inc. (KEA) is requesting a grant or zero interest loan to finance the electrical portion of a combined cycle electric generation and heating plant on the United States Coast Guard Integrated Support Command Kodiak base. KEA has invested \$13.3 million dollars to build the Nyman Plant in a committed effort to maintain a stable electrical generation platform for Kodiak and to meet the projected growth of our community's energy needs. The electrical portion of the Nyman Plant is \$10 million dollars.

About Kodiak, Alaska...

Kodiak is part of the Kodiak Island Archipelago, a group of islands that parallels the Katmai Coast along the Alaska Peninsula for roughly 177 miles in the Gulf of Alaska. Approximately 200 miles south of Anchorage, this location in the Gulf of Alaska and the North Pacific Ocean is near some of the richest fishing grounds in the world. Kodiak is the center of fishing activities for the Gulf of Alaska and is consistently one of the top fishing ports in the United States in terms of value of seafood landed. More than half of the jobs in Kodiak are directly involved in the fishing industry, in either the harvesting or processing sectors.

Kodiak Electric Association, Inc. is owned by the members we serve.

Kodiak Electric Association, Inc. (KEA) is a member-owned rural electric cooperative serving 3,568 members (5,606 meters) located in the City of Kodiak, United States Coast Guard (U.S.C.G.) Integrated Support Command Kodiak, Bells Flats/Russian Creek area, Chiniak/Pasagshak, and Port Lions. The Cooperative currently maintains 12.25 transmission miles, 180.35 overhead distribution miles, and 118.21 underground distribution miles. Since the Articles of Incorporation were drawn up in 1941, KEA's Board of Directors and staff have worked diligently to meet the growing energy needs of Kodiak's population. Over the years, this commitment to the community has resulted in the addition of new diesel generating facilities, transmission, substation and distribution systems and operation and maintenance of the Terror Lake Hydroelectric Project. KEA's newest commitment to the community is the Nyman Combined Cycle Project located in the Nyman Power Plant on the U.S.C.G. Integrated Support Command Base.

Nyman Combined Cycle Plant – Our Newest Community Commitment

The Nyman Combined Cycle Cogeneration Plant became operational on January 14, 2000 with a ten-year contract with the U.S.C.G. Since then, it has produced over 25% of the electrical requirement for the community of Kodiak. The main components are a 5.5 megawatt combustion turbine, a heat recovery steam generator, and a 1.5 megawatt steam turbine. The plant's primary focus is electrical generation with the waste heat generating steam. This steam can be sent to the U.S.C.G base for heating, sent to the steam turbine for additional electrical generation, or a combination of both. The project cost of \$13.3 million was funded through the use of equity and an eight million dollar loan from the Rural Utilities Service.

Why was the Nyman Combined Cycle Cogeneration Plant built?

KEA's most recent Power Requirement Study showed the need for additional generation capacity. The Terror Lake Hydroelectric Power Plant, our largest generator, produced 20 megawatts (MW). The remainder of generation was provided by aged diesels. The study highlighted two growing concerns for KEA: the need to supply adequate generation for Kodiak's load growth, and the need to provide a stable electrical system for the periods when the Terror Lake Plant requires repair or is operating at reduced loads due to low lake water level.

- ◆ Electrical load growth in Kodiak grew at an average of 5% per year from January 1998 through August 2000.
- ◆ In January 1999, KEA experienced an all-time high system peak power demand of 22.67 MW, and the community used 3.2% more energy than in 1998.
- ◆ In February 2000, demand for electrical power hit the new all-time peak demand of 24.06 MW, which was a 7% increase over the 1999 peak demand. This all-time peak is an increase of 100% over the 1983 power demand.
- ◆ In 2000, the Terror Lake Project was shut down for over 100 days during extensive scheduled tunnel repairs by the State of Alaska, and also experienced record low lake water levels.

Various options of generation were studied and discussed. The combined cycle combustion turbine option with the ability to supply steam to the U.S.C.G.

base or a steam turbine located on the U.S.C.G. base was determined to be the best answer for the Kodiak community.

- ◆ Combined cycle technology was a more efficient use of diesel fuel than contemporary diesel generation.
- ◆ Combined cycle technology provides environmentally cleaner electricity and reduced emissions than contemporary diesel generation.
- ◆ The Combined cycle project allows a higher degree of reliability to the U.S.C.G.
- ◆ The Combined cycle process allows waste heat to be utilized by supplying steam to the U.S.C.G. to heat facilities.
- ◆ Combustion turbines have lower long-term maintenance costs than diesels.
- ◆ It is not necessary to man the combined cycle plant on a twenty-four hour basis, resulting in a savings of labor dollars.

Nyman Plant Production to Date

- ◆ Produced 29% and 49,371,400 kWhs in 2000; produced 21% and 29,164,400 kWhs in 2001.
- ◆ Helped "keep the lights on" in our community during the State of Alaska's 100-day Terror Lake shutdown for scheduled repair work and during low water levels in Terror Lake in 2000. Again helped "keep the lights on" during the State of Alaska's 40-day Terror Lake shutdown for scheduled repair work in 2001.

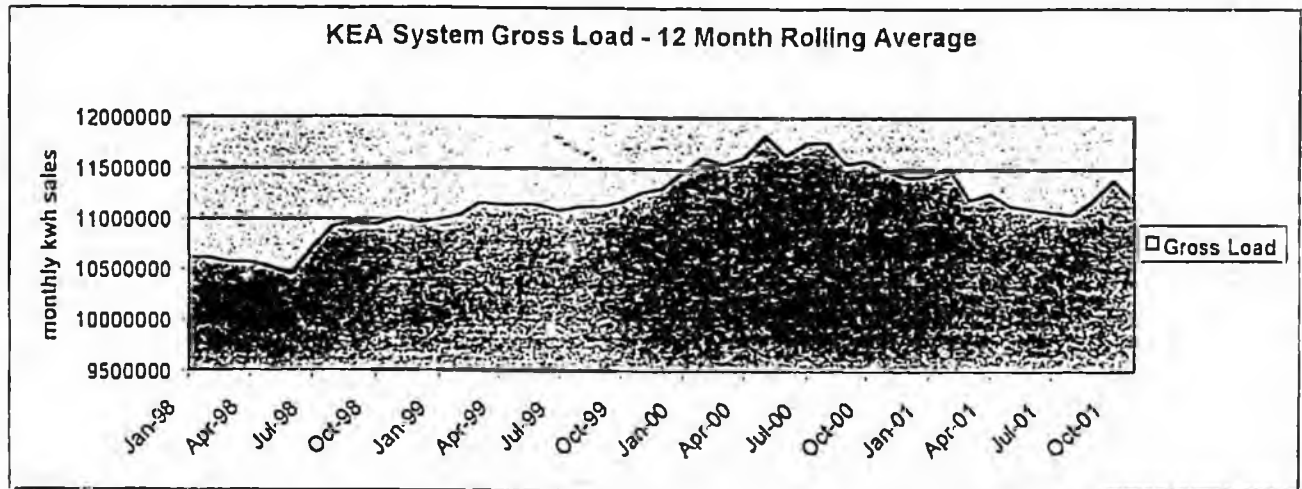

Figure 1

What significant changes are affecting or have affected the electrical load in the Kodiak community?

U.S. District Court Judge Zilly's ruling in effect on August 8, 2000 placed a fishing injunction on the Alaska trawl fleets, closing all fishing inside Steller sea lion critical habitat (inside 20 nautical miles). Because only 5% of the Pollock biomass is found outside 20 nautical miles, 15,000 metric tons (MT) of Pollock quota that would have been delivered to the port of Kodiak were left in the water during the C season (August 20) and D season (September 15).

The reduction in Pollock landings had a major negative economic impact on the Kodiak fishing industry as well as industry support businesses. Energy usage by the seafood processors dropped substantially. The Kodiak maximum processing capacity is 1,000 to 1,200 MT per day, so the loss of 15,000 MT of Pollock represents 15 days of maximum electrical usage for the processing sector in 2000. The result was a dramatic decrease in KEA's power production and a corresponding drop in KEA's

revenue. An estimated six million kWhs were not generated and sold, for a total net earnings loss of \$422,587. KEA ended the year 2000 with less than 1% load growth for the year.

The 2001 federal fisheries, which contribute to the Port of Kodiak's landings, have lost ground when compared to the 2000 fishery structure. Regulations for the first six months of 2001 established two fishing seasons for Pacific cod, reducing the January 1 allocation from the traditional 80% of the total allowable catch to 60%. The total allowable catch for Gulf of Alaska Pollock was reduced 10%.

The most recent Power Requirement Study also projected load growth for the Kodiak community. Figure 1 shows load growth from 1998 to the summer of 2000 to be 10%. However, in August of 2000, the load growth and average demand began to decline, at an average rate of 8%. This decline is just eight months after bringing the Nyman Plant on line. The 2001 highest peak demand through June 2001 was 23.5 MW, in February.

The drop in load growth is directly attributed to the fishing injunction on the Alaska trawl fleets and the general decline in the Pollock fishery.

Overall Decline in Fishing Industry

The Pollock/trawl fishery is not the only fishery to have been negatively impacted recently – the Salmon fisheries have also been impacted. The world market is now flooded with farmed Salmon, causing prices for wild and farmed Salmon to downward spiral. The impact to Alaskan fisheries still has not been fully realized, but it continues to grow in a negative direction. Farmed Halibut is now being tested, and this development may spell problems for Alaska's Halibut fishery in the future.

Overall, the fishing industry is in a tenuous state; in Kodiak, the industry is directly impacted by the price of electricity used to process product.

What options to maintain healthy margins does KEA have?

KEA is working diligently to avoid a rate increase. Our community already suffers from very high electrical rates - the current rate for residential consumers is \$0.1380 per kWh. Our last rate increase of 5.39% was implemented in 1994. A 1.84% rate decrease was implemented in 1997, and there have not been any other changes to base rates since that time.

The Cooperative recently cut costs through a reorganization effort that resulted in the reduction of three full-time positions. We are also diversifying

our business to enhance our revenue. In 2000, KEA brought cellular service to the island through a partnership with New Horizons, Inc., an Alaskan company based in Palmer, Alaska. These efforts have all been successful, but it will require time for the savings and revenue to have an impact on KEA's margins.

KEA has invested \$13.3 million dollars to enhance the quality of life in our community by meeting carefully projected energy needs. This generation will be needed in the future. However, the Nyman Plant has put a serious drain on KEA resources because of the decline of electrical sales growth in the community.

How can the Alaska State Legislature make a positive impact on KEA and Kodiak Island residents?

KEA would respectfully request a grant or zero interest loan from the State of Alaska for the dollars invested in the Nyman Plant. The savings from this grant or loan will allow KEA to maintain rate stability, and avoid the negative impact a rate increase would have on our community and local economy.

Kodiak is experiencing an economic recession. It will take the community some time to recover, and there will be a continuing impact on KEA's load growth and generation sales.

An increase in electrical rates would impact every resident and every business. The Alaska State Legislature can make a difference in our community.

Anchorage/Fairbanks Transmission Line Blockage

Current Situation: The interconnected transmission system between Anchorage and Fairbanks is presently owned by four entities: (1) Chugach Electric owns the 230 kV system from Anchorage to Teeland, (2) Matanuska Electric owns the 26-mile 115kV system from Teeland to Douglas (3) the Alaska Energy Authority owns the 190-mile 230 kV system from Douglas substation to Healy and is in the process of constructing a second 230 kV loop, and (4) Golden Valley Electric owns the 138 kV system from Healey to Fairbanks and is in the process of constructing a second 230kV loop. Because of the 26-mile 115 kV system bottleneck, the overall system has a transfer capability of only 70 mw of power between Anchorage and Fairbanks and the line losses across this short stretch are quite high.

Project Description: Construct a new line connecting the Chugach system (Lake Lorraine) to the State system at Douglas substation. The upgrade would double the transfer capacity between Anchorage and Fairbanks and significantly reduce line loss. From Douglas Substation on Douglas Creek, the route would follow a southeast course, generally paralleling the Parks Highway to the Nancy Lake Substation. From the Nancy Lake Substation, the route would extend due south to the Little Susitna substation on the Little Susitna River. The route would then turn to a southwest course and extend approximately 10 miles to a point southwest of Big Lake. From this point the route would follow a generally southeast course to the Lake Lorraine Substation located on the West Side of Knik Arm. Total length of the system would be approximately 26 miles consisting of Cortend steel guyed towers and conductored to operate at 230 kV.

Cost of the system: Total cost of the system based on unit costs anticipated for the Northern Intertie project presently under construction is \$17.2 million.

Benefits: Upgrade of the system would double the transfer capacity of the transmission line between Anchorage and Fairbanks. In addition to the economy energy transfer capability of the line, reserve capacity in the two load centers could be reduced, and line efficiency would be significantly increased. Future gas availability in Fairbanks could allow for siting of generation facilities or co-generation facilities in Fairbanks that would provide generation additions in the north with transfer capability south.

Railbelt Transmission Line Upgrade **Twenty-six mile upgrade to 230 kv**

Current Situation: The interconnected transmission system between Anchorage and Fairbanks is presently owned by four entities: (1) Chugach Electric owns the 230 kv system from anchorage to Teeland, (2) Matanuska Electric owns the 26 mile 115kv system from Teeland to Douglas (3) the Alaska Energy Authority owns the 190 mile 230 kv system from Douglas substation to Healy and is in the process of constructing a second 230kv loop, and (4) Golden Valley Electric owns the 138 kv system from Healey to Fairbanks and is in the process of constructing a second 230kv loop. Because of the 26 mile 115 kv system, the overall system has a transfer capability of only 70 mw of power between Anchorage and Fairbanks and the line losses across this short stretch are quite high.

Proposal Construct a new line connecting the Chugach system (Lake Lorraine) to the State system at Douglas substation. The upgrade would double the transfer capacity between Anchorage and Fairbanks and significantly reduce line loss. From Douglas Substation on Douglas Creek, the route would follow a southeast course, generally paralleling the Parks Highway to the Nancy Lake Substation. From the Nancy Lake Substation, the route would extend due south to the Little Susitna substation on the Little Susitna River. The route would then turn to a southwest course and extend approximately 10 miles to a point southwest of Big Lake. From this point the route would follow a generally southeast course to the Lake Lorraine Substation located on the West Side of Knik Arm. Total length of the system would be approximately 26 miles consisting of Cortend steel guyed towers and conductored to operate at 230 kv.

Cost of the system: Total cost of the system based on unit costs anticipated for the Northern Intertie project presently under construction is \$17.2 million.

Benefits: Upgrade of the system would double the transfer capacity of the transmission line between Anchorage and Fairbanks. In addition to the economy energy transfer capability of the line, reserve capacity in the two load centers could be reduced, and line efficiency would be significantly increased. Future gas availability in Fairbanks could allow for siting of generation facilities or co-generation facilities in Fairbanks that would provide generation additions in the north with transfer capability south.

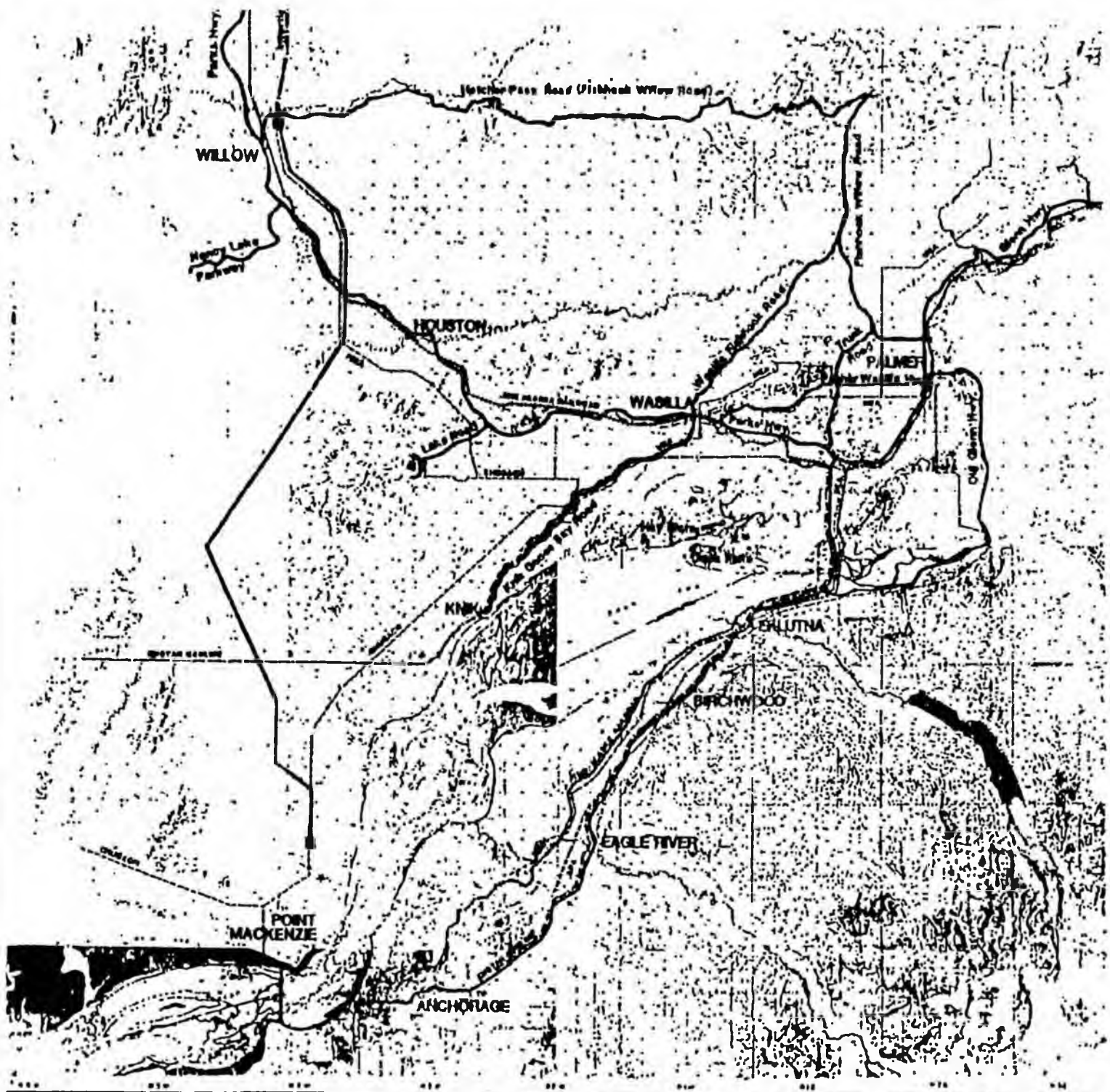

DATA SOURCE

- USGS 1:50,000 Topographic Map
- LORRAINE

LEGEND

- Major Highways & Roads
- Interim
- District Center
- Existing Transmission Lines
- Railroad
- ⊙



ALASKA POWER AUTHORITY

ALASKA - FAIRBANKS DISTRICT

**PROPOSED ROUTE
DOUGLAS - LAKE
LORRAINE**

Map 2 6000 07

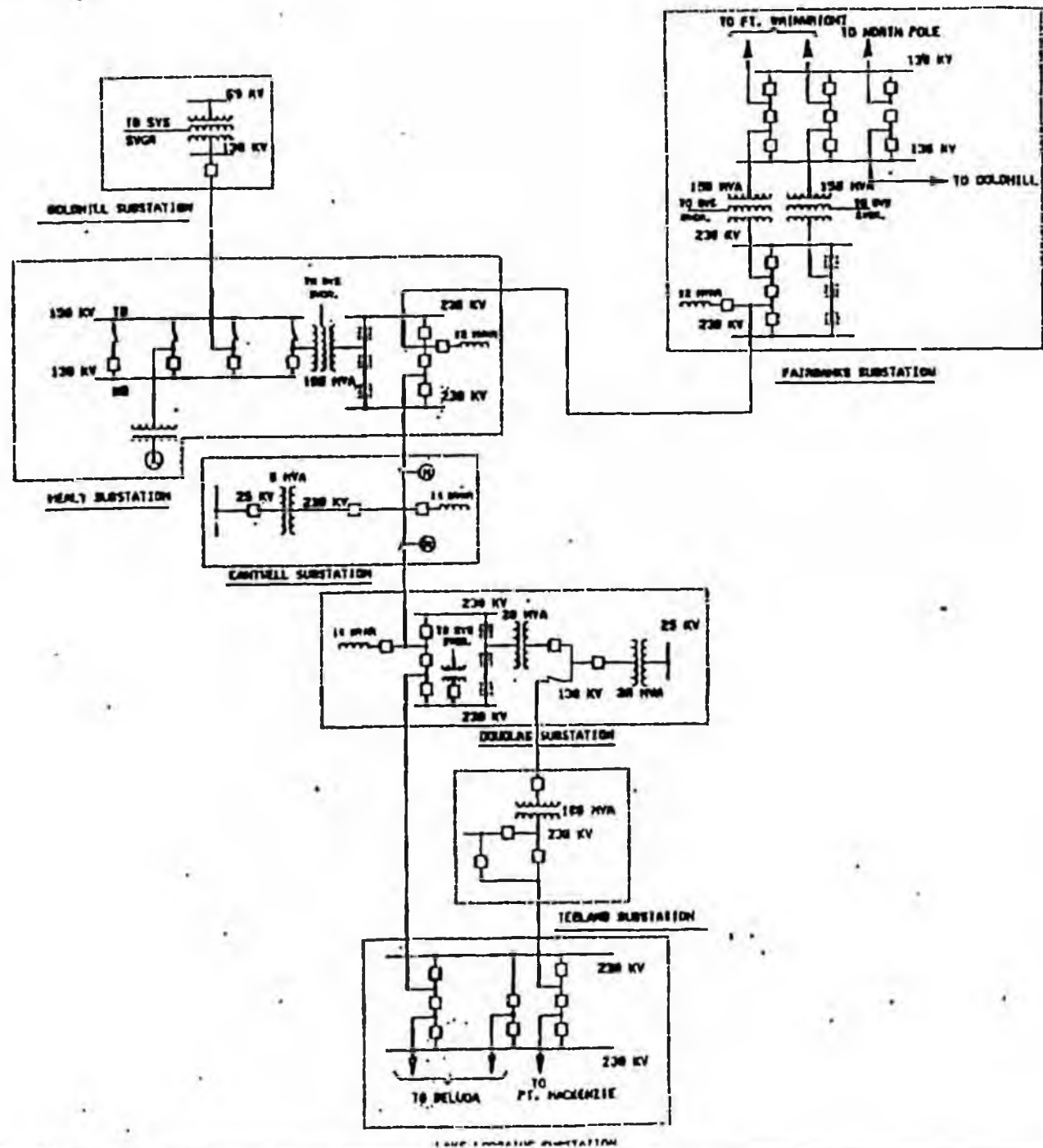

ALASKA POWER AUTHORITY
 ANCHORAGE - FAIRBANKS
 INTERTIE
 SYSTEM DIAGRAM

ALASKA POWER AUTHORITY - FAIRBANKS OPERATIONS

ID: 9874515618

PAGE 22/22

March 13, 2001

230 kilovolt Conversion of the Anchorage to Fairbanks Intertie

The existing intertie from Willow to Healy is constructed to operate at 345 kilovolts and is currently operating at 138 kilovolts. The Northern Intertie will be constructed to operate at 230 kilovolts and will operate in parallel with the existing 138 kV line between Healy and Fairbanks. Adding a new 26 mile 230 kV line from the Douglas substation in Willow to Teeland Substation in Wasilla would provide a 230 kV source to the north.

CAPITAL COSTS:

| | |
|---|----------------------|
| Cost Estimate for Fairbanks to Healy 230 kV Conversion | |
| Transmission Line Design, Permitting, Construction | |
| 26 miles at \$520,000 per mile | \$ 13,520,000. |
| <u>Conversions and transformers at multiple substations</u> | <u>\$ 11,008,000</u> |
| Total costs of 230 kV Conversion | \$ 24,528,000 |

BENEFITS:

Increased Transmission Capacity

Purchases from Anchorage (current): The transfer capacity in to Healy would increase from 70 megawatts to approximately 130 megawatts after the conversion to 230 kilovolts. The increase in transfer capacity would provide access to new or existing gas-fired cogeneration in Anchorage.

Sales to Anchorage (Post gas-pipeline): Power can flow either direction on transmission lines. The transmission capacity increase will allow for delivery of 130 megawatts of North Slope gas-fired power to Anchorage, after construction of the gas pipeline.

Reduced Transmission Line Losses

Teeland to Douglas Line: From operation of a new parallel path at 230 kV

Douglas to Healy: From voltage conversion from 138 kV to 230 kV

Healy to Fairbanks: From Northern Intertie parallel path and conversion of the Northern Intertie to operate at 230 kV.

Reliability Increases -- Second Line Douglas to Teeland: The addition of a second circuit will improve reliability across this section of line which is prone to line failures.

Reconstruction Benefits: The addition of the second line will allow for maintenance of either line while maintaining power delivery.

230KV Upgrade Cost Estimate

4/3/01

BUSWORK

| Item | Quantity | Unit | Material Cost | Mat Cost Per Unit | Installation Cost | Inst Cost Per Unit | Total Cost |
|---|----------|------|---------------|-------------------|-------------------|--------------------|--------------|
| INSULATOR, STATION POST, 230KV | 204 | ea | \$190.00 | \$38,760.00 | \$355.00 | \$72,420.00 | \$111,180.00 |
| INSULATOR, STATION POST, 138KV | 42 | ea | \$105.00 | \$4,410.00 | \$355.00 | \$14,910.00 | \$19,320.00 |
| INSULATOR, SUSPENSION, 230KV | 115 | ea | \$180.00 | \$20,700.00 | \$540.00 | \$62,100.00 | \$82,800.00 |
| INSULATOR, SUSPENSION, 138KV | 6 | ea | \$120.00 | \$720.00 | \$540.00 | \$3,240.00 | \$3,960.00 |
| SURGE ARRESTER, STATION CLASS, 230KV MCOV | 20 | ea | \$1,750.00 | \$35,000.00 | \$1,680.00 | \$33,600.00 | \$68,600.00 |
| SURGE ARRESTER, STATION CLASS, 138KV MCOV | 8 | ea | \$1,010.00 | \$8,080.00 | \$1,680.00 | \$13,440.00 | \$21,520.00 |
| CONDUCTOR, PIPE, 4" ALUMINUM, SCHEDULE 40 | 2000 | lf | \$12.00 | \$24,000.00 | \$13.00 | \$26,000.00 | \$50,000.00 |
| CONDUCTOR, PIPE, 2" ALUMINUM, SCHEDULE 40 | 2000 | lf | \$8.00 | \$16,000.00 | \$13.00 | \$26,000.00 | \$42,000.00 |
| CONDUCTOR, CABLE | 1000 | lf | \$2.00 | \$2,000.00 | \$6.00 | \$6,000.00 | \$8,000.00 |
| PIPE CONNECTORS, MISC | 500 | ea | \$15.00 | \$7,500.00 | \$43.00 | \$21,500.00 | \$29,000.00 |
| CABLE CONNECTORS, MISC | 100 | ea | \$35.00 | \$3,500.00 | \$16.00 | \$1,600.00 | \$5,100.00 |
| TOTALS | | | | \$160,670.00 | \$280,810.00 | \$441,480.00 | |

230KV Upgrade Cost Estimate

4/3/01

| Item | Quantity | Unit | Material Cost | Installation Cost | Total Cost |
|--------------------|-----------------|-------------|----------------------|--------------------------|------------------------|
| EQUIPMENT | 1 | lump | \$4,080,500.00 | \$662,880.00 | \$4,743,380.00 |
| STRUCTURES | 1 | lump | \$307,395.00 | \$456,632.00 | \$783,107.00 |
| BUSWORK | 1 | lump | \$160,670.00 | \$280,810.00 | \$441,480.00 |
| FOUNDATIONS | 1 | lump | \$780,192.00 | \$815,410.00 | \$1,595,602.00 |
| GROUNDING | 1 | lump | \$31,570.00 | \$197,100.00 | \$228,670.00 |
| PROTECTIVE RELAYS | 1 | lump | \$250,000.00 | \$120,000.00 | \$370,000.00 |
| CONDUIT AND CABLES | 1 | lump | \$289,500.00 | \$156,000.00 | \$445,500.00 |
| SITE PREPARATION | 600000 | sf | \$1.50 | \$1.00 | \$1,500,000.00 |
| CRUSHED ROCK | 600000 | sf | \$1.00 | \$0.50 | \$900,000.00 |
| TOTALS | | | | | \$11,007,739.00 |

230KV Upgrade Cost Estimate

4/3/01

| EQUIPMENT Item | Quantity | Unit | Material Cost | Mat Cost Per Unit | Installation Cost | Inst Cost Per Unit | Total Cost |
|---|----------|------|---------------|-------------------|-------------------|--------------------|----------------|
| POWER TRANSFORMER: 230/138KV, 150MVA | 1 | ea | \$750,000.00 | \$750,000.00 | \$126,780.00 | \$126,780.00 | \$876,780.00 |
| POWER TRANSFORMER: 230/138KV, 100MVA | 1 | ea | \$650,000.00 | \$650,000.00 | \$126,780.00 | \$126,780.00 | \$776,780.00 |
| POWER TRANSFORMER: 230/24.9KV, 12/16/20MVA | 1 | ea | \$380,000.00 | \$380,000.00 | \$72,450.00 | \$72,450.00 | \$452,450.00 |
| POWER TRANSFORMER: 230/24.9KV, 6.25MVA | 2 | ea | \$345,000.00 | \$690,000.00 | \$52,450.00 | \$104,900.00 | \$794,900.00 |
| POWER CIRCUIT BREAKERS 230KV, SF6, 1200 AMP | 10 | ea | \$89,000.00 | \$890,000.00 | \$10,920.00 | \$109,200.00 | \$999,200.00 |
| POWER CIRCUIT BREAKERS 138KV, SF6, 1200 AMP | 4 | ea | \$80,000.00 | \$320,000.00 | \$10,920.00 | \$43,680.00 | \$363,680.00 |
| SWITCH, GOAB, VERTICAL BREAK, 230KV, 1200 AMP | 20 | ea | \$16,500.00 | \$330,000.00 | \$3,120.00 | \$62,400.00 | \$392,400.00 |
| SWITCH, GOAB, VERTICAL BREAK, 138KV, 1200 AMP | 4 | ea | \$12,500.00 | \$50,000.00 | \$3,120.00 | \$12,480.00 | \$62,480.00 |
| SWITCH, GOAB, V-BREAK, 230KV, 1200 AMP, LIVE_BREAK WITH MOTOR OPERATOR | 1 | ea | \$20,500.00 | \$20,500.00 | \$4,210.00 | \$4,210.00 | \$24,710.00 |
| TOTALS | | | | | \$4,080,500.00 | \$662,880.00 | \$4,743,380.00 |

230KV Upgrade Cost Estimate

4/3/01

STRUCTURES

| Item | Quantity | Unit | Material Cost | Mat Cost Per Unit | Installation Cost | Inst Cost Per Unit | Total Cost |
|---------------------------------------|----------|------|---------------|-------------------|-------------------|--------------------|--------------|
| 230KV DEAD END STRUCTURE (SINGLE BAY) | 5 | ea | \$12,860.00 | \$64,800.00 | \$12,868.00 | \$64,340.00 | \$129,140.00 |
| 230KV SWITCH STAND | 21 | ea | \$3,055.00 | \$64,155.00 | \$4,130.00 | \$86,730.00 | \$150,885.00 |
| 230KV THREE PHASE BUS SUPPORT | 21 | ea | \$2,130.00 | \$44,730.00 | \$4,112.00 | \$86,352.00 | \$131,082.00 |
| 230KV SINGLE PHASE BUS SUPPORT | 63 | ea | \$1,590.00 | \$100,170.00 | \$2,310.00 | \$145,530.00 | \$245,700.00 |
| 138KV DEAD END STRUCTURE (SINGLE BAY) | 2 | ea | \$9,970.00 | \$19,940.00 | \$9,360.00 | \$18,720.00 | \$38,660.00 |
| 138KV SWITCH STAND | 4 | ea | \$1,765.00 | \$7,060.00 | \$3,410.00 | \$13,640.00 | \$20,700.00 |
| 138KV THREE PHASE BUS SUPPORT | 4 | ea | \$1,635.00 | \$6,540.00 | \$3,400.00 | \$13,600.00 | \$20,140.00 |
| 138KV SINGLE PHASE BUS SUPPORT | 12 | ea | \$1,590.00 | \$19,080.00 | \$2,310.00 | \$27,720.00 | \$46,800.00 |
| TOTALS | | | | \$307,395.00 | | \$456,632.00 | \$783,107.00 |

230KV Upgrade Cost Estimate

4/3/01

FOUNDATION

| Item | Quantity | Unit | Material Cost | Mat Cost Per Unit | Installation Cost | Inst Cost Per Unit | Total Cost |
|--|----------|------|---------------|-------------------|-------------------|--------------------|----------------|
| FOUNDATION FOR TRANSFORMER, OIL CONTAINMENT | 5 | ea | \$78,700.00 | \$393,500.00 | \$72,450.00 | \$362,250.00 | \$755,750.00 |
| FOUNDATION FOR BREAKER | 14 | ea | \$1,735.00 | \$24,290.00 | \$2,150.00 | \$30,100.00 | \$54,390.00 |
| FOUNDATION FOR BUS SUPPORT, SWITCH, ETC | 175 | ea | \$1,919.00 | \$335,825.00 | \$2,310.00 | \$404,250.00 | \$740,075.00 |
| FOUNDATION FOR DEAD END STRUCTURE | 9 | ea | \$2,953.00 | \$26,577.00 | \$2,090.00 | \$18,810.00 | \$45,387.00 |
| TOTALS | | | | \$780,192.00 | | \$815,410.00 | \$1,595,602.00 |

230KV Upgrade Cost Estimate

4/3/01

| GROUNDING Item | Quantity | Unit | Material Cost | Mat Cost Per Unit | Installation Cost | Inst Cost Per Unit | Total Cost |
|----------------------------------|-----------------|-------------|----------------------|--------------------------|--------------------------|---------------------------|---------------------|
| CONDUCTOR, GROUND | 5000 | lf | \$1.00 | \$5,000.00 | \$12.00 | \$60,000.00 | \$65,000.00 |
| CONDUCTOR, FLEXIBLE COPPER BRAID | 28 | ea | \$65.00 | \$1,820.00 | \$75.00 | \$2,100.00 | \$3,920.00 |
| GROUND RODS | 200 | ea | \$25.00 | \$5,000.00 | \$500.00 | \$100,000.00 | \$105,000.00 |
| GROUND CLAMP, BRONZE | 200 | ea | \$30.00 | \$6,000.00 | \$35.00 | \$7,000.00 | \$13,000.00 |
| GROUNDING PLATFORM | 50 | ea | \$275.00 | \$13,750.00 | \$560.00 | \$28,000.00 | \$41,750.00 |
| TOTALS | | | | | \$31,570.00 | \$197,100.00 | \$228,670.00 |

Eklutna Project Transmission Line Replacement

This is a request for replacing the existing Eklutna Hydroelectric power plant transmission line, which is part of a critical Railbelt transmission network and directly serves Municipal Light & Power (ML&P), Chugach Electric Association (CEA) and Matanuska Electric Association (MEA).

It is a 28-mile line that was constructed in the 1950's as part of the Eklutna Hydroelectric Project. The transmission line follows an easement to the West of the Glenn Highway and the Old Glenn Highway, which runs from Anchorage to Palmer. The line directly ties generation sources from Anchorage to the Eklutna Hydroelectric Plant. It also serves as the alternate connection that links ML&P to CEA's transmission system and provides electrical energy to a significant portion of MEA's customers that are connected to substations off the line.

Recently, detailed inspections of the Eklutna Transmission line, brought about by repairs that were made to sections of the line lost in last year's avalanche, show that most of the line is aged and in bad condition, and will require significant refurbishment.

Currently, the owners (ML&P, CEA & MEA) are reviewing replacement and refurbishment options of the Eklutna system. For example: new design and replacement costs for just the oldest section of the line, which extends from the Eklutna plant to the first MEA substation in Eagle River (DOW), are estimated at \$6,000,000.

In addition, the Eklutna transmission line crosses the Kink River on the old, unused bridge. In the past, this bridge has been slated for demolition since it only serves foot traffic and is in disrepair. A new river crossing is necessary in order to refurbish or replace the existing transmission line and enable demolition of the old bridge.

The requirements of this project would include a new double-circuit, 230 kV insulation line design that will replace the existing wood structures with more aesthetic frameworks. It will be more considerate of avalanche problems and provide better seismic resistance. It will have the capability of transferring twice as much power, provide more redundancy and more reliability to both Anchorage and Palmer.

The new line design will extend an additional 10-miles and connect to the Southern portion of the Anchorage - Fairbanks Interline. This will increase the reliability of MEA's current system by providing redundant circuitry and reliability.

The investment would provide significant and needy improvements to the Anchorage area and would benefit residents for 50-years or more.

The cost to replace the entire Eklutna transmission line, to include a new river crossing, and redundancy to both ML&P and CEA's system, is estimated at \$25,000,000.

Repairs to the existing equipment are already being scheduled in order to retain the system's integrity. Therefore, it is of the essence that decisions are made on whether to repair or refurbish the existing transmission line.

- Construction could start as early as 2002
- Estimated total cost of the replacement project:
 - Design - \$3,750,000
 - Construction - \$21,250,000

Juneau/Hoonah Regional Transmission Intertie

Current Situation: There is currently no transmission interconnection in Southeastern Alaska. However, numerous studies have indicated that it is technically and economically feasible to interconnect communities from Metlakatla to Skagway with a submarine system that could provide the backbone for power sharing and consequential economic development throughout the region. Congress has authorized \$384 million for the intertie but appropriations will depend on future budget priorities and a 20 percent funding match from the local sponsor. One of the most feasible links in the intertie is the segment that would link Juneau to Admiralty Island. The line segment is part of the overall Juneau Area Power Supply System which is a \$61 million plan to provide a long term, reliable and, to the extent possible, renewable energy supply for Juneau and the surrounding area of Southeast Alaska. With this line Alaska Electric Light & Power (AEL&P) would provide power to the Green's Creek Mine and to the City of Hoonah. The City of Hoonah has adopted a resolution in support of the line. The Hoonah segment would help reduce their dependence on Power Cost Equalization (PCE) as the community would be able to receive power from the Juneau load center. Development of the line would hasten the development of the Lake Dorothy Hydropower project that is located in close proximity to the Snettisham Hydropower project and Transmission line. The line would be the first link in the Southeast Intertie system.

Project Description: The line would be a 69 kva land and submarine cable that would go from the Douglas Bridge substation to North Douglas Island (presently under construction), thence to Hawk Inlet on Admiralty Island, and finally to Greens Creek and Hoonah.

Cost of the System: The Total cost of the 54-mile project including associated substation upgrades and mitigation measures is estimated to be \$31 million.

Benefits: The transmission line would allow both the Greens Creek Mine and the City of Hoonah, now both heavily dependent on diesel generation, to access much less expensive power from the Juneau load center. The additional load would confirm the justification for the development of the Lake Dorothy Hydropower project that would then provide for the growing demand in the Juneau area. The line would eventually be extended beyond Hoonah to serve Tenakee, Angoon, and Kake. The line will also serve as a key link in the overall Southeastern intertie system. In addition to the economic benefits, the environmental quality of Juneau, Hoonah, and the Admiralty Island area will be enhanced from the annual reduction of nitrogen oxides, sulfur dioxide, and particulate matter that is vented to the air from the diesel generators.

Use of Funds: Funds provided under HB 175 would be used for engineering and environmental assessments and ongoing project construction.

CITY OF CORDOVA

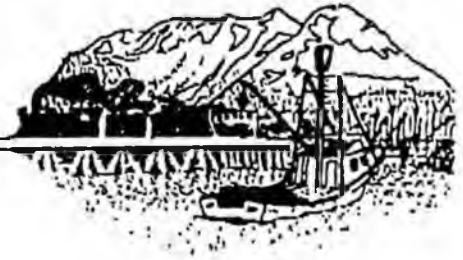

April 11, 2002

Representative Ken Lancaster
State Capitol, Room 204
Juneau, AK 99801-1182

Dear Representative Lancaster:

Cordova, like the State of Alaska, is a community in transition. In the wake of our declining timber and fishing industries, the future of our community is unclear. The very sustainability of our native and rural lifestyle is at stake, as evidenced by:

- A 9.4% decline in school enrollments over the last 5 years - mostly in grade school students, a frightening trend
- A decline from 591 to 534 business licenses issued in the last 3 years
- Almost \$90,000.00 in delinquent utility accounts sent to collections last year
- An increase in Property Tax foreclosure notices from 51 to 68 over the last 3 years

These are not devastating statistics, and Cordova won't dry up and blow away tomorrow. The trends for Cordova, however, are unsettling and the community is worried. A \$5,000,000 State grant for Power Creek will keep power costs from rising and help buffer these trends. A \$10,000,000 grant could very well reverse them.

In the midst of Cordova's struggle to stabilize our fishing economy and our culture, the Power Creek Hydroelectric Project has been one bright star of hope. The economic benefits of the project will not be fully realized until spring runoff and rising electrical loads decrease fuel use and increase revenues. The project has already provided the community an unforeseen benefit that is, in my opinion, equally important. The entire community of Cordova has united in support of the project. Power Creek and declining fisheries have stirred Cordova to action.

At a time when there is reason for discouragement, and a bleak prospect for economic diversity or growth statewide, Cordova is excited about our future prospects. Young, energetic citizens are running for city offices and filling seats on volunteer boards and commissions. Citizens are newly willing to allow, embrace, and even encourage creativity and innovative change. Town meetings, action committees, and a newly kindled resolve stir the streets of Cordova. A vote to grant State funding to the Power Creek Project is a vote of confidence for the hard-working people of Cordova, and may be just the catalyst this community needs to build a vital coastal economy that can serve as a model for the rest of the struggling coastal communities in the State. Let's be honest; if Cordova, with a reputation for internal conflict, can prove successful in this challenging economic climate, the entire state can be proud and encouraged by it.

Cordova, like many rural Alaskan communities, has strong economic and trade ties to Anchorage and rail belt communities. If Anchorage is the hub of the wheel of progress, then the rural communities are spokes. Cordova's success is, in small measure, the state's success. A vote for Power Creek grant funding is a vote for Cordova's future, and a vote for Alaska's future.

Sincerely,

Ed Zejke
City Manager

EZ:lk

Cc: City Council

CITY OF CORDOVA



April 11, 2002

Representative Bill Williams, Co-chair
 Representative Eldon Muldar, Co-chair
 Committee Members
 House Finance Committee
 State Capitol
 Juneau, AK 99801-1182

RE: HB 175

Dear Representative:

The City of Cordova is asking for our support of HB 175, which contains funding of debt reduction for the Cordova Electric Cooperative (CEC) for the Power Creek hydroelectric project in our community.

The high cost of electric power is the single greatest obstacle to the further development and diversification of the Cordova economy. Cordova is a single industry town. Harvesting and processing of fish dominate our economy, and most businesses depend on the success of our fishermen and processors to sustain them throughout the year. With the nature of fish markets shifting towards a value added product and more demand for custom sized portions, the cost of power directly affects our ability to satisfy our customers needs locally.

CEC is the sole provider of electricity to the City of Cordova and outlying users. As depicted below, the CEC service area has some of the highest electrical costs of any municipality in the southern Prince William Sound region.

1999 average annual energy rates (cents/kWh)

| Region/Community | Utility | Residential | Commercial | Industrial | Other | Total |
|-------------------|------------|-------------|-------------|---------------|-------------|---------------|
| Anchorage | CEA | 9.7 | 7.6 | 6.4 | 8.7 | 8.2 |
| Cordova | CEC | 23.9 | 19.9 | 14.6 | 19.7 | 20.5 |
| Homer/Seldovia | HEA | 11.5 | 9.8 | 4.4 | 8.8 | 9.5 |
| Kodiak/Port Lions | KDEA | 16.3 | 15.4 | 14.6 | 15.2 | 15.6 |
| Seward | SES | 12.3 | 13.9 | 10.1 | 11.5 | 12.7 |
| Valdez | CVEA | 15.7 | 13.3 | Not Available | 13.9 | Not Available |

Source: Department of Energy

Rep. Bill Williams
April 11, 2002
Page 2

With Power Creek Hydroelectric Project coming on-line, savings equaling the cost of almost one million gallons of fuel would be realized annually through reduced diesel fuel purchases. Without state assistance, those fuel savings would be offset by interest payments on the debt service of nearly \$900,000 per year. This amount is extraordinary considering that only 1,567 metered customers share the burden of these expenses. Without State funding, it is apparent that a rate increase will be required in order to ensure financial stability for the Cooperative. This would have a critical impact on the community business environment and contribute to a cost-pricing pass through in business services that would further increase the high cost of living in Cordova.

With the utilization of a renewable energy source through the Power Creek Hydroelectric Project, Cordova will be able to displace approximately 75% of the diesel fuel it now uses, equating to a significant reduction in the pollutants in our air shed. The resulting reduced annual emissions are approximately 250 tons in nitrogen oxide, 1.25 tons of sulfur dioxide and 25 tons of particulates.

In conclusion, this requested assistance from the State of Alaska would directly stimulate Cordova's economy through stabilization in electric power rates. This in turn would lower the cost-of-living, improve operating conditions for businesses across the economic spectrum and increase job opportunities. This assistance would also offer benefits in cost savings from the reduced need for diesel fuels, which are subject to unpredictable price fluctuations, and result in cleaner air.

Thank you for your encouragement of our community through your support of HB 175. Please contact me if you need any further information regarding our energy needs.

Sincerely,

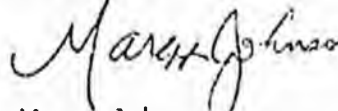

Margy Johnson
Mayor, City of Cordova



Alaska State Legislature

Please enter into the record my testimony to the House Finance

Committee on HB 175/APPROP: POWER PROJECTS committee name
bill # / subject Date, April 11, 2002

I would like to go on record as being **OPPOSED** to **HB 175**, which appears to **GIVE PUBLIC** money to **PRIVATE** utilities. This seems to be nothing more than "**CORPORATE WELFARE** at taxpayers' expense".

This **PRIVATE** industry may need periodic financial assistance to meet **THEIR** needs, but this should **NOT** be done with **OUR** tax dollars. There are currently many banks and various other lending institutions throughout Alaska and the world available to finance any sound business plan. This leads me to wonder, "Why is the State using our tax dollars to compete with these private businesses"?

Since the mid 1970's the Legislature has given away **BILLIONS** to those with a "good idea". Pt. Mac Dairy Farms, Delta Barley Farms, and the Healy Project are just a few that come to mind. Now that we are facing a **BILLION** dollar budget deficit, how can you continue to justify making these expenditures?

Throughout Alaska, voters whom the Legislature is empowered to represent, are being told about closing of state parks, layoff of troopers, snowplow drivers, educators, health inspectors, etc., while **GRANTS** for these multi-million dollar projects are still being considered. Do we really have a budget deficit or not? If we have a deficit, then why are you continuing to **GIVE AWAY** millions of our dollars?

In my opinion **HB 175** is nothing more than another "give a way" program designed to further deplete the budget reserve account, and a prime example of non-essential government spending. No Alaskan **VOTER** will ever seriously consider new taxes until all public funds given to private businesses, individuals, and special interest groups has been completely eliminated.

Our public money would be better spent funding essential government services such as education, roads, public health & safety.

Please vote **NO** on **HB 175**. Thank you.

Signed: Mike McBride
Testifier
Self
Representing (optional)
PO Box 6; Kenai, Alaska; 99611
Address
776-5444
Phone number

HB

175

SFIN

FILE

HB 175

was referred to the
Senate Finance
Committee

No hearing was held
on this bill

HB

177

HFIN

FILE

HOUSE COMMITTEE REPORT

(11)

Date Referred to Committee: April 2, 2001

FURTHER REFERRALS:

Date of Committee Action: 4/9/01

The FINANCE Committee considered:

HB 177

HOUSE BILL NO. 177

CAMPAIGN FINANCE: CONTRIB/DISCLOS/GROUPS

"An Act placing certain special interest organizations within the definition of 'group' for purposes of Alaska's campaign finance statutes; providing a contingent amendment to take effect in case subjecting these organizations to all of the statutory requirements pertaining to groups is held by a court to be unconstitutional; requiring certain organizations to disclose contributions made to them and expenditures made by them; requiring disclosure of the true source of campaign contributions; and providing for an effective date."

Recommends it be replaced with CS HB 177 (STA) [] Same Title [] New Title
 For Senate Bills with new title: [] Technical Title [] New Title: HCR _____

- [] attach amendments
- [] add new referral to _____ Committee
- [] Letter of Intent _____ Committee

List of Abbrev. For Depts:
 ADM
 CED
 COR
 CRT
 EED
 DFC
 DFG
 GOV
 HSS
 LAA
 LAW
 IWF
 MVA
 DNR
 DPS
 REV
 DOT
 UA

| <u>NEW FISCAL NOTES</u> | | | | |
|------------------------------------|------------------|--------|--------|------|
| *For Chief Clerk's Office Use Only | | | | |
| FN# | List by Dept(s): | Fiscal | Indet. | Zero |
| | | | | |
| | | | | |
| | | | | |
| | | | | |
| | | | | |
| | | | | |
| | | | | |
| | | | | |
| | | | | |
| | | | | |
| | | | | |
| | | | | |
| | | | | |
| | | | | |
| | | | | |
| | | | | |
| | | | | |
| | | | | |
| | | | | |
| | | | | |
| | | | | |
| | | | | |

| <u>PREVIOUS FISCAL NOTES</u> | | | | |
|------------------------------|------|--------|--------|------|
| List by Dept(s): | FN # | Fiscal | Indet. | Zero |
| | | | | |
| | | | | |
| | | | | |
| | | | | |
| DOA | 1 | ✓ | | |
| | | | | |
| | | | | |
| | | | | |
| | | | | |
| | | | | |
| | | | | |
| | | | | |
| | | | | |
| | | | | |
| | | | | |
| | | | | |
| | | | | |
| | | | | |
| | | | | |
| | | | | |
| | | | | |
| | | | | |
| | | | | |
| | | | | |

| <u>Signing with recommendation:</u> | Printed Last Name | DP | DNP | NR | AM |
|-------------------------------------|-------------------|----|-----|----|----|
| <i>[Signature]</i> | Bunde | ✓ | | | |
| <i>[Signature]</i> | Whitaker | ✓ | | | |
| <i>[Signature]</i> | Harris | ✓ | | | |
| <i>[Signature]</i> | CRIST | | | ✓ | |
| <i>[Signature]</i> | DAVIS | | | ✓ | |
| <i>[Signature]</i> | MOSES | | | ✓ | |
| <i>[Signature]</i> | LANCASTER | ✓ | | | |
| <i>[Signature]</i> | HUSON | | | ✓ | |
| Chair: _____ | | | | | |
| Chair: <i>[Signature]</i> | Williams | ✓ | | | |

FISCAL NOTE

STATE OF ALASKA
2001 LEGISLATIVE SESSION

Fiscal Note Number: 1
 Bill Version: CSHB 177(STA)
 (H) Publish Date: 3/22/01

Revision Date/Time (Note if correction): _____ Dept. Affected: Administration
 Title: An act placing certain special interest BRU: Alaska Public Offices Commission
groups within the definition of "group..." Component: _____
 Sponsor: House Rules Committee
 Requester: House State Affairs Committee Component Number: 70

Expenditures/Revenues (Thousands of Dollars)

Note: Amounts do not include inflation unless otherwise noted below.

| OPERATING EXPENDITURES | FY 2002 | FY 2003 | FY 2004 | FY 2005 | FY 2006 | FY 2007 |
|------------------------|-------------|-------------|-------------|-------------|-------------|-------------|
| Personal Services | 42.5 | 0.0 | 0.0 | 0.0 | 0.0 | 0.0 |
| Travel | 4.1 | 2.5 | 2.5 | 2.5 | 2.5 | 2.5 |
| Contractual | 23.2 | 23.2 | 23.2 | 23.2 | 23.2 | 23.2 |
| Supplies | 1.0 | 1.0 | 1.0 | 1.0 | 1.0 | 1.0 |
| Equipment | | | | | | |
| Land & Structures | | | | | | |
| Grants & Claims | | | | | | |
| Miscellaneous | | | | | | |
| TOTAL OPERATING | 70.8 | 26.7 | 26.7 | 26.7 | 26.7 | 26.7 |

| | | | | | | |
|-----------------------------|--|--|--|--|--|--|
| CAPITAL EXPENDITURES | | | | | | |
|-----------------------------|--|--|--|--|--|--|

| | | | | | | |
|-------------------------------|--|--|--|--|--|--|
| CHANGE IN REVENUES () | | | | | | |
|-------------------------------|--|--|--|--|--|--|

FUND SOURCE (Thousands of Dollars)

| | | | | | | |
|--------------------------|-------------|-------------|-------------|-------------|-------------|-------------|
| 1002 Federal Receipts | | | | | | |
| 1003 GF Match | | | | | | |
| 1004 GF | 70.8 | 26.7 | 26.7 | 26.7 | 26.7 | 26.7 |
| 1005 GF/Program Receipts | | | | | | |
| 1037 GF/Mental Health | | | | | | |
| Other (Specify Type) | | | | | | |
| TOTAL | 70.8 | 26.7 | 26.7 | 26.7 | 26.7 | 26.7 |

Estimate of any current year (FY2001) cost: 0.0

Check this box (X) if funding for this bill is included in the Governor's FY 2002 budget proposal:

POSITIONS

| | | | | | | |
|-----------|---|---|---|---|---|---|
| Full-time | 0 | 0 | 0 | 0 | 0 | 0 |
| Part-time | 0 | 0 | 0 | 0 | 0 | 0 |
| Temporary | 1 | 0 | 0 | 0 | 0 | 0 |

ANALYSIS: (Attach a separate page if necessary)

See Attached

Prepared by: Brooke Miles Phone 907-276-4176
 Division: Alaska Public Offices Commission Date/Time 3/21/01 1:31PM
 Approved by: Jim Duncan, Commissioner Date 3/21/01
 Agency: Department of Administration

For distribution information, call the Governor's Legislative Office

COMMITTEE COPY

This is staff's estimate of the fiscal impact of HB 177. The Commission will not have an opportunity to review the legislation and staff's recommendation for a fiscal note until their next meeting on March 29th and 30th, 2001.

SB 177 amends the financial disclosure law and will result in additional costs to the Commission.

This bill will permit a proliferation of non-group entities described by the Alaska Supreme Court in its decision in State of Alaska v. Alaska Civil Liberties Union [ACLU]. Current regulations have narrowly interpreted this area of law and set forth a process through which non-profit corporations may qualify to participate in election campaign activities. HB 177, however, does not prescribe a procedure for the entities to "qualify" or to certify that they, in fact, meet the 3-part test set out by the Alaska Supreme Court in ACLU and referenced in this measure.

In the first year only, additional personal service funding is required to pay for a temporary regulations specialist to promulgate regulations implementing the changes.

Travel funding will enable staff to educate persons involved with non-group entities about the campaign disclosure law.

The Commission's staff anticipates that this legislation will result in an increase of public inquiries and complaints. Contractual funding is to pay for revisions of the written materials and postage and educational materials to cover an anticipated increase in investigation costs.

Supply funding is to pay for paper, printing and postage.

Headquarters:
217 2nd Street, Suite 201
Juneau, Alaska 99801
(907) 586-2323 FAX 463-5515
ascjuno@ptialaska.net



Regional Office:
P.O. Box 91896
Anchorage, Alaska 99509
(907) 278-2722 FAX 278-6643
ascanch@ptialaska.net

March 28, 2001

Representative Pete Kott
Alaska State Legislature
Juneau, Alaska

Re: HB 177 - Full Disclosure of Campaign Finances

Dear Representative Kott:

The Alaska State Chamber of Commerce is in support of HB 177, requiring certain special interest organizations to disclose contributions received and expenditures made for campaigns, and to disclose the true source of the campaign contributions.

The purpose behind the disclosure requirements of Alaska's Campaign Finance laws is to provide the public with full knowledge of which citizens or groups of citizens are promoting or trying to defeat an issue that is up for a vote of the public. A loophole in existing law has made it possible for a very select group of people to spend unlimited amounts of money, collected from donors who are allowed to remain anonymous, for the purpose of swaying voters to support their ideology.

Alaska's voters deserve to know who the contributors are and in which states the individuals reside who are trying to persuade Alaskans to support their cause. This is required of all other groups and is no more than the public has the right to expect. If a cause is worthy of public support, there is no reason its promoters should need to hide behind their funding sources.

We urge the Legislature to correct this inequity and make full and complete disclosure a priority in every election campaign.

Sincerely,

A handwritten signature in cursive script that reads "Pamela LaBolle".

Pamela La Bolle
President

FISCAL NOTE

STATE OF ALASKA
2001 LEGISLATIVE SESSION

Fiscal Note Number: 1
 Bill Version: CSHB 177(STA)
 (H) Publish Date: 3/22/01

Revision Date/Time (Note if correction): _____ Dept. Affected: Administration
 Title: An act placing certain special interest BRU: Alaska Public Offices Commission
groups within the definition of "group..." Component: _____
 Sponsor: House Rules Committee
 Requester: House State Affairs Committee Component Number: 70

Expenditures/Revenues (Thousands of Dollars)

Note: Amounts do not include inflation unless otherwise noted below.

| OPERATING EXPENDITURES | FY 2002 | FY 2003 | FY 2004 | FY 2005 | FY 2006 | FY 2007 |
|------------------------|-------------|-------------|-------------|-------------|-------------|-------------|
| Personal Services | 42.5 | 0.0 | 0.0 | 0.0 | 0.0 | 0.0 |
| Travel | 4.1 | 2.5 | 2.5 | 2.5 | 2.5 | 2.5 |
| Contractual | 23.2 | 23.2 | 23.2 | 23.2 | 23.2 | 23.2 |
| Supplies | 1.0 | 1.0 | 1.0 | 1.0 | 1.0 | 1.0 |
| Equipment | | | | | | |
| Land & Structures | | | | | | |
| Grants & Claims | | | | | | |
| Miscellaneous | | | | | | |
| TOTAL OPERATING | 70.8 | 26.7 | 26.7 | 26.7 | 26.7 | 26.7 |

| | | | | | | |
|-----------------------------|--|--|--|--|--|--|
| CAPITAL EXPENDITURES | | | | | | |
|-----------------------------|--|--|--|--|--|--|

| | | | | | | |
|-------------------------------|--|--|--|--|--|--|
| CHANGE IN REVENUES () | | | | | | |
|-------------------------------|--|--|--|--|--|--|

FUND SOURCE (Thousands of Dollars)

| | | | | | | |
|--------------------------|-------------|-------------|-------------|-------------|-------------|-------------|
| 1002 Federal Receipts | | | | | | |
| 1003 GF Match | | | | | | |
| 1004 GF | 70.8 | 26.7 | 26.7 | 26.7 | 26.7 | 26.7 |
| 1005 GF/Program Receipts | | | | | | |
| 1037 GF/Mental Health | | | | | | |
| Other (Specify Type) | | | | | | |
| TOTAL | 70.8 | 26.7 | 26.7 | 26.7 | 26.7 | 26.7 |

Estimate of any current year (FY2001) cost: 0.0

Check this box (X) if funding for this bill is included in the Governor's FY 2002 budget proposal:

POSITIONS

| | | | | | | |
|-----------|---|---|---|---|---|---|
| Full-time | 0 | 0 | 0 | 0 | 0 | 0 |
| Part-time | 0 | 0 | 0 | 0 | 0 | 0 |
| Temporary | 1 | 0 | 0 | 0 | 0 | 0 |

ANALYSIS: (Attach a separate page if necessary)

See Attached

Prepared by: Brooke Miles Phone 907-276-4176
 Division: Alaska Public Offices Commission Date/Time 3/21/01 1:31PM
 Approved by: Jim Duncan, Commissioner Date 3/21/01
 Agency: Department of Administration

For distribution information, call the Governor's Legislative Office

COMMITTEE COPY

This is staff's estimate of the fiscal impact of HB 177. The Commission will not have an opportunity to review the legislation and staff's recommendation for a fiscal note until their next meeting on March 29th and 30th, 2001.

SB 177 amends the financial disclosure law and will result in additional costs to the Commission.

This bill will permit a proliferation of non-group entities described by the Alaska Supreme Court in its decision in State of Alaska v. Alaska Civil Liberties Union [ACLU]. Current regulations have narrowly interpreted this area of law and set forth a process through which non-profit corporations may qualify to participate in election campaign activities. HB 177, however, does not prescribe a procedure for the entities to "qualify" or to certify that they, in fact, meet the 3-part test set out by the Alaska Supreme Court in ACLU and referenced in this measure.

In the first year only, additional personal service funding is required to pay for a temporary regulations specialist to promulgate regulations implementing the changes.

Travel funding will enable staff to educate persons involved with non-group entities about the campaign disclosure law.

The Commission's staff anticipates that this legislation will result in an increase of public inquiries and complaints. Contractual funding is to pay for revisions of the written materials and postage and educational materials to cover an anticipated increase in investigation costs.

Supply funding is to pay for paper, printing and postage.



Alaska State Legislature

HOUSE OF REPRESENTATIVES
Alaska State Capitol Juneau, Alaska 99801-1181

SPONSOR STATEMENT

COMMITTEE SUBSTITUTE FOR HOUSE BILL 177 (STA)

"An Act placing special interest organizations within the definition of 'group' for purposes of Alaska's campaign finance statutes; and requiring disclosure of the true source of campaign contributions."

In 1999, the Alaska Supreme Court in ACLU v. State upheld Alaska's ban on political contributions and independent expenditures by corporations and labor unions. But the court also held that entities must be allowed to make independent expenditures if "(1) they cannot participate in business activities, (2) they have no shareholders who have a claim on corporate earnings, and (3) they are independent from the influence of business corporations." The court also suggested that entities, which meet these three criteria, must be permitted to make political contributions.

The committee substitute for House Bill 177 clarifies that non-group entities that meet these three criteria may make contributions and independent expenditures. It also subjects them to the same rules--including contribution limits and reporting requirements--as other groups that participate in political campaigns.



Alaska State Legislature

HOUSE OF REPRESENTATIVES
Alaska State Capitol Juneau, Alaska 99801-1181

SECTIONAL ANALYSIS

COMMITTEE SUBSTITUTE FOR HOUSE BILL 177 (STA)

"An Act placing special interest organizations within the definition of 'group' for purposes of Alaska's campaign finance statutes; and requiring disclosure of the true source of campaign contributions."

Section 1: Adds a new section to uncodified law by giving this bill a short title: Full Disclosure of Campaign Finance Act.

Section 2: Amends AS 15.13.040(b). Contributions, expenditures, and supplying of services to be reported. This section requires groups to disclose the contributor of contributions in excess of \$100. Contributor is defined as the true source of the contribution. The true source of income is the original source of the contribution.

Section 3: Amends AS 15.13.400(5). Definitions. The definition of group is amended to include special interest organizations that fall within the mandatory exception to corporate contribution bans identified in *Federal Election Commission v. Massachusetts Citizens for Life*, 479 U.S. 238 (1986), by incorporating, into statute, the three part test cited by the Alaska Supreme Court in *State v. Alaska Civil Liberties Union*, 978 P.2d at 612.

HB

177

SFIN

FILE

HB 177

was referred to the
Senate Finance
Committee

No hearing was held
on this bill

Bill was WAIVED from Committee



OFFICIAL BUSINESS

Alaska State Legislature
Senate
Office of the Secretary

STATE CAPITOL, ROOM 213
JUNEAU, ALASKA 99801-1182
(907) 465-3701
FAX: 465-2832
EMAIL: senate_secretary@legis.state.ak.us

FOR YOUR IMMEDIATE ATTENTION

DATE: May 2, 2001
TO: Finance Committee
(Mindy/Cadie - Room 520)
FROM: Office of the Senate Secretary
SUBJ: Waived Bill(s)

The Chair of the Committee noted above has waived referral on the following bill(s):

RETRIEVE

CS FOR HOUSE BILL NO. 177(STA)

"An Act placing certain special interest organizations within the definition of 'group' for purposes of Alaska's campaign finance statutes; and requiring disclosure of the true source of campaign contributions."

Please give the bill file(s) to the page for forwarding to the next Committee of referral.

Thank you.