

LEG. FINANCE - BILLS 1977 - 1978 679
HB 185, HB 186, HB 189



RECORDS CERTIFICATION

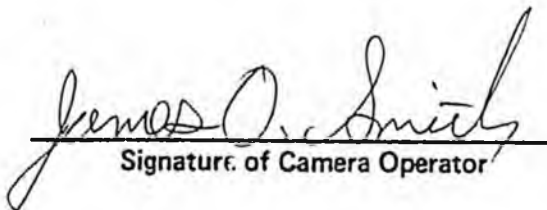

I, the undersigned, an employee of the State of Alaska, do hereby certify that the microfilm images on this microform are accurate reproductions of the original records of the State of Alaska as accumulated during the regular course of business, and that it is the established policy and practice of this State to microfilm its records and to dispose of the original records after microfilm reproductions have been made.

Signature of Camera Operator

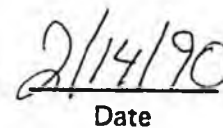
Date

(11)

COMMITTEE REPORT

HOUSE

FURTHER:

March 10, 1979

Date: 3-14-79

Mr. Speaker:

The Committee on FINANCE has had HB 185

"An Act authorizing state aid to municipalities for the construction and development of cultural facilities."

under consideration and (a majority of the committee) (the committee) reports it back with the following recommendations:

- do pass do not pass
- do pass with attached amendments(s)
- replace with CS for _____ same title
- new title
- and recommends _____
- AND attaches a "Letter of Intent" ~~FISCAL~~ Fiscal Note
- reports it back without recommendation
- referred to the _____ Committee

**MEMBERS SIGNING
DO PASS**

Ferguson

McKinney

Smith

Harmon

Matson

Wicks

**MEMBERS HAVING
OTHER RECOMMENDATIONS:**

Rogers NO REC

Meekins

CHAIRMAN

100-205

THE LEGISLATURE OF THE STATE OF ALASKA
ELEVENTH LEGISLATURE

FISCAL NOTE

I. REQUEST
 Bill/Resolution No. HR 135
 Title "An Act authorizing state aid to municipalities for the construction and development of cultural facilities." Date 3-9-79

II. FISCAL DETAIL
 Agency Affected Commerce and Economic Development
 Program Category Affected Development
 Budget Request Unit(s) Affected _____

EXPENDITURES (Thousands of Dollars)

| | FY 79 | FY 80 | FY 81 | FY 82 | FY 83 | FY 84 |
|--------------------------|-------|-------|-------|-------|-------|-------|
| 100 PERSONAL SERVICES | | 47.0 | 49.8 | 52.8 | | |
| 200 TRAVEL | | 12.5 | 13.3 | 14.1 | | |
| 300 CONTRACTUAL | | 8.0 | 7.8 | 8.0 | | |
| 400 COMMODITIES | | .4 | .4 | .4 | | |
| 500 EQUIPMENT | | 1.5 | .3 | .3 | | |
| 600 LAND & STRUCTURES | | | | | | |
| 700 GRANTS, CLAIMS, ETC. | | | | | | |
| TOTAL | | 69.4 | 71.6 | 75.6 | | |

FUNDING (Thousands of Dollars)

| | | | | | | |
|-----------------|--|------|------|------|--|--|
| GENERAL FUND | | 69.4 | 71.6 | 75.6 | | |
| FEDERAL FUNDS | | | | | | |
| OTHER (Specify) | | | | | | |
| | | | | | | |

POSITIONS

| | | | | | | |
|-----------|--|-----|-----|-----|--|--|
| FULL TIME | | 1.5 | 1.5 | 1.5 | | |
| PART TIME | | | | | | |
| TEMPORARY | | | | | | |

III. ANALYSIS (See Fiscal Note Preparation Instructions, Section III)

Equipment and advertising - larger expenditures required the first year.
 This Fiscal Note assumes no construction of cultural facilities.

IV. DATE March 9, 1979 PREPARED BY Bert Wagon, Deputy Commissioner
 AGENCY Commerce and Economic Development
 Original: Legislative Finance PHONE 465-2500
 cc: Budget and Management
 Prime Sponsor (First Legislator Named)

Advisory Commission

5 Members - no compensation

First year - Travel - 4 meetings @ \$250 per meeting\$5,000
 three days per diem @ \$165 per meeting..... 3,300

Second year - Travel - 3 meetings - travel & per diem @ \$430 per meeting.... 6,450

Third year - Travel - 2 meetings - travel & per diem @ \$460 per meeting..... 4,600

Assumptions:

1. Personnel Services

One Professional person, a Capital Improvement Project Coordinator (range 20) will be required. This position will:

- a) establish an application process
- b) work closely with each community which applies for funds to construct cultural facilities
- c) administer the grant program
- d) oversee the engineering and architectural work and;
- e) prepare the financial package to go to bid.

(Salary \$2,532 per month, plus benefits of \$684 per month.)

In addition, one clerical person working half-time will be required. Clerk Typist III (range 8) for correspondence, filing, etc.

(Salary \$554 per month plus benefits of \$150 per month.)

2. Travel requirements are estimated at 12 trips @ \$350 per trip (per diem included in estimate). These trips will be required during the application process, to meet with the cultural coordinating committees over architectural designs and engineering estimates and during the early stages of construction.

3. Contractual

- A. Rent - 250 feet² @ \$1.25 per feet²/month\$3,700
- B. Telephone, communications..... 1,300
- C. Postage, etc..... 500
- D. Printing and advertising..... 1,000
- E. Professional fees and services..... 1,500

4. Commodities

Office supplies 400

5. Equipment

Desk, chair, file cabinet, calculator..... 1,500

After FY '80 - inflation estimated @ 6% per year.

Introduced: 2/13/79
Referred: Health, Education &
Social Services and Finance

BY DUNCAN, ANDERSON, BRANSON, BUCHHOLDT,
ELIASON, FREEMAN, MCKINNON, MILES, MILLER,
MUNSON, PARKER, SCHAEFFER, SMITH AND
GARDINER

1 IN THE HOUSE

2 HOUSE BILL NO. 185

3 IN THE LEGISLATURE OF THE STATE OF ALASKA

4 ELEVENTH LEGISLATURE - FIRST SESSION

5 A BILL

6 For an Act entitled: "An Act authorizing state aid to municipalities for the
7 construction and development of cultural facilities."

8 BE IT ENACTED BY THE LEGISLATURE OF THE STATE OF ALASKA:

9 * Section 1. AS 43.18 is amended by adding a new section to read:

10 ARTICLE 5. CULTURAL FACILITIES.

11 Sec. 43.18.500. CULTURAL FACILITY CONSTRUCTION AND DEVELOPMENT

12 GRANTS. (a) There is established within the Department of Commerce and
13 Economic Development a cultural facilities development fund for the pur-
14 pose of providing state assistance in the construction and development
15 of cultural facilities within those municipalities which actively pro-
16 vide support to the arts and humanities. Within the limits of direct
17 appropriations for the purpose or through the appropriation of the
18 proceeds of a general obligation bond issue, the department shall make
19 grants to municipalities for construction and development of cultural
20 facilities.

21 (b) A grant for only one project may be awarded to a municipality
22 under this section.

23 (c) Application for a grant shall be made in the form required by
24 the commissioner.

25 (d) No application for a grant may be considered for approval by
26 the commissioner and no funds paid by him under this section unless

27 (1) the project is endorsed by resolution of the governing
28 body of the sponsoring municipality on its own behalf or on behalf of
29 the officially recognized arts and humanities planning organization of

1 the municipality;

2 (2) the commissioner is satisfied that the sponsoring munic-
3 pality

4 (A) has the authority under AS 29.41 or AS 29.48 to
5 provide and maintain a cultural facility;

6 (B) is able to provide the local share of project con-
7 struction costs; and

8 (C) will be financially able to maintain and operate the
9 facility upon completion;

10 (3) the municipality provides plan designs and specifica-
11 tions, together with blueprints or schematics of detail sufficient to
12 enable the commissioner to verify estimates of construction costs; and

13 (4) the complete application has been submitted

14 (A) to the state assessor for his determination and
15 verification that the fair market value of any real property
16 claimed as a credit under (f)(4) of this section is accurate; and

17 (B) to the Advisory Commission on Cultural Facilities
18 (AS 44.33.400 - 44.33.410) for its review.

19 (e) The grant to a municipality shall be disbursed in accordance
20 with the terms of an agreement between the commissioner, on behalf of
21 the state, and the governing body of the municipality receiving the
22 grant. The agreement may include any provision agreed upon by the
23 parties, but shall include in substance the following provisions:

24 (1) the municipality shall secure, retain and protect title
25 to the site or location on which the facility is to be constructed or
26 developed; for purposes of this paragraph it is sufficient that title is
27 obtained in fee or by lease by the terms of which the municipality
28 enjoys exclusive use of the land and any improvements for the estimated
29 project life of the facility or the period of maturity of any state

1 general obligation bond a portion of the proceeds of which are used to
2 provide financial assistance for the construction or development of the
3 facility;

4 (2) the municipality agrees to provide the local contribution
5 to project cost required by (f) of this section, and to return to the
6 state any excess contribution by the state as required by (h) of this
7 section;

8 (3) the municipality agrees to proceed with and complete the
9 proposed project expeditiously in accordance with plans originally
10 submitted;

11 (4) the municipality will not materially alter or modify
12 plans for the facility or undertake construction in a manner which
13 materially departs from the approved design and plan for construction or
14 development of the facility without first securing the prior written
15 approval of the officially recognized arts and humanities planning
16 organization of the municipality;

17 (5) the municipality agrees to assume responsibility for the
18 maintenance and operation of the facility, directly or by delegation of
19 responsibility to an entity organized by ordinance of the municipality
20 or to a nonprofit corporation dedicated to the arts and recognized by
21 the municipality; the feasibility of the discharge of this obligation
22 shall be demonstrated to the satisfaction of the commissioner before the
23 payment of any state funds; and

24 (6) the parties agree that if property constructed or deve-
25 loped with financial assistance provided under this section is designed
26 or used for purposes other than for principal use as a cultural facil-
27 ity, the state may require the municipality to reimburse the state for
28 that portion of the market value of the property which the state's
29 investment in the property bears to the total of investment from all

1 sources made in the property.

2 (f) A municipality receiving a grant under this section shall
3 contribute to the total cost of the project. The amount of the munic-
4 ipality's contribution is determined by the application of the formula

5 (average per capita assessed valuation of the muni-
6 cipality/average per capita assessed valuation of
7 the state) x contribution percentage

8 to the estimated total project cost as determined by the commissioner at
9 the time of approval of a grant application. For purposes of this
10 subsection

11 (1) the contribution percentage for

12 (A) a municipality having a population of 5,000 or less
13 is 10 per cent;

14 (B) a municipality having a population of 5,001 to
15 10,000 is 20 per cent; and

16 (C) a municipality having a population of more than
17 10,000 is 30 per cent;

18 (2) if an application is submitted for a municipality for
19 which no average per capita assessed valuation has been determined, the
20 commissioner shall request the state assessor to compute the factor and
21 report it to him;

22 (3) the contribution of the municipality may not exceed a
23 rate equal to the contribution percentage established in (1) of this
24 subsection;

25 (4) there shall be allowed as a credit against the municipal-
26 ity's contribution computed under this subsection,

27 (A) for a project involving construction of a new faci-
28 lity, the fair market value of land acquired by the municipality as
29 the site or location for the facility;

1 (B) for a project involving development of an existing
2 structure or facility, the fair market value of the land and im-
3 provements which are acquired by the municipality and committed for
4 use as a cultural facility;

5 (5) the grant awarded by the state may not exceed the esti-
6 mated project cost verified by the commissioner under (d)(3) of this
7 section less the contribution by the municipality determined in accor-
8 dance with this subsection.

9 (g) If funds appropriated or provided by bond issue for grants
10 under this section are not adequate to satisfy amounts required by
11 approved grant applications, funds shall be allocated by the commis-
12 sioner on the basis of priority determined by the Advisory Commission on
13 Cultural Facilities.

14 (h) If, upon completion of the facility, it appears that actual
15 project costs varied substantially from estimated project costs deter-
16 mined by the commissioner under (d)(3) of this section and

17 (1) if the actual contribution of the state exceeds the per-
18 centage of project costs payable by the state determined under (f)(5) of
19 this section, the commissioner shall require the municipality to pay an
20 amount to the state sufficient to reduce the state contribution to the
21 percentage of state contribution required by (f)(5) of this section;

22 (2) if the actual project costs exceed estimates, the commis-
23 sioner may provide additional financial assistance to the municipality;
24 the additional state grant may not exceed an amount equal to the ratio
25 originally determined under (f)(5) of this section applied to the in-
26 cremental project costs.

27 (i) The commissioner shall provide an annual report to the legis-
28 lature with respect to grants made under this section.

29 (j) The commissioner may adopt regulations to carry out the pro-

1 visions of this section.

2 (k) In this section,

3 (1) "commissioner" means the commissioner of commerce and
4 economic development;

5 (2) "construction" means site preparation, erection of a
6 structure, and acquisition and installation of fixtures and necessary
7 fixed equipment, but does not include completion of feasibility studies,
8 site acquisition or facility design;

9 (3) "cultural facility" means a structure or complex the
10 principal purpose of which is to serve the visual and performing arts,
11 including but not limited to a theatre, concert hall or gallery, or to
12 serve as the repository of the historical or contemporary heritage of
13 the community and its people, and which also may be used for compatible
14 activities, including but not limited to, activities relating to educa-
15 tion, community meetings, tourism, and visitor information.

16 (4) "department" means the Department of Commerce and Eco-
17 nomic Development;

18 (5) "development" means the acquisition and preservation, re-
19 modeling or redevelopment of an existing structure or facility, together
20 with the acquisition and installation of fixtures and necessary fixed
21 equipment, for use as a cultural facility.

22 * Sec. 2. AS 44.19.930 is amended by adding a new paragraph to read:

23 (5) to recommend to the governor a list of persons for con-
24 sideration for appointment to the Advisory Commission on Cultural Faci-
25 lities, in accordance with AS 44.33.400.

26 * Sec. 3. AS 44.33 is amended by adding new sections to read:

27 ARTICLE 9. ADVISORY COMMISSION ON CULTURAL
28 FACILITIES.

29 Sec. 44.33.400. ADVISORY COMMISSION ON CULTURAL FACILITIES ESTAB-

1 LISHED. (a) There is in the Department of Commerce and Economic De-
2 velopment the Advisory Commission on Cultural Facilities.

3 (b) The commission consists of five members, appointed by the
4 governor from a list of candidates provided to him for that purpose by
5 the State Council on the Arts. The members of the commission are
6 appointed for overlapping three-year terms, with two of the members
7 first appointed serving three years, two of the members serving two
8 years, and one member serving a term of one year.

9 (c) The commission shall select a chairman and vice-chairman from
10 its membership.

11 Sec. 44.33.405. TRAVEL EXPENSES AND PER DIEM. Members of the
12 Advisory Commission on Cultural Facilities are not entitled to receive
13 compensation for their services, but they shall receive per diem and
14 travel expenses allowed by law for members of boards and commissions for
15 attendance at a maximum of four meetings per year.

16 Sec. 44.33.410. DUTIES. The Advisory Commission on Cultural
17 Facilities shall

18 (1) by regulation, establish criteria for ranking applica-
19 tions for grants to municipalities for the purpose of construction or
20 development of cultural facilities under AS 43.18.500; the regulations
21 shall provide for the assignment of priority among applications trans-
22 mitted by the commissioner, reserving for the highest priority those
23 applications for financial assistance involving the redevelopment or
24 rehabilitation of a structure qualifying as an historic property or a
25 building of historical value which is part of an historical district;
26 the criteria for ranking applications may include facility need and
27 suitability, public support for construction and maintenance of a facil-
28 ity, availability of land, management capacity, alternatives to comple-
29 tion of the facility proposed, and cost;

1 (2) by application of the criteria adopted under (1) of this
2 section, advise the commissioner regarding the approval of requests for
3 financial assistance in the construction of cultural facilities sub-
4 mitted in accordance with AS 43.18.500;

5 (3) at the request of a municipality, provide assistance in
6 the preparation of an assessment of needs and review proposals and plans
7 for construction or development of a cultural facility, for which finan-
8 cial assistance is requested under AS 43.18.500; and

9 (4) submit an annual report to the commissioner and the
10 legislature summarizing its activities and expenses.

11 * Sec. 4. AS 44.33.020 is amended by adding a new paragraph to read:

12 (22) administer the program of state assistance for the
13 construction and development of cultural facilities in accordance with
14 AS 43.18.500.

15 * Sec. 5. AS 29.48.030(14) is amended to read:

16 (14) libraries, visual or performing arts centers, or museums;
17
18
19
20
21
22
23
24
25
26
27
28
29

Introduced: 2/13/79
Referred: Health, Education &
Social Services and Finance

BY DUNCAN, ANDERSON, BRANSON, BUCHHOLDT,
ELIASON, FREEMAN, MCKINNON, MILES, MILLER,
MUNSON, PARKER, SCHAEFFER, SMITH AND
GARDINER

1 IN THE HOUSE

2 HOUSE BILL NO. 185

3 IN THE LEGISLATURE OF THE STATE OF ALASKA

4 ELEVENTH LEGISLATURE - FIRST SESSION

5 A BILL

6 For an Act entitled: "An Act authorizing state aid to municipalities for the
7 construction and development of cultural facilities."

8 BE IT ENACTED BY THE LEGISLATURE OF THE STATE OF ALASKA:

9 * Section 1. AS 43.18 is amended by adding a new section to read:

10 ARTICLE 5. CULTURAL FACILITIES.

11 Sec. 43.18.500. CULTURAL FACILITY CONSTRUCTION AND DEVELOPMENT

12 GRANTS. (a) There is established within the Department of Commerce and
13 Economic Development a cultural facilities development fund for the pur-
14 pose of providing state assistance in the construction and development
15 of cultural facilities within those municipalities which actively pro-
16 vide support to the arts and humanities. Within the limits of direct
17 appropriations for the purpose or through the appropriation of the
18 proceeds of a general obligation bond issue, the department shall make
19 grants to municipalities for construction and development of cultural
20 facilities.

21 (b) A grant for only one project may be awarded to a municipality
22 under this section.

23 (c) Application for a grant shall be made in the form required by
24 the commissioner.

25 (d) No application for a grant may be considered for approval by
26 the commissioner and no funds paid by him under this section unless

27 (1) the project is endorsed by resolution of the governing
28 body of the sponsoring municipality on its own behalf or on behalf of
29 the officially recognized arts and humanities planning organization of

1 the municipality;

2 (2) the commissioner is satisfied that the sponsoring municipi-
3 pality

4 (A) has the authority under AS 29.41 or AS 29.48 to
5 provide and maintain a cultural facility;

6 (B) is able to provide the local share of project con-
7 struction costs; and

8 (C) will be financially able to maintain and operate the
9 facility upon completion;

10 (3) the municipality provides plan designs and specifica-
11 tions, together with blueprints or schematics of detail sufficient to
12 enable the commissioner to verify estimates of construction costs; and

13 (4) the complete application has been submitted

14 (A) to the state assessor for his determination and
15 verification that the fair market value of any real property
16 claimed as a credit under (f)(4) of this section is accurate; and

17 (B) to the Advisory Commission on Cultural Facilities
18 (AS 44.33.400 - 44.33.410) for its review.

19 (e) The grant to a municipality shall be disbursed in accordance
20 with the terms of an agreement between the commissioner, on behalf of
21 the state, and the governing body of the municipality receiving the
22 grant. The agreement may include any provision agreed upon by the
23 parties, but shall include in substance the following provisions:

24 (1) the municipality shall secure, retain and protect title
25 to the site or location on which the facility is to be constructed or
26 developed; for purposes of this paragraph it is sufficient that title is
27 obtained in fee or by lease by the terms of which the municipality
28 enjoys exclusive use of the land and any improvements for the estimated
29 project life of the facility or the period of maturity of any state

1 general obligation bond a portion of the proceeds of which are used to
2 provide financial assistance for the construction or development of the
3 facility;

4 (2) the municipality agrees to provide the local contribution
5 to project cost required by (f) of this section, and to return to the
6 state any excess contribution by the state as required by (h) of this
7 section;

8 (3) the municipality agrees to proceed with and complete the
9 proposed project expeditiously in accordance with plans originally
10 submitted;

11 (4) the municipality will not materially alter or modify
12 plans for the facility or undertake construction in a manner which
13 materially departs from the approved design and plan for construction or
14 development of the facility without first securing the prior written
15 approval of the officially recognized arts and humanities planning
16 organization of the municipality;

17 (5) the municipality agrees to assume responsibility for the
18 maintenance and operation of the facility, directly or by delegation of
19 responsibility to an entity organized by ordinance of the municipality
20 or to a nonprofit corporation dedicated to the arts and recognized by
21 the municipality; the feasibility of the discharge of this obligation
22 shall be demonstrated to the satisfaction of the commissioner before the
23 payment of any state funds; and

24 (6) the parties agree that if property constructed or deve-
25 loped with financial assistance provided under this section is designed
26 or used for purposes other than for principal use as a cultural facil-
27 ity, the state may require the municipality to reimburse the state for
28 that portion of the market value of the property which the state's
29 investment in the property bears to the total of investment from all

1 sources made in the property.

2 (f) A municipality receiving a grant under this section shall
3 contribute to the total cost of the project. The amount of the munici-
4 pality's contribution is determined by the application of the formula

5 (average per capita assessed valuation of the muni-
6 cipality/average per capita assessed valuation of
7 the state) x contribution percentage

8 to the estimated total project cost as determined by the commissioner at
9 the time of approval of a grant application. For purposes of this
10 subsection

11 (1) the contribution percentage for

12 (A) a municipality having a population of 5,000 or less
13 is 10 per cent;

14 (B) a municipality having a population of 5,001 to
15 10,000 is 20 per cent; and

16 (C) a municipality having a population of more than
17 10,000 is 30 per cent;

18 (2) if an application is submitted for a municipality for
19 which no average per capita assessed valuation has been determined, the
20 commissioner shall request the state assessor to compute the factor and
21 report it to him;

22 (3) the contribution of the municipality may not exceed a
23 rate equal to the contribution percentage established in (1) of this
24 subsection;

25 (4) there shall be allowed as a credit against the municipal-
26 ity's contribution computed under this subsection,

27 (A) for a project involving construction of a new faci-
28 lity, the fair market value of land acquired by the municipality as
29 the site or location for the facility;

1 (B) for a project involving development of an existing
2 structure or facility, the fair market value of the land and im-
3 provements which are acquired by the municipality and committed for
4 use as a cultural facility;

5 (5) the grant awarded by the state may not exceed the esti-
6 mated project cost verified by the commissioner under (d)(3) of this
7 section less the contribution by the municipality determined in accor-
8 dance with this subsection.

9 (g) If funds appropriated or provided by bond issue for grants
10 under this section are not adequate to satisfy amounts required by
11 approved grant applications, funds shall be allocated by the commis-
12 sioner on the basis of priority determined by the Advisory Commission on
13 Cultural Facilities.

14 (h) If, upon completion of the facility, it appears that actual
15 project costs varied substantially from estimated project costs deter-
16 mined by the commissioner under (d)(3) of this section and

17 (1) if the actual contribution of the state exceeds the per-
18 centage of project costs payable by the state determined under (f)(5) of
19 this section, the commissioner shall require the municipality to pay an
20 amount to the state sufficient to reduce the state contribution to the
21 percentage of state contribution required by (f)(5) of this section;

22 (2) if the actual project costs exceed estimates, the commis-
23 sioner may provide additional financial assistance to the municipality;
24 the additional state grant may not exceed an amount equal to the ratio
25 originally determined under (f)(5) of this section applied to the in-
26 cremental project costs.

27 (i) The commissioner shall provide an annual report to the legis-
28 lature with respect to grants made under this section.

29 (j) The commissioner may adopt regulations to carry out the pro-

1 visions of this section.

2 (k) In this section,

3 (1) "commissioner" means the commissioner of commerce and
4 economic development;

5 (2) "construction" means site preparation, erection of a
6 structure, and acquisition and installation of fixtures and necessary
7 fixed equipment, but does not include completion of feasibility studies,
8 site acquisition or facility design;

9 (3) "cultural facility" means a structure or complex the
10 principal purpose of which is to serve the visual and performing arts,
11 including but not limited to a theatre, concert hall or gallery, or to
12 serve as the repository of the historical or contemporary heritage of
13 the community and its people, and which also may be used for compatible
14 activities, including but not limited to, activities relating to educa-
15 tion, community meetings, tourism, and visitor information.

16 (4) "department" means the Department of Commerce and Eco-
17 nomic Development;

18 (5) "development" means the acquisition and preservation, re-
19 modeling or redevelopment of an existing structure or facility, together
20 with the acquisition and installation of fixtures and necessary fixed
21 equipment, for use as a cultural facility.

22 * Sec. 2. AS 44.19.930 is amended by adding a new paragraph to read:

23 (5) to recommend to the governor a list of persons for con-
24 sideration for appointment to the Advisory Commission on Cultural Faci-
25 lities, in accordance with AS 44.33.400.

26 * Sec. 3. AS 44.33 is amended by adding new sections to read:

27 ARTICLE 9. ADVISORY COMMISSION ON CULTURAL
28 FACILITIES.

29 Sec. 44.33.400. ADVISORY COMMISSION ON CULTURAL FACILITIES ESTAB-

1 LISHED. (a) There is in the Department of Commerce and Economic De-
2 velopment the Advisory Commission on Cultural Facilities.

3 (b) The commission consists of five members, appointed by the
4 governor from a list of candidates provided to him for that purpose by
5 the State Council on the Arts. The members of the commission are
6 appointed for overlapping three-year terms, with two of the members
7 first appointed serving three years, two of the members serving two
8 years, and one member serving a term of one year.

9 (c) The commission shall select a chairman and vice-chairman from
10 its membership.

11 Sec. 44.33.405. TRAVEL EXPENSES AND PER DIEM. Members of the
12 Advisory Commission on Cultural Facilities are not entitled to receive
13 compensation for their services, but they shall receive per diem and
14 travel expenses allowed by law for members of boards and commissions for
15 attendance at a maximum of four meetings per year.

16 Sec. 44.33.410. DUTIES. The Advisory Commission on Cultural
17 Facilities shall

18 (1) by regulation, establish criteria for ranking applica-
19 tions for grants to municipalities for the purpose of construction or
20 development of cultural facilities under AS 43.18.500; the regulations
21 shall provide for the assignment of priority among applications trans-
22 mitted by the commissioner, reserving for the highest priority those
23 applications for financial assistance involving the redevelopment or
24 rehabilitation of a structure qualifying as an historic property or a
25 building of historical value which is part of an historical district;
26 the criteria for ranking applications may include facility need and
27 suitability, public support for construction and maintenance of a facil-
28 ity, availability of land, management capacity, alternatives to comple-
29 tion of the facility proposed, and cost;

1 (2) by application of the criteria adopted under (1) of this
2 section, advise the commissioner regarding the approval of requests for
3 financial assistance in the construction of cultural facilities sub-
4 mitted in accordance with AS 43.18.500;

5 (3) at the request of a municipality, provide assistance in
6 the preparation of an assessment of needs and review proposals and plans
7 for construction or development of a cultural facility, for which finan-
8 cial assistance is requested under AS 43.18.500; and

9 (4) submit an annual report to the commissioner and the
10 legislature summarizing its activities and expenses.

11 * Sec. 4. AS 44.33.020 is amended by adding a new paragraph to read:

12 (22) administer the program of state assistance for the
13 construction and development of cultural facilities in accordance with
14 AS 43.18.500.

15 * Sec. 5. AS 29.48.030(14) is amended to read:

16 (14) libraries, visual or performing arts centers, or museums;
17
18
19
20
21
22
23
24
25
26
27
28
29

THE LEGISLATURE OF THE STATE OF ALASKA
TENTH LEGISLATURE

FISCAL NOTE

I. REQUEST

Bill/Resolution No. HB 186

Title Relating to foregiveness of the remaining outstanding school construction debt
~~Request~~ of the City of Hydaburg Date February 17, 1977

Requested by House Judiciary Committee

II. FISCAL DETAIL

Agency Affected Education

Program Category Affected Education

Budget Request Unit(s) Affected Tobacco Tax

EXPENDITURES (Thousands of Dollars)

| | FY 77 | FY 78 | FY 79 | FY 80 | FY 81 | FY 82 |
|--------------------------|----------------|--------------|-------|-------|-------|-------|
| 100 PERSONAL SERVICES | | | | | | |
| 200 TRAVEL | | | | | | |
| 300 CONTRACTUAL | | | | | | |
| 400 COMMODITIES | | | | | | |
| 500 EQUIPMENT | | | | | | |
| 600 LAND & STRUCTURES | | | | | | |
| 700 GRANTS, CLAIMS, ETC. | 189,221 | - 0 - | | | | |
| TOTAL | 189,221 | - 0 - | | | | |

FUNDING (Thousands of Dollars)

| | | | | | | |
|-----------------|---------|-------|--|--|--|--|
| GENERAL FUND | 189,221 | - 0 - | | | | |
| FEDERAL FUNDS | | | | | | |
| OTHER (Specify) | | | | | | |
| | | | | | | |

POSITIONS

| | | | | | | |
|-----------|--|--|--|--|--|--|
| FULL TIME | | | | | | |
| PART TIME | | | | | | |
| TEMPORARY | | | | | | |

III. ANALYSIS (See Fiscal Note Preparation Instructions, Section III)

See Attached

IV. DATE February 17, 1977

PREPARED BY William D. Thomson, Dir. Mgt., Law & Finance
AGENCY Education

Original: Legislative Finance

PHONE 465-2802

cc: Budget and Management

Prime Sponsor (First Legislator Named)

MEMORANDUM

State of Louisiana

TO: [

Chapter 65, SIA 1963

DATE : November 4, 1971

FROM:

SUBJECT: Hydaburg Indebtedness to the State

BOARD OF HYDABURG CAFE SCHOOL DISTRICT --

SCHOOL CONSTRUCTION DEBT

1963

| | |
|---|------------|
| FINAL ACCOUNTING -- TOTAL COST OF PROJECT for State Dep't. of Buildings -- | 200,453.72 |
| Less: District Payments and State Tobacco Tax Allowances as applied -- | 55,282.67 |
| Unpaid Debt Balance as of 1/21/67 | 145,171.05 |
| AV-002210 12/15/67 Transfer of 1967-68 Tobacco Tax entitlement to debt | 1,921.00 |
| Unpaid Balance | 147,092.05 |
| AV-001130 10/9/68 Transfer of 1967-68 Tobacco Tax entitlement to debt | 4,587.04 |
| Unpaid Balance | 151,679.09 |
| AV-000973 10/29/70 Transfer of 1968-69 (3000.40) Cig. Tax entitlement to their debt to the State | 4,221.00 |
| Unpaid Balance | 155,900.09 |
| AV 05-102 11/3/70 (AV-2826 dated 11-11-70) Transfer of 1970-72 Tobacco Tax entitlement to the Hydaburg Debt to the State. | 4,322.00 |
| Unpaid Balance as of 11/3/70 | 160,222.09 |
| AV 05-0084 11/4/71 transfer of 1971-72 Cigarette Tax entitlement to the Hydaburg debt to the State | 4,423.00 |
| Unpaid Balance as of 11/4/71 | 164,645.09 |
| AV 05-05-353 11/22/72 transfer of 1972-73 Cigarette Tax entitlement to the Hydaburg debt to the State | 4,595.00 |
| Unpaid Balance as of 11/22/72 | 169,240.09 |
| AV 05-0068 11/14/73 transf. of 1973-74 Cig. Tax entitlement to the Hydaburg debt to the State | 4,854.00 |
| Unpaid balance as of 11/14/73 | 174,094.09 |
| AV-05-0067 12/2/74 transf. of 1974-75 Cig. Tax entitlement to the Hydaburg debt to the State | 5,006.00 |
| Unpaid balance as of 12-2-74 | 179,100.09 |
| AV-05-FP-0190 12/17/75 transf. of 1975,76 Cig Tax Entitlement to the Hydaburg debt to the State | 5,331.00 |
| Unpaid balance as of | 184,431.09 |
| AV-05-0261 - 2.16/77 transf. of 1976-77 Cig Tax Entitlement to the Hydaburg debt to the State | 7,770.00 |
| Unpaid balance | 192,201.09 |

COMMITTEE REPORT

HOUSE

2-8-77

2/11/77 Date

Mr. Speaker:

The Committee on FINANCE has had HB 186 under consideration. A majority of the members of the Committee

- recommends it do pass
- recommends it do not pass
- recommends it do pass with attached amendment(s)
- recommends it be replaced with CS for _____ and that CS for _____ do pass
- (and) recommends it be referred to the _____ committee
- reports it back without recommendation
- AND attaches a report of its intent
- (other) _____

MEMBERS SIGNING THE MAJORITY REPORT:

| | | |
|--------------------|--------------------|--------------------|
| <u>[Signature]</u> | <u>[Signature]</u> | <u>[Signature]</u> |
| <u>[Signature]</u> | <u>[Signature]</u> | <u>[Signature]</u> |
| <u>[Signature]</u> | <u>[Signature]</u> | <u>[Signature]</u> |
| <u>[Signature]</u> | <u>[Signature]</u> | <u>[Signature]</u> |

MEMBERS NOT CONCURRING IN THE MAJORITY REPORT:

_____ recommends: _____

_____ recommends: _____

_____ recommends: _____

[Signature]
Chairman

Introduced: 2/8/77
Referred: Finance

1 IN THE HOUSE

BY GARDINER AND FREEMAN

2 HOUSE BILL NO. 186

3 IN THE LEGISLATURE OF THE STATE OF ALASKA

4 TENTH LEGISLATURE - FIRST SESSION

5 A BILL

6 For an Act entitled: "An Act relating to forgiveness of the remaining out-
7 standing school construction debt of the City of
8 Hydaburg; and providing for an effective date."

9 BE IT ENACTED BY THE LEGISLATURE OF THE STATE OF ALASKA:

10 * Section 1. Section 4, ch. 85, SLA 1963 is amended to read:

11 Sec. 4. Beginning July 1, 1963, the commissioner of education shall
12 pay annually to the general fund money to which the city becomes entitled
13 from cigarette tax receipts in the "School Fund" as provided by the
14 formula set out in sec. 125(c)(2), subchapter 14, Title 4, Alaska
15 Administrative Code, until the amount paid to the general fund amounts
16 to \$265,000 or until January 1, 1977, whichever occurs first. No money
17 from this source shall be paid to the city until the required payment to
18 the general fund has been made or until the payment termination date of
19 January 1, 1977 has occurred.

20 * Sec. 2. This Act is retroactive to January 1, 1977.

21 * Sec. 3. This Act takes effect immediately in accordance with AS 01.10.-
22 070(c).

23

24

25

26

27

28

29

#

HB186

Chapter 85, SLA 1963

Date: November 4, 1971

Subject: Hydaburg Indebtedness to the State

RECAP OF HYDABURG CITY SCHOOL DISTRICT -
SCHOOL CONSTRUCTION DEBT

| | |
|---|---------------------|
| FINAL ACCOUNTING- TOTAL COST OF PROJECT Per State Dept. of Buldings - | \$294,453.71 |
| Less: District Payments and State Tobacco Tax Allotments as applied - | <u>55,282.67</u> |
| Unpaid Debt Balance as of 4/24/67 ---- | \$239,171.04 |
| AV-002210 12/15/67 Transfer of 1967-68 Tobacco Tax entitlement to debt | 4,927.00 |
| Unpaid Balance - - - | <u>\$234,244.04</u> |
| AV-001130 10/9/68 Transfer of 1967-68 Tobacco Tax entitlement to debt | 4,587.04 |
| Unpaid Balance - - - | <u>\$229,657.00</u> |
| AV-001983 10/29/69 Transfer of 1968-69 (1969-70) T.T. entitlement to their debt to the State - - - | 4,222.00 |
| Unpaid Balance - - - - - | <u>\$225,425.00</u> |
| AV 05-102 11/3/70 (AV-2836 dated 11-11-70) transfer of 1970-71 Tobacco Tax entitlement to the Hydaburg Debt to the State. - - | 4,222.00 |
| Unpaid Balance as of 11/3/70 | <u>\$221,207.00</u> |
| AV 05-0084 11/4/71 transfer of 1971-72 Cigarette Tax entitlement to the Hydaburg debt to the State - - - - - | 4,423.00 |
| Unpaid Balance as of 11/4/71 -AV-004988 - 11-17-71 - - - - - | <u>\$216,784.00</u> |
| AV 05-05-353 11/22/72 transfer of 1972-73 Cigarette Tax entitlement to the Hydaburg debt to the State - - - - - | 4,595.00 |
| Unpaid Balance as of 11/22/72 - - - - - | <u>\$212,189.00</u> |
| AV 05-0068 11/14/73 transf. of 1973-74 Cig. Tax entitlement to the Hydaburg debt to the State - - - - - | 4,854.00 |
| Unpaid balance as of 11/14/73 - - - - - | <u>\$207,335.00</u> |
| AV-05-0067 12/2/74 transf. of 1974-75 Cig. Tax entitlement to the Hydaburg debt to the State - - - - - | 5,006.00 |
| Unpaid balance as of 12-2-74 - - - - - | <u>\$202,329.00</u> |
| AV-05-FP-0190 12/17/75 transf. of 1975,76 Cig Tax Entitlement to the Hydaburg debt to the State - - - - - | 5,388. |
| Unpaid balance as of- - - - - | <u>\$196,991.00</u> |
| AV-05-0261 - 2.16/77 transf. of 1976-77 Cig Tax Entitlement to the Hydaburg debt to the State - - - - - | 7,770. |
| Unpaid balance | <u>\$189,221.</u> |

TO: [

Chapter 85, SIA 1963

DATE : November 4, 1971

FROM:

SUBJECT: Hydaburg Indentures to the State

RECAP OF HYDABURG CITY SCHOOL DISTRICT -
SCHOOL CONSTRUCTION DEBT

| | |
|---|------------|
| FINAL ACCOUNTING - TOTAL COST OF PROJECT Per State Dept. of Buildings | 294,453.71 |
| Less: District Payments and State Tobacco Tax Allotments as applied | 55,282.67 |
| Unpaid Debt Balance as of 1/21/67 | 239,171.04 |
| AV-002210 12/15/67 Transfer of 1967-68 Tobacco Tax entitlement to debt | 4,927.00 |
| Unpaid Balance | 234,244.04 |
| AV-001130 10/9/68 Transfer of 1967-68 Tobacco Tax entitlement to debt | 4,587.04 |
| Unpaid Balance | 229,657.00 |
| AV-001903 10/22/69 Transfer of 1968-69 (1969-70) Tobacco Tax entitlement to their debt to the State | 4,222.00 |
| Unpaid Balance | 225,435.00 |
| AV 05-102 11/3/70 (AV-2826 dated 11-11-70) Transfer of 1970-71 Tobacco Tax entitlement to the Hydaburg Debt to the State. | 4,222.00 |
| Unpaid Balance as of 11/3/70 | 221,213.00 |
| AV 05-0084 11/4/71 transfer of 1971-72 Cigarette Tax entitlement to the Hydaburg debt to the State | 4,423.00 |
| Unpaid Balance as of 11/4/71 | 216,790.00 |
| AV 05-05-353 11/22/72 transfer of 1972-73 Cigarette Tax entitlement to the Hydaburg debt to the State | 4,595.00 |
| Unpaid Balance as of 11/22/72 | 212,195.00 |
| AV 05-0068 11/14/73 transf. of 1973-74 Cig. Tax entitlement to the Hydaburg debt to the State | 4,854.00 |
| Unpaid balance as of 11/14/73 | 207,341.00 |
| AV-05-0067 12/2/74 transf. of 1974-75 Cig. Tax entitlement to the Hydaburg debt to the State | 5,006.00 |
| Unpaid balance as of 12-2-74 | 202,335.00 |
| AV-05-FP-0190 12/17/75 transf. of 1975,76 Cig Tax Entitlement to the Hydaburg debt to the State | 5,333.00 |
| Unpaid balance as of | 196,991.00 |
| AV-05-0261 - 2.16/77 transf. of 1976-77 Cig Tax Entitlement to the Hydaburg debt to the State | 7,770.00 |
| Unpaid balance | 189,221.00 |

Introduced: 2/8/77
Referred: Finance

1 IN THE HOUSE

BY GARDINER AND FREEMAN

2 HOUSE BILL NO. 186

3 IN THE LEGISLATURE OF THE STATE OF ALASKA

4 TENTH LEGISLATURE - FIRST SESSION

5 A BILL

6 For an Act entitled: "An Act relating to forgiveness of the remaining out-
7 standing school construction debt of the City of
8 Hydaburg; and providing for an effective date."

9 BE IT ENACTED BY THE LEGISLATURE OF THE STATE OF ALASKA:

10 * Section 1. Section 4, ch. 85, SLA 1963 is amended to read:

11 Sec. 4. Beginning July 1, 1963, the commissioner of education shall
12 pay annually to the general fund money to which the city becomes entitled
13 from cigarette tax receipts in the "School Fund" as provided by the
14 formula set out in sec. 125(c)(2), subchapter 14, Title 4, Alaska
15 Administrative Code, until the amount paid to the general fund amounts
16 to \$265,000 or until January 1, 1977, whichever occurs first. No money
17 from this source shall be paid to the city until the required payment to
18 the general fund has been made or until the payment termination date of
19 January 1, 1977 has occurred.

20 * Sec. 2. This Act is retroactive to January 1, 1977.

21 * Sec. 3. This Act takes effect immediately in accordance with AS 01.10.-
22 070(c).

23

24

25

26

27

28

29

#



RECORDS CERTIFICATION

I, the undersigned, an employee of the State of Alaska, do hereby certify that the microfilm images on this microform are accurate reproductions of the original records of the State of Alaska as accumulated during the regular course of business, and that it is the established policy and practice of this State to microfilm its records and to dispose of the original records after microfilm reproductions have been made.

James O. Smith
Signature of Camera Operator

2/14/90
Date

COMMITTEE REPORT
SENATE

3/29/77

_____ Date

Mr. President:

The Committee on FINANCE has had HR 104
forgiveness of the remaining outstanding school construction debt of the City of
under consideration. A majority of the members of the Committee Hydaburg

- recommends it do pass
- recommends it do not pass
- recommends it do pass with attached amendment(s)
- recommends it be replaced with CS for _____ and that
CS for _____ do pass
- (and) recommends it be referred to the _____
committee
- reports it back without recommendation
- AND attaches a report of its intent
- (other) Subcommittee Report

MEMBERS SIGNING THE MAJORITY REPORT:

MEMBERS NOT CONCURRING IN THE MAJORITY REPORT:

_____ recommends: _____

_____ recommends: _____

_____ recommends: _____

_____ Chairman

Introduced: 2/8/77
Referred: Finance

1 IN THE HOUSE

BY GARDINER AND FREEMAN

2 HOUSE BILL NO. 186

3 IN THE LEGISLATURE OF THE STATE OF ALASKA

4 TENTH LEGISLATURE - FIRST SESSION

5 A BILL

6 For an Act entitled: "An Act relating to forgiveness of the remaining out-
7 standing school construction debt of the City of
8 Hydaburg; and providing for an effective date."

9 BE IT ENACTED BY THE LEGISLATURE OF THE STATE OF ALASKA:

10 * Section 1. Section 4, ch. 85, SLA 1963 is amended to read:

11 Sec. 4. Beginning July 1, 1963, the commissioner of education shall
12 pay annually to the general fund money to which the city becomes entitled
13 from cigarette tax receipts in the "School Fund" as provided by the
14 formula set out in sec. 125(c)(2), subchapter 14, Title 4, Alaska
15 Administrative Code, until the amount paid to the general fund amounts
16 to \$265,000 or until January 1, 1977, whichever occurs first. No money
17 from this source shall be paid to the city until the required payment to
18 the general fund has been made or until the payment termination date of
19 January 1, 1977 has occurred.

20 * Sec. 2. This Act is retroactive to January 1, 1977.

21 * Sec. 3. This Act takes effect immediately in accordance with AS 01.10.-
22 070(c).

23

24

25

26

27

28

29

#

Unless B are appropriated
or 1963 Act repealed all
Hydeburgs Tobacco Tax
revenue must go to
pay off debt.

HB 186

5/10/77

Judy Crondall -

Copies of the back-up
re HB 186 were
given for distribution
to the files of all
Senate Finance Committee
members today.

Chotki Anget
for Terry Gardner

TO: [

Chapter 65, SLA 1963

DATE : November 4, 1971

FROM:

SUBJECT: Hydaburg Indebtedness to the State

RECAP OF HYDABURG CITY SCHOOL DISTRICT -
SCHOOL CONSTRUCTION DEBT

| | |
|---|------------------|
| FINAL ACCOUNTING - TOTAL COST OF PROJECT Per State Dep't. of Buildings - | \$294,453.71 |
| Less: District Payments and State Tobacco Tax Allotments as applied - | <u>55,262.67</u> |
| Unpaid Debt Balance as of 1/24/67 - - - - | \$239,171.04 |
| AV-002210 12/15/67 Transfer of 1967-68 Tobacco Tax entitlement to debt | <u>1,927.00</u> |
| Unpaid Balance - - - | \$241,098.04 |
| AV-001130 10/9/68 Transfer of 1967-68 Tobacco Tax entitlement to debt | <u>1,581.04</u> |
| Unpaid Balance - - - | \$ 242,679.08 |
| AV-001933 10/20/69 Transfer of 1968-69 (1969-70) T.T. entitlement | |
| to their debt to the State - - - | <u>4,228.00</u> |
| Unpaid Balance - - - - - | \$ 246,907.08 |
| AV 05-102 11/3/70 (AV-2836 dated 11-11-70) transfer of 1970-71 | |
| Tobacco Tax entitlement to the Hydaburg Debt to the State. - - - | <u>4,222.00</u> |
| Unpaid Balance as of 11/3/70 - - - - - | \$251,129.08 |
| AV 05-0084 11/4/71 transfer of 1971-72 Cigarette Tax entitlement to the | |
| Hydaburg debt to the State - - - - - | <u>4,423.00</u> |
| Unpaid Balance as of 11/4/71 AV-007988 - 11-17-71 - - - - - | \$216,784.00 |
| AV 05-05-353 11/22/72 transfer of 1972-73 Cigarette Tax entitlement to the | |
| Hydaburg debt to the State - - - - - | <u>4,595.00</u> |
| Unpaid Balance as of 11/22/72 - - - - - | \$212,189.00 |
| AV 05-0068 11/14/73 transf. of 1973-74 Cig. Tax entitlement to the Hydaburg | |
| debt to the State - - - - - | <u>4,854.00</u> |
| Unpaid balance as of 11/14/73 - - - - - | \$207,335.00 |

[Handwritten signature]
11-3-71

HYDABURG SCHOOL LOAN AND INDEBTEDNESS TO THE STATE OF ALASKA

REFERENCE: Chapter 85, SLA 1963

Final cost of Building - PROJECT COST per State Dep't. of Public Works - Bldgs. Division :

\$294,453.71

RECORD OF PAYMENTS AND APPLICATIONS OF ANNUAL STATE TOBACCO TAX ALLOTMENTS

| Date | Document # | Explanation | Amount of Payments | UNPAID BALANCE |
|----------|------------|---|--------------------|----------------|
| 6/13/63 | By DFW | Hydaburg School Dist. Tobacco Tax Account Check received by the Dep't. of Public Works. Carbon copy submitted to the Dep't. of Education. Per Chapter 85, SLA 1963 - Sec. 1 (a) | \$35,000.00 | \$259,453.71 |
| 2/13/64 | AV-006016 | 1962-63 T. T. Allotment applied to debt | 5,297.64 | 254,156.07 |
| 12/21/64 | AV-05-90 | 1963-64 Balance of T. T. Allotment applied to their debt | 1,299.75 | 252,856.32 |
| 10/15/65 | TR-971 | Hydaburg School refunded 1963-64 Est. 75% of T. T. to Dep't. of Education -applied to their debt. | 4,015.00 | 248,841.32 |
| 1/31/66 | AV-002465 | 1964-65 T. T. Allotment applied to Debt | 4,755.28 | 244,086.04 |

NOTE: In yrs. following, T. T. Allocations described differently.

| | | | | |
|----------|-----------|--|----------|------------|
| 4/15/67 | AV-003310 | 1966-67 T. T. Allocation applied to Debt | 4,915.00 | 239,171.04 |
| 12/15/67 | AV-002210 | 1967-68 " " " " " " | 4,927.00 | 234,244.04 |
| 10/9/68 | AV-001130 | 1968-69 " " " " " " | 4,587.04 | 229,657.00 |
| 10/20/69 | AV-001983 | 1969-70 " " " " " " | 4,228.00 | 225,429.00 |
| 11/11/70 | AV-002836 | 1970-71 " " " " " " | 4,222.00 | 221,207.00 |

STATE OF ALASKA
DEPARTMENT OF EDUCATION

TO: Dep't. Public Works
Buildings Division
SUBJECT: Mrs. Madeline Sturma

FROM: Jack Popejoy - Room # 302B
Alaska Office Bldg.
DATE: 1/20/67

M Subject: Hydaburg School Construction - See Chapter 85, SLA 1963- Estimated
cost of the facility @ \$300,000.00

- E 1. Has the Hydaburg School Been completed yet?
- S 2. What was the final Cost?
- S 3. Has the title been turned over to the City of Hydaburg yet?

| | | | |
|---|---|-------|-------------------|
| A | Estimated costs | ----- | \$300,000.00 |
| G | Less Hydaburg payments and credits of their annual Tobacco Tax allotments since 6/5/65 | ----- | 55,272.67 |
| E | Balance of debt as we now show it without the final costs. | ----- | <u>244,727.33</u> |

CP

- R 1. Yes, February 24, 1965
- E 2. \$ 294,453.71 See attachment
- L 3. Yes, Warranty Deed to property given to City of Hydaburg Sept. 20, 1965

H. Sturma, Div. Bldgs

Y FILE NO.:

ORIGINATOR: RETAIN PINK COPY. SEND REMAINING THREE WITH CARBON INTACT.

REPLIER: WHEN REPLYING - REMOVE CARBONS - RETURN WHITE COPY TO ORIGINATOR. RETAIN YELLOW COPY FOR FILE, SUBMIT GOLDENROD COPY TO COMMISSIONER'S OFFICE, A.P.O. OR A.D.B. AS APPLICABLE.

HYDABURG SCHOOL PROJECT

| | |
|---------------------|--------------------|
| Ch 85, SLA 1963 | \$ 265,000. |
| City of Hydaburg | <u>35,000.</u> |
| Total Authorization | <u>\$ 300,000.</u> |

Costs:

Architectural & Engineering:

| | | |
|--------------------------------|---------------|--------------|
| Contract, Olsen & Sands | \$ 18,102.00 | |
| Kitchen Design, Olsen & Sands | 250.00 | |
| Plans & Specs, " " | 142.00 | |
| Travel, " " | 1,468.31 | |
| Site Survey, Furuseth & Ekness | <u>624.00</u> | \$ 20,586.31 |

Bid Advertising

41.70

Construction:

| | |
|---------------------------------|-----------------|
| Contract, 49th Construction Co. | \$ 250,170.00 |
| Change Order No. 1 | 9,780.00 |
| " " " 2 | 150.00 |
| " " " 3 | 2,596.80 |
| " " " 4 | (1,413.25) |
| " " " 5 | (5,611.50) |
| Electrical Changes | <u>1,695.00</u> |
| Total Contract | \$ 257,567.05 |

Repairs by the Division of Buildings
(Reflected in Change Order No. 5)

| | |
|--------------------------------------|---------------|
| Electrical Contract | 1,695.00 |
| Repairs on Power Plant | 75.95 |
| Materials, Freight, Equipment Rental | 1,592.72 |
| Payroll, State Employees | 2,445.44 |
| Travel & Per Diem, | 989.39 |
| B & G Booster | <u>102.96</u> |
| | \$ 6,899.46 |

Total Construction . \$ 264,266.51

Supervision

| | | |
|--------------------------------|-----------------|----------|
| Furuseth & Ekness | \$ 2,636.50 | |
| J. Donald Kroeker (Mechanical) | 274.09 | |
| Buildings Division | <u>1,524.23</u> | 4,434.82 |

Equipment

5,124.37

Total cost of Project \$ 294,453.71

| | |
|---------------|--------------------|
| Authorization | \$ 300,000.00 |
| Costs | <u>294,453.71</u> |
| Balance | \$ <u>5,546.29</u> |

Department of Education
 School Building Project
 Chap. 25, S.H.A. 1948

| | |
|-------------|------|
| INITIALS | DATE |
| PREPARED BY | |
| APPROVED BY | |

| LINE No. | | (2) | (3) | (4) |
|----------|-------------|---------|--------|----------|
| 1 | | | | 2500000 |
| 2 | | | | |
| 3 | Actual cost | | | 2500000 |
| 4 | | | | 2500000 |
| 5 | | 1947-48 | 557964 | 25415639 |
| 6 | | 1948-49 | 531135 | 24884130 |
| 7 | | 1949-50 | 115252 | 24126302 |
| 8 | | 1950-51 | 281500 | 23917130 |
| 9 | | 1951-52 | 492700 | 23124404 |
| 10 | | | | |
| 11 | | | | |
| 12 | | | | |
| 13 | | | | |
| 14 | | | | |
| 15 | | | | |
| 16 | | | | |
| 17 | | | | |
| 18 | | | | |
| 19 | | | | |
| 20 | | | | |
| 21 | | | | |
| 22 | | | | |
| 23 | | | | |
| 24 | | | | |
| 25 | | | | |
| 26 | | | | |
| 27 | | | | |
| 28 | | | | |
| 29 | | | | |
| 30 | | | | |
| 31 | | | | |
| 32 | | | | |
| 33 | | | | |
| 34 | | | | |
| 35 | | | | |
| 36 | | | | |
| 37 | | | | |
| 38 | | | | |
| 39 | | | | |
| 40 | | | | |

Introduced: 4/7/75
Referred: Health, Education &
Social Services and Finance

1 IN THE HOUSE

BY FREEMAN AND GARDINER

2 HOUSE BILL NO. 386

3 IN THE LEGISLATURE OF THE STATE OF ALASKA

4 NINTH LEGISLATURE - FIRST SESSION

5 A BILL

6 For an Act entitled: "An Act relating to forgiveness of the remaining out-
7 standing school construction debt of the City of
8 Hydaburg; and providing for an effective date."

9 BE IT ENACTED BY THE LEGISLATURE OF THE STATE OF ALASKA:

10 * Section 1. Chapter 85, sec. 4, SLA 1963 is amended to read:

11 Sec. 4. Beginning July 1, 1963, the commissioner of education
12 shall pay annually to the general fund money to which the city becomes
13 entitled from cigarette tax receipts in the "School Fund" as provided
14 by the formula set out in sec. 125(c)(2), subchapter 14, Title 4,
15 Alaska Administrative Code, until the amount paid to the general fund
16 amounts to \$265,000 or until January 1, 1975, whichever occurs first.
17 No money from this source shall be paid to the city until the required
18 payment to the general fund has been made or until the payment termina-
19 tion date of January 1, 1975 has occurred.

20 * Sec. 2. This Act is retroactive to January 1, 1975.

21 * Sec. 3. This Act takes effect immediately in accordance with AS 01.10.-
22 070(c).

Chapter 65, SBA 1963

DATE : November 4, 1971

FROM:

SUBJECT: Hydaburg City School District

BOARD OF HYDABURG CITY SCHOOL DISTRICT -
SCHOOL CONSTRUCTION DEBT

FINAL ACCOUNTING - TOTAL COST OF PROJECT For State Dept. of Buildings - 424,450.00

Less: District Payments and State Tobacco Tax Allowance as applied - 15,232.00

Unpaid Debt Balance as of 1/2/67 - 409,218.00

AV-00210 12/15/67 Transfer of 1967-68 Tobacco Tax entitlement to debt
Unpaid Balance - 1,222.00

AV-00130 10/9/68 Transfer of 1967-68 Tobacco Tax entitlement to debt
Unpaid balance - 1,222.00

AV-00130 10/27/68 Transfer of 1968-69 (0010-10) Tobacco Tax entitlement
to their debt to the State - 1,222.00

Unpaid balance - 1,222.00

AV 05-009 11/3/70 (AV-2236 dated 11-11-70) Transfer of 1970-71
Tobacco Tax entitlement to the Hydaburg Debt to the State - 1,222.00

Unpaid balance as of 11/3/70 - 1,222.00

AV 05-0084 11/4/71 transfer of 1971-72 Cigarette Tax entitlement to the
Hydaburg debt to the State - 4,423.00

Unpaid Balance as of 11/4/71 - 4-17-71 - 4,423.00

AV 05-05-353 11/22/72 transfer of 1972-73 Cigarette Tax entitlement to the
Hydaburg debt to the State - 4,595.00

Unpaid Balance as of 11/22/72 - 4,595.00

AV 05-0068 11/14/73 transf. of 1973-74 Cig. Tax entitlement to the Hydaburg
debt to the State - 4,854.00

Unpaid balance as of 11/14/73 - 4,854.00

AV-05-0067 12/2/74 transf. of 1974-75 Cig. Tax entitlement to the Hydaburg
debt to the State - 5,006.00

Unpaid balance as of 12-2-74 - 5,006.00

AV-05-FP-0190 12/17/75 transf. of 1975,76 Cig Tax Entitlement to the
Hydaburg debt to the State - 5,330.00

Unpaid balance as of - 5,330.00

AV-05-0261 - 2.16/77 transf. of 1976-77 Cig Tax Entitlement to the
Hydaburg debt to the State - 7,770.00

Unpaid balance - 7,770.00

\$189,221.00

TENTH LEGISLATURE

FISCAL NOTE

I. REQUEST
 Bill/Resolution No. HB 186
 Title Relating to foregiveness of the remaining outstanding school construction debt
~~XXXXXXXXXXXX~~ of the City of Hydaburg Date February 17, 1977

Requested by House Judiciary Committee

II. FISCAL DETAIL
 Agency Affected Education
 Program Category Affected Education
 Budget Request Unit(s) Affected Tobacco Tax

EXPENDITURES (Thousands of Dollars)

| | FY 77 | FY 78 | FY 79 | FY 80 | FY 81 | FY 82 |
|--------------------------|----------------|--------------|-------|-------|-------|-------|
| 100 PERSONAL SERVICES | | | | | | |
| 200 TRAVEL | | | | | | |
| 300 CONTRACTUAL | | | | | | |
| 400 COMMODITIES | | | | | | |
| 500 EQUIPMENT | | | | | | |
| 600 LAND & STRUCTURES | | | | | | |
| 700 GRANTS, CLAIMS, ETC. | 189,221 | - 0 - | | | | |
| TOTAL | 189,221 | - 0 - | | | | |

FUNDING (Thousands of Dollars)

| | | | | | | |
|-----------------|---------|-------|--|--|--|--|
| GENERAL FUND | 189,221 | - 0 - | | | | |
| FEDERAL FUNDS | | | | | | |
| OTHER (Specify) | | | | | | |
| | | | | | | |

POSITIONS

| | | | | | | |
|-----------|--|--|--|--|--|--|
| FULL TIME | | | | | | |
| PART TIME | | | | | | |
| TEMPORARY | | | | | | |

III. ANALYSIS (See Fiscal Note Preparation Instructions, Section III)

See Attached

IV. DATE February 17, 1977 PREPARED BY William D. Thomson, Dir. Mgt., Law & Finance
 AGENCY Education
 PHONE 465-2802

Original: Legislative Finance
 cc: Budget and Management
 Prime Sponsor (First Legislator Named)

Terry Gardiner

Box 6092, Ketchikan, Alaska 99901 Pouch V, Juneau, Alaska 99811

April 6, 1977

Memo

To: Senator John Sackett

From; Rep. Gardiner *T.G.*

Re: HB 186, Forgiveness of remaining school construction
debt to the City of Hydaburg

HB 186 is directed at a school debt that the City of Hydaburg owes the State for construction of a grade school in 1963. Throughout recent years the State has forgiven the outstanding debt from such school districts as Kake, Dillingham, and Bristol Bay for similar types of debt. The bill is a forgiveness of monies owed the State and not an appropriation. Although the fiscal note shows an impact of \$189,221.00 to the State, this is not quite correct. Each year the City of Hydaburg pays its tax entitlement for tobacco tax to the State of Alaska to pay off the existing debt. If this bill were to pass, the City of Hydaburg would not be required to pay this tobacco tax money to the State. This bill would not require an appropriation of general fund monies.

The City of Hydaburg has been growing in recent years and can certainly use the small amounts of money we are talking about to fund the operations of their municipality government and school systems. If you need any further information, please let me know.

John -

See attached next 2 pages.

Judy

| Outstanding Bonds | Principal P. 1974 | * Estimated 1975-74 | Total |
|-------------------|-------------------|---------------------|----------|
| Anchorage | 98,081.0 | 5,900.0 | 103,981 |
| Bristol Bay | 170.0 | - 0 - | 170 |
| Cordova | 1,444.6 | 25,000.0 | 1,444 |
| Craig | - 0 - | - 0 - | |
| Dillingham | - 0 - | - 0 - | |
| Fairbanks | 4,213.0 | 25,000.0 | 29,213 |
| Galena | - 0 - | - 0 - | |
| Haines | 870.0 | - 0 - | 870.0 |
| Hoonah | - 0 - | - 0 - | - 0 - |
| Hydaburg | - 0 - | - 0 - | - 0 - |
| Juneau | 5,123.0 | 2,500.0 | 7,623.0 |
| Kake | - 0 - | - 0 - | - 0 - |
| Kenai | 14,783.0 | 8,000.0 | 22,783.0 |
| Ketchikan | 5,566.0 | - 0 - | 5,566.0 |
| King Cove | - 0 - | - 0 - | - 0 - |
| Klawock | - 0 - | - 0 - | - 0 - |
| Kodiak | 4,370.0 | - 0 - | 4,370.0 |
| Mat-Su | 8,015.0 | * 14,800.0 | 22,815.0 |
| Nenana | 259.0 | - 0 - | 259.0 |
| Nome | - 0 - | - 0 - | |
| Pelican | - 0 - | - 0 - | |
| Petersburg | 1,035.0 | * 2,850.0 | 3,885.0 |
| Sitka | 3,706.0 | - 0 - | 3,706.0 |
| Tioga | 159.0 | - 0 - | 159.0 |
| St. Mary's | - 0 - | - 0 - | - 0 - |

| | | | |
|---------------------|-----------|------------|-----------|
| UNALASKA | -0- | | -0- |
| VALDEZ | -0- | * 12,000.0 | 12,000. |
| WRANGELL | 135.0 | | 135. |
| YAKUTAT | -0- | | -0- |
| NORTH SLOPE BOROUGH | -0- | * 10,000.0 | 10,000.0 |
| Sub TOTAL | 147,931.6 | 81,050.0 | 228,981.6 |

* Construction in 1974
 Grand Total Outstanding Principal Est. \$ 228,981.6

Does not include any penalties for early payments.

| | | | |
|--------|------|-----------|-------------------------|
| Sec. 1 | Est. | 250,000.0 | One Time with penalties |
| Sec. 2 | Est. | 11,400.0 | 2) Years 1978-82 |
| Sec. 3 | Est. | 27,000.0 | Annual |

3/21

Terry -

Bill Thomson's office at the
Dypt. of Education had the
following info:

| | |
|---------------------------------|-----------------|
| Total cost of Hyderabad project | \$ 294,453.71 |
| Unpaid balance | - \$ 189,221.00 |
| Paid to date | \$ 105,232.71 |

(Above figures from
attachment to fiscal note)

Chotie

MEMORANDUM

State of Alaska

TO: [

Chapter 65, SLA 1963

DATE : November 4, 1971

FROM:

SUBJECT: Hydaburg Indebtedness to the State

RECAP OF HYDABURG CITY SCHOOL DISTRICT -

SCHOOL CONSTRUCTION DEBT

| | |
|---|----------------------|
| FINAL ACCOUNTING - TOTAL COST OF PROJECT Per State Dep't. of Buildings - | \$294,453.71 |
| Less: District Payments and State Tobacco Tax Allotments as applied - | <u>55,232.57</u> |
| Unpaid Debt Balance as of 1/24/67 - - - - | \$239,171.04 |
| AV-002210 12/15/67 Transfer of 1967-68 Tobacco Tax entitlement to debt | 1,927.00 |
| Unpaid Balance - - - - | <u>\$241,098.04</u> |
| AV-001130 10/9/68 Transfer of 1967-68 Tobacco Tax entitlement to debt | 1,537.94 |
| Unpaid Balance - - - - | <u>\$ 242,635.98</u> |
| AV-001935 10/29/69 Transfer of 1968-69 (1969-70) T.V. entitlement | |
| to their debt to the State - - - - | 4,225.00 |
| Unpaid Balance - - - - - | <u>\$ 246,860.98</u> |
| AV 05-102 11/3/70 (AV-2836 dated 11-11-70) transfer of 1970-71 | |
| Tobacco Tax entitlement to the Hydaburg Debt to the State. - - - | 4,222.00 |
| Unpaid Balance as of 11/3/70 - - - - - | <u>\$251,082.98</u> |
| AV 05-0084 11/4/71 transfer of 1971-72 Cigarette Tax entitlement to the | |
| Hydaburg debt to the State - - - - - | 4,423.00 |
| Unpaid Balance as of 11/4/71 AV-201228 11-17-71 - - - - - | <u>\$216,784.00</u> |
| AV 05-05-353 11/22/72 transfer of 1972-73 Cigarette Tax entitlement to the | |
| Hydaburg debt to the State - - - - - | 4,595.00 |
| Unpaid Balance as of 11/22/72 - - - - - | <u>\$212,189.00</u> |
| AV 05-0068 11/14/73 transf. of 1973-74 Cig. Tax entitlement to the Hydaburg | |
| debt to the State - - - - - | 4,854.00 |
| Unpaid balance as of 11/14/73 - - - - - | <u>\$207,335.00</u> |

J.P. [unclear]
11-3-71

HYDABURG SCHOOL LOAN AND INDEBTEDNESS TO THE STATE OF ALASKA

REFERENCE: Chapter 85, SLA 1963

Final cost of Building - PROJECT COST per State Dep't. of Public Works - Bldgs. Division :
\$294,453.71

RECORD OF PAYMENTS AND APPLICATIONS OF ANNUAL STATE TOBACCO TAX ALLOTMENTS

| Date | Document # | Explanation | Amount of Payments | UNPAID BALANCE |
|---|------------|---|--------------------|----------------|
| 6/13/63 | By DFW | Hydaburg School Dist. Tobacco Tax Account Check received by the Dep't. of Public Works. Carbon copy submitted to the Dep't. of Education. Per Chapter 85, SLA 1963 - Sec. 1 (A) | \$35,000.00 | \$259,453.71 |
| 2/13/64 | AV-006016 | 1962-63 T. T. Allotment applied to debt | 5,297.64 | 254,156.07 |
| 12/21/64 | AV-05-90 | 1963-64 Balance of T. T. Allotment applied to their debt | 1,299.75 | 252,856.32 |
| 10/15/65 | TR-971 | Hydaburg School refunded 1963-64 Est. 75% of T. T. to Dep't. of Education - applied to their debt. | 4,015.00 | 248,841.32 |
| 1/31/66 | AV-002465 | 1964-65 T. T. Allotment applied to Debt | 4,755.28 | 244,086.04 |
| NOTE: In yrs. following, T. T. Allocations described differently. | | | | |
| 4/15/67 | AV-003310 | 1966-67 T. T. Allocation applied to Debt | 4,915.00 | 239,171.04 |
| 12/15/67 | AV-002210 | 1967-68 " " " " " " | 4,927.00 | 234,244.04 |
| 10/9/68 | AV-001130 | 1968-69 " " " " " " | 4,587.04 | 229,657.00 |
| 10/20/69 | AV-001983 | 1969-70 " " " " " " | 4,228.00 | 225,429.00 |
| 11/11/70 | AV-002836 | 1970-71 " " " " " " | 4,222.00 | 221,207.00 |

STATE OF ALASKA
DEPARTMENT OF EDUCATION

TO: *TO:*
Dep't. Public Works
Buildings Division
SUBJECT: Mrs. Madeline Sturn

FROM: Jack Popejoy - Room # 309B
Alaska Office Bldg.
DATE: 1/20/67

Subject: Hydaburg School Construction - See Chapter 85, SLA 1963- Estimated cost of the facility @ \$300,000.00

1. Has the Hydaburg School Been completed yet?
2. What was the final cost?
3. Has the title been turned over to the City of Hydaburg yet?

| | | |
|--|-------|----------------------------|
| Estimated costs | ----- | \$300,000.00 |
| Less Hydaburg payments and credits of their annual Tobacco Tax allotments since 6/6/63 | ----- | <u>55,262.67</u> |
| Balance of debt as we now show it without the final costs. | ----- | <u><u>\$244,737.33</u></u> |

CP

1. Yes, February 24, 1965
2. \$ 294,453.71 See attachment
3. Yes, Warranty Deed to property given to City of Hydaburg Sept. 20, 1965

H. Sturn, Div. Bldgs

FILE NO:

ORIGINATOR: RETAIN PINK COPY. SEND REMAINING THREE WITH CARSON INTACT.

REPLIER: WHEN REPLYING - REMOVE CARBONS - RETURN WHITE COPY TO ORIGINATOR. RETAIN YELLOW COPY FOR FILE. SUBMIT GOLDENROD COPY TO COMMISSIONER'S OFFICE, A.F.O. OR A.O.D. AS APPLICABLE.

HYDABURG SCHOOL PROJECT

| | |
|---------------------|--------------------|
| Ch 85, SEA 1963 | \$ 265,000. |
| City of Hydaburg | 35,000. |
| Total Authorization | <u>\$ 300,000.</u> |

Costs:

| | | |
|---|-----------------|----------------------|
| <u>Architectural & Engineering:</u> | | |
| Contract, Olson & Sands | \$ 18,102.00 | |
| Kitchen Design, Olson & Sands | 250.00 | |
| Plans & Specs, " " | 142.00 | |
| Travel, " " | 1,468.31 | |
| Site Survey, Furuseth & Ekness | <u>624.00</u> | \$ 20,586.31 |
| Bid Advertising | | 41.70 |
| <u>Construction:</u> | | |
| Contract, 49th Construction Co. | \$ 250,170.00 | |
| Change Order No. 1 | 9,780.00 | |
| " " " 2 | 150.00 | |
| " " " 3 | 2,596.80 | |
| " " " 4 | (1,413.25) | |
| " " " 5 | (5,611.50) | |
| Electrical Changes | <u>1,695.00</u> | |
| Total Contract | \$ 257,367.05 | |
| Repairs by the Division of Buildings (Reflected in Change Order No. 5) | | |
| Electrical Contract | 1,695.00 | |
| Repairs on Power Plant | 75.95 | |
| Materials, Freight, Equipment Rental | 1,592.72 | |
| Payroll, State Employees | 2,445.44 | |
| Travel & Per Diem, | 989.39 | |
| B & G Booster | <u>102.96</u> | |
| | \$ 6,899.46 | \$ 264,266.51 |
| Total Construction | | |
| <u>Supervision</u> | | |
| Furuseth & Ekness | \$ 2,636.50 | |
| J. Donald Kroeker (Mechanical) | 274.09 | |
| Buildings Division | <u>1,524.23</u> | 4,434.82 |
| <u>Equipment</u> | | |
| | | <u>5,124.37</u> |
| Total cost of Project | | <u>\$ 294,453.71</u> |

| | |
|---------------|--------------------|
| Authorization | \$ 300,000.00 |
| Costs | <u>294,453.71</u> |
| Balance | <u>\$ 5,546.29</u> |

School Building Project
Chapter 25, S.A. 1913

PREPARED BY _____
 APPROVED BY _____

LINE NO
 1
2
3
4
5
6
7
8
9
10
11
12
13
14
15
16
17
18
19
20
21
22
23
24
25
26
27
28
29
30
31
32
33
34
35
36
37
38
39
40

1917-18

1918-19
1919-20
1920-21
1921-22
1922-23
1923-24
1924-25
1925-26
1926-27
1927-28
1928-29
1929-30
1930-31
1931-32
1932-33
1933-34
1934-35
1935-36
1936-37
1937-38
1938-39
1939-40

Distribution

(see attached sheet)

35000.00

1917-18

5579.64

1918-19

5314.85

1919-20

11953.58

1920-21

2015.00

1921-22

4987.01

25000.00

95000.00

55915.71

351156.39

248841.30

241563.21

539171.20

331244.04

Chapter 85, SLA 1963

PREPARED BY _____
 APPROVED BY _____

(1) (2) (3) (4)

| LINE NO | Description | (1) | (2) | (3) | (4) | LINE NO |
|---------|---|-----|--------|---------|----------|---------|
| | Chapter 85 SLA 1963 Int. Collection | | | | 26500000 | |
| 1 | Estimated Cost of Project | | | | 42000000 | 1 |
| 2 | Estimated Expense & Actual Cost | | | | 551637 | 2 |
| 3 | Actual Cost | | | | 551637 | 3 |
| 4 | From City of Hyderabad Payment | | 25000 | | 25741501 | 4 |
| 5 | Int. Collection applied to Int. Expense 1782-24 | | 539701 | | 25741501 | 5 |
| 6 | | | 45 | 534195 | 25741502 | 6 |
| 7 | | | 47 | 1195528 | 25741503 | 7 |
| 8 | | | 47 | 491500 | 25741504 | 8 |
| 9 | | | 68 | 192900 | 23454444 | 9 |
| 10 | | | | | | 10 |
| 11 | | | | | | 11 |
| 12 | | | | | | 12 |
| 13 | | | | | | 13 |
| 14 | | | | | | 14 |
| 15 | | | | | | 15 |
| 16 | | | | | | 16 |
| 17 | | | | | | 17 |
| 18 | | | | | | 18 |
| 19 | | | | | | 19 |
| 20 | | | | | | 20 |
| 21 | | | | | | 21 |
| 22 | | | | | | 22 |
| 23 | | | | | | 23 |
| 24 | | | | | | 24 |
| 25 | | | | | | 25 |
| 26 | | | | | | 26 |
| 27 | | | | | | 27 |
| 28 | | | | | | 28 |
| 29 | | | | | | 29 |
| 30 | | | | | | 30 |
| 31 | | | | | | 31 |
| 32 | | | | | | 32 |
| 33 | | | | | | 33 |
| 34 | | | | | | 34 |
| 35 | | | | | | 35 |
| 36 | | | | | | 36 |
| 37 | | | | | | 37 |
| 38 | | | | | | 38 |
| 39 | | | | | | 39 |
| 40 | | | | | | 40 |

Introduced: 4/7/75
Referred: Health, Education &
Social Services and Finance

1 IN THE HOUSE

BY FREEMAN AND GARDINER

2 HOUSE BILL NO. 386

3 IN THE LEGISLATURE OF THE STATE OF ALASKA

4 NINTH LEGISLATURE - FIRST SESSION

5 A BILL

6 For an Act entitled: "An Act relating to forgiveness of the remaining out-
7 standing school construction debt of the City of
8 Hydaburg; and providing for an effective date."

9 BE IT ENACTED BY THE LEGISLATURE OF THE STATE OF ALASKA:

10 * Section 1. Chapter 85, sec. 4, SLA 1963 is amended to read:

11 Sec. 4. Beginning July 1, 1963, the commissioner of education
12 shall pay annually to the general fund money to which the city becomes
13 entitled from cigarette tax receipts in the "School Fund" as provided
14 by the formula set out in sec. 125(c)(2), subchapter 14, Title 4,
15 Alaska Administrative Code, until the amount paid to the general fund
16 amounts to \$265,000 or until January 1, 1975, whichever occurs first.
17 No money from this source shall be paid to the city until the required
18 payment to the general fund has been made or until the payment termina-
19 tion date of January 1, 1975 has occurred.

20 * Sec. 2. This Act is retroactive to January 1, 1975.

21 * Sec. 3. This Act takes effect immediately in accordance with AS 01.10.-

22 070(c).
23
24
25
26
27
28
29

FISCAL NOTE

I. REQUEST
 Bill/Resolution No. HB 186
 Title Relating to foregiveness of the remaining outstanding school construction debt
~~XXXXXX~~ of the City of Hydaburg Date February 17, 1977

Requested by House Judiciary Committee

II. FISCAL DETAIL
 Agency Affected Education
 Program Category Affected Education
 Budget Request Unit(s) Affected Tobacco Tax

EXPENDITURES (Thousands of Dollars)

| | FY 77 | FY 78 | FY 79 | FY 80 | FY 81 | FY 82 |
|--------------------------|----------------|--------------|-------|-------|-------|-------|
| 100 PERSONAL SERVICES | | | | | | |
| 200 TRAVEL | | | | | | |
| 300 CONTRACTUAL | | | | | | |
| 400 COMMODITIES | | | | | | |
| 500 EQUIPMENT | | | | | | |
| 600 LAND & STRUCTURES | | | | | | |
| 700 GRANTS, CLAIMS, ETC. | 189,221 | - 0 - | | | | |
| TOTAL | 189,221 | - 0 - | | | | |

FUNDING (Thousands of Dollars)

| | | | | | | |
|-----------------|---------|-------|--|--|--|--|
| GENERAL FUND | 189,221 | - 0 - | | | | |
| FEDERAL FUNDS | | | | | | |
| OTHER (Specify) | | | | | | |

POSITIONS

| | | | | | | |
|-----------|--|--|--|--|--|--|
| FULL TIME | | | | | | |
| PART TIME | | | | | | |
| TEMPORARY | | | | | | |

III. ANALYSIS (See Fiscal Note Preparation Instructions, Section III)

See Attached

IV. DATE February 17, 1977 PREPARED BY  William D. Thomson, Dir. Mgt. Law & Finance
 AGENCY Education
 Original: Legislative Finance PHONE 465-2802
 cc: Budget and Management
 Prime Sponsor (First Legislator Named)

TO: [

October 66, BIA 1963

DATE : November 4, 1971

FROM:

SUBJECT: [unclear] to the State

BOARD OF HYDABURG CITY SCHOOL DISTRICT -
SCHOOL CONSTRUCTION DEBT

294,000.00

FINAL ACCOUNTING - TOTAL COST OF PROJECT Per State Dept. of Buildings - 224,450.00

less: District Payments and State Tobacco Tax Allowments as applied - 15,232.00

Unpaid Debt Balance as of 1/31/67 - 209,218.00

AV-002210 12/15/67 Transfer of 1967-68 Tobacco Tax entitlement to debt Unpaid Balance - 1,927.00

AV-001130 10/9/66 Transfer of 1967-68 Tobacco Tax entitlement to debt Unpaid Balance - 1,500.00

AV-001130 10/9/66 Transfer of 1967-68 Tobacco Tax entitlement to their debt to the State - 1,500.00

Unpaid Balance - 3,227.00

AV 05-009 11/1/70 (AV-2236 dated 11-11-70) Transfer of 1970-71 Tobacco Tax entitlement to the Hydaburg debt to the State. - 1,222.00

Unpaid Balance as of 11/3/70 - 222,267.00

AV 05-0084 11/4/71 transfer of 1971-72 Cigarette Tax entitlement to the Hydaburg debt to the State - 4,423.00

Unpaid Balance as of 11/4/71 - 217,844.00

AV 05-05-353 11/22/72 transfer of 1972-73 Cigarette Tax entitlement to the Hydaburg debt to the State - 4,595.00

Unpaid Balance as of 11/22/72 - 213,249.00

AV 05-0068 11/14/73 transf. of 1973-74 Cig. Tax entitlement to the Hydaburg debt to the State - 4,854.00

Unpaid balance as of 11/14/73 - 208,395.00

AV-05-0067 12/2/74 transf. of 1974-75 Cig. Tax entitlement to the Hydaburg debt to the State - 5,006.00

Unpaid balance as of 12-2-74 - 203,389.00

AV-05-FP-0190 12/17/75 transf. of 1975,76 Cig Tax Entitlement to the Hydaburg debt to the State - 5,338.00

Unpaid balance as of - 198,051.00

AV-05-0261 - 2.16/77 transf. of 1976-77 Cig Tax Entitlement to the Hydaburg debt to the State - 7,770.00

Unpaid balance - 189,221.00

Annual Debt Service City and Borough Districts
on Bonds issued prior to 7-1-76 payable after 7-1-77

| COLUMN WRITE IN | 1 2 3 4 5 6 7 8 9 10 11 | | | | | | | | | | | |
|--------------------|-------------------------|----------|----------|----------|----------|----------|---------|---------|---------|---------|---------|---------|
| | 1977 | 1978 | 1979 | 1980 | 1981 | 1982 | 1983 | 1984 | 1985 | 1986 | 1987 | |
| 1 | Anchorage | 6322398 | 11932337 | 11794935 | 11008061 | 10570991 | 9892108 | 9783673 | 9097062 | 9068395 | 8175398 | 8069798 |
| 2 | Bristol Bay | 59900 | 88400 | 85400 | 87250 | 83950 | 85500 | 81900 | 83150 | 79250 | 75350 | 76300 |
| 3 | Cordova | 43400 | 47200 | 45700 | 49200 | 47400 | 45600 | 48800 | 46700 | 44600 | 47250 | 45100 |
| 4 | Hillingham | none | | | | | | | | | | |
| 5 | Jain Banks | 1084030* | 1030835 | 784660 | 734442 | 679638 | 556350 | 550000 | 594000 | | | |
| 6 | Kainas | 29249 | 97098 | 94297 | 91498 | 93522 | 90373 | 92172 | 95760 | 90185 | 91442 | 95352 |
| 7 | Koonak | none | | | | | | | | | | |
| 8 | Kunau | 347262 | 761375 | 647697 | 612719 | 560897 | 518020 | 505781 | 336433 | 339292 | 336165 | 337592 |
| 9 | Kake | none | | | | | | | | | | |
| 10 | Kenai | 1012693 | 1130278 | 1116003 | 1110596 | 1088665 | 1165796 | 1151215 | 1049928 | 1020658 | 1005322 | 977620 |
| 11 | Ketchikan | 684934* | 682333 | 601757 | 603752 | 520707 | 525370 | 523845 | 526133 | | | |
| 12 | Klawock | none | | | | | | | | | | |
| 13 | Kodiak | 383068 | 442417 | 440318 | 439252 | 432443 | 425140 | 423383 | 444302 | 444393 | 418477 | 417852 |
| 14 | Mat-Su | 248156 | 1039915 | 1105521 | 1067625 | 1125650 | 989150 | 853275 | 533350 | 552800 | 531900 | 510800 |
| 15 | Nesuna | 7590 | 21000 | 21600 | 21190 | 21740 | 21260 | 20780 | 21270 | 21700 | 21100 | 21470 |
| 16 | Nome | none | | | | | | | | | | |
| 17 | North Slope | none | | | | | | | | | | |
| 18 | Petersburg | 101775 | 134200 | 129550 | 129900 | 134950 | 134350 | 128450 | 132550 | 101000 | 106200 | 109800 |
| 19 | St. Marys | none | | | | | | | | | | |
| 20 | Selawik | 72012 | | | | | | | | | | |
| 21 | Sitka | 192168 | 407671 | 409342 | 412760 | 408043 | 348904 | 357586 | 357866 | 359532 | 360682 | 350880 |
| 22 | Skagway | 26784 | 29203 | 31363 | 33264 | 34906 | 32832 | 34214 | 11146 | | | |
| 23 | Unalakleet | none | | | | | | | | | | |
| 24 | Valdez | none | | | | | | | | | | |
| 25 | Wrangell | 16237 | 16650 | 15825 | | | | | | | | |
| 26 | Zakutai | n.d. | | | | | | | | | | |
| 27 | | | | | | | | | | | | |
| 28 | | | | | | | | | | | | |
| 29 | | | | | | | | | | | | |
| 30 | | | | | | | | | | | | |

* Kenai is such that payments after 7-1-77 are not available.

Prepared By: _____
 Approved By: _____
 Initials: _____ Date: _____

Prepared By: _____
 Approved By: _____
 Initials: _____ Date: _____

| 12 | 13 | 6 | 7 | 8 | 9 | 10 | 11 | 12 | 13 | 1 | 2 | 3 |
|---------|---------|---------|---------|---------|--------|--------|-------|-------|-------|-------|------|------|
| 1988 | 1989 | 1990 | 1991 | 1992 | 1993 | 1994 | 1995 | 1996 | 1997 | 1998 | 1999 | 2000 |
| 7767265 | 7753880 | 6586525 | 6404998 | 5972223 | 551350 | | | | | | | |
| 74200 | | | | | | | | | | | | |
| 47655 | | | | | | | | | | | | |
| 88230 | 28507 | 82650 | 83437 | 87869 | | | | | | | | |
| 33213 | 333003 | 326948 | 324963 | 322416 | 96025 | 41200 | | | | | | |
| 992370 | 959295 | 348645 | | | | | | | | | | |
| 331042 | 360917 | 350900 | 362742 | 350280 | | | | | | | | |
| 489601 | 467600 | 445500 | 422800 | 205760 | | | | | | | | |
| 20870 | 21120 | 21370 | 21560 | 21690 | 20790 | 20800 | 20870 | 20820 | 20710 | 19570 | | |
| 95400 | | | | | | | | | | | | |
| 329786 | 367049 | 368266 | 130434 | 128882 | 129360 | 127061 | | | | | | |

TENTH LEGISLATURE

FISCAL NOTE

I. REQUEST

Bill/Resolution No. HB 186
Title Relating to forgiveness of the remaining outstanding school construction debt
~~XXXXXXXXXX~~ of the City of Hydaburg Date February 17, 1977

Requested by House Judiciary Committee

II. FISCAL DETAIL

Agency Affected Education
Program Category Affected Education
Budget Request Unit(s) Affected Tobacco Tax

EXPENDITURES (Thousands of Dollars)

| | FY 77 | FY 78 | FY 79 | FY 80 | FY 81 | FY 82 |
|--------------------------|---------|-------|-------|-------|-------|-------|
| 100 PERSONAL SERVICES | | | | | | |
| 200 TRAVEL | | | | | | |
| 300 CONTRACTUAL | | | | | | |
| 400 COMMODITIES | | | | | | |
| 500 EQUIPMENT | | | | | | |
| 600 LAND & STRUCTURES | | | | | | |
| 700 GRANTS, CLAIMS, ETC. | 189,221 | - 0 - | | | | |
| TOTAL | 189,221 | - 0 - | | | | |

FUNDING (Thousands of Dollars)

| | | | | | | |
|-----------------|---------|-------|--|--|--|--|
| GENERAL FUND | 189,221 | - 0 - | | | | |
| FEDERAL FUNDS | | | | | | |
| OTHER (Specify) | | | | | | |

POSITIONS

| | | | | | | |
|-----------|--|--|--|--|--|--|
| FULL TIME | | | | | | |
| PART TIME | | | | | | |
| TEMPORARY | | | | | | |

III. ANALYSIS (See Fiscal Note Preparation Instructions, Section III)

~~See Attached~~

IV. DATE February 17, 1977

PREPARED BY William D. Thomson, Dir. Mgt., Law & Finance
AGENCY Education
PHONE 465-2802

Original: Legislative Finance
cc: Budget and Management
Prime Sponsor (First Legislator Named)

Original sponsor: Osterback

Offered: 3/23/77
Referred: Rules

1 IN THE HOUSE

BY THE FINANCE COMMITTEE

2 SENATE CS FOR CS FOR HOUSE BILL NO. 189
3 IN THE LEGISLATURE OF THE STATE OF ALASKA

4 TENTH LEGISLATURE - FIRST SESSION

5 A BILL

6 For an Act entitled: "An Act making miscellaneous special appropriations to
7 state agencies and the University of Alaska; and
8 providing for an effective date."

9 BE IT ENACTED BY THE LEGISLATURE OF THE STATE OF ALASKA:

10 * Section 1. The sum of \$10,746,100 is appropriated from the general fund
11 to the following state entities for miscellaneous costs as specified:

12 (1) Department of Public Works

13 *Ch 248 of 76* Cold Bay dock *\$2,000,000 bonds passed* \$ 500,000
14 ? Upper Railbelt REAA 400,000
15 ? Point Hope National Guard Armory
16 relocation 25,000
17 ? Napakiak - direct grant, dredging 25,000
18 ? Napaskiak - direct grant, dredging 25,000
19 ? Akiachak - direct grant, dredging 25,000

20 (2) Department of Highways

21 ? Shagaluk Road 150,000
22 *Ch 279 of 76* Old Seward Highway *\$260,000 veto* 260,000
23 *Ch 279 of 76* Coronado Road - Eagle River *\$30,000 veto* 30,000
24 *Ch 279 of 76* Hutter Road, Slaughter House Access -
25 Homer *\$40,000 veto* 40,000
26 *Ch 279 of 76* McClay Road improvements - Homer *\$40,000 veto* 40,000
27 *ch 279 of 76* Bradley Road - Talkeetna *\$20,000 veto* 20,000
28 *ch 279 of 76* Whittier winter transportation shuttle *\$50,000 veto* 50,000
29 *ch 279 of 76* Spenard - seal coating roads *Spenard work in last year's budget (veto) and this year.* 300,000

1 (3) Department of Health and Social Services

| | | | | | |
|---|--------------|---|-------------------|-------------|-----------------------------|
| 2 | Ch 270 of 76 | Juvenile Unit - Fairbanks | \$2,000,000 bonds | \$2,000,000 | } Bond issue failed to pass |
| 3 | Ch 270 of 76 | Womens and Juvenile Facility - Juneau | \$1,500,000 bonds | 1,500,000 | |
| 4 | | Kiujylingoh Health Clinic - direct grant | | 100,000 | |
| 5 | | Kuskokwim Alcoholic Center | | 187,500 | |
| 6 | | YKHC - ear surgery funding | | 50,000 | |
| 7 | | Senior Citizen Facility - Fairbanks | | 500,000 | |
| 8 | | Tok Health Clinic - unit addition, direct | | | |
| 9 | | grant | | 75,000 | |

| | | | | | |
|----|--------------|--|----------------|--------|---------------|
| 10 | Ch 279 of 76 | Mt. Village Clinic - direct grant | \$100,000 veto | 50,000 | |
| 11 | Ch 279 of 76 | Unalaska Health Clinic - direct grant | \$50,000 | 50,000 | veto |
| 12 | Ch 279 of 76 | Ft. Yukon Health Clinic - direct grant | \$75,000 | 75,000 | veto \$75,000 |

13 (4) University of Alaska

| | | | | | |
|----|--------------|---|----------------------|---------|-----------------------------|
| 14 | Ch 243 of 76 | Physical education completion - Anchorage | \$900,000 bonds | 900,000 | } Bond issue failed to pass |
| 15 | | ? Anchorage Consortium Library Media | | | |
| 16 | | Services | | 282,900 | |
| 17 | Ch 243 of 76 | Anchorage Consortium Library books | \$250,000 bonds | 250,000 | |
| 18 | Ch 243 of 76 | Ketchikan Community College - Ziegler | | | |
| 19 | | Building improvements | \$99,000 bonds | 99,000 | |
| 20 | Ch 243 of 76 | Ketchikan Community College Career | | | |
| 21 | | Building remodeling | \$250,000 bonds veto | 250,000 | |

22 (5) Office of Telecommunications - Public Broadcasting

| | | | | | |
|----|--------------|---|---------------|---------|--|
| 23 | Ch 279 of 76 | Kotzebue Radio Equipment | \$15,000 veto | 15,000 | |
| 24 | Ch 279 of 76 | Noorvik, Kiana, Kivilina mini TV equip- | | | |
| 25 | | ment - community grant | \$15,000 veto | 15,000 | |
| 26 | | ? KYUK cable hook-up | | 20,000 | |
| 27 | Ch 279 of 76 | Kodiak mini TV | \$20,000 veto | 20,000 | |
| 28 | | ? Public Broadcasting Center | | 300,000 | |

29 (6) Department of Fish and Game

| | | |
|----|---|-----------|
| 1 | ? Yukon Area Sheefish Resource Survey | \$ 25,200 |
| 2 | ? Kobuk - Selawik Sheepfish Resource | |
| 3 | Survey | 52,500 |
| 4 | ? AYK Herring Study (Commercial Fisheries | |
| 5 | Division) | 22,000 |
| 6 | ? Norton Sound - Kotzebue Sound Salmon | |
| 7 | Escapement Studies | 30,000 |
| 8 | ? Kotzebue Chum Salmon Forecast Studies | 42,000 |
| 9 | ? Yukon Chum Salmon Forecast Studies | 42,000 |
| 10 | ? Advisory Fish and Game Boards | 161,000 |
| 11 | (7) Department of Natural Resources | |
| 12 | <i>Ch 279 of 76</i> Northwest Area Range and Soil Survey | |
| 13 | (Agriculture) <i>\$50,000 veto \$25,000</i> | 17,000 |
| 14 | ? Halibut Point Recreational Area - Sitka | 90,000 |
| 15 | <i>Ch 279 of 76</i> Rifle Range - Sitka <i>\$25,000 veto</i> | 25,000 |
| 16 | (8) Community and Regional Affairs | |
| 17 | <i>Ch 279 of 76</i> Fire truck - Galena - direct grant <i>\$25,000 veto</i> | 25,000 |
| 18 | ? Fire Department renovation - Tok - direct | |
| 19 | grant | 25,000 |
| 20 | Day Care Assistance | 250,000 |
| 21 | Kodiak | \$ 25,000 |
| 22 | Fairbanks | 111,000 |
| 23 | Anchorage | 80,000 |
| 24 | Juneau | 34,000 |
| 25 | ? D-6 Cat - Kipnak - direct grant | 55,000 |
| 26 | (9) Department of Education | |
| 27 | ? Library Division: Russian Orthodox Church | |
| 28 | record microfilming | 30,000 |
| 29 | Community Schools | 1,225,000 |



Alaska State Legislature
House

HOUSE RESOURCES COMMITTEE

Alvin Osterback, Chairman

Pouch V, State Capitol
Juneau, Alaska 99811
(907) 465-3715

25 March 1977

Jay Hogan, Director
Legislative Finance Division
Pouch WF
Juneau, AK 99811

Dear Jay,

I need an analysis of SCSHB 189 by late Monday or early Tuesday. I want an analysis of each item, specifically:

1. Did the project appear in any appropriation bill to pass the 9th Legislature? If so, which bill, and was it vetoed?
2. Does the item appear in the Governor's FY 1978 budget request?
3. What budget data exists on each item? Please supply this to me.
 - a. explanation of project.
 - b. justification of project.
 - c. copies of files or backup material that would be useful in determining justification for the appropriation.

Some of this may appear in the Governor's Budget presentation or in the portion that was deleted by the Governor's Budget Review Committee.

The bill may go to Free Conference, so this is an urgent matter.

Thank you for your cooperation.

Sincerely,

A handwritten signature in cursive script that reads "Alvin Osterback".

Alvin Osterback, Chairman
House Resources Committee

AO:jn

"An Act making a special appropriation to the Department of Public Works for construction of a new dock at Cold Bay; and providing for an effective date."

COMMITTEE REPORT

HOUSE

2-8-77

2-10-77

Date

Mr. Speaker:

The Committee on FINANCE has had HB 189

under consideration. A majority of the members of the Committee

- recommends it do pass
- recommends it do not pass
- recommends it do pass with attached amendment(s)
- recommends it be replaced with CS for HB 189 and that CS for HR 189 do pass
- (and) recommends it be referred to the _____ committee
- reports it back without recommendation
- AND attaches a report of its intent
- (other) _____

MEMBERS SIGNING THE MAJORITY REPORT:

| | | |
|-------|-------|-------|
| _____ | _____ | _____ |
| _____ | _____ | _____ |
| _____ | _____ | _____ |
| _____ | _____ | _____ |

MEMBERS NOT CONCURRING IN THE MAJORITY REPORT:

_____ recommends: _____

_____ recommends: _____

_____ recommends: _____

Chairman

Original sponsor: Osterback

1
2
3
4
5
6
7
8
9
10
11
12
13
14
15
16
17
18
19
20
21
22
23
24
25
26
27
28
29

IN THE HOUSE

BY THE FINANCE COMMITTEE

CS FOR HOUSE BILL NO. 189

IN THE LEGISLATURE OF THE STATE OF ALASKA

TENTH LEGISLATURE - FIRST SESSION

A BILL

For an Act entitled: "An Act making a special appropriation to the Department of Public Works for construction of a new dock at Cold Bay; and providing for an effective date."

BE IT ENACTED BY THE LEGISLATURE OF THE STATE OF ALASKA:

* Section 1. The sum of \$500,000 is appropriated from the general fund to the Department of Public Works, division of waters and harbors, for the costs of removing the old dock at Cold Bay and constructing a new one in its place.

* Sec. 2. This Act takes effect immediately in accordance with AS 01.10.-070(c).



Alaska State Legislature

JUNEAU ALASKA

M E M O R A N D U M

8 February 1977

SUBJECT: Cold Bay Dock
Summary of February 4, 1977
meeting with Division of
Aviation in Anchorage

TO: Representative Steve Cowper
Chairman, House Finance Comm.

FROM: Representative Al Osterback

People present at the meeting were:

DIVISION OF AVIATION

CHEVRON, U.S.A.

Harry Shawback, Director

Bill Hueners

Jim Rhode

Dan Urbach

Al French

N. F. Schoenstein

J. H. Howard

H. R. Coward

W. C. Wynn

Alvin Osterback, Representative

Kay Poland, Senator

George Silides, Research Assistant to House Resources
and Senate Resources Committees

Buel Hixson, Professional Engineer, Division of
Waters and Harbors, Juneau

Commander L. D. Gordon, U.S. Coast Guard, Anchorage

D. E. Shaw, Flying Tigers

Robert L. Hanson, Reeves Aleutian

All interested parties present agreed that the design proposed by Buel Hixson, Division of Waters & Harbors was the absolute minimum facility for everyone's use.

The present facility is beyond repair, i.e. repair would not be economically feasible. It is a wood facility, subject to severe lateral ice flow. The proposed steel & concrete facility would withstand this ice if annual maintenance is done. The proposed facility is needed now, since the present facility is not really strong enough to hold a vehicle. There has already been one death due to the condition of the dock.

The dock's primary function is to deliver fuel (Chevron, U.S.A.) for the Airport and local uses. It is also used for delivering supplies to the Cold Bay residents.

MEMORANDUM: Cold Bay Dock
8 February 1977

Other parties have conveyed an interest in the dock as follows:

1. Consul General H. A. Djurhuus
Royal Danish Consulate General

The Consul General was in Juneau in January. He discussed the possibility of Denmark processing bottom fish (fish that we don't even use yet) in the Aleutian Chain, transporting them to Cold Bay by boat and then flying them to the Orient, Hawaii and Europe. They discussed the possible use of planes as large as 747's. Cold Bay is the only airport in the Aleutian Chain large enough to handle an operation such as this.

This type of operation would require more than the minimum dock proposed at this time, perhaps a double tressle dock. The proposed design does, however, allow for expansion on the causeway. You could add one more lane by simply installing one more row of steel piling and a lane of the prefab concrete decking.

2. Peter Pan Seafoods, Inc.
Seattle, WA *times*
3. Major airlines have inferred at various *times* that they would like to use Cold Bay for great circle routes instead of Anchorage if there were enough fuel.
4. Sealand *now* goes into every little harbor on the Chain. They have said that they would prefer to take a large ship to Cold Bay and let the Alaska Marine Highway System shuttle the freight within the Aleutian ports.
5. George Silides said that he has given the area considerable study and that there is a larger coastal trade developing with Cold Bay as the focal point.

Page 3
MEMORANDUM: Cold Bay Dock
8 February 1977

Summary of Design

Construction Style: Concrete/Steel tressle, one lane designed to handle H-20 loading. This will be strong enough for vans.

1. Causeway (approach) - 1800 ft.
 - a. 75 steel pilings on 24' centers.
 - b. Concrete prefabricated decking.
 - c. Two turnouts with ladders for 50' to 100' fishing vessels.
2. Dock - 40' X 105' at 30' water depth.
3. Four breasting dolphins.
4. Catwalks

The Engineer's estimate on this structure is \$2.5 million.

This estimate does not include the removal of the pipeline from the old dock and replacement at the new dock site. Chevron said that they would do that, but that the costs would be passed on to the consumers through fuel costs.



Alaska State Legislature

POUCH Y, STATE CAPITOL
JUNEAU, ALASKA 99811
907 465-3800

MEMORANDUM

3 February 1977

SUBJECT: Cold Bay Dock
TO: Division of Aviation
FROM: Alvin Osterback
Representative, District 15

On February 2, 1977 I talked with Don Statter about the Cold Bay Dock. The following is what I learned:

1. \$2 million in aviation funds has been appropriated for the Cold Bay Dock.
2. It would take \$2.5 million to build a minimum dock.
 - a. It would take \$3 million dollars for an adequate dock.
 - b. As a rule of thumb, (dollar per size ratio) it would take \$.5 million for a 50' X 200' (10,000 sq. ft.) addition.
3. Construction style: Concrete/steel tressle structure
 - a. Steel piling
 - b. Prefabricated concrete decking
 - c. Dock with dolphins
 - d. Pipeline for fuel - should go to 30' depth to accomodate tankers.
 - e. One vehicle access with room to turn around on the end of the dock -- probably designed for H-20 loading (same as highway loading).
4. A member of Don Statter's staff was working on the design for a minimum dock, but it is at a temporary standstill due to that staff member's broken ankle.

Page 2
MEMORANDUM: Cold Bay Dock
3 February 1977

Parties interested in the dock:

1. Lloyd Guffy (206) 624-4344
Peter Pan Seafoods, Inc.
1220 Dexter Horton Bldg.
Seattle, WA 98104
2. Consul General H. A. Djurhuus
Royal Danish Consulate General
3440 Wilshire Blvd.
Los Angeles, CA 90010

The Consul General General from Denmark was here a few weeks ago. I talked with him in Juneau. The Danish are interested in harvesting bottom fish in the Aleutian Chain, transporting them to Cold Bay by boat, and then flying them (Flying Tiger, etc.) to the Orient, Hawaii and Europe. They discussed the possible use of planes as large as 747's.

This type of operation would need more than a minimum dock. Don Statter suggested such an operation may need a 2 lane tressle.

I will be serving on a fact finding delegation to investigate the possibilities of a joint venture in the fishing industry between Denmark and Alaska.

AO:jn

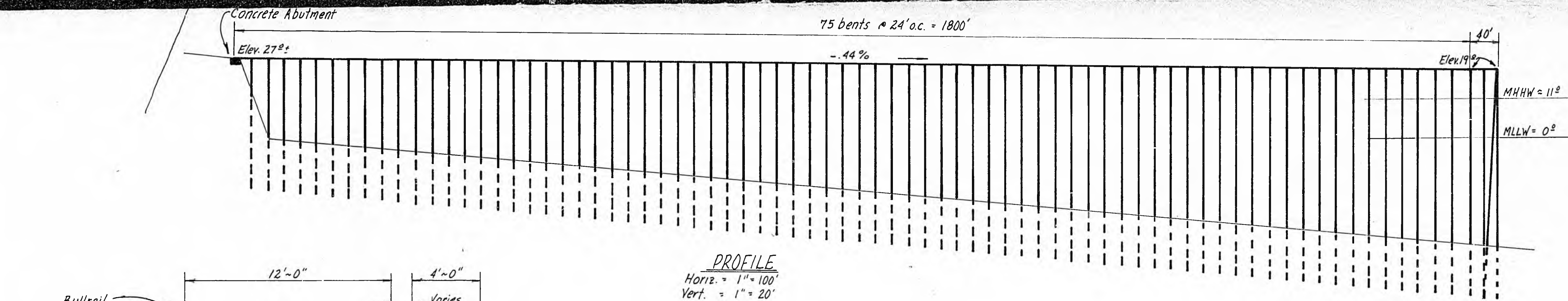

PROFILE
 Horiz. = 1" = 100'
 Vert. = 1" = 20'

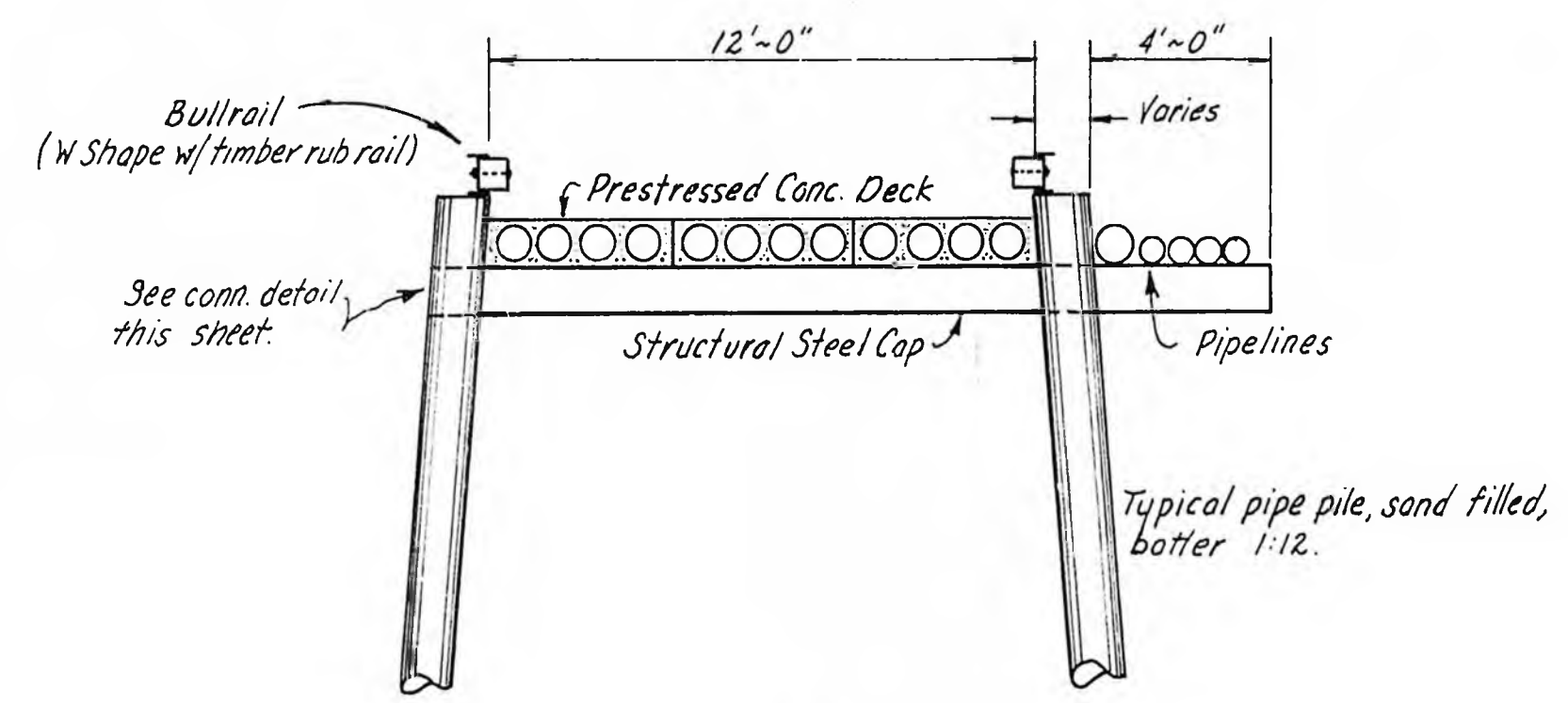

APPROACH SECTION A-A
 1/4" = 1'-0"

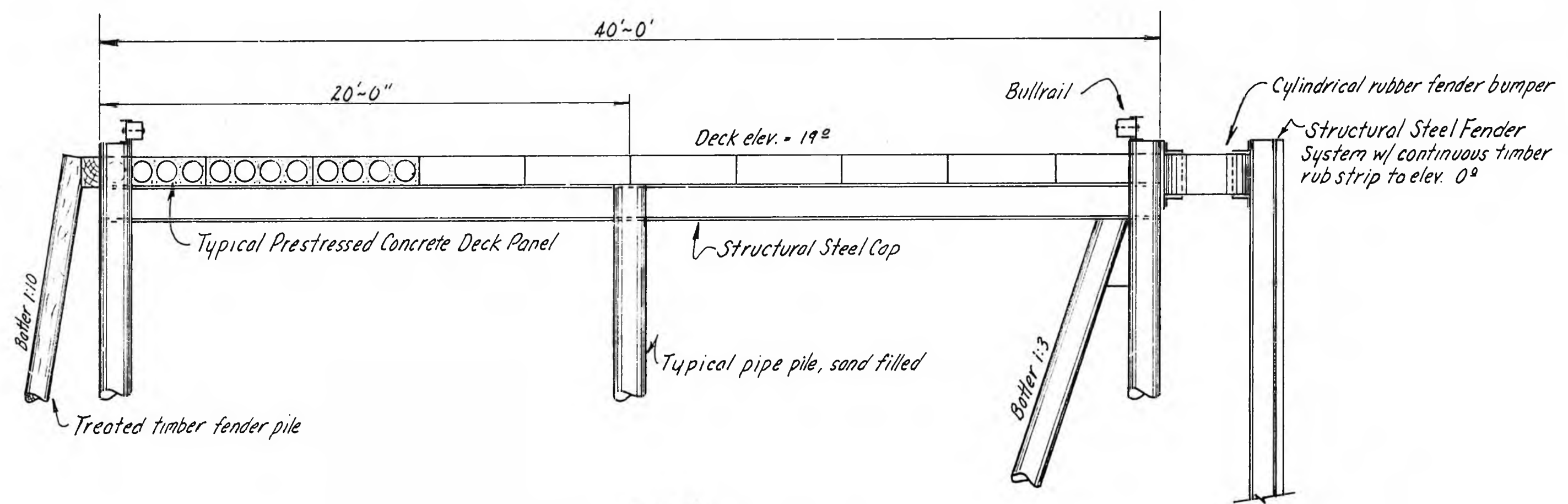

DOCK SECTION B-B
 1/4" = 1'-0"

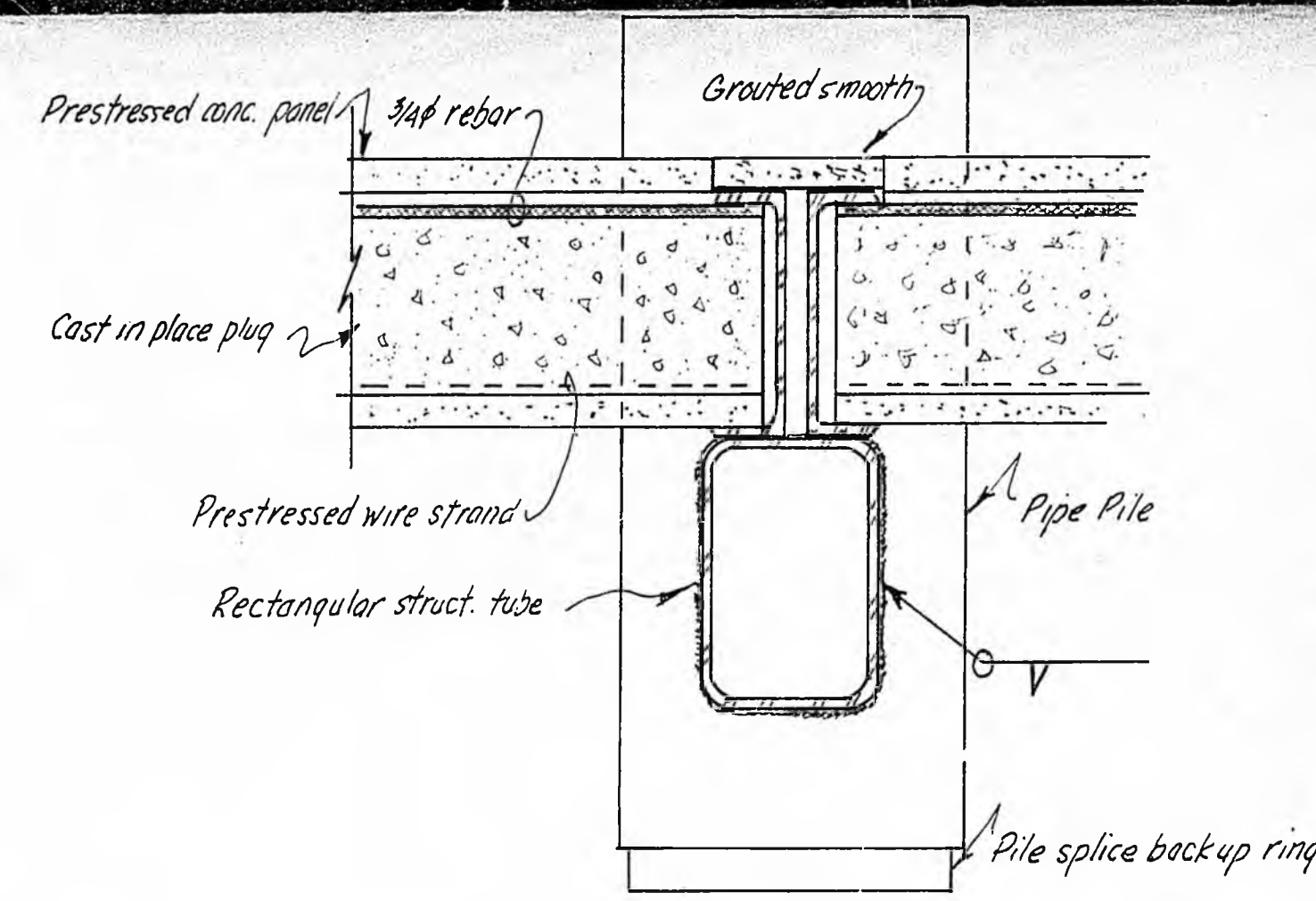

CONNECTION DETAIL
 1 1/2" = 1'-0"

DO NOT SCALE THIS DRAWING - USE DIMENSIONS
 STATE OF ALASKA
 DEPARTMENT OF PUBLIC WORKS
 DIVISION OF WATER AND HARBORS

COLD BAY PORT FACILITIES
Preliminary

| | | |
|-----------------------|--------------------|----------------|
| SCALE <i>As noted</i> | SURVEYED _____ | APPROVED _____ |
| DESIGNED _____ | DRAWN <i>TAL</i> | DIRECTOR _____ |
| CHECKED _____ | DATE <i>2/3/77</i> | |
| PROJECT NUMBER _____ | SHEET _____ | OF _____ |

Introduced: 2/8/77
Referred: Finance

1 IN THE HOUSE

BY OSTERBACK

2 HOUSE BILL NO. 189

3 IN THE LEGISLATURE OF THE STATE OF ALASKA

4 TENTH LEGISLATURE - FIRST SESSION

5 A BILL

6 For an Act entitled: "An Act making a special appropriation to the Depart-
7 ment of Public Works for construction of a new dock at
8 Cold Bay; and providing for an effective date."

9 BE IT ENACTED BY THE LEGISLATURE OF THE STATE OF ALASKA:

10 * Section 1. The sum of \$500,000 is appropriated from the general fund to
11 the Department of Public Works, division of waters and harbors, for the costs
12 of removing the old dock at Cold Bay and constructing a new one in its place.

13 * Sec. 2. This Act takes effect July 1, 1977.

14

15

16

17

18

19

20

21

22

23

24

25

26

27

28

29

#



Alaska State Legislature

File copy

March 28, 1977

POUCH Y, STATE CAPITOL
JUNEAU, ALASKA 99811
907 465-3800

MEMORANDUM

TO: Representative Alvin Osterback
Chairman, House Resources Committee

FROM: *J.H.H.* J. H. Hogan, Director
Legislative Finance Division

SUBJECT: Analysis of SCSHB 189

As I mentioned to you on the phone, most of the items added in SCSHB 189 are items added by the Legislature to last year's General Appropriations Act or various bond issues. On most of these items we have no information in our files.

I have taken the committee substitute and adjacent to each item in the bill have added the chapter number and previous amount for those items which have received previous appropriations. The items with question marks appearing before them are new items as far as we know. In those few cases where we have additional backup, that information is indexed in the right-hand column and attached at the rear.

JHH:pw

Attachments

Original sponsor: Osterback

Offered: 3/23/77
Referred: Rules

1 IN THE HOUSE

BY THE FINANCE COMMITTEE

2 SENATE CS FOR CS FOR HOUSE BILL NO. 189

3 IN THE LEGISLATURE OF THE STATE OF ALASKA

4 TENTH LEGISLATURE - FIRST SESSION

5 A BILL

6 For an Act entitled: "An Act making miscellaneous special appropriations to
7 state agencies and the University of Alaska; and
8 providing for an effective date."

9 BE IT ENACTED BY THE LEGISLATURE OF THE STATE OF ALASKA:

10 * Section 1. The sum of \$10,746,100 is appropriated from the general fund
11 to the following state entities for miscellaneous costs as specified:

ORIGINAL AMOUNTS/IF VETOED

| | | | |
|----|----------|---|-------------------------|
| 12 | (1) | Department of Public Works | |
| 13 | SLA 1976 | Cold Bay dock - \$2,000,000 bonds passed | \$ 500,000 |
| 14 | Ch. 248 | ? Upper Railbelt REAA | 400,000 |
| 15 | | ? Point Hope National Guard Armory | |
| 16 | | relocation | 25,000 |
| 17 | | ? Napakiak - direct grant, dredging | 25,000 |
| 18 | | ? Napaskiak - direct grant, dredging | 25,000 |
| 19 | | ? Akiaahak - direct grant, dredging | 25,000 |
| 20 | (2) | Department of Highways | |
| 21 | | ? Shagaluk Road | 150,000 |
| 22 | Ch. 279 | Old Seward Highway - \$260,000 veto | 260,000 |
| 23 | Ch. 279 | Coronado Road - Eagle River - \$30,000 veto | 30,000 |
| 24 | Ch. 279 | Hutter Road, Slaughter House Access - | |
| 25 | | Homer - \$40,000 veto | 40,000 |
| 26 | Ch. 279 | McClay Road improvements - Homer \$40,000 veto | 40,000 |
| 27 | Ch. 279 | Bradley Road - Talkeetna - \$20,000 veto | 20,000 |
| 28 | Ch. 279 | Whittier winter transportation shuttle | \$50,000 veto 50,000 |
| 29 | Ch. 279 | Spenard - seal coating roads - Spenard work in last year's budget (veto) and this years. | 300,000 |

| | | | | | | | |
|----|---------|--|----------------------------|-----------------|--|-----|-----|
| 1 | (3) | Department of Health and Social Services | | | | | |
| | | | | bonds | | | |
| 2 | Ch. 270 | Juvenile Unit - Fairbanks | -\$2,000,000 / \$2,000,000 | | } bond issue failed-"A" to pass | | |
| 3 | Ch. 270 | Womens and Juvenile Facility - Juneau / | 1,500,000 | | | | "B" |
| | | | -\$1,500,000 | bonds | | | |
| 4 | | Klujylingoh Health Clinic - direct grant | 100,000 | | | | |
| 5 | | Kuskokwim Alcoholic Center | 187,500 | | | | |
| 6 | | YKHC - ear surgery funding | 50,000 | | | | |
| 7 | HB 135 | Senior Citizen Facility - Fairbanks | 500,000 | | | "C" | |
| 8 | | Tok Health Clinic - unit addition, direct | | | | | |
| 9 | | grant | 75,000 | | | | |
| 10 | Ch. 279 | Mt. Village Clinic - direct grant / | \$100,000 | veto | | | |
| | | | 50,000 | | | | |
| 11 | Ch. 279 | Unalaska Health Clinic - direct grant / | \$50,000 | veto | | | |
| | | | 50,000 | | | | |
| 12 | Ch. 279 | Ft. Yukon Health Clinic - direct grant / | \$200,000 | veto \$75,000 | | | |
| | | | 75,000 | | | | |
| 13 | (4) | University of Alaska | | | | | |
| | | | | \$600,000 bonds | | | |
| 14 | Ch. 243 | Physical education completion - Anchorage / | 900,000 | | | "D" | |
| 15 | | ? Anchorage Consortium Library Media | | | | | |
| 16 | | Services | 282,900 | | | | |
| | | | bonds | | | | |
| 17 | Ch. 243 | Anchorage Consortium Library books / | \$140,000 | 250,000 | } BOND ISSUE ----"E" FAILED TO PASS | | |
| 18 | Ch. 243 | Ketchikan Community College - Ziegler | | | | | |
| 19 | | Building improvements - \$90,000 bonds | 99,000 | | | | "F" |
| 20 | Ch. 243 | Ketchikan Community College Career | | | | | |
| 21 | | Building remodeling - \$500,000 bonds veto | 250,000 | | | "G" | |
| 22 | (5) | Office of Telecommunications - Public Broadcasting | | | | | |
| 23 | Ch. 279 | Kotzebue Radio Equipment - \$15,000 veto | 15,000 | | | | |
| 24 | Ch. 279 | Noorvik, Kiana, Kivilina mini TV equip- | | | | | |
| 25 | | ment - community grant - \$7,500 veto | 15,000 | | | | |
| 26 | | ? KYUK cable hook-up | 20,000 | | | | |
| 27 | Ch. 279 | Kodiak mini TV - \$18,400 veto | 20,000 | | | | |
| 28 | | ? Public Broadcasting Center | 300,000 | | | | |
| 29 | (6) | Department of Fish and Game | | | | | |

| | | | |
|----|---------|--|-------------------|
| 1 | ? | Yukon Area Sheefish Resource Survey | \$ 25,200 |
| 2 | ? | Kobuk - Selawik Sheepfish Resource | |
| 3 | | Survey | 52,500 |
| 4 | ? | AYK Herring Study (Commercial Fisheries | |
| 5 | | Division) | 22,000 |
| 6 | ? | Norton Sound - Kotzebue Sound Salmon | |
| 7 | | Escapement Studies | 30,000 |
| 8 | ? | Kotzebue Chum Salmon Forecast Studies | 42,000 |
| 9 | ? | Yukon Chum Salmon Forecast Studies | 42,000 |
| 10 | ? | Advisory Fish and Game Boards | 161,000 |
| 11 | (7) | Department of Natural Resources | |
| 12 | Ch. 279 | Northwest Area Range and Soil Survey | |
| 13 | | (Agriculture)-\$50,000 veto \$25,000 | 17,000 |
| 14 | ? | Halibut Point Recreational Area - Sitka | 90,000 |
| 15 | Ch. 279 | Rifle Range - Sitka - \$25,000 veto | 25,000 |
| 16 | (8) | Community and Regional Affairs | |
| 17 | Ch. 279 | Fire truck - Galena - direct grant / \$25,000 veto | 25,000 |
| 18 | ? | Fire Department renovation - Tok - direct | |
| 19 | | grant | 25,000 |
| 20 | HB 215 | Day Care Assistance | 250,000 ----- "H" |
| 21 | | Kodiak | \$ 25,000 |
| 22 | | Fairbanks | 111,000 |
| 23 | | Anchorage | 80,000 |
| 24 | | Juneau | 34,000 |
| 25 | ? | D-6 Cat - Kipnak - direct grant | 55,000 |
| 26 | (9) | Department of Education | |
| 27 | ? | Library Division: Russian Orthodox Church | |
| 28 | | record microfilming | 30,000 |
| 29 | | Community Schools | 1,225,000 |

HB 179

1 * Sec. 2. This Act takes effect immediately in accordance with AS 01.10.-
2 070(c).

3
4
5
6
7
8
9
10
11
12
13
14
15
16
17
18
19
20
21
22
23
24
25
26
27
28
29

Capital Budget Proposed Project

40

Form 26 MUST BE COMPLETED AND ATTACHED WITH EACH PROPOSED PROJECT REQUEST

| | | | |
|--|-----------------------|--|---------------------------------|
| TITLE Fairbanks Correction Center Juvenile Unit and Remodeling | | OPERATING BUDGET DRU Adult Confinement 06-65-01-01-04 | |
| PRIORITY 77-8 | STARTING DATE 3/77 | COMPLETION DATE 7/79 | TOTAL PROJECT COST 4,100,000 |
| LOCATION Fairbanks | | AREA SERVED Fairbanks Service Area | ELECTION DISTRICT 16 |
| SOURCE OF COST ESTIMATE Division of Buildings | | DATE OF ESTIMATE 8/75 | |

DESCRIPTION Convert the Fairbanks Correctional Center into a short term, minimum to maximum security institution serving local area intake and short-term detention for adults as its primary mission. Create a separate juvenile processing and detention facility

Convert part of the short-term dorm living area (one 24 bed dorm) into program space and construct a new wing of forty single bed cells to provide for short-term single cell housing.

- Construct a double security fence around the perimeter of the Center and pave roads.
- Install a fire protection system in kitchen area to prevailing code.
- Construct a separate Juvenile Processing and Detention Facility.

| PROJECT TYPE | | |
|-----------------------|---|-----------|
| BUILDING CONSTRUCTION | X | EQUIPMENT |
| OTHER IMPROVEMENT | | LAND |

| PROJECT PURPOSE | |
|---|-------------------------------------|
| Major Maintenance (Rehab) | <input type="checkbox"/> |
| Improvement of Services | <input type="checkbox"/> |
| Accommodation of Increased Demand | <input checked="" type="checkbox"/> |
| New Program or Service Accommodation | <input type="checkbox"/> |
| Supplement Previously Authorized Funds | <input type="checkbox"/> |
| Preliminary Feasibility or Cost Studies | <input type="checkbox"/> |
| Other | <input type="checkbox"/> |

| PROJECT EXPENDITURES | TOTAL | BUDGET YEAR | BUDGET YEAR PLUS 1 | BUDGET YEAR PLUS 2 | REMAINING COST |
|---|--------|-------------|--------------------|--------------------|----------------|
| TOTAL ANNUAL EXPENDITURE (Capital Cost) | 4100.0 | 457.0 | 1801.5 | 1841.5 | |
| PLANNING AND ENGINEERING | 342.0 | 114.0 | 114.0 | 114.0 | |
| LAND | 229.0 | 229.0 | | | |
| CONSTRUCTION | 2947.0 | | 1473.5 | 1473.0 | |
| EQUIPMENT | 240.0 | | 100.0 | 140.0 | |
| TRAINING AND OTHER | 342.0 | 114.0 | 114.0 | 114.0 | |

| OPERATIONAL COST AND NO. PERSONNEL INCREASE (DECREASE) | | ULTIMATE ANNUAL | BUDGET YEAR | BUDGET YEAR PLUS 1 | BUDGET YEAR PLUS 2 |
|--|--|-----------------|-------------|--------------------|--------------------|
| OTHER SOURCES | | | | | |
| GENERAL FUND | | 787.2 | | | |
| TOTAL ANNUAL OPERATIONAL COST | | | | | |
| POSITIONS FULL-TIME EQUIVALENTS | | 13 | | | |

Impact in FY80
300.0

| APPROPRIATION REQUEST | |
|--------------------------------|--------|
| Federal Receipts | |
| Required General Fund Matching | |
| Other General Fund | |
| G. O. Bonds | 4100.0 |
| ASHA Bonds | |
| Inter-Agency Transfers | |
| Other | |
| TOTAL | 4100.0 |

AGENCY H&SS Corrections PROGRAM Admin. of Justice PROJECT & PRIORITY NO Center Remodeling 77-8

25 CAPITAL BUDGET PROPOSED PROJECT



STATE OF ALABAMA
PUBLIC WORKS

PROJECT # _____
NAME AND LOCATION: Juvenile/Women's Unit, Juneau

REGION: Southeastern
E

Proj. No: _____

FUNDING: 76 Bonds \$ 1,500,000 (M/c: _____)
(Source) _____ \$ _____ (M/c: _____)
_____ \$ _____ (M/c: _____)
Total Funding \$ 1,500,000

| Date | Initials | Approved by: |
|------|----------|----------------------|
| | | Design Section |
| | | Construction Section |
| | | Fiscal Section |
| | | Director |
| | | Commissioner |
| | | Planning Agency |

Type of Facility: desired:
15 person capacity juveniles, 5 person capacity
women (about 11,000 sq. ft.)

| FINANCIAL INFORMATION: | Actv. Code | Planning Fund Budget Amount | Project Total Budget Amount | REMARKS |
|------------------------------|--------------|-----------------------------|-----------------------------|---|
| 0-LAND: | Total | \$ -0- | \$ | |
| Appraisals | 0A0 | | | land already owned by Dept. Health & Social Services |
| Acquisition | 0B0 | | | |
| Legal Expense | 0L0 | | | |
| Relocation | 0R0 | | | |
| Misc-Contingency | 0Z0 | | | |
| 1-SITE INVESTIGATION: | Total | 22,500 | 18,000 | boundary survey verification, 2' 4 test holes |
| Inspection | 1I0 | | | |
| Surveys | 1S0 | | | |
| Soils Information | 1T0 | | | |
| Misc-Contingency | 1Z0 | | | |
| 2-OTHER SERVICES: | Total | 6,280 | 3,890 | No program consultant required (previous study available) |
| Cost Control | 2E0 | 780 | 3,890 | |
| | | 5,500 | -0- | |
| Misc-Contingency | 2Z0 | | | |
| 3-DESIGN SERVICE: | Total | 22,500 | 98,700 | architect, mech., elec., struct'l. xerox, postage, travel, long distance |
| Fees 1% | 3F0 | | 84,000 | |
| | | | -0- | |
| Reimbursable Exp | 3R0 | | 10,000 | |
| Sub-Consultants | 3C0 | | -0- | |
| Misc-Contingency | 3Z0 | | 4,700 | |
| 4-ADMINISTRATION: | Total | 4,240 | 11,040 | LCCA, procurement procedures, info, poli |
| Departmental Admin | 4A0 | 3,340 | 6,190 | |
| Office Expense | 400 | | 100 | |
| Payroll | 4P0 | 900 | 4,200 | |
| Travel | 4T0 | | -0- | |
| Misc-Contingency | 4Z0 | | 550 | |
| 5-DESIGN SECTION: | Total | 8,000 | 54,814 | xerox, document printing, phone, po DM II (5 mos) m/c/c: 3 mos. clerical DM 2 trips draftsman: 2 mos. CM needs travel to Anch. |
| Office Expense | 500 | | 3,950 | |
| Payroll | 5P0 | | 40,834 | |
| Travel | 5T0 | | 490 | |
| Misc-Contingency | 5Z0 | | 3,560 | |
| 6-CONSTR SECTION: | Total | 750 | 61,975 | xerox, document printing, phone, po res. engr: 3 mos. staff engr.: 3 mos inspector 1/2 time: 5 mos. clerical: 6 mos. |
| Office Expense | 600 | | 4,640 | |
| Payroll | 6P0 | 750 | 52,175 | |
| Travel | 6T0 | | -0- | |
| Special Consultants | 6C0 | | -0- | |
| Claims & Disputes | 6D0 | | -0- | |
| Misc-Contingency | 6Z0 | | 5,160 | |
| 7-EQUIPMENT: | 7E0 | -0- | 60,000 | to be verified |
| 8-CONSTR CONTRACTS: | Total | -0- | 1,191,581 | |
| Construction, New (72004) | 8R0 | | 1,121,581 | |
| | | | | |
| | | | | |
| | | | | |
| Misc-Contingency | 6% 8Z0 | | 70,000 | categories 0 + 7 + 8 = 1,251,581 |
| SUB-TOTALS | | \$ | -0- | |
| RESTRICTED | | \$ | -0- | |
| CONTINGENCY | | \$ | -0- | |
| PROJECT TOTALS | | \$ 61,270 | 1,500,000 | |

REMARKS: SCHEDULE: Open Bids: _____ () NTP: _____
Contractor Completion: 11/3/76 Final Acceptance: _____ ()