

leg. Finance - House & Senate Finance Comte Files (1975-76) 383

SHB 225, HB 226, 227, 229, 231



RECORDS CERTIFICATION



I, the undersigned, an employee of the State of Alaska, do hereby certify that the microfilm images on this microform are accurate reproductions of the original records of the State of Alaska as accumulated during the regular course of business, and that it is the established policy and practice of this State to microfilm its records and to dispose of the original records after microfilm reproductions have been made.

James O. Smith
Signature of Camera Operator

1/31/90
Date

"An Act relating to the elimination of architectural barriers in public buildings and facilities for physically handicapped, aged or infirm persons; and providing for an effective date."

COMMITTEE REPORT

4/15/75

HOUSE

Mr. Speaker:

Date 4/19/75

The Committee on FINANCE has had SSHB 225

under consideration. A Majority of the members of the Committee

recommends it DO PASS

recommends it DO NOT PASS

recommends it DO PASS WITH ATTACHED AMENDMENT(S)

recommends it BE REPLACED WITH CS FOR FIN CS FOR SSB 225 AND THAT

FIN CS FOR SSB 225 DO PASS

"and" recommends it BE REFERRED TO THE _____

COMMITTEE

reports it back WITHOUT RECOMMENDATION

"other"

Members signing the Majority report:

<u>[Signature]</u>	<u>[Signature]</u>	_____
<u>[Signature]</u>	<u>[Signature]</u>	_____
<u>[Signature]</u>	_____	_____
<u>[Signature]</u>	_____	_____

Members NOT concurring in the Majority report:

_____ recommends:

_____ recommends:

_____ recommends:

_____ recommends:

_____ recommends:

[Signature] Chairman

THE LEGISLATURE OF THE STATE OF ALASKA
FISCAL NOTE
 Second Session - Ninth Legislature

I. REQUEST

Bill No. SB 201 or SSHB 225
 Title: Relating to architectural barriers in public places & facilities
 Requested by: House Finance Committee Date: 19 April 1975
 Return Date Requested: _____ Date: 28 May 1976
 Agency: Department of Public Works Program: _____

II. FISCAL DETAIL

Budget Request Unit(s) Affected: _____

A. EXPENDITURES: (Thousands of dollars)

OBJECT	FY 76	FY 77	FY 78	FY 79	FY 80	FY 81
100 PERSONAL SERVICES	-0-	0	0			
200 TRAVEL						
300 CONTRACTUAL						
400 COMMODITIES						
500 EQUIPMENT						
600 LAND & STRUCTURES						
700 GRANTS, CLAIMS, ETC.						
TOTAL	-0-	-0-	-0-			

B. FUNDING: (Thousands of dollars) NONE

GENERAL FUND						
FEDERAL FUNDS						
OTHER						

C. POSITIONS: N/A

PERMANENT/TEMPORARY	/	/	/	/	/	/
MAN MONTHS (P./T.)	/	/	/	/	/	/

III. ANALYSIS (See Fiscal Note Preparation Instructions, Section III)

The removal or avoidance of architectural barriers in public places and facilities is to be accomplished within project contingency funds and, in the case of the major renovation or purchase of a ferry, is to be accomplished within the funds available.

IV. ATTACHMENTS

On Committee Instructions

V. DATE: 28 May 1976 PREPARED BY: James B. Rhode

James B. Rhode
 AA to the Chairman
 House Finance Committee

Original: Legislative Finance
 cc: Budget and Management
 Prime Sponsor (First Legislator Named)

Person this

Introduced: 4/11/75
Referred: Health, Education &
Social Services and Finance

1 IN THE HOUSE

BY HBEIRNE AND OSTROSKY

2 SPONSOR SUBSTITUTE FOR HOUSE BILL NO. 225

3 IN THE LEGISLATURE OF THE STATE OF ALASKA

4 NINTH LEGISLATURE - FIRST SESSION

5 A BILL

6 For an Act entitled: "An Act relating to the elimination of architectural
7 barriers in public buildings and facilities for physi-
8 cally handicapped, aged or infirm persons; and provi-
9 ding for an effective date."

10 BE IT ENACTED BY THE LEGISLATURE OF THE STATE OF ALASKA:

11 * Section 1. AS 35.10.015 is amended to read:

12 Sec. 35.10.015. ARCHITECTURAL BARRIER REGULATIONS; ENFORCEMENT.

13 The Department of Public Works shall prepare, promulgate and enforce
14 [IS RESPONSIBLE FOR PREPARING AND PROMULGATING] regulations governing
15 the construction of public buildings and facilities by or for the state,
16 including the University of Alaska, and its political subdivisions,
17 whether financed in whole or in part by federal ^{state or other public funds} funds, to insure that
18 the public buildings and facilities are accessible to, and usable by,
19 the physically handicapped, aged or infirm. The regulations of the
20 department shall conform to applicable provisions of federal law or
21 regulation and [AS FAR AS IT IS FEASIBLE] to the publication entitled
22 "American Standard Specifications for Making Buildings and Facilities
23 Accessible to and Usable by the Physically Handicapped" or any amend-
24 ments to this publication as approved by the American Standards Associa-
25 tion, Incorporated, under the sponsorship of the National Society for
26 Crippled Children and Adults and the President's Committee on Employment
27 of the Physically Handicapped.

28 * Sec. 2. AS 35.10.015 is amended by adding a new subsection to read:

29 (b) In (a) of this section, "public facilities" includes vessels

1 owned by the state and operated by the division of marine transportation
2 of the Department of Public Works as a part of the Alaska marine highway
3 system. All ferries owned or operated by the state shall be equipped
4 with elevators or other passenger lifting equipment ramps, or other
5 facilities and devices to ensure that these vessels are accessible to
6 and usable by physically handicapped, aged or infirm passengers. In
7 this subsection, "accessible to and usable by" means that a physically
8 handicapped, aged or infirm passenger can board, disembark and move
9 between decks and about the public areas aboard a state ferry with
10 personal comfort and with safety to himself, other passengers and members
11 of the crew.

12 * Sec. 3. After the effective date of this Act, no ferry may be con-
13 structed, lengthened, completely renovated, or purchased, ~~leased or otherwise~~
14 ~~acquired~~ for use or entered into service by the division of marine transporta-
15 tion of the Department of Public Works as a part of the Alaska marine highway
16 system that does not include ~~elevators or other passenger lifting equipment,~~ ^{adequate}
17 ~~ramps, or other~~ facilities and devices to ensure that the vessel is acces-
18 sible to and usable by physically handicapped, aged or infirm passengers.
19 Some staterooms, ~~all public~~ restrooms, indoor passageways and outdoor weather
20 decks, and other public areas aboard the vessel shall be so designed and
21 constructed as to permit access and use by physically handicapped, aged or
22 infirm passengers, including but not limited to those persons occupying a
23 wheelchair.

24 * Sec. 4. After the effective date of this Act, no public building or
25 ~~facility~~ ^{public} in the state may be ~~planned,~~ ^{initiated} designed, financed, ^{or} constructed, ^{or} ~~opened~~
26 ~~to public use, or otherwise placed in operation~~ unless it meets the standards
27 established under AS 35.10.015, as amended by this Act. A public building or
28 facility in existence on the effective date of this Act that does not conform
29 to the standards prescribed in AS 35.10.015, as amended by this Act, shall be

1 brought into conformity with those standards not later than 10 years after
2 the effective date of this Act.

3 * Sec. 5. This Act takes effect immediately in accordance with AS 01.10.-
4 070(c).

5 *g r r y p d i o e y p*
6 *clause of y s p s c wain*
7 *g r r c . a l a g a p o n e s*
8 *o b d v M o g o c v m e*
9 *r r b r a) (. g r v r v*
10 *f = 3 p g s h c wain i n e*
11 *g r*
12
13
14
15
16
17
18
19
20
21
22
23
24
25
26
27
28
29

AMENDMENT #1

OFFERED IN THE HOUSE:

BY: HESS COMMITTEE

To: _____ HOUSE BILL No. SSHB 225am

SENATE BILL No. _____

(1)	PAGE: <u>1</u>	LINE: <u>8</u>
(2)	PAGE: <u>1</u>	LINE: <u>19</u>
(3)	PAGE: <u>1</u>	LINE: <u>17</u>
(4)	PAGE: <u>2</u>	LINE: <u>25 & 26</u>

P. 1, line 8 (1) Delete "infirm" and add "infirm"

P. 1 line 19 (2) Delete "infirm" and add "infirm"

P. 1 line 17 (3) After the word "federal," add "state or other public funds,"

P. 2 lines 25-26 (4) Delete sentence after "be" through "operation" on Line 26 and insert "initiated for planning, design, finance, and construction,"

An Act relating to the elimination of architectural barriers in public buildings and facilities for physically handicapped, aged or infirm persons; e.d."

REVISED

COMMITTEE REPORT

SSHB 225 in finance

4/17/75

HOUSE

Mr. Speaker:

Date 4-18-75

The Committee on HESS
FINANCE has had SSHB 225

under consideration. A Majority of the members of the Committee

() recommends it DO PASS

() recommends it DO NOT PASS

() recommends it DO PASS WITH ATTACHED AMENDMENT(S)

() recommends it BE REPLACED WITH CS FOR _____ AND THAT
CS FOR _____ DO PASS

() "and" recommends it BE REFERRED TO THE _____
COMMITTEE

() reports it back ^{ind.} WITHOUT RECOMMENDATION *& w/out any.*

() "other"

Members signing the Majority report:

- ① Susan Sullivan Do Pass
- ① Kathryn Ostradky " "
- ① Helen Baines " "

Members NOT concurring in the Majority report:

- ① Steve Hackney recommends: NO REC
- ① Alvin Ostradky recommends: NO REC
- ① _____ recommends: no recommendation
- ① John E. Sullivan recommends: do not pass
- ① _____ recommends: & w/out any

Susan Sullivan Chairman

of planning, land acquisition, construction and maintenance of flood control projects authorized within the state by the United States before or after June 6, 1971, except that the state shall assume the full share of nonfederally funded costs with respect to those facilities which are primarily state responsibilities, including but not limited to highways and roads, parks and recreation, and fish and game facilities. The state shall participate in federal flood control projects under this section only as to those projects authorized and approved by the Department of Public Works. (§ 1 ch 129 SLA 1971)

Chapter 10. Public Works.

Article

3. Financial Provisions (§§ 35.10.130—35.10.135)

Article 1. Public Works Planning and Construction.

Section

15 Architectural barrier regulations
20. Consultation with municipal planning commissions

Section

25. Compliance with local building codes

Sec. 35.10.015. Architectural barrier regulations. The Department of Public Works is responsible for preparing and promulgating regulations governing the construction of public buildings and facilities by or for the state, including the University of Alaska, and its political subdivisions to insure that the public buildings and facilities are accessible to, and usable by, the physically handicapped. The regulations of the department shall conform as far as it is feasible to the publication entitled "American Standard Specifications for Making Buildings and Facilities Accessible to and Usable by the Physically Handicapped" or any amendments to this publication as approved by the American Standards Association, Incorporated, under the sponsorship of the National Society for Crippled Children and Adults and the President's Committee on Employment of the Physically Handicapped. (§ 1 ch 119 SLA 1966; am § 1 ch 48 SLA 1972)

Effect of amendment. — The 1972 amendment inserted "including the University of Alaska" in the first sentence. **Legislative committee report.** — For legislative committee report on ch. 119 SLA 1966. see House Journal (1966), p. 889.

Sec. 35.10.020. Consultation with municipal planning commissions. Before the construction of a public works in a municipality, the department shall confer with the planning commission of the municipality to determine that the welfare of the public is properly protected. Real property of the state which is leased, sold, exchanged or otherwise transferred for value to other than a public



Public Law 90-480
90th Congress, S. 222
August 12, 1968

An Act

To insure that certain buildings financed with Federal funds are so designed and constructed as to be accessible to the physically handicapped.

Be it enacted by the Senate and House of Representatives of the United States of America in Congress assembled, That, as used in this Act, the term "building" means any building or facility (other than (A) a privately owned residential structure and (B) any building or facility on a military installation designed and constructed primarily for use by able bodied military personnel) the intended use for which either will require that such building or facility be accessible to the public, or may result in the employment or residence therein of physically handicapped persons, which building or facility is—

Public build-
ings.
Accessibility
to physically
handicapped.

82 STAT. 718

82 STAT. 719

(1) to be constructed or altered by or on behalf of the United States;

(2) to be leased in whole or in part by the United States after the date of enactment of this Act after construction or alteration in accordance with plans and specifications of the United States; or

(3) to be financed in whole or in part by a grant or a loan made by the United States after the date of enactment of this Act if such building or facility is subject to standards for design, construction, or alteration issued under the authority of the law authorizing such grant or loan.

Sec. 2. The Administrator of General Services, in consultation with the Secretary of Health, Education, and Welfare, is authorized to prescribe such standards for the design, construction, and alteration of buildings (other than residential structures subject to this Act and buildings, structures, and facilities of the Department of Defense subject to this Act) as may be necessary to insure that physically handicapped persons will have ready access to, and use of, such buildings.

Standards.

Sec. 3. The Secretary of Housing and Urban Development, in consultation with the Secretary of Health, Education, and Welfare, is authorized to prescribe such standards for the design, construction, and alteration of buildings which are residential structures subject to this Act as may be necessary to insure that physically handicapped persons will have ready access to, and use of, such buildings.

Sec. 4. The Secretary of Defense, in consultation with the Secretary of Health, Education, and Welfare, is authorized to prescribe such standards for the design, construction, and alteration of buildings, structures, and facilities of the Department of Defense subject to this Act as may be necessary to insure that physically handicapped persons will have ready access to, and use of, such buildings.

Sec. 5. Every building designed, constructed, or altered after the effective date of a standard issued under this Act which is applicable to such building, shall be designed, constructed, or altered in accordance with such standard.

Applicability.

Sec. 6. The Administrator of General Services, with respect to standards issued under section 2 of this Act, and the Secretary of Housing and Urban Development, with respect to standards issued under section 3 of this Act, and the Secretary of Defense with respect to standards issued under section 4 of this Act, is authorized—

(1) to modify or waive any such standard, on a case-by-case basis, upon application made by the head of the department, agency, or instrumentality of the United States concerned, and

Waiver.

99-081 O

Pub. Law 90-480
82 STAT. 717

- 2 -

August 12, 1968

upon a determination by the Administrator or Secretary, as the case may be, that such modification or waiver is clearly necessary, and

Surveys and
Investigations.

(2) to conduct such surveys and investigations as he deems necessary to insure compliance with such standards.

Approved August 12, 1968.

Mr. Fred Chiei, Jr.
P. O. Box 148
Anchorage, Alaska 99501
March 25, 1975

Representative Helen D. Beirne
Pouch V
Juneau, Alaska 99801

Dear Helen:

Many thanks for sending copies of House Bills 12, 13, and 225. The Borough Mayor's Committee of Employment of the Handicapped has reviewed the Bills and endorses and supports same with the addition of, or consideration of the following:

GOVERNOR'S PUBLIC SAFETY LEGISLATION

1. Is the \$30 fee in addition to the regular fee?
2. What will this special plate entitle one to?
3. Will disabled vets have to pay the fee? They now get free plates if 70% disabled.
4. Do they not mean physically rather than medically disabled?
5. Would not a VA certification suffice for disabled veterans? See line 19, page 2, HR 1051, copy attached.

HB 225

Page 1, Lines 8 and 19 -- should read infirmed

Line 15 -- suggest the following wording....for the state, political subdivisions of the state and the University of Alaska

Line 15 -- suggest types of public buildings that this law is to cover be spelled out as in Section 6-19 of South Bend Ordinance 5475-73, copy attached.

Line 17 -- suggest the following wording, "whether financed in whole or in part by federal state or other public funds",...

Line 27 -- suggest more specific statement of standards

International Brotherhood of
PAINTERS and ALLIED TRADES
A.F.L. - C.I.O.
LOCAL UNION 1140

1818 WEST NORTHERN LIGHTS • ANCHORAGE, ALASKA 99503 • 277-0832



April 11, 1975

Representative Helen Beirne
Alaska State House of Representatives
Pouch "Y", State Capitol Building
Juneau, Alaska 99811

Dear Representative Beirne:

Hopefully, the enclosed booklets will be of some help in preparing legislation affecting the needs of Alaska handicapped citizens.

In regard to the handicapped program, we certainly hope you are effective in getting the State to become more involved in its commitment to the affirmative action program for handicapped workers in Alaska.

We were proud of your participation in our May 31, 1974 program. However, the costs of these kinds of programs should be paid entirely by the state — not private entities as is presently done.

Trusting that we have an opportunity to meet and discuss the matter, I remain

Sincerely,

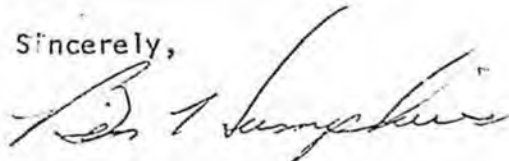

Ben Humphries,
Chairman/G.C.E.H.

BH/mn

Enclosures

STATE OF ALASKA

DEPARTMENT OF EDUCATION

OFFICE OF VOCATIONAL REHABILITATION

JAY S. HAMMOND, Governor

April 11, 1975

The Honorable Susan Sullivan, Chairman
HESS Committee
The House of Representatives
Alaska State Legislature

Dear Susan;

In discussions with some legislative staff members and Helen Beirne, it would seem that the House HESS Committee is experiencing some problems with House Bill 225 on Architectural Barriers. Apparently there are some members of the Committee that feel that because this bill addresses itself to only a small number of people, the necessary expenditures and state guidelines cannot be justified.

I would certainly agree that it is a more expensive proposition to construct a building having free access for handicapped individuals than one without such considerations. However, we have made a long standing commitment over the last 55 years towards the less fortunate, disabled citizens in our country. I sincerely feel that we must be concerned about the total individual rather than just a part, and that the needs of the handicapped include any easement of mobility and access problems that are within our grasp to provide.

As an agency working in the field of rehabilitation, we would certainly support this bill and its concept. Since I was out of town at the time of your initial hearings on this bill, I am uncertain as to whether you received a copy of my prepared testimony. I am therefore enclosing a copy for your use. I have also attached a copy of the standards from the state of Washington, which have been promulgated as a result of their state statutes.

If I can be of any further assistance in this matter, please do not hesitate to call me at 465-2897.

Sincerely yours,



Michael C. Morgan
Director

MCM:sw

Enclosures: As stated

CORRECTION

THIS DOCUMENT
HAS BEEN REPHOTOGRAPHED
TO ASSURE LEGIBILITY

Mr. Fred Chiei, Jr.
P. O. Box 148
Anchorage, Alaska 99501
March 25, 1975

Representative Helen D. Beirne
Pouch V
Juneau, Alaska 99801

Dear Helen:

Many thanks for sending copies of House Bills 12, 13, and 225. The Borough Mayor's Committee of Employment of the Handicapped has reviewed the Bills and endorses and supports same with the addition of, or consideration of the following:

GOVERNOR'S PUBLIC SAFETY LEGISLATION

1. Is the \$30 fee in addition to the regular fee?
2. What will this special plate entitle one to?
3. Will disabled vets have to pay the fee? They now get free plates if 70% disabled.
4. Do they not mean physically rather than medically disabled?
5. Would not a VA certification suffice for disabled veterans? See line 19, page 2, HR 1051, copy attached.

HB 225

Page 1, Lines 8 and 19 -- should read infirmed

Line 15 -- suggest the following wording....for the state, political subdivisions of the state and the University of Alaska

Line 15 -- suggest types of public buildings that this law is to cover be spelled out as in Section 6-19 of South Bend Ordinance 5475-73, copy attached.

Line 17 -- suggest the following wording, "whether financed in whole or in part by federal state or other public funds",...

Line 27 -- suggest more specific statement of standards

Representative Helen D. Beirne
March 25, 1975
Page two

Line 27 -- similar to that in Section 6 thru 6-33
(cont.) of South Bend, Ind Ordinance

HB 13

Page 1, Line 16 -- suggest a requirement for adequate state-
rooms, stairways, ramps, toilets, drinking
fountains and other convenience facilities
be included.

Additionally, I am enclosing other similar bills which have been in
the Congress for informational use. Also a model ordinance from the
City of South Bend.

If we can be of additional help please don't hesitate to contact me.

Sincerely,



FRED CHIEI, JR.
Chairman, Borough Mayor's
Committee on Employment of
the Handicapped

FC/vk

Enclosure:

International Brotherhood of
PAINTERS and ALLIED TRADES
A.F.L. - C.I.O.
LOCAL UNION 1140

1818 WEST NORTHERN LIGHTS • ANCHORAGE, ALASKA 99503 • 277-0832



April 11, 1975

Representative Helen Beirne
Alaska State House of Representatives
Pouch "Y", State Capitol Building
Juneau, Alaska 99811

Dear Representative Beirne:

Hopefully, the enclosed booklets will be of some help in preparing legislation affecting the needs of Alaska handicapped citizens.

In regard to the handicapped program, we certainly hope you are effective in getting the State to become more involved in its commitment to the affirmative action program for handicapped workers in Alaska.

We were proud of your participation in our May 31, 1974 program. However, the costs of these kinds of programs should be paid entirely by the state — not private entities as is presently done.

Trusting that we have an opportunity to meet and discuss the matter, I remain

Sincerely,

Ben Humphries,
Chairman/G.C.E.H.

BH/mn

Enclosures

STATE OF ALASKA

JAY S. HAMMOND, Governor

DEPARTMENT OF EDUCATION

OFFICE OF VOCATIONAL REHABILITATION

April 11, 1975

The Honorable Susan Sullivan, Chairman
HESS Committee
The House of Representatives
Alaska State Legislature

Dear Susan;

In discussions with some legislative staff members and Helen Beirne, it would seem that the House HESS Committee is experiencing some problems with House Bill 225 on Architectural Barriers. Apparently there are some members of the Committee that feel that because this bill addresses itself to only a small number of people, the necessary expenditures and state guidelines cannot be justified.

I would certainly agree that it is a more expensive proposition to construct a building having free access for handicapped individuals than one without such considerations. However, we have made a long standing commitment over the last 55 years towards the less fortunate, disabled citizens in our country. I sincerely feel that we must be concerned about the total individual rather than just a part, and that the needs of the handicapped include any easement of mobility and access problems that are within our grasp to provide.

As an agency working in the field of rehabilitation, we would certainly support this bill and its concept. Since I was out of town at the time of your initial hearings on this bill, I am uncertain as to whether you received a copy of my prepared testimony. I am therefore enclosing a copy for your use. I have also attached a copy of the standards from the state of Washington, which have been promulgated as a result of their state statutes.

If I can be of any further assistance in this matter, please do not hesitate to call me at 465-2897.

Sincerely yours,



Michael C. Morgan
Director

MCM:sw

Enclosures: As stated

Mobility Barriers

FEB 18 1975

The following standards, in bold capital letters, are from A.N.S.I. standard A117.1-1961 (Reaffirmed 1971), and are required under State of Washington law in covered situations. The numbers in parentheses refer to paragraph numbers in the standards. Those items which are in lower case type are not required by the standards, but would be desirable to include in barriers-removal work.

Grades

GRADE AGAINST EXISTING TOPOGRAPHY IF NECESSARY SO AS TO ATTAIN LEVEL GRADES AT ENTRANCES. (4.1)

PUBLIC WALKS SHOULD BE NOT LESS THAN 48 INCHES WIDE AND SHOULD HAVE A SLOPE OF NOT MORE THAN 5 PERCENT. (4.2)

PARKING SPACES RESERVED FOR DISABLED PERSONS SHOULD BE 12 FEET WIDE. (4.3.3)

RAMPS, WITH A SLOPE NOT GREATER THAN A 1 FOOT RISE FOR EVERY 12 FEET OF HORIZONTAL DISTANCE SHOULD AUGMENT STEPS OR STAIRS. RAMPS SHOULD HAVE A HANDRAIL 32 INCHES HIGH ON ONE OR BOTH SIDES. (5.1)

Outdoor ramps should have automatic snow-melting capability or should be protected by walls and roof, preferably by clear plastic or translucent walls.

Doors

AT LEAST ONE PRIMARY ENTRANCE (EXIT) TO EACH BUILDING SHOULD BE USABLE BY PERSONS IN A WHEELCHAIR. THE ENTRANCE (EXIT) SHOULD BE AT A LEVEL ACCESSIBLE TO ELEVATORS. (5.2)

DOORS SHOULD HAVE A CLEAR OPENING, WHEN OPEN, OF AT LEAST 32 INCHES, AND THE FLOOR ON EACH SIDE OF THE DOOR SHOULD BE LEVEL FOR 5 FEET. (5.3)

RAISED OR RECESSED ROOM NUMBERS OR ROOM NAMES, CAPABLE OF BEING FELT BY A BLIND PERSON, SHOULD BE INSTALLED. (5.11)

The force required to open a door should not be more than 8 pounds. This can be measured with a fish scale.

If accessibility by quadraplegics is required, there should be automatic electric eye door openers installed.

If there is an inner door and an outer door, there should be at least 6 1/2 feet between the two doors.

Stairways

THE NOSING ON STEPS SHOULD NOT PROJECT. (THE TREAD SHOULD NOT EXTEND BEYOND THE RISER.) (5.4)

STAIRS SHOULD HAVE HANDRAILS 32 INCHES HIGH. WHERE BUILDING CODES PRESCRIBE OTHER HEIGHTS, THERE SHOULD BE TWO SETS OF HANDRAILS, ONE AT EACH HEIGHT. (5.4)

RISERS ON STAIRS SHOULD NOT EXCEED 7 INCHES. (5.4)

Toilets

TOILET STALLS (AT LEAST ONE STALL PER TOILET ROOM) SHOULD HAVE AN OUTWARD SWINGING DOOR (WHEN DOORS ARE USED) WHICH IS 32 INCHES WIDE. THE STALL ITSELF SHOULD BE AT LEAST 3 FEET WIDE AND 5 FEET DEEP. THE STALL SHOULD HAVE HANDRAILS ON EACH SIDE WHICH ARE 33 INCHES HIGH, 1 1/2 INCHES O.D., AND WITH 1 1/2 INCHES OF CLEARANCE BETWEEN HANDRAIL AND WALL, AND FASTENED SECURELY AT ENDS AND CENTER. (5.6)

The fastenings for the handrails in the toilet stall should withstand a force of at least 400 pounds.

Washrooms

SINKS SHOULD HAVE A CLEAR SPACE BENEATH THEM OF AT LEAST 30 INCHES FROM THE FLOOR (5.6.3 AND 3.1)

HOT WATER PIPES AND DRAIN PIPES UNDER A SINK SHOULD BE INSULATED. (5.6.3)

Faucet handles should be levers rather than knobs.

TOWEL RACKS, TOWELS, OTHER DISPENSERS, AND DISPOSAL UNITS SHOULD BE MOUNTED NO HIGHER THAN 40 INCHES FROM THE FLOOR.

The "H" and "C" designations on hot and cold water faucet handles should be raised or recessed so that they can be felt by a blind person.

ACCESSIBLE MIRRORS SHOULD BE MOUNTED WITH THE LOWER EDGE NOT MORE THAN 40 INCHES FROM THE FLOOR (5.6.4)

ACCESSIBLE SHELVES SHOULD BE PROVIDED WITH THE UPPER SURFACE OF THE SHELF NOT MORE THAN 40 INCHES FROM THE FLOOR. (5.6.4)

Drinking Fountains

WATER FOUNTAINS SHOULD NOT BE RECESSED INTO THE WALL. (5.7.2)

WATER COOLERS SHOULD HAVE A SMALL FOUNTAIN MOUNTED TO THE SIDE OF THE COOLER (A "LOW BOY") AT 30 INCHES ABOVE THE FLOOR. (5.7.2)

A higher drinking fountain may be made accessible by mounting a paper cup dispenser on the wall near the fountain, with the bottom of the dispenser 36 inches above the floor. A sign on the dispenser should indicate "For handicapped persons."

Telephones

AN ACCESSIBLE PHONE SHOULD BE PROVIDED WHICH IS EQUIPPED FOR PARTIALLY DEAF PERSONS AND SO IDENTIFIED WITH INSTRUCTIONS FOR USE. (5.8.2)

AN ACCESSIBLE PHONE, NOT IN A BOOTH, SHOULD BE MOUNTED LOW ENOUGH SO THAT THE INSTRUMENT, THE DIAL, AND THE COIN SLOTS MAY BE REACHED AND OPERATED BY A PERSON IN A WHEELCHAIR. (5.8.1)

Elevators

ELEVATOR(S) SHOULD BE AVAILABLE ON THE FLOOR WHICH PROVIDES ACCESS AND EXIT TO THE BUILDING, AND AT ALL LEVELS NORMALLY USED BY THE PUBLIC. (5.9.1)

ELEVATORS SHOULD BE LARGE ENOUGH TO ACCOMMODATE WHEELCHAIRS. (5.9.2)

Control buttons in elevators should be mounted low enough to be accessible to persons in a wheelchair, and should have floor numbers embossed or recessed on the buttons so that they can be felt by a blind person. The "up" and "down" buttons outside the elevator, and used to call the elevator, should be positioned one above the other and be similarly embossed or recessed with a "U" and a "D", or with arrows pointing up and down.

Hazards

OBVIOUS HAZARDS TO DISABLED PEOPLE, AS WELL AS TO PEOPLE WITHOUT DISABILITIES, SUCH AS MANHOLES, LOW-HANGING SIGNS, LOW CEILING LIGHTS OR FIXTURES, ETC., SHOULD BE AVOIDED. (5.12)

The material shown on these pages merely summarizes the standards.

To know the exact standards, the standards themselves should be obtained and read. The state law refers to the full ASA 117.1-1951 standards, and not to any summary thereof.

Copies of ASA 117.1-1961 may be obtained from:

American National Standards Institute
1430 Broadway
New York, N. Y. 10018

Public Law 93-112 (93rd Congress), passed on September 26, 1973 has a Section 503 which obligates any contractor with the Federal Government, in any amount in excess of \$2500, to take affirmative action to employ qualified handicapped people.

The Federal Register, Volume 39, Number 113, dated June 11, 1974 contains regulations pertaining to affirmative action, which will be enforced by the Department of Labor. Par. 741.4(c) (page 20568) refers to "accommodation." As used by the Department of Labor, "accommodation" will mean, among other things, the elimination of architectural barriers to disabled people.

If you are a contractor or subcontractor with the Federal Government, the Department of Labor will take a direct interest in the removal of mobility barriers at your place of business as evidence of your "accommodation" of handicapped people.

ALASKA TREATMENT CENTER

for

Crippled Children & Adults, Inc.

3710 E. 20th Ave.,

Anchorage, Alaska 99504

Phone (907) 272-0586



April 7, 1975

Representative Helen D. Beirne
Box 4-BB
Anchorage, Alaska

Dear Helen:

Regarding House Bill #225 which has to do with architectural barriers, I urge that you support this bill and recommend its passage from committee. I also strongly recommend that a fiscal note be attached to the bill to begin the work of providing access to public buildings and on vessels of the Marine Highway.

As a person involved with people who experience difficulty with access to public facilities, I feel that this bill is of top priority.

Thank you for your assistance.

Sincerely yours,

KEITH W. TOLZIN
Executive Director

jck

THE EASTER SEAL SOCIETY FOR ALASKA CRIPPLED CHILDREN AND ADULTS

EASTER SEAL INFORMATION AND
REFERRAL SERVICE
P. O. BOX 2432
ANCHORAGE, ALASKA 99510
274-1641



STATE SOCIETY OFFICE
P. O. BOX 2432 99510
726 E STREET 99501
ANCHORAGE ALASKA
277-1323

16 April 1975

Donald Harris, Commissioner
Alaska State Department of Public Works
Pouch 7
Juneau, Alaska 99811

Dear Mr. Harris:

The Easter Seal Society for Alaska Crippled Children and Adults, Inc. continues to be concerned with the elimination of architectural barriers in public buildings and facilities for use by all people, including the handicapped.

The present law is weak because of the Waiver clause - "the regulations of the department shall conform as far as feasible" to the standards. If this clause isn't deleted from the present law it will continue to prove more costly to the state as the state is made to comply with the regulation at a later date.

The present law is also weak in that it fails to provide for enforcement of the regulations. Since the Department of Public Works is responsible for carrying out these regulations, enforcement should also be included.

We are enclosing some materials on the elimination of architectural barriers in public buildings and facilities and hope that you will support House Bill #225.

Sincerely yours,

Mary Tomaszewicz, Coordinator
Information and Referral Service

cc: Rep. Helen Beirne ✓
Mrs. E. Mackin, President ACCA

THE EASTER SEAL SOCIETY FOR ALASKA CRIPPLED CHILDREN AND ADULTS

EASTER SEAL INFORMATION AND
REFERRAL SERVICE
P. O. BOX 2112
ANCHORAGE, ALASKA 99510
274-1641



STATE SOCIETY OFFICE
P. O. BOX 2432 99510
726 E STREET 99501
ANCHORAGE, ALASKA
277-1324

16 April 1975

Susan Sullivan, Chairman
House Health, Education and Social Services Committee,
Pouch V
Juneau, Alaska 99801

Dear Mrs. Sullivan:

The Easter Seal Society for Alaska Crippled Children and Adults, Inc. continues to be concerned with the elimination of architectural barriers in public buildings and facilities for use by all people, including the handicapped. We recognize the inherent right of all citizens to the full development of their potential, regardless of their physical disability through the free use of the man-made environment.

Enclosed are some materials on architectural barriers which we hope you will share with your committee members.

Hopefully, the committee will realize the importance of having a law which will eliminate the loopholes of non enforcement and the waiver clause of conforming "as far as feasible". In the long run House Bill #225 will save the state money as existing construction wouldn't have to be changed to comply at a later date.

Please support House Bill #225.

Yours very truly,

Mary Tomaszewicz, Coordinator
Information and Referral Service

cc: Rep. Helen Beirne ✓
Mrs. E. Mackin, President ACCA

**Tourism
is everybody's
business.**



Alaska Visitors Association

P. O. Box 2208, Anchorage, Alaska 99510

(907) 279-4116

April 16, 1975

The Honorable Helen D. Beirne
Alaska State House of Representatives
Pouch V, State Capitol Building
Juneau, AK 99801

Dear Representative Beirne:

Attached is a copy of the testimony recently presented to the House and Senate Finance Committees by AVA Legislative Chairman, John G. Stevens.

I know that you, along with most of our State legislators, look upon the Alaska Visitor Industry as a vital part of our economy with a bright future. Many legislators have asked me "What can I do to help Alaska's tourism prosper?" My response is the recommendations included in this position paper, and your support of C.S. for S.B. 225 as it applies to the Alaska State Division of Tourism.

May I respectfully suggest you consider this material and take appropriate steps to help implement this funding and legislative request.

Sincerely,

Bud Hagberg
A. E. "Bud" Hagberg
President

RECOMMENDATIONS FOR AFFIRMATIVE ACTION
TOWARD EQUAL EMPLOYMENT OPPORTUNITY
FOR ALASKA'S HANDICAPPED WORKERS

Prepared by

The Action Plan Task Force,
Governor's Advisory Committee
on the Employment of the
Handicapped

Submitted to

Mr. Ben Humphries, Chairman
Governor's Advisory Committee
on the Employment of the
Handicapped

January 31, 1974

R E C O M M E N D A T I O N S

RECOMMENDATION NO. 1

Elimination of Architectural Barriers.

Architectural barriers are often the most difficult problems faced by the handicapped worker. The elimination of these barriers is often the most expensive affirmative action necessary to employ handicapped workers. Toward this end, the State should adopt the American Standard specifications for making buildings and facilities accessible to, and usable by, the physically handicapped worker. These standards, developed by the American Standards Association, Inc. under the sponsorship of the National Society for Crippled Children and Adults, and the President's Committee on the Employment of the Physically Handicapped, are included in this report as Appendix A.

While the State should do everything it can to render its own buildings and facilities barrier-free for handicapped workers, it should also assist private employers and local

government to modify their buildings to eliminate barriers to employment. The legislature should be asked to appropriate funds to:

- (1) Finance barrier removal in State-owned or leased facilities.
- (2) Subsidize part of the cost of modifying privately-owned buildings and facilities.

In addition, the Legislature should pass legislation to create special tax incentives for investment in building modification by private employers necessary to overcome employment barriers.

RECOMMENDATION NO. 2

Survey of Handicapping Conditions.

Several years have elapsed since a comprehensive survey was made of handicapping conditions in the State. New survey work should be undertaken with both short and long-range goals:

Short-range.

Survey work should be undertaken to determine exactly who are Alaska's handicapped job ready workers, and to inventory their problems. This survey should determine general characteristics of the entire population of handicapped workers in the State, as well as perform in-depth research into the problems, attitudes and perceptions of a statistical sample of this population.

Long-range.

As has been done in the past, a complete census should be taken of handicapping conditions. This door-to-door survey would be aimed at updating data available about the true incidence and distribution of handicapping conditions throughout the State, and provide information necessary to the prevention of unemployment of handicapped workers.

Remodeling To Aid Disabled

Elevators and automatic doors will be installed this fall to make several buildings at the University of Alaska, Anchorage campus more accessible to handicapped students.

The project is being funded through a \$52,000 grant from the Office of Vocational Rehabilitation of the State Department of Education.

Les James, director of the state office, and Dale Reeves, Chief of Rehabilitation Services, presented a check for \$39,000 to Dr. Lewis E. Haines, provost of the university's Southcentral region, to pay 75 per cent of the installation costs. The remainder of the \$52,000 grant will be paid upon completion of the work.

Under terms of the

agreement, elevators will be installed in the two-story Short and McDonald buildings, and automatic doors will be installed at the Cuddy Campus

James said that 126 students who are clients of the rehabilitation office are enrolled at the Anchorage campus and many more persons who suffer some type of disability would also benefit



TOPIC IS REHABILITATION

Les James, director of the state office of Vocational Rehabilitation, right, discusses some of the problems of handicapped students at the University of Alaska, Anchorage with Dr. Lewis E. Haines, provost for the university's Southcentral region. With them is Rick Jarvis, left, former student government leader at the Anchorage campus and now a rehabilitation assistant. The group visited the campus to present a check to Haines to finance installation of elevators and automatic doors in several buildings on campus.

THE NEWS

working together...

THE KEY TO JOBS FOR THE HANDICAPPED

AN AFL-CIO GUIDE

They are always more difficult to absorb into the work force than any other type of handicapped person because misunderstanding is truly formidable.

Good advice is contained in pamphlets obtainable from the governor's committee in state capitals. For information about disabled veterans contact the Veterans Administration or the President's Committee on Employment of the Handicapped, Washington, D.C. 20210.

Placing the handicapped

Selective placement means matching the physical abilities of the disabled with the physical demands of the job. It is the simple application of common sense.

Proper placement of a handicapped worker, as with any worker, is insured when (1) the full job requirements of skill, experience, aptitude, training, and education have been met; (2) the physical ability of the disabled worker is equal to the physical demands of the job; (3) the physical condition of the worker will not be aggravated by the physical demands and working conditions; and (4) the job duties or working conditions of the handicapped worker will not result in undue hazards to himself or others.

A job can be made more suitable and safe by a slight change in on-the-job duties or machine controls—such as shifting a lever from right to left hand operation or from hand to foot control or vice versa. Telephones are available with simple dial controls for persons with a slight hearing aggravation. Transferring duties involving activities or conditions unsuitable or unsafe may permit these workers to perform with full satisfaction.

With very few exceptions, handicapped applicants present practically no problems different from any other applicants. Most handicapped persons

have lived with their impairment for a long period and relish an opportunity to show what they can do.

An effective program for employment of the handicapped requires all the resources of the community. This is an area in which no local group can go it alone. Where there is no mayor's or community committee, local union officials can spearhead a drive to arouse community interest in the problem and can try to get the mayor to organize such a committee. Often the best local person to help get a program started is the manager of the local public employment office.

Information on the organization and functions of a mayor's committee are spelled out in manuals and handbooks obtainable from the governor's committee.

Local union leadership needs a working knowledge of public and private agencies providing rehabilitation, employment and other services for the handicapped. All of these should be included on the membership of the local committee. Information on these groups is also spelled out in the materials obtainable from governors' committees.

The governor's committee can furnish printed materials, films and other public information tools, and can be particularly useful in forming a mayor's committee. The executive secretary of the governor's committee or the chairman will assist in organizing a local committee in towns and cities.

A related project is a nation-wide drive now under way to eliminate architectural barriers which prevent as many as 30 million fellow citizens who are limited by age or disability from entering and working in places of employment. These obstacles have been built into nearly all of the nation's factories, offices and other buildings.

After years spent on overcoming the reluctance of an employer to hire the

handicapped, it is ironic to have the paraplegic worker in a wheelchair arrive for work only to be locked out by an imposing flight of steps or other thoughtless building designs which separate his wheelchair from his work bench. Other barriers may be revolving doors, narrow doorways, narrow rest rooms, out-of-reach drinking fountains, inaccessible elevators, and many more.

The American Standards Association approved a set of specifications which would make all buildings and facilities fully accessible to the handicapped. To put these specifications into effect, architects can be involved to make sure that the specifications are incorporated into new buildings or modifications of existing buildings. Contractors should be urged to make certain the specifications become part of the buildings they are erecting. Building code authorities can be enlisted to take steps to incorporate these standards into building codes.

For information on architectural barriers write to the President's Committee on Employment of the Handicapped, Washington, D.C. 20210.

From time to time the President's Committee receives reports that in some plants all new employes may be required to start at the bottom as laborers and later be advanced to better jobs on the basis of seniority.

Because this kind of work may demand heavy, fast and continuous exertion, the employment of handicapped job applicants is almost completely blocked even though there are other jobs in the plant where the handicapped could be given a job opportunity. For that matter there are all kinds of handicaps. A deaf mute may have more strength than many already on the job.

Periodically the Governors' Committees on Employment of the Handicapped are asked to bring such conditions to the attention of the chairman of the President's Committee so that remedial steps can be taken by appropriate local labor officials.

openings and (2) give equal consideration in hiring to available handicapped workers who are to qualify for such openings.

Physical Examination: Pre-employment physical examinations shall not be made for any other purpose than to determine the physical abilities of the worker. The determination of the suitability of the job for the worker shall be made solely by the joint committee.

Seniority: If an employe because of physical disability is assigned to another department, he shall carry with him all seniority rights that he would have had in his former position.

The National Interest

Dr. Howard Rusk, one of the world's great authorities in physical medicine, says, "If we don't do more about using the disabled, the chronically ill, and the older worker, by 1980 for every able-bodied worker in America there will be one chronically ill, one physically handicapped, or one older worker over the age of 65 riding on every worker's back."

For every dollar that state and federal governments spend in handicapped rehabilitation, the restored worker will pay back many times as much in state and federal income taxes. But the dollar motive is not the important thing. Organized labor is dedicated to helping others help themselves. That's what solves the problem of the handicapped.

In America fundamental programs are based on recognition of the worth and dignity of each individual—in this instance the right of the handicapped as well as the able-bodied to be self-supporting, self-respecting, first class tax-paying citizens.



April 2, 1975

Mrs. H. Beirne
Alaska State House
Pouch V State Capitol Bldg.
Juneau, Alaska 99811

Dear Mrs. Beirne:

Thank you for your recent request for literature on the STAIR-GLIDE stairway lift.

STAIR-GLIDE is the largest selling stairway lift in the world. This success can be attributed to the unparalleled convenience of STAIR-GLIDE, our unique Rental-Purchase Program, the unit's low price, dependability, attractiveness, and ease of installation.

STAIR-GLIDE is the only company to offer a RENTAL-PURCHASE Program which enables you to rent a STAIR-GLIDE for seven months for a low monthly rental fee of \$55 per month. With this program, you have the option at the end of the rental period to apply all but the first month's rent toward the purchase price. If you elect not to purchase your STAIR-GLIDE at the end of the rental period, you may remove the unit and ship it back to our office in Grandview with no additional charge or obligation. This program is ideal for those individuals whose need for a STAIR-GLIDE may be temporary.

The price of a complete indoor STAIR-GLIDE is only \$1,295. This price includes track cut to fit your stairway; choice of color; standard, double arm or extra wide seat; seat belt; two year warranty; "call-send" controls at the top and bottom landings; and freight prepaid to your city.

The STAIR-GLIDE and track are made to fit your individual stairway specifications and are shipped ready for installation. The 12" wide aluminum track rests on the stairway and is attached at the top and bottom landings with a few small screws...there are no attachments to the wall or individual steps that will mar your stairway. Slide the unit into the track channels, insert the header assembly, attach the seat to the unit, plug in the electrical cord, and you are ready to enjoy the convenience of STAIR-GLIDE. No special wiring is required, and installation can be completed in a few hours by anyone handy with a few simple tools. We have a toll-free number to our service line that your installer can use to get questions answered regarding the installation.

Hundreds of STAIR-GLIDES have been installed in meeting halls and public buildings across the country for the benefit of the elderly and disabled who are unable to climb stairs. The convenience of STAIR-GLIDE has enabled these people to overcome the architectural barriers of the building and allows them to participate fully at meetings and functions they were once unable to attend.

Mrs. H. Beirne

-2-

April 2, 1975

When a STAIR-GLIDE is installed in a meeting hall or public building, we ask that the customer check with the local regulatory agency---usually the local building or elevator inspector or fire marshall--to insure that no local regulations will prohibit the installation.

Please find enclosed descriptive literature which will help acquaint you with STAIR-GLIDE. When you are ready to order your STAIR-GLIDE, please complete the information requested on the "Measurement Sheet and Order Form". Your check in the amount of \$1,295 should accompany the order for the purchase of a STAIR-GLIDE. If you elect to rent the STAIR-GLIDE, please submit the first and last months' rent (\$110) with the order. Normally, a unit can be shipped from our factory within four working days after we receive the order.

If after reading our material you have specific questions about STAIR-GLIDE, please jot them down and have them ready when I contact you later next week.

Sincerely yours,

AMERICAN STAIR-GLIDE CORPORATION

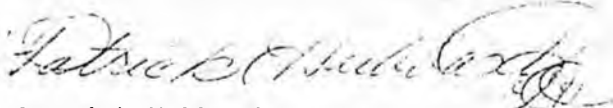

Patrick Hubbard
National Sales Representative

PH/jb

Enc.



THE CHENEY COMPANY

3015 SOUTH 163rd STREET
NEW BERLIN, WISCONSIN 53151

March 28, 1975



PHONE (414) 782-1100

Mrs. H. Beirne
Alaska State House
Pouch V, State Capitol Bld.
Juneau, AK 99811

Re: Your Inquiry: Your Church

Dear Mrs. Beirne:

Thank you for your recent letter. I am enclosing several copies each of our brochures on the products manufactured by our company; namely, the Wecolator Stairway Elevator, the Cheney Wheelchair Lift II and the Cheney Van Lift. We are the only company that manufactures a stairway elevator that can negotiate a curve or spiral turn! The Wecolator also was the first stairway elevator to be UL Listed.

We have installed both the Wecolator and the Wheelchair Lift II in churches and semi-public buildings throughout the United States. I am enclosing a copy of a recent Cheney News Letter depicting a Wheelchair Lift installation in a church in Wisconsin, as well as a copy showing an installation of a Wecolator Stairway Elevator in a church.

The Wecolator and the Wheelchair Lift both employ the use of a cog-drive mechanism. This feature insures the maximum in safety, as the machine stops immediately when the source of power is removed. The Wecolator can also be equipped with the following options:

1. Folding Swivel Seat - allowing easy exit by the passenger at the top.
2. Flip-up arm - especially helpful for a Wheelchair patient, allowing the passenger to get on the chair easier.
3. Horizontal Overrun - allow the passenger to get off the chair a safe distance from the top of the stairs on a flat surface.

Both the Wecolator and Wheelchair Lift must be keyed to prevent unauthorized use of the equipment and this option would be included. I hope the above answers many of your questions. Our representative, shown below, can help you decide on the best installation for your situation.

Sincerely,

Michael R. Bruno

MRB'jg

Our representative in your area:

Montgomery Elevator Company
P.O. Box 1405
Anchorage, AL 99501

Phone: 907-277-5224



WECOLATOR
STAIR CLIMBING ELEVATOR

“There’s a STAIR-GLIDE® to fit your stairway.”

Standard stairway

This is the standard stairway found in most homes. The versatility of STAIR-GLIDE® enables it to be mounted on either side of the stairs.

The track rests on the stairway and is attached by a few small screws to the top and bottom landings.

With the standard top extension, the track extends into the top landing approximately 14 inches, measured horizontally, which places the chair 17 inches above the landing. This allows the rider to rotate the seat a full 180 degrees so he can get off and on the unit in a normal sitting position facing away from the stairway.

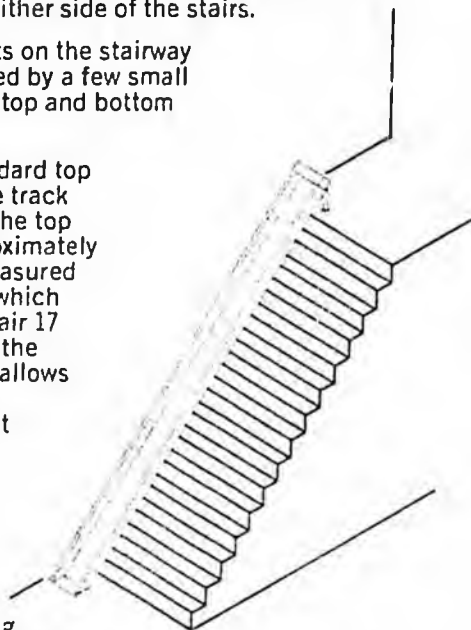

Pie-shaped landing (top)

When there are pie shaped steps near the top, the track should be extended all the way to the back wall. The special leg supports provided can both be mounted on Step 2, or one support can be mounted to Step 1 and the other to Step 2, depending upon the angle of the pie shaped step. The longer extension will enable the rider to get on and off the unit with his feet placed on Step 1 and 2.

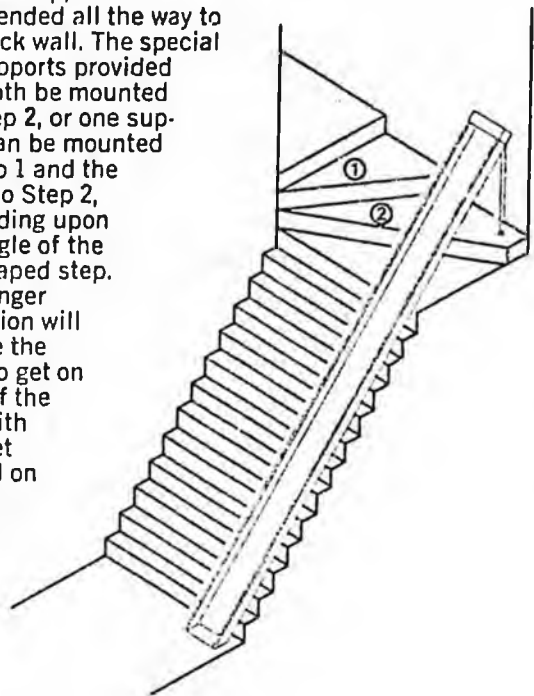

Pie-shaped landing (bottom)

When there are pie shaped steps near the the bottom, the track should rest on Step 1. Unless a STAIR-GLIDE[®] user is severely handicapped, the remaining few steps should not cause any inconvenience.

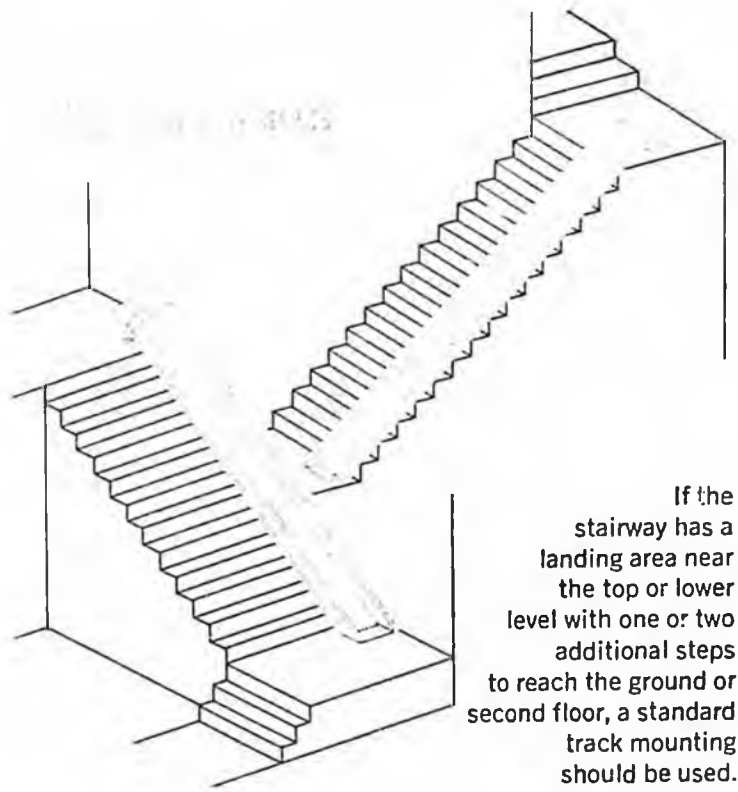
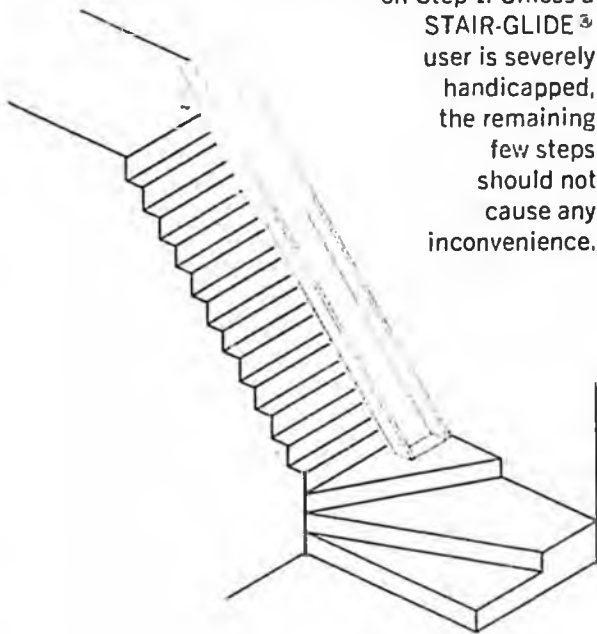

If the stairway has a landing area near the top or lower level with one or two additional steps to reach the ground or second floor, a standard track mounting should be used.

Pie-shaped landing (top & bottom)

In situations where both the top and bottom landings have pie shaped steps, the track should be extended all the way to the back wall at the top and rest on the first pie shaped step on the bottom.

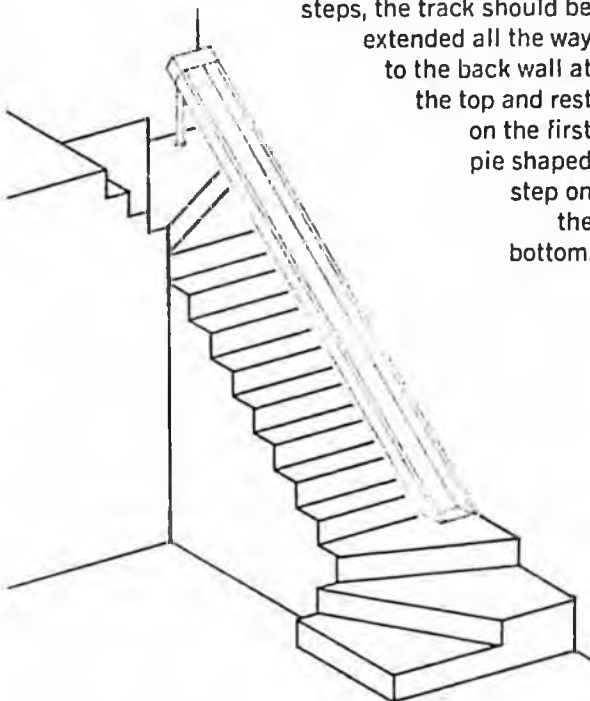

Double stairway with center landing (one STAIR-GLIDE[®])

Where a straight flight of stairs is interrupted by a middle landing and the customer doesn't wish to purchase two units, one for each set of stairs, a supporting brace can be constructed that would allow the use of one unit.

The track support can be made of such material as two 2" x 4" beams placed 13 inches apart, covered with 3/4" plywood, resting on the nose of each landing.

The amount of room necessary at the bottom landing for the track extension will be determined by the angle of the support.

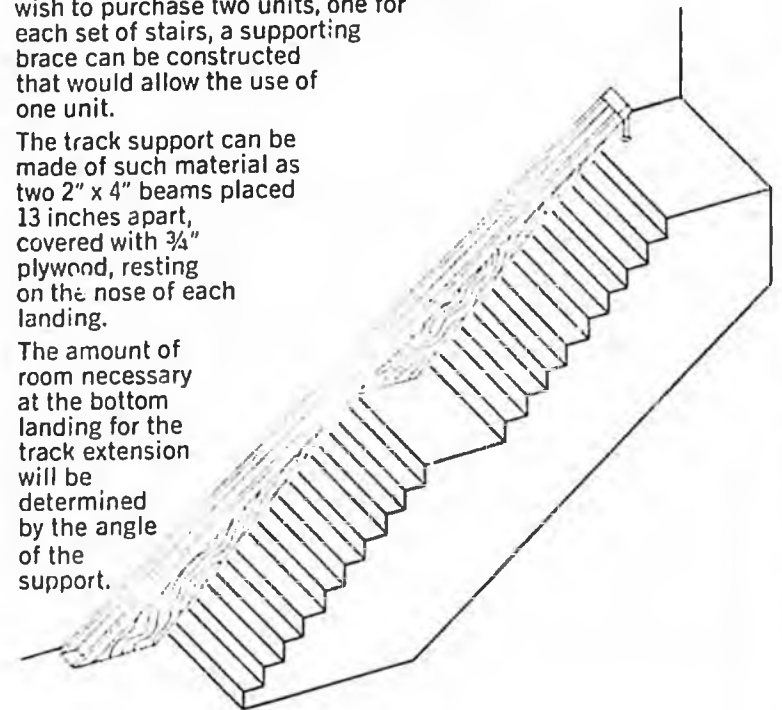

Double stairway with center landing (two STAIR-GLIDES®)

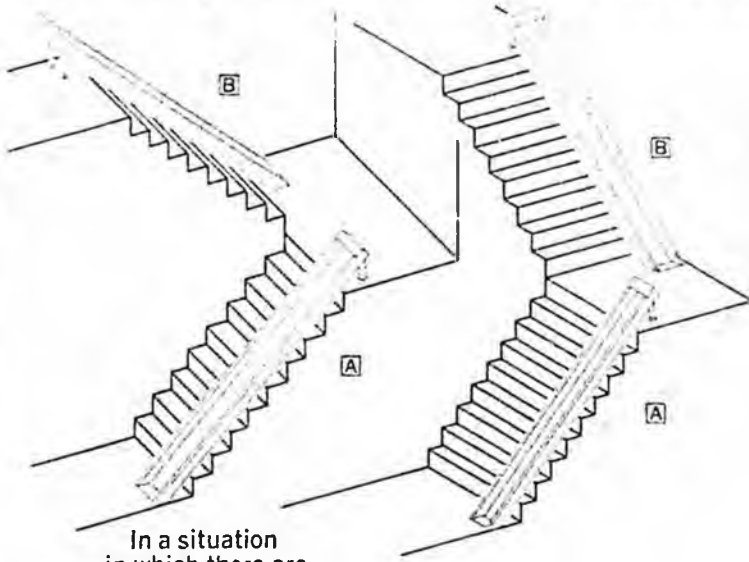

In a situation in which there are two separate flights of stairs, each with four or more steps, the installation can be handled very simply by installing two units. The rider will ascend on the first unit (A) to the middle landing where he rotates the seat a full 180° to get off the unit and transfers to the second unit (B) for continuation of the ride to the top landing. Consult your STAIR-GLIDE® dealer for information on the discount available when two units are purchased.

Double stairway with top landing extension

When there is a long lower flight of stairs, a middle landing which is either flat or contains pie shaped steps, and a shorter upper flight, and the physical condition of the rider will not allow him to climb the final steps to the top landing area, a platform or walkway can be constructed. The track would extend to the back wall and rest on the walkway which extends along the back wall level with the top landing or first step.

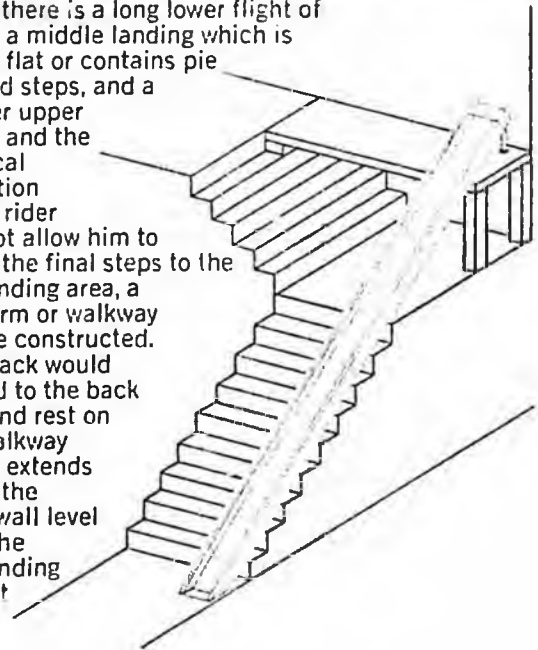

The rider can mount or dismount the unit on the walkway and will not be required to climb the last few steps.

Top obstruction

When there is a doorway or other obstruction at the top of the stairway which prohibits the normal top extension, the track would stop at the top landing and would be attached to the first step. The rider would mount and dismount on the first or second step from the top by rotating the seat 90°.

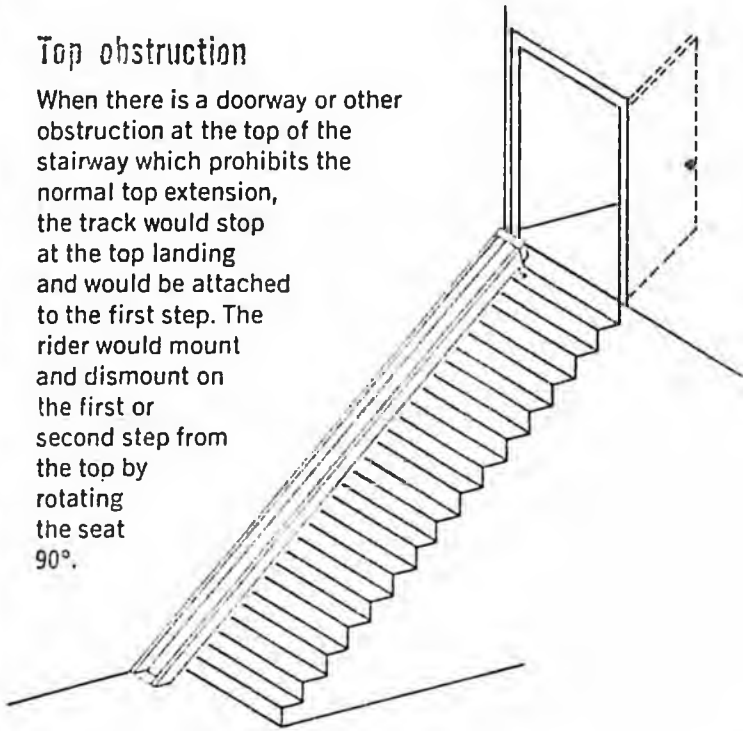

Bottom obstruction

When there is a door or passageway at the bottom of the stairs, it may be necessary to install a "step" or "bull nose" mounting plate. These mountings secure the track to the first step so it will not protrude into the bottom landing area and will not interfere with normal traffic or opening and closing of the door.

Consult your STAIR-GLIDE® dealer for more information on the special track mountings that are available.

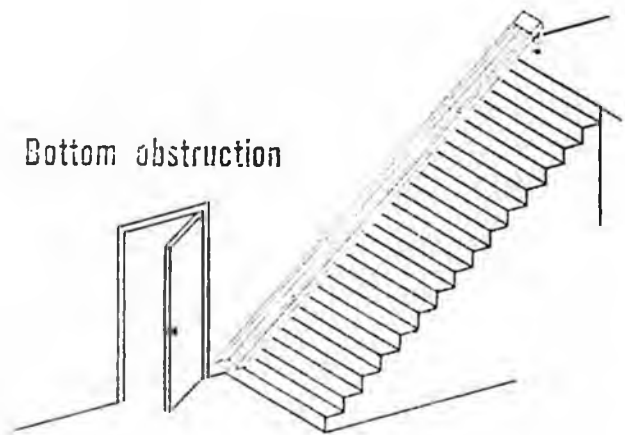

CAN SOMETHING THAT IS SO EASY TO OPERATE, BE A HIGH QUALITY PIECE OF EQUIPMENT, YOU ASK?

THE CHENEY COMPANY SAYS, YES, AND HERE'S WHY:

1. The Hydraulic motor and pump operate efficiently from the van battery with minimum current drain.
2. The lift folds completely inside permitting full use of van's inside capacity.
3. Semi-automatic model, as shown in this brochure requires an attendant to operate; fully automatic models are available complete with automatic door openers.
4. The platform, which can accommodate all wheelchair makes up to 500 lbs., is made of a grated material that is self-cleaning and does not obstruct vision through the windows fully.
5. While a van lift is primarily designed for 1971, 1972 and 1973 Dodge and Chevrolet vans, they are now being adapted to Fords and earlier van models.
6. These lifts can be installed in a matter of hours by the Cheney Company or its qualified representatives.



TRAVEL THE USA WITH A VAN LIFT TODAY!

That's not just our theme—it's also Mr. Leo Goebel's, pictured here with his mother and Mike Bruno of the Cheney Company.

Mr. Goebel had his Van Lift installed and two weeks later was vacationing in Florida.

DISTRIBUTED BY:

Also available: The Wecolator Stairway Elevator and Cheney Wheelchair Lift II.

THE CHENEY COMPANY

7811 NORTH 73RD STREET
MILWAUKEE, WISCONSIN 53223

414-354-8510

Travel the USA with a Van Lift today!
Picture yourself using this Van Lift...

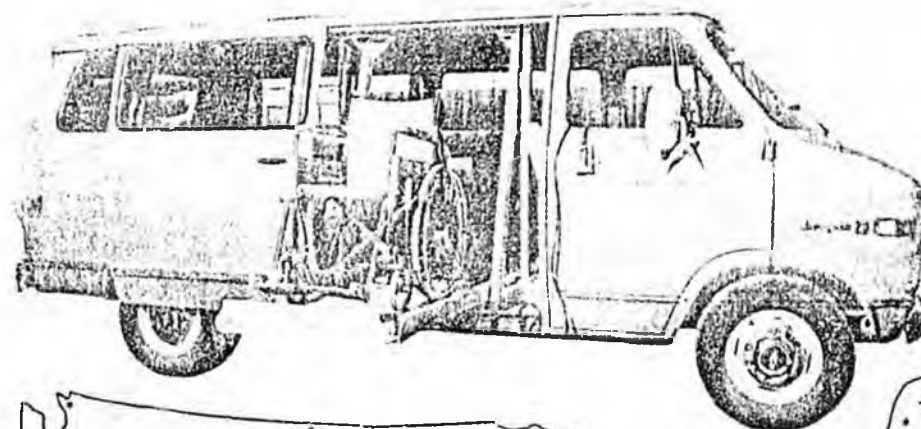

Sound
interesting?

Read on to ride on...

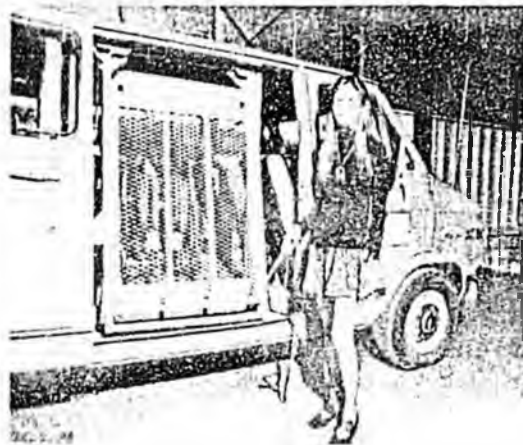

Easily Operated

A simple push of the button releases the safety locking feature that holds the lift securely in place.



In just three simple procedures, the passenger is now ready to use the platform. Please note the safety barrier feature at the end of the platform.

A firm grasp of the platform toward the operator, brings the platform into riding position.



Your riding companion easily lowers the platform by the touch of a button.



As you can see, it does not take a great deal of strength to fold down the platform.

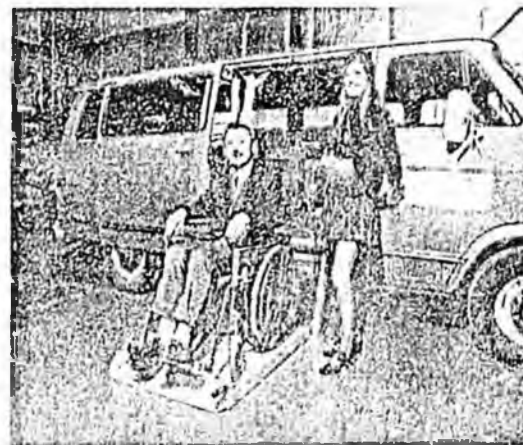

After reaching the ground, a lift of the handle releases the safety barrier and allows you to exit the platform.

Now...you're ready to go!



RECORDS CERTIFICATION

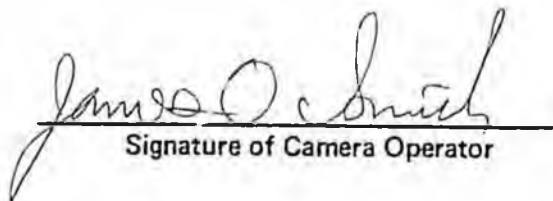

I, the undersigned, an employee of the State of Alaska, do hereby certify that the microfilm images on this microform are accurate reproductions of the original records of the State of Alaska as accumulated during the regular course of business, and that it is the established policy and practice of this State to microfilm its records and to dispose of the original records after microfilm reproductions have been made.

Signature of Camera Operator

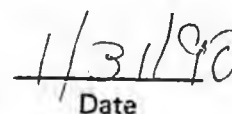
Date

"An Act relating to legislative per diem; and providing for an effective date."

COMMITTEE REPORT

2/27/75

HOUSE

RULES

Mr. Speaker:

Date _____

The Committee on Finance has had HB 226

under consideration. A Majority of the members of the Committee

recommends it DO PASS

recommends it DO NOT PASS

recommends it DO PASS WITH ATTACHED AMENDMENT(S)

recommends it BE REPLACED WITH CS FOR _____ AND THAT
CS FOR _____ DO PASS

"and" recommends it BE REFERRED TO THE _____
COMMITTEE

reports it back WITHOUT RECOMMENDATION

"other"

Members signing the Majority report:

Members NOT concurring in the Majority report:

_____ recommends:
_____ recommends:
_____ recommends:
_____ recommends:
_____ recommends:

Chairman

738

Introduced: 2/27/75
Referred: Finance and
Rules

1 IN THE HOUSE

BY WALLIS AND NAUGHTON

2 HOUSE BILL NO. 226

3 IN THE LEGISLATURE OF THE STATE OF ALASKA

4 NINTH LEGISLATURE - FIRST SESSION

5 A BILL

6 For an Act entitled: "An Act relating to legislative per diem; and provid-
7 ing for an effective date."

8 BE IT ENACTED BY THE LEGISLATURE OF THE STATE OF ALASKA:

9 * Section 1. AS 24.15.010 is amended to read:

10 Sec. 24.15.010. LEGISLATIVE PER DIEM. (a) The rate of per diem
11 instead of subsistence for each member of the legislature is \$43 [\$35]
12 for each day of a legislative session. The per diem is also payable
13 for those days of necessary travel to and from sessions.

14 (b) In addition to the per diem provided for in (a) of this
15 section, a member is entitled to receive an additional \$43 per diem
16 for each day he is required to travel away from the capital during
17 legislative sessions on official legislative business.

18 (c) A member who is required to travel on official legislative
19 business during the interim is entitled to \$43 per diem for the minimum
20 time required to get to and from meetings and while attending meetings
21 unless the meeting is in a location for which other state employees
22 are entitled to a higher rate. In that event the member is entitled
23 to the rate of per diem received by other state employees.

24 * Sec. 2. This Act takes effect July 1, 1975.
25
26
27
28
29

ALASKA STATE LEGISLATURE

1975 Legislature FIRST Session

HOUSE BILL NO. 226

By WALLIS AND NAUGHTON

An Act relating to legislative per diem; and providing for an effective date.

Leg. per diem

Introduced in the House 2/27, 19...75

HISTORY IN THE HOUSE

19 75

Feb 27

Read first time and referred to Committee on

Finance and Rules

Reported back with recommendation that

Read second time and

Read third time and

PASS Effective Date
Yeas Yeas
Nays Nays
Absent Absent
Excused Excused

Reconsideration

PASS Effective Date
Yeas Yeas
Nays Nays
Absent Absent
Excused Excused

Reported correctly engrossed
Signed by Speaker
Sent to Senate

CHIEF CLERK OF THE HOUSE

HISTORY IN THE SENATE

19

Read first time and referred to Committee on

Reported back with recommendation that

Read second time and

Read third time and

PASS Effective Date
Yeas Yeas
Nays Nays
Absent Absent
Excused Excused

Reconsideration

PASS Effective Date
Yeas Yeas
Nays Nays
Absent Absent
Excused Excused

Reported correctly engrossed
Signed by President
Returned to House

SECRETARY OF THE SENATE

HISTORY IN THE HOUSE

19

Received from Senate

Reported correctly enrolled

Sent to Governor

..... By Governor

Filed with Lt. Governor

Chapter No.

Introduced: 2/27/75
Referred: Finance and
Rules

1 IN THE HOUSE

BY WALLIS AND HAUGHTON

2 HOUSE BILL NO. 226

3 IN THE LEGISLATURE OF THE STATE OF ALASKA

4 NINTH LEGISLATURE - FIRST SESSION

5 A BILL

6 For an Act entitled: "An Act relating to legislative per diem; and provid-
7 ing for an effective date."

8 BE IT ENACTED BY THE LEGISLATURE OF THE STATE OF ALASKA:

9 * Section 1. AS 24.15.010 is amended to read:

10 Sec. 24.15.010. LEGISLATIVE PER DIEM. (a) The rate of per diem
11 Instead of subsistence for each member of the legislature is \$43 [~~\$35~~]
12 for each day of a legislative session. The per diem is also payable
13 for those days of necessary travel to and from sessions.

14 (b) In addition to the per diem provided for in (a) of this
15 section, a member is entitled to receive an additional \$43 per diem
16 for each day he is required to travel away from the capital during
17 legislative sessions on official legislative business.

18 (c) A member who is required to travel on official legislative
19 business during the interim is entitled to \$43 per diem for the minimum
20 time required to get to and from meetings and while attending meetings
21 unless the meeting is in a location for which other state employees
22 are entitled to a higher rate. In that event the member is entitled
23 to the rate of per diem received by other state employees.

24 * Sec. 2. This Act takes effect July 1, 1975.
25
26
27
28
29

Introduced: 2/27/75
Referred: Finance and
Rules

1 IN THE HOUSE

BY WALLIS AND NAUGHTON

2 HOUSE BILL NO. 226

3 IN THE LEGISLATURE OF THE STATE OF ALASKA

4 NINTH LEGISLATURE - FIRST SESSION

5 A BILL

6 For an Act entitled: "An Act relating to legislative per diem; and provid-
7 ing for an effective date."

8 BE IT ENACTED BY THE LEGISLATURE OF THE STATE OF ALASKA:

9 * Section 1. AS 24.15.010 is amended to read:

10 Sec. 24.15.010. LEGISLATIVE PER DIEM. (a) The rate of per diem
11 instead of subsistence for each member of the legislature is \$43 [\$35]
12 for each day of a legislative session. The per diem is also payable
13 for those days of necessary travel to and from sessions.

14 (b) In addition to the per diem provided for in (a) of this
15 section, a member is entitled to receive an additional \$43 per diem
16 for each day he is required to travel away from the capital during
17 legislative sessions on official legislative business.

18 (c) A member who is required to travel on official legislative
19 business during the interim is entitled to \$43 per diem for the minimum
20 time required to get to and from meetings and while attending meetings
21 unless the meeting is in a location for which other state employees
22 are entitled to a higher rate. In that event the member is entitled
23 to the rate of per diem received by other state employees.

24 * Sec. 2. This Act takes effect July 1, 1975.
25
26
27
28
29

Introduced: 2/27/75
Referred: Finance and
Rules

1 IN THE HOUSE

BY WALLIS AND NAUGHTON

2 HOUSE BILL NO. 226

3 IN THE LEGISLATURE OF THE STATE OF ALASKA

4 NINTH LEGISLATURE - FIRST SESSION

5 A BILL

6 For an Act entitled: "An Act relating to legislative per diem; and provid-
7 ing for an effective date."

8 BE IT ENACTED BY THE LEGISLATURE OF THE STATE OF ALASKA:

9 * Section 1. AS 24.15.010 is amended to read:

10 Sec. 24.15.010. LEGISLATIVE PER DIEM. (a) The rate of per diem
11 instead of subsistence for each member of the legislature is \$43 [~~\$35~~]
12 for each day of a legislative session. The per diem is also payable
13 for those days of necessary travel to and from sessions.

14 (b) In addition to the per diem provided for in (a) of this
15 section, a member is entitled to receive an additional \$43 per diem
16 for each day he is required to travel away from the capital during
17 legislative sessions on official legislative business.

18 (c) A member who is required to travel on official legislative
19 business during the interim is entitled to \$43 per diem for the minimum
20 time required to get to and from meetings and while attending meetings
21 unless the meeting is in a location for which other state employees
22 are entitled to a higher rate. In that event the member is entitled
23 to the rate of per diem received by other state employees.

24 * Sec. 2. This Act takes effect July 1, 1975.
25
26
27
28
29

The Legislature of the State of Alaska
FISCAL NOTE

First Session - Ninth Legislature

I. REQUEST

Bill No. HB 226
 Title: Legislative Per Diem
 Requested by: Rep. Naughton Date: 19 May 1975
 Return Date Requested: _____
 Agency: Legislative Affairs; Budget Program: Per Diem
& Audit Committee

II. FISCAL DETAIL

Budget Request Unit(s) Affected: _____
 A. EXPENDITURES: (Thousands of dollars)

OBJECT	FY 75	FY 76	FY 77	FY 78	FY 79	FY 80
100 PERSONAL SERVICES						
200 TRAVEL		48.6				
300 CONTRACTUAL						
400 COMMODITIES						
500 EQUIPMENT						
600 LAND & STRUCTURES						
700 GRANTS, CLAIMS, ETC.						
TOTAL		48.6				

B. FUNDING: (Thousands of dollars)

GENERAL FUND		48.6				
FEDERAL FUNDS						
OTHER						

C. POSITIONS: None

PERMANENT/TEMPORARY	/	/	/	/	/	/
MAN MONTHS (P./T.)	/	/	/	/	/	/

III. ANALYSIS (See Fiscal Note Preparation Instructions, Section III)

Legislature, Legislative Council Per Diem

In-Session FY 74 4983 member days @ \$35 = \$174,405*
 " FY 76 " " @ \$43 = 214,266

In-Session, Away From Capital
 FY 74 None
 FY 76 Est. 50 member days @ \$43 = 2,156

Interim FY 74 749 member days @ \$35 = 26,215
 FY 76 " " @ \$43 = 32,207
248,628

Budget and Audit Committee Per Diem

IV. ATTACHMENTS Interim FY 74 80 member days @ \$35 = 2,800
 FY 76 " " @ \$43 = 3,440
 Total \$6,240

Total Increase Over FY 74
 (\$252,066 - 203,420) 48,646

*Base data supplied by agency; fractional member days rounded to whole.

V. DATE: 19 May 1975 PREPARED BY: James B. Rhoads
 BA, House Finance Committee

Original: Legislative Finance
 cc: Budget and Management
 Prime Sponsor (First Legislator Named)



RECORDS CERTIFICATION

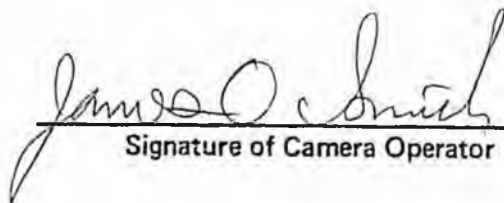

I, the undersigned, an employee of the State of Alaska, do hereby certify that the microfilm images on this microform are accurate reproductions of the original records of the State of Alaska as accumulated during the regular course of business, and that it is the established policy and practice of this State to microfilm its records and to dispose of the original records after microfilm reproductions have been made.

Signature of Camera Operator

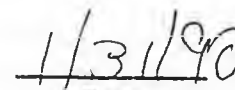
Date

"An Act relating to the senior citizens' municipal property tax exemption authorized under AS 29.53.020; and providing for an effective date."

COMMITTEE REPORT

3/6/75

HOUSE

Mr. Speaker:

Date

April 1, 1975

The Committee on FINANCE has had HB 227

under consideration. A Majority of the members of the Committee

recommends it DO PASS

recommends it DO NOT PASS

recommends it DO PASS WITH ATTACHED AMENDMENT(S)

recommends it BE REPLACED WITH CS FOR _____ AND THAT

CS FOR _____ DO PASS

"and" recommends it BE REFERRED TO THE _____

COMMITTEE

reports it back WITHOUT RECOMMENDATION

"other"

Members signing the Majority report:

Members NOT concurring in the Majority report:

_____ recommends:

_____ recommends:

_____ recommends:

_____ recommends:

_____ recommends:

H. Malone

Chairman

Introduced: 2/27/75
Referred: Community & Regional
Affairs and Finance

1 IN THE HOUSE

BY MALONE

2 HOUSE BILL NO. 227

3 IN THE LEGISLATURE OF THE STATE OF ALASKA

4 NINTH LEGISLATURE - FIRST SESSION

5 A BILL

6 For an Act entitled: "An Act relating to the senior citizens' municipal
7 property tax exemption authorized under AS 29.53.020;
8 and providing for an effective date."

9 BE IT ENACTED BY THE LEGISLATURE OF THE STATE OF ALASKA:

10 * Section 1. AS 29.53.020(f) is amended to read:

11 (f) No exemption may be granted except upon written application
12 for the exemption on a form prescribed by the state assessor for use
13 by local assessors. The claimant must file the application no later
14 than January 15 of the assessment year for which the exemption is
15 sought, but during the same year the governing body of the municipality
16 for good cause shown may waive the claimant's failure to make timely
17 application for the exemption for that year and authorize the assessor
18 to accept the application as if timely filed. The claimant [AND] must
19 file a separate application for each assessment year in which the
20 exemption is sought. If an application is filed within the required
21 time and is approved by the assessor, he shall allow an exemption in
22 accordance with the provisions of this section. If a claimant whose
23 failure to file by January 15 of the assessment year has been waived
24 as provided in this subsection and the application for exemption is
25 approved, the amount of tax, penalty, or interest which the claimant
26 may have already paid for the assessment year with respect to the
27 property exempted shall be refunded to him. The assessor may at any
28 time require proof in the form he considers necessary of the right and
29 amount of an exemption claimed under this section.

1 * Sec. 2. This Act takes effect immediately in accordance with AS 01.10.-
2 070(c).

3
4
5
6
7
8
9
10
11
12
13
14
15
16
17
18
19
20
21
22
23
24
25
26
27
28
29

The Legislature of the State of Alaska
FISCAL NOTE

First Session - Ninth Legislature

I. REQUEST

Bill No. HB 227

Title: ...Senior Citizens Municipal property tax exemption...

Requested by: House Finance

Date: March 6, 1975

Return Date Requested:

Agency: Community & Regional Affairs

Program: Social Services

II. FISCAL DETAIL

Budget Request Unit(s) Affected: Senior Citizens Property Tax Exemptions

A. EXPENDITURES: (Thousands of dollars)

OBJECT	FY 75	FY 76	FY 77	FY 78	FY 79	FY 80
100 PERSONAL SERVICES						
200 TRAVEL						
300 CONTRACTUAL						
400 COMMODITIES						
500 EQUIPMENT						
600 LAND & STRUCTURES						
700 GRANTS, CLAIMS, ETC.		36.4				
TOTAL		36.4				

B. FUNDING: (Thousands of dollars)

GENERAL FUND		36.4				
FEDERAL FUNDS						
OTHER						

C. POSITIONS:

PERMANENT/TEMPORARY	/	0	/	/	/	/
MAN MONTHS (P./T.)	/	/	/	/	/	/

III. ANALYSIS (See Fiscal Note Preparation Instructions, Section III)

- 1.) Percentage of applicants rejected due to late filing in FY'74 will hold true for the FY'76 program.
- 2.) Average rate of reimbursement per applicant is \$335.
- 3.) Percentage penalty on late payment of taxes is 10% and interest on late payment is 8%.
- 4.) Payment for back taxes, interest and penalties is limited to the fiscal year in which taxes were levied.

The estimated dollar figure for FY'76 is projected at the maximum amount required to fund late filed applications as extensive advertising campaigns at the local level have greatly increased public awareness of the program.

IV. ATTACHMENTS

V. DATE: March 14, 1975

PREPARED BY:



Robert Dozier
State Assessor
Local Gov't Assistance Division

Original: Legislative Finance
cc: Budget and Management
Prime Sponsor (First Legislator Named)



RECORDS CERTIFICATION



I, the undersigned, an employee of the State of Alaska, do hereby certify that the microfilm images on this microform are accurate reproductions of the original records of the State of Alaska as accumulated during the regular course of business, and that it is the established policy and practice of this State to microfilm its records and to dispose of the original records after microfilm reproductions have been made.

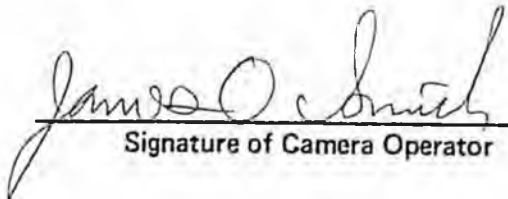

Signature of Camera Operator

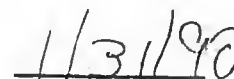

Date

"An Act making a special appropriation to the Department of Education for a study of the public school foundation program; and providing for an effective date."

COMMITTEE REPORT

4/25/75

HOUSE

Mr. Speaker:

Date _____

The Committee on FINANCE has had HB 229

under consideration. A Majority of the members of the Committee

recommends it DO PASS

recommends it DO NOT PASS

recommends it DO PASS WITH ATTACHED AMENDMENT(S)

recommends it BE REPLACED WITH CS FOR _____ AND THAT

CS FOR _____ DO PASS

"and" recommends it BE REFERRED TO THE _____

COMMITTEE

reports it back WITHOUT RECOMMENDATION

"other"

Members signing the Majority report:

_____	_____	_____
_____	_____	_____
_____	_____	_____
_____	_____	_____

Members NOT concurring in the Majority report:

_____ recommends:

_____ recommends:

_____ recommends:

_____ recommends:

_____ recommends:

_____ Chairman

"An Act making a special appropriation to the Department of Education for a study of the public school foundation program; and providing for an effective date."

COMMITTEE REPORT

2/27/75

HOUSE

FINANCE

Mr. Speaker:

Date April 24/75

The Committee on HESS has had ~~HB~~ HB 229

under consideration. ~~A Majority of the~~ members of the Committee

recommends it DO PASS

recommends it DO NOT PASS

recommends it DO PASS WITH ATTACHED AMENDMENT(S)

recommends it BE REPLACED WITH CS FOR HB 229 ^(new title) AND T-MAT.

CS FOR 229 DO PASS and report it back with individual recs.

"and" recommends it BE REFERRED TO THE _____

COMMITTEE

reports it back WITHOUT RECOMMENDATION

"other"

Members signing the Majority report:

① Jessie Sullivan Do pass } alumni letter back DO PASS ①
① John B. ... Do pass
② Nathaniel ... Do pass no recs.
① Charles H. ... Do Pass

Members NOT concurring in the Majority report:

③ Jessie Sullivan recommends: Do not pass
④ Stewart ... recommends: DO NOT PASS UNLESS AMEND
④ W. E. ... recommends: Do not pass unless am.
③ Al ... recommends: Do not pass

Jessie Sullivan Chairman

Original sponsor: Health, Education and
Social Services Committee

Offered: 4/25/75
Referred: Finance

1 IN THE HOUSE

BY THE HEALTH, EDUCATION AND
SOCIAL SERVICES COMMITTEE

2 CS FOR HOUSE BILL NO. 229

3 IN THE LEGISLATURE OF THE STATE OF ALASKA

4 NINTH LEGISLATURE - FIRST SESSION

5 A BILL

6 For an Act entitled: "An Act making a special appropriation to the Department
7 of Education for a study of quality, cost and financing
8 of pre-higher education; and providing for an effective
9 date."
10

11 BE IT ENACTED BY THE LEGISLATURE OF THE STATE OF ALASKA:

12 * Section 1. The sum of \$143,000 is appropriated from the general fund
13 to the Department of Education for the purpose of preparing a study of the
14 quality, cost and financing of pre-higher education.

15 * Sec. 2. The unexpended and unobligated portion of this appropriation
16 lapses into the general fund June 30, 1976.

17 * Sec. 3. This Act takes effect July 1, 1975.
18
19
20
21
22
23
24
25
26
27
28
29

753

Introduced: 2/27/75
Referred: Health, Education &
Social Services and Finance

BY THE HEALTH, EDUCATION AND
SOCIAL SERVICES COMMITTEE

1 IN THE HOUSE

2 HOUSE BILL NO. 229

3 IN THE LEGISLATURE OF THE STATE OF ALASKA

4 NINTH LEGISLATURE - FIRST SESSION

5 A BILL

6 For an Act entitled: "An Act making a special appropriation to the Depart-
7 ment of Education for a study of the public school
8 foundation program; and providing for an effective date."

9 BE IT ENACTED BY THE LEGISLATURE OF THE STATE OF ALASKA:

10 * Section 1. The sum of \$100,000 is appropriated from the general fund
11 to the Department of Education for a study of the public school foundation
12 program.

13 * Sec. 2. This Act takes effect July 1, 1975.
14
15
16
17
18
19
20
21
22
23
24
25
26
27
28
29

ALASKA STATE LEGISLATURE

NINTH Legislature FIRST Session

HOUSEBILL..... NO. ...229..

By THE HEALTH, EDUCATION AND SOCIAL SERVICES COMMITTEE

An Act making a special appropriation to the Department of Education for a study of the public school foundation program; and providing for an effective date."

Study-sch. found. program

Introduced in the House 2/27/1975

HISTORY IN THE HOUSE

19 75

Feb 27

Read first time and referred to Committee on

Health, Education & Social Services and Finance
Reported back with recommendation that

Read second time and

Read third time and

PASS	Effective Date
Yeas	Yeas
Nays	Nays
Absent	Absent
Excused	Excused

Reconsideration

PASS	Effective Date
Yeas	Yeas
Nays	Nays
Absent	Absent
Excused	Excused

Reported correctly engrossed
Signed by Speaker
Sent to Senate

CHIEF CLERK OF THE HOUSE

HISTORY IN THE SENATE

19

Read first time and referred to Committee on

Reported back with recommendation that

Read second time and

Read third time and

PASS	Effective Date
Yeas	Yeas
Nays	Nays
Absent	Absent
Excused	Excused

Reconsideration

PASS	Effective Date
Yeas	Yeas
Nays	Nays
Absent	Absent
Excused	Excused

Reported correctly engrossed
Signed by President
Returned to House

SECRETARY OF THE SENATE

HISTORY IN THE HOUSE

19

Received from Senate

Reported correctly enrolled

Sent to Governor

..... By Governor

Filed with Lt. Governor

Chapter No.

The Legislature of the State of Alaska
FISCAL NOTE

First Session - Ninth Legislature

I. REQUEST

Bill No. CSHB 229

Title: Making a special appropriation to the Dept. of Education

Requested by: House Finance Committee Date: 5/16/75

Return Date Requested: 5/16/75

Agency: Education Program: Executive Administration

II. FISCAL DETAIL

Budget Request Unit(s) Affected: Office of the Commissioner

A. EXPENDITURES: (Thousands of dollars)

OBJECT	FY 75	FY 76	FY 77	FY 78	FY 79	FY 80
100 PERSONAL SERVICES						
200 TRAVEL						
300 CONTRACTUAL		143,000				
400 COMMODITIES						
500 EQUIPMENT						
600 LAND & STRUCTURES						
700 GRANTS, CLAIMS, ETC.						
TOTAL		143,000	-0-	-0-	-0-	-0-

B. FUNDING: (Thousands of dollars)

GENERAL FUND		143,000				
FEDERAL FUNDS		-0-				
OTHER						

C. POSITIONS:

PERMANENT/TEMPORARY	/	/	/	/	/	/
MAN MONTHS (P./T.)	/	/	/	/	/	/

III. ANALYSIS (See Fiscal Note Preparation Instructions, Section III)

300 Contractual Services Estimated Expenditures

Personal Services	73,010
Travel	39,600
Contractual Services	27,900
Commodities	1,140
Equipment	1,350

IV. ATTACHMENTS

V. DATE: 5/19/75

PREPARED BY: William H. [Signature]

Original: Legislative Finance
cc: Budget and Management
Prime Sponsor (First Legislator Named)

The Legislature of the State of Alaska
FISCAL NOTE

First Session - Ninth Legislature

I. REQUEST

Bill No. CSHB 229

Title: Making a special appropriation to the Dept. of Education

Requested by: House Finance Committee Date: 5/16/75

Return Date Requested: 5/16/75

Agency: Education Program: Executive Administration

II. FISCAL DETAIL

Budget Request Unit(s) Affected: Office of the Commissioner

A. EXPENDITURES: (Thousands of dollars)

OBJECT	FY 75	FY 76	FY 77	FY 78	FY 79	FY 80
100 PERSONAL SERVICES						
200 TRAVEL						
300 CONTRACTUAL		143,000				
400 COMMODITIES						
500 EQUIPMENT						
600 LAND & STRUCTURES						
700 GRANTS, CLAIMS, ETC.						
TOTAL		143,000	-0-	-0-	-0-	-0-

B. FUNDING: (Thousands of dollars)

GENERAL FUND		143,000				
FEDERAL FUNDS		-0-				
OTHER						

C. POSITIONS:

PERMANENT/TEMPORARY	/	/	/	/	/	/
MAN MONTHS (P./T.)	/	/	/	/	/	/

III. ANALYSIS (See Fiscal Note Preparation Instructions, Section III)

300 Contractual Services Estimated Expenditures

Personal Services	73,010
Travel	39,600
Contractual Services	27,900
Commodities	1,140
Equipment	1,350

IV. ATTACHMENTS

V DATE: 5/14/75

PREPARED BY: William W. Thomas

Original: Legislative Finance
cc: Budget and Management
Prime Sponsor (First Legislator Named)

Introduced: 2/27/75
Referred: Health, Education &
Social Services and Finance

1 IN THE HOUSE

BY THE HEALTH, EDUCATION AND
SOCIAL SERVICES COMMITTEE

2 HOUSE BILL NO. 229

3 IN THE LEGISLATURE OF THE STATE OF ALASKA

4 NINTH LEGISLATURE - FIRST SESSION

5 A BILL

6 For an Act entitled: "An Act making a special appropriation to the Depart-
7 ment of Education for a study of the public school
8 foundation program; and providing for an effective date."

9 BE IT ENACTED BY THE LEGISLATURE OF THE STATE OF ALASKA:

10 * Section 1. The sum of \$100,000 is appropriated from the general fund
11 to the Department of Education for a study of the public school foundation
12 program.

13 * Sec. 2. This Act takes effect July 1, 1975.
14
15
16
17
18
19
20
21
22
23
24
25
26
27
28
29

#

Original sponsor: Health, Education and
Social Services Committee

Offered: 4/25/75
Referred: Finance

1 IN THE HOUSE

BY THE HEALTH, EDUCATION AND
SOCIAL SERVICES COMMITTEE

2 CS FOR HOUSE BILL NO. 229

3 IN THE LEGISLATURE OF THE STATE OF ALASKA

4 NINTH LEGISLATURE - FIRST SESSION

5 A BILL

6 For an Act entitled: "An Act making a special appropriation to the Department
7 of Education for a study of quality, cost and financing
8 of pre-higher education; and providing for an effective
9 date."

10 BE IT ENACTED BY THE LEGISLATURE OF THE STATE OF ALASKA:

11 * Section 1. The sum of \$143,000 is appropriated from the general fund
12 to the Department of Education for the purpose of preparing a study of the
13 quality, cost and financing of pre-higher education.

14 * Sec. 2. The unexpended and unobligated portion of this appropriation
15 lapses into the general fund June 30, 1976.

16 * Sec. 3. This Act takes effect July 1, 1975.
17
18
19
20
21
22
23
24
25
26
27
28
29

#



RECORDS CERTIFICATION

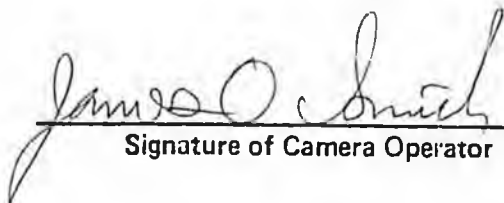

I, the undersigned, an employee of the State of Alaska, do hereby certify that the microfilm images on this microform are accurate reproductions of the original records of the State of Alaska as accumulated during the regular course of business, and that it is the established policy and practice of this State to microfilm its records and to dispose of the original records after microfilm reproductions have been made.

Signature of Camera Operator

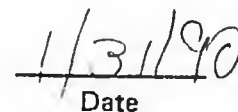
Date

"An Act making a special appropriation to the Department of Natural Resources for camping facilities in the Nancy Lake Recreation Area; and providing for an effective date."

COMMITTEE REPORT

3/31/75

HOUSE

Mr. Speaker:

Date March 31, 1975

The Committee on FINANCE has had HB 231

under consideration. A Majority of the members of the Committee

recommends it DO PASS

recommends it DO NOT PASS

recommends it DO PASS WITH ATTACHED AMENDMENT(S)

recommends it BE REPLACED WITH CS FOR _____ AND THAT

CS FOR HB 231 DO PASS

"and" recommends it BE REFERRED TO THE _____

COMMITTEE

reports it back WITHOUT RECOMMENDATION

"other"

Members signing the Majority report:

<u>[Signature]</u>	<u>[Signature]</u>	_____
<u>[Signature]</u>	<u>[Signature]</u>	_____
<u>[Signature]</u>	<u>[Signature]</u>	_____
<u>[Signature]</u>	<u>[Signature]</u>	_____

Members NOT concurring in the Majority report:

_____ recommends:

_____ recommends:

_____ recommends:

_____ recommends:

_____ recommends:

[Signature] Chairman

Humphrey

Original sponsor: Smith and Bradner

1 IN THE HOUSE BY THE FINANCE COMMITTEE
 2 CS FOR HOUSE BILL NO. 231
 3 IN THE LEGISLATURE OF THE STATE OF ALASKA
 4 NINTH LEGISLATURE - SECOND SESSION
 5 A BILL

6 For an Act entitled: "An Act making a special appropriation to the Depart-
 7 ment of Natural Resources for camping facilities in the
 8 Nancy Lake Recreation Area; and providing for an effec-
 9 tive date."

10 BE IT ENACTED BY THE LEGISLATURE OF THE STATE OF ALASKA:

11 * Section 1. The sum of \$10,000 is appropriated from the general fund to
 12 the Department of Natural Resources for advance planning of group camp facili-
 13 ties capable of accommodating handicapped persons in the Nancy Lake Recreation
 14 Area.

15 * Sec. 2. The sum of \$90,000 is appropriated from the general fund and
 16 the sum of \$100,000 is appropriated from anticipated receipts to the Depart-
 17 ment of Natural Resources for the development of group camp facilities
 18 capable of accommodating handicapped persons in the Nancy Lake Recreation
 19 Area. If nonstate receipts are not available for appropriation under this
 20 section by June 30, 1977, the appropriation of \$90,000 and the unexpended
 21 and unobligated portion of the \$10,000 appropriation lapse on that date.

22 * Sec. 3. Section 1 of this Act takes effect immediately in accordance
 23 with AS 01.10.070(c).

24 * Sec. 4. Section 2 of this Act takes effect July 1, 1976.
 25
 26
 27
 28
 29

Handwritten signature and date
 9/15/76

Introduced: 2/27/75
Referred: Health, Education &
Social Services and Finance

1 IN THE HOUSE

BY SMITH AND BRADNER

2 HOUSE BILL NO. 231

3 IN THE LEGISLATURE OF THE STATE OF ALASKA

4 NINTH LEGISLATURE - FIRST SESSION

5 A BILL

6 For an Act entitled: "An Act making a special appropriation to the Depart-
7 ment of Natural Resources for camping facilities in
8 the Nancy Lake Recreation Area; and providing for an
9 effective date."

10 BE IT ENACTED BY THE LEGISLATURE OF THE STATE OF ALASKA:

11 * Section 1. The sum of \$10,000 is appropriated from the general fund to
12 the Department of Natural Resources for advance planning of group camp facili-
13 ties capable of accommodating handicapped persons in the Nancy Lake Recreation
14 Area.

15 * Sec. 2. The sum of \$90,000 is appropriated from the general fund and
16 the sum of \$100,000 is appropriated from anticipated federal receipts to the
17 Department of Natural Resources for the development of group camp facilities
18 capable of accommodating handicapped persons in the Nancy Lake Recreation
19 Area. If federal receipts are not available for appropriation under this
20 section, by June 30, 1976, the appropriation of \$90,000 and the unexpended
21 and unobligated portion of the \$10,000 appropriation lapse on that date.

22 * Sec. 3. Section 1 of this Act takes effect immediately in accordance
23 with AS 01.10.070(c).

24 * Sec. 4. Section 2 of this Act takes effect July 1, 1975.
25
26
27
28
29

THE LEGISLATURE OF THE STATE OF ALASKA
FISCAL NOTE
Second Session - Ninth Legislature

I. REQUEST

Bill No. HB 231

Title: Special Appropriation...Camping Facilities...Nancy Lake Recreation Area

Requested by: House Finance Comm.

Date: 2/23/76

Return Date Requested:

Agency: Division of Parks

Program: Parks and Recreation

II. FISCAL DETAIL

Budget Request Unit(s) Affected: Parks and Recreation

A. EXPENDITURES: (Thousands of dollars)

OBJECT	FY 76	FY 77	FY 78	FY 79	FY 80	FY 81
100 PERSONAL SERVICES		5.0	5.0	9.0	18.0	28.0
200 TRAVEL		1.5				
300 CONTRACTUAL		138.0	150.0	220.0	158.0	8.4
400 COMMODITIES		54.0	50.0	80.0	2.1	2.2
500 EQUIPMENT		1.5				
600 LAND & STRUCTURES						
700 GRANTS, CLAIMS, ETC.						
TOTAL		200.0	255.0	309.0	178.1	38.6

B. FUNDING: (Thousands of dollars)

GENERAL FUND		100.0	105.0	209.0	103.1	38.6
FEDERAL FUNDS		100.0	100.0	100.0	75.0	
OTHER						

C. POSITIONS:

PERMANENT/TEMPORARY	/	/ 1	/ 1	1 /	1 /	1 / 1
MAN HOURS (P./T.)	/	/ 3	/ 4	6 /	12 /	12 / 4

III. ANALYSIS (See Fiscal Note Preparation Instructions, Section III)

A camp area would be developed for non-standard campers with multi-type users over entire year. Perimeter campsite development would be standard. Project would include water and sewage programs, access road, facility construction of cabins and multi-purpose building to serve as activity center in inclement weather and a mess hall, and recreation trails and recreation stations (signing, boat docks, play areas, beaches).

IV. ATTACHMENTS

V. DATE: 2/25/76

PREPARED BY:

George A. Hall
George A. Hall, Deputy Director
Division of Parks

Original: Legislative Finance

cc: Budget and Management

Prime Sponsor (First Legislator Named)