

3/3/10

**PRESENTA-
TION:
MAKING
SENSE OF
ENERGY
EFFICIENCY**



Making \$ense of Energy Efficiency



Cary Bolling
AHFC Energy Specialist

Conservation vs. Efficiency

CONSERVATION	EFFICIENCY
Turn off lights	Use energy efficient lights
Lower thermostat	Programmable thermostat
Use less hot water	Install water heater blanket
Open refrigerator less	Use Energy Star refrigerator

Cutting Back vs. Doing More with Less

Product Purchase Decisions

Model	Screen size (diagonal)	Power consumption (in watts)			Estimated annual energy cost
		Power on	Standby	Per sq. inch (when on)	
Sharp LC-37D40U 	37 inches	177.25	1.19	0.30	\$54.55
Sharp LC-37D90U 	37 inches	218.74	40.04	0.37	\$90.75

Source: CNET's "54 TVs' power consumption compared"
 8hrs on. 16 hrs off @ 10.4 cents/kwh



For \$100

- 10 CFLS = 30.00
- 1.6 gpm showerhead = 12.00
- Water heater blanket = 20.00
- Door & window weatherstrip/caulk = 15.00
- Car block heater timer = 20.00
- Powerstrip = 3.00

APPROXIMATE ANNUAL SAVINGS

- 10 CFLS = 30.00
- 1.6 gpm showerhead = 12.00
- Water heater blanket = 20.00
- Door & window weatherstrip/caulk = 15.00
- Car block heater timer = 20.00
- Powerstrip = 3.00
- = 200.00 / year
- = 80.00+ / year
- = 10.00-30.00+ / year
- = 40.00+ / year
- = 200.00 / year
- = 100.00 / year

COST = 100.00

SAVINGS = 650.00 / year

HOME ENERGY USE

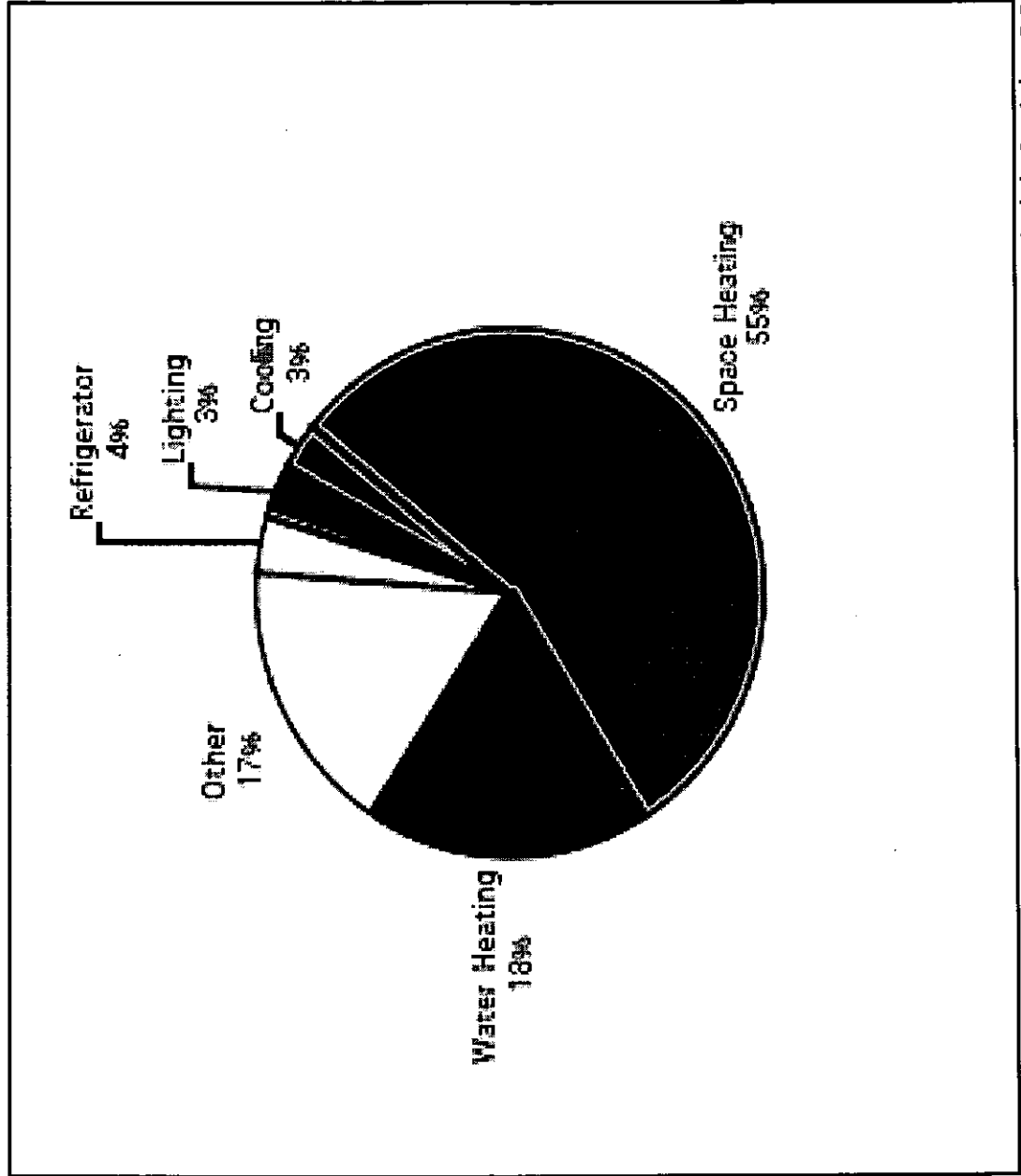

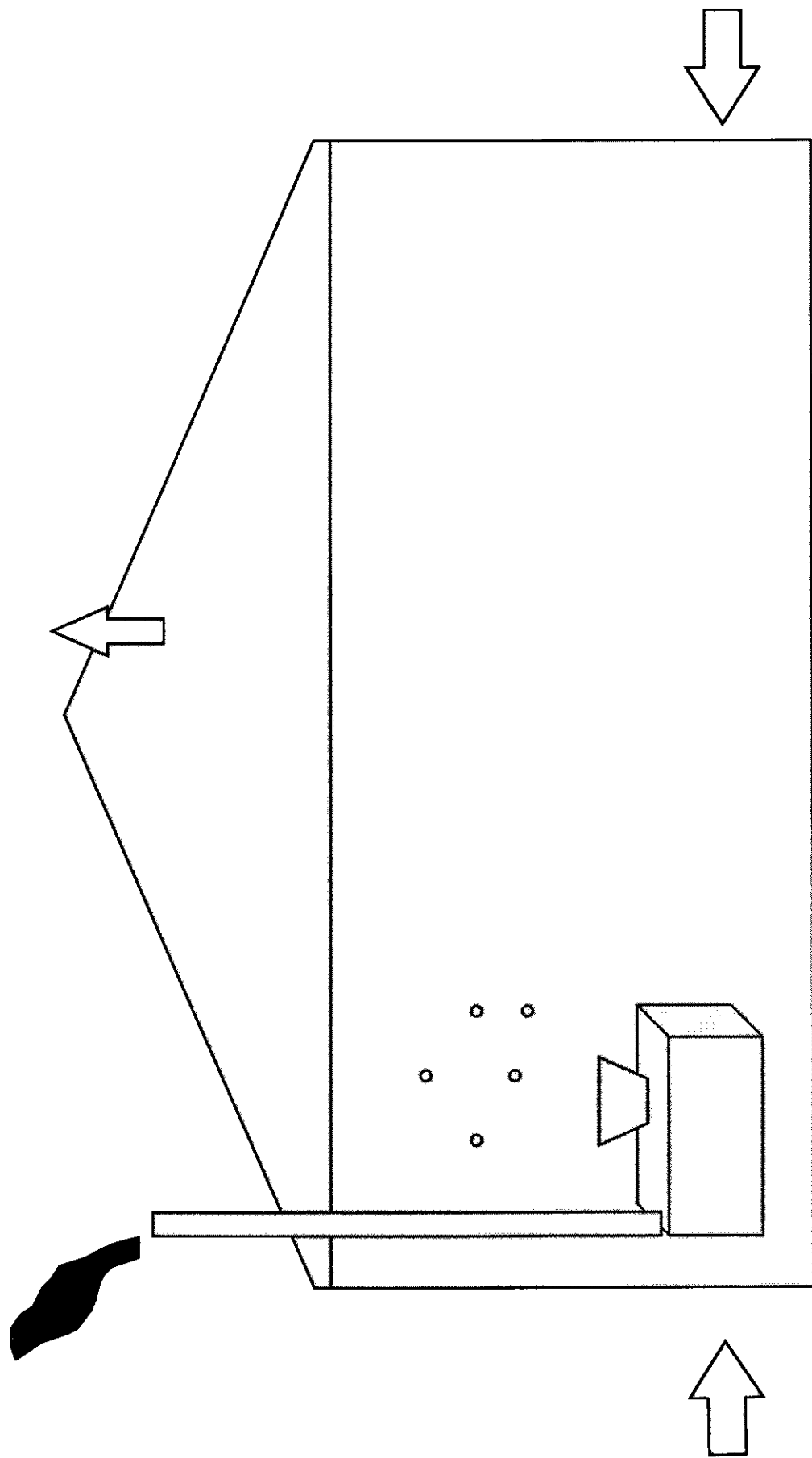

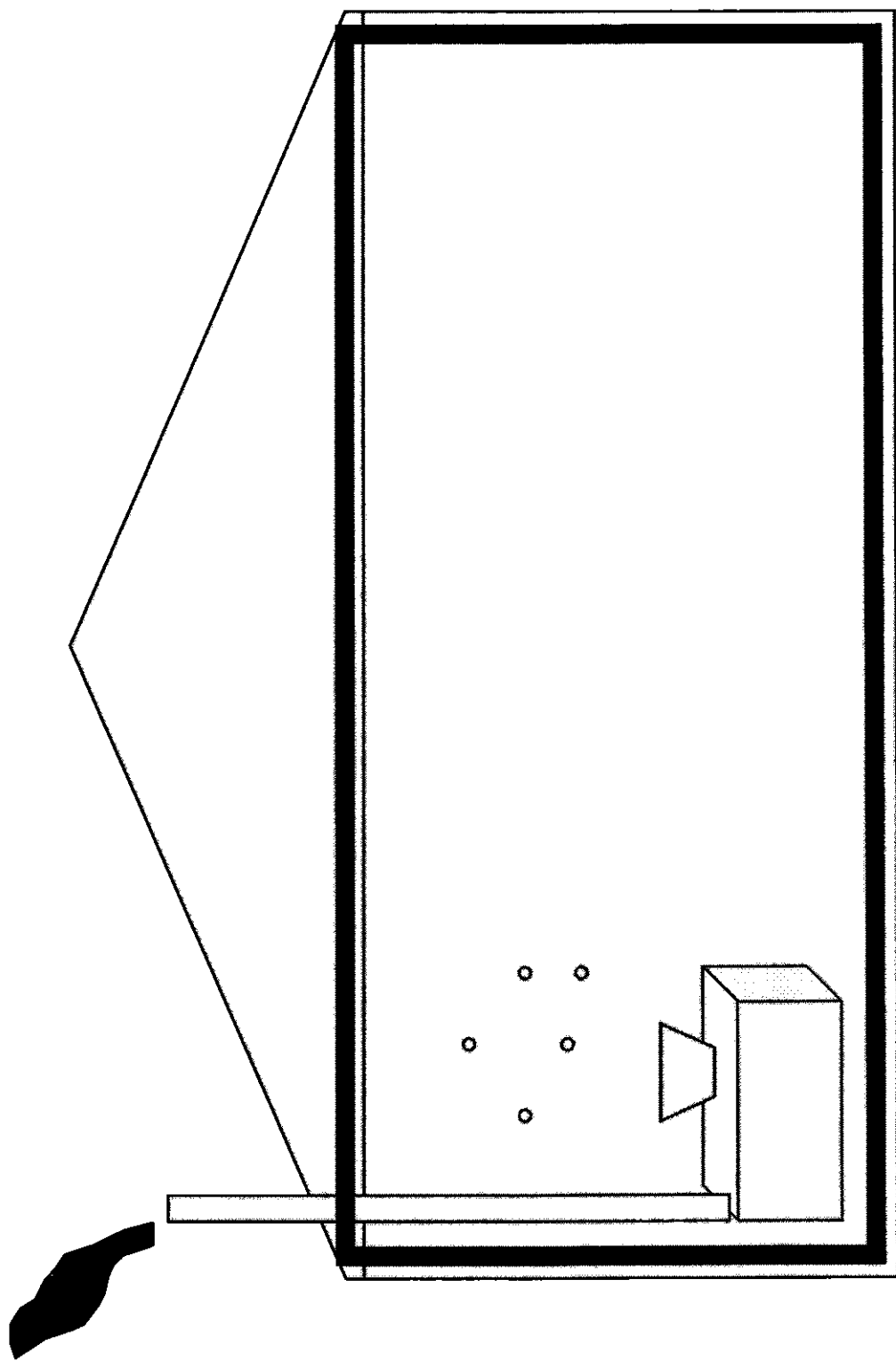

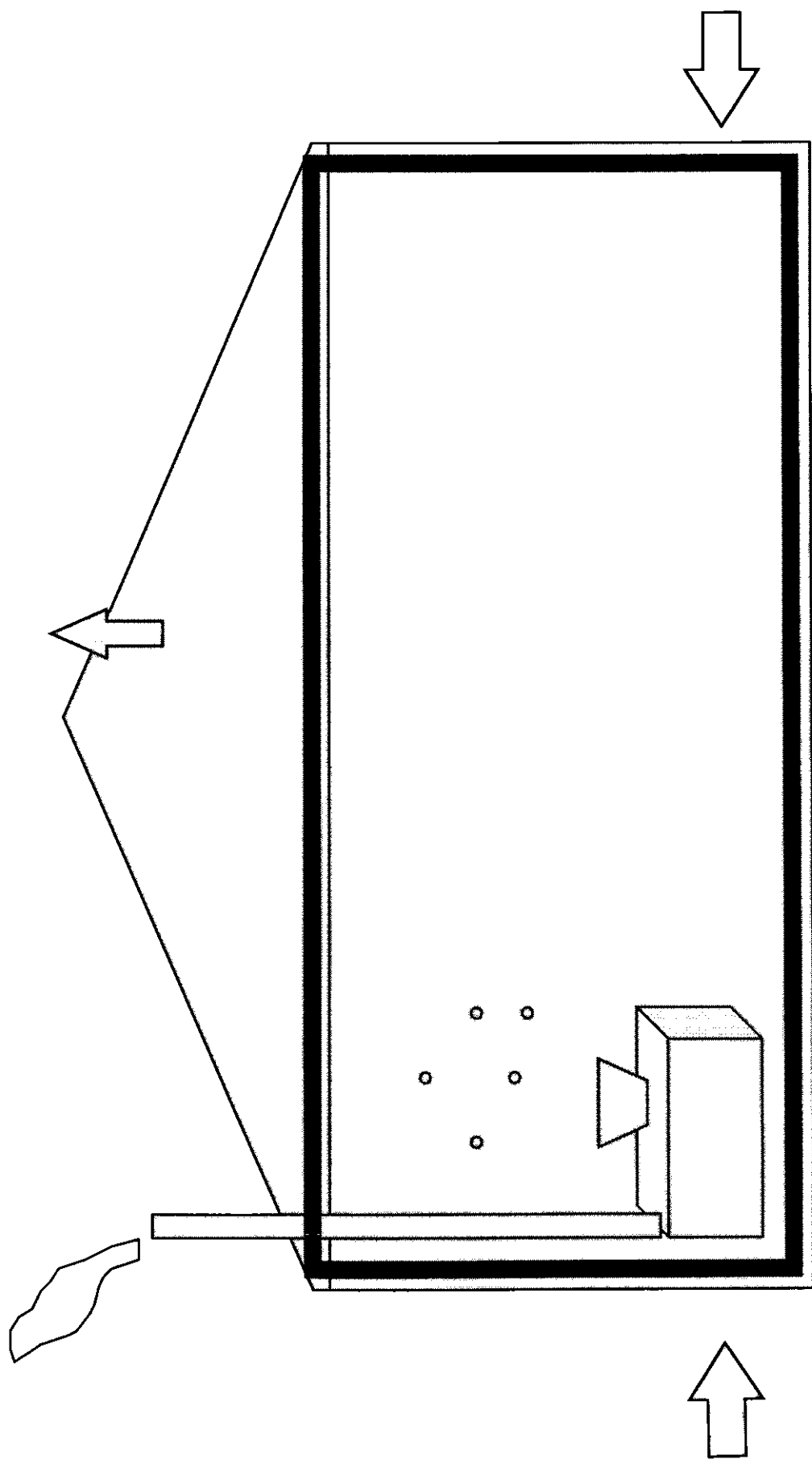

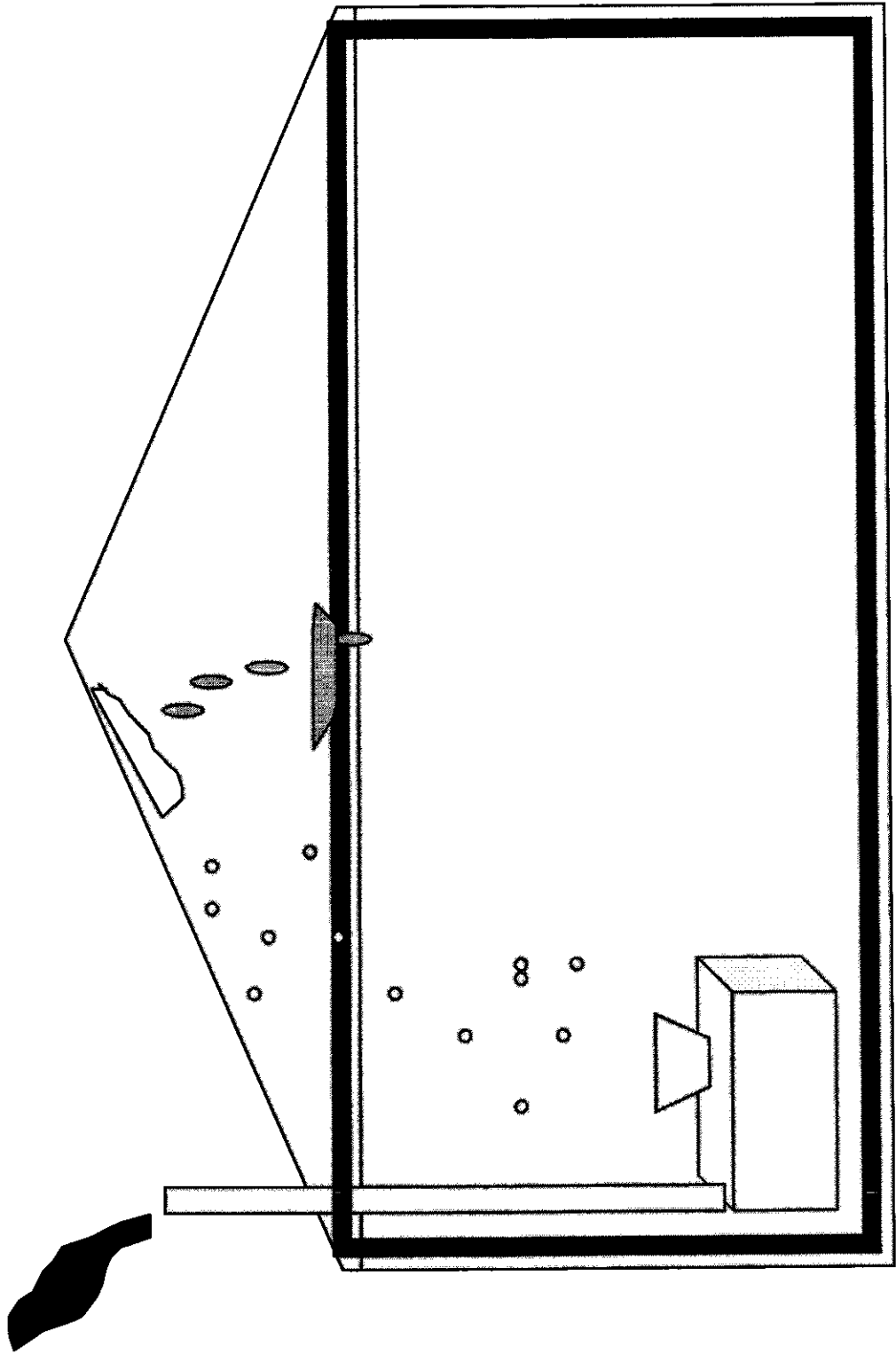





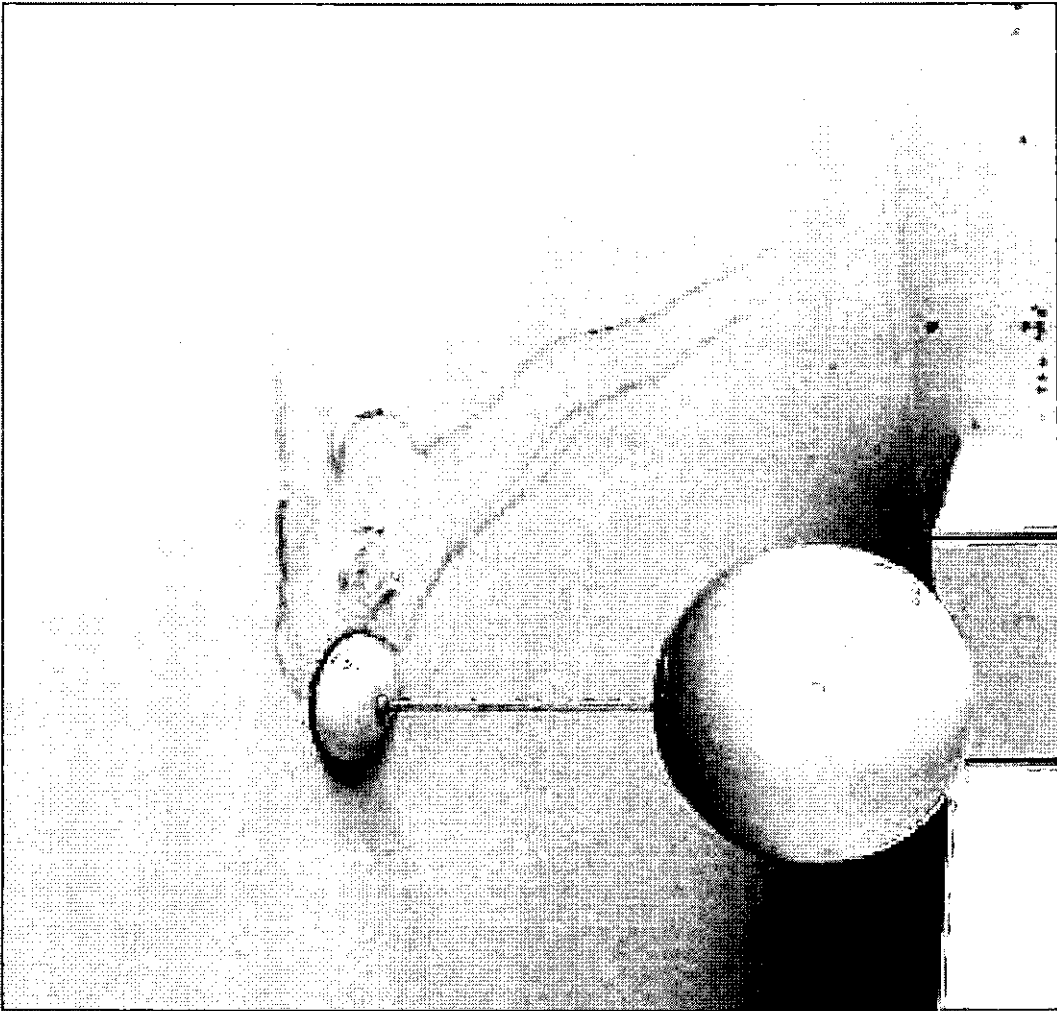

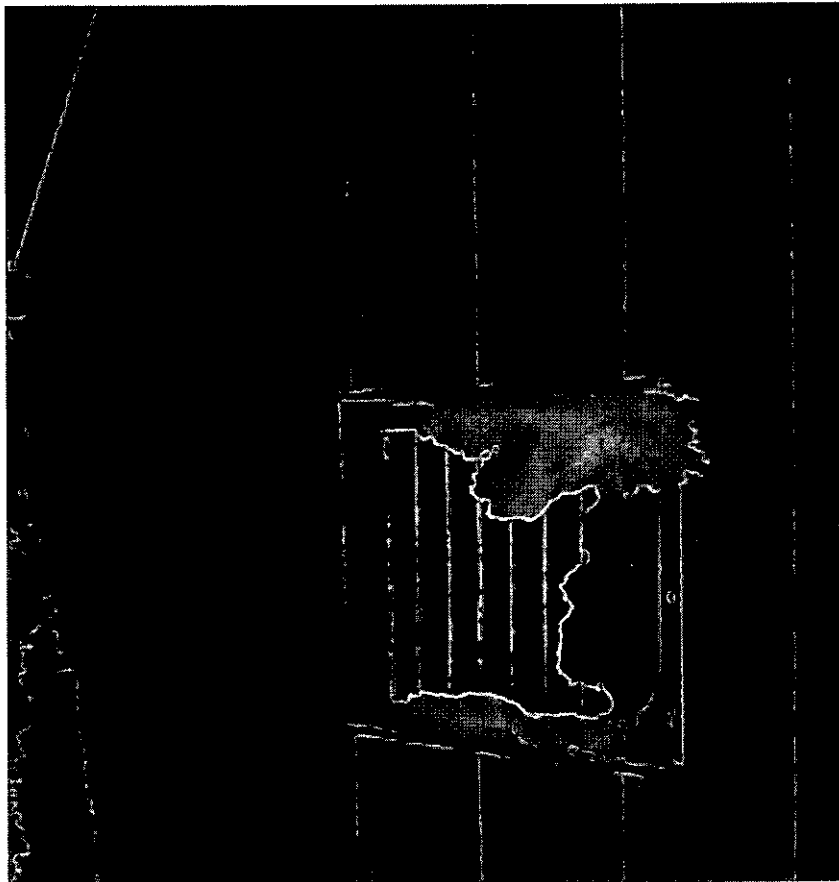



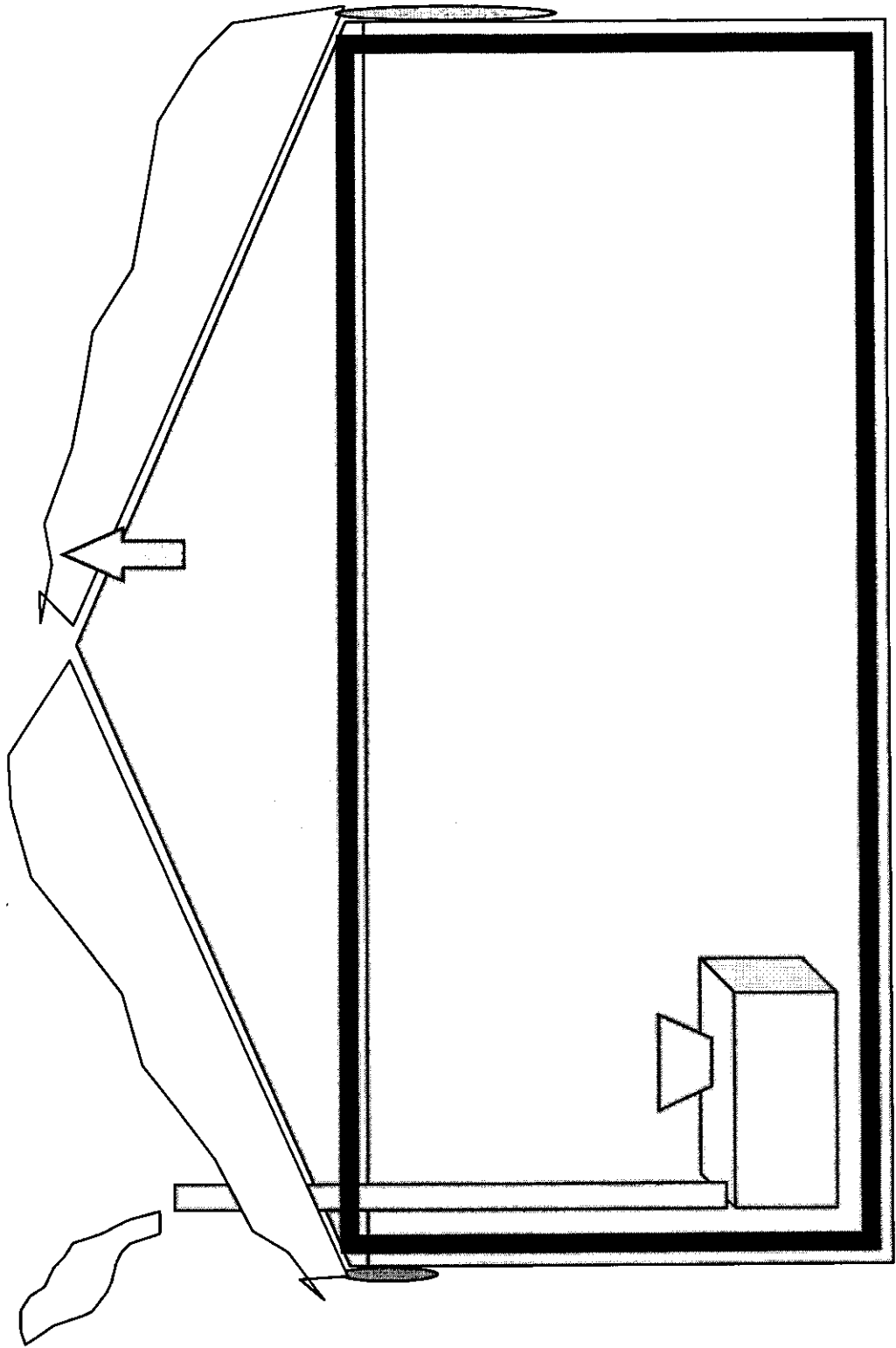

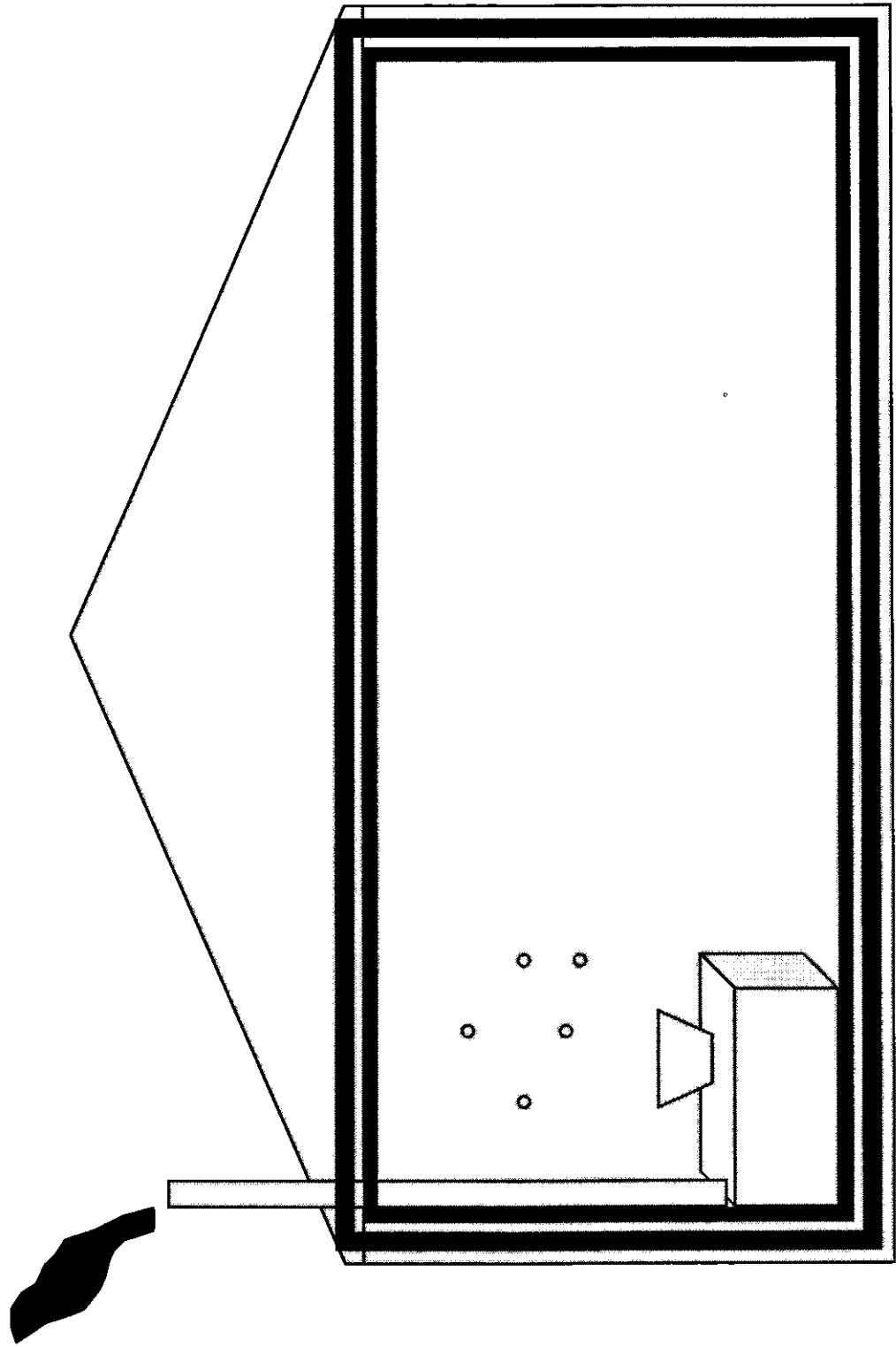

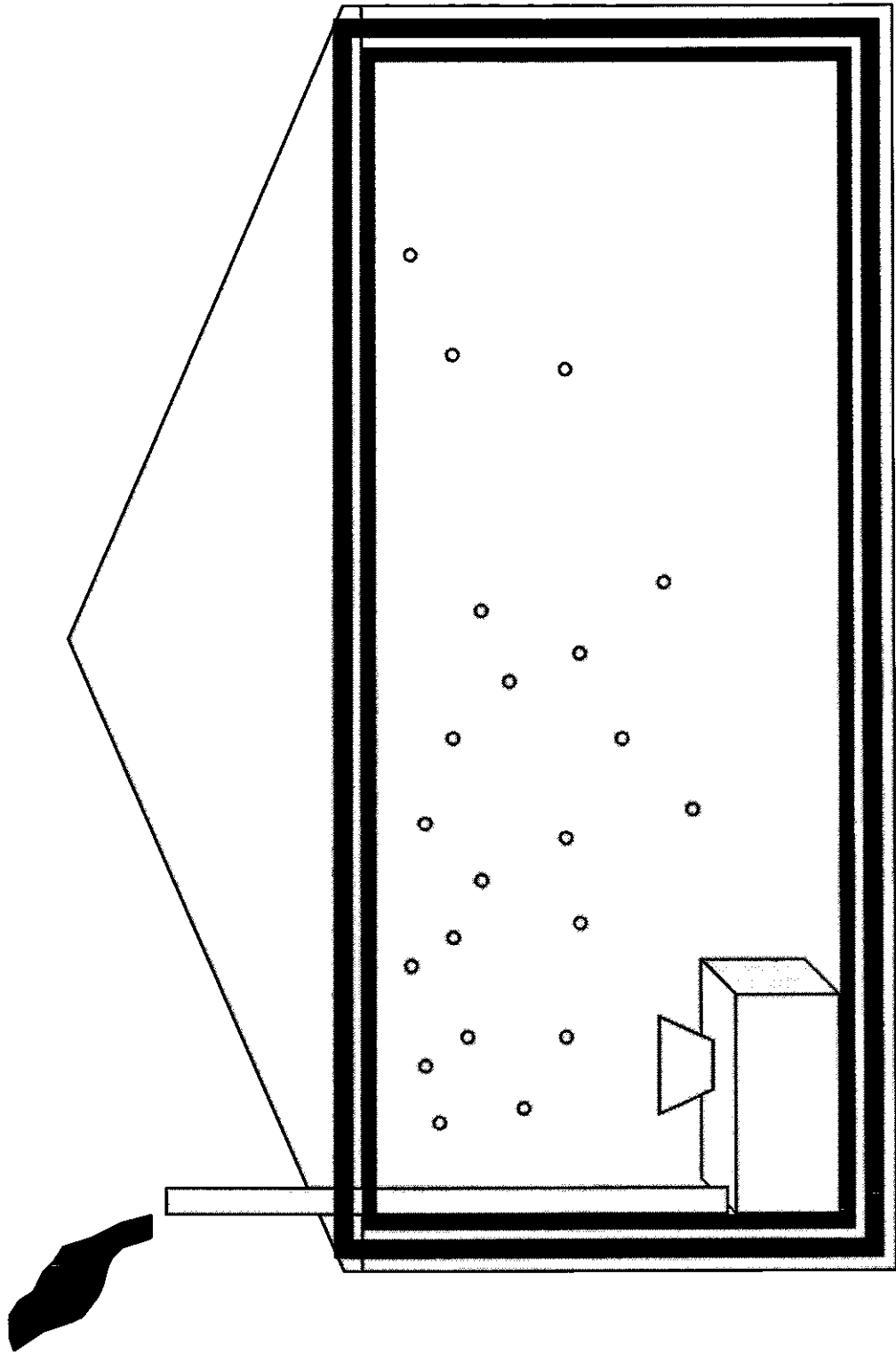

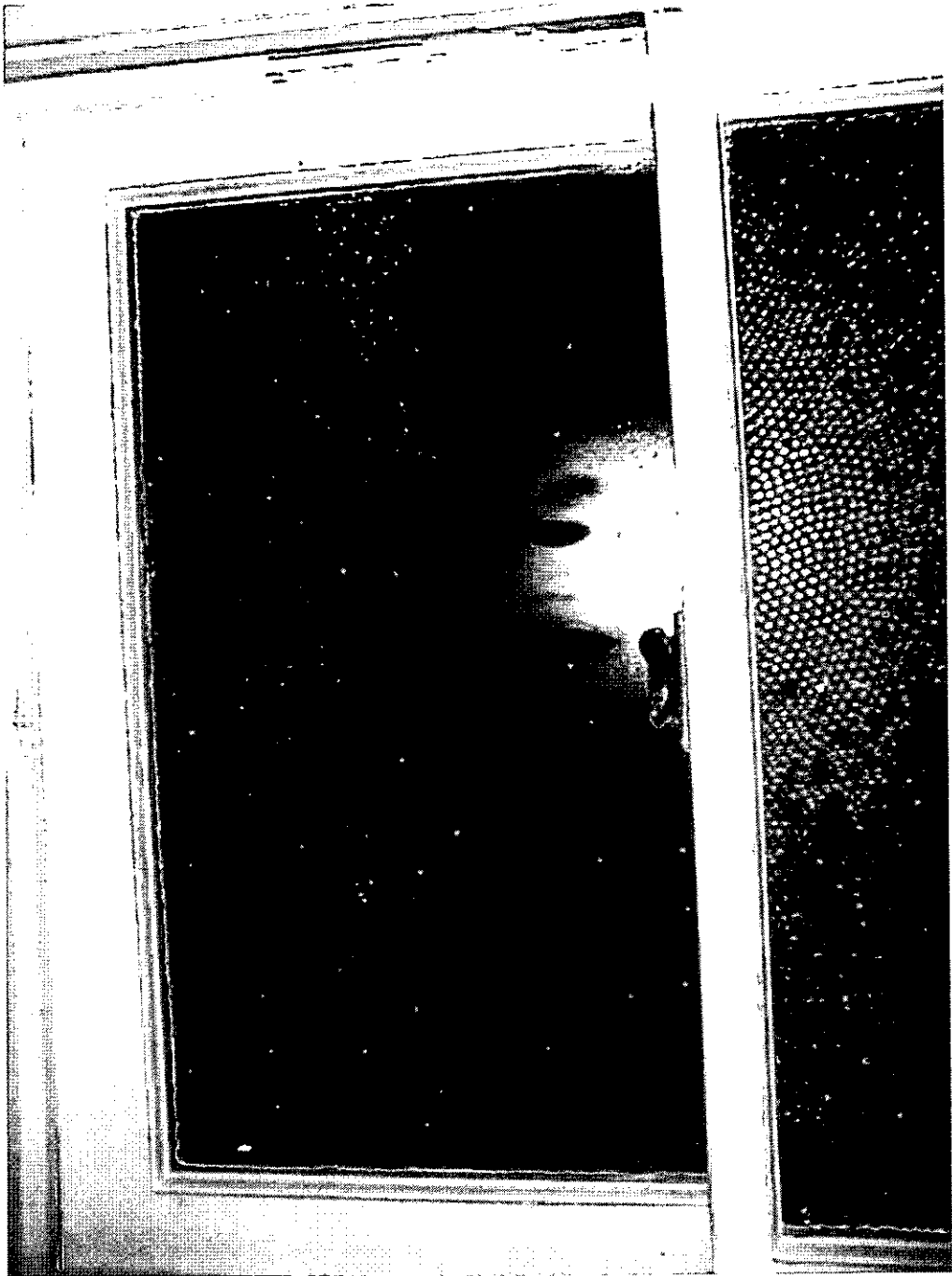



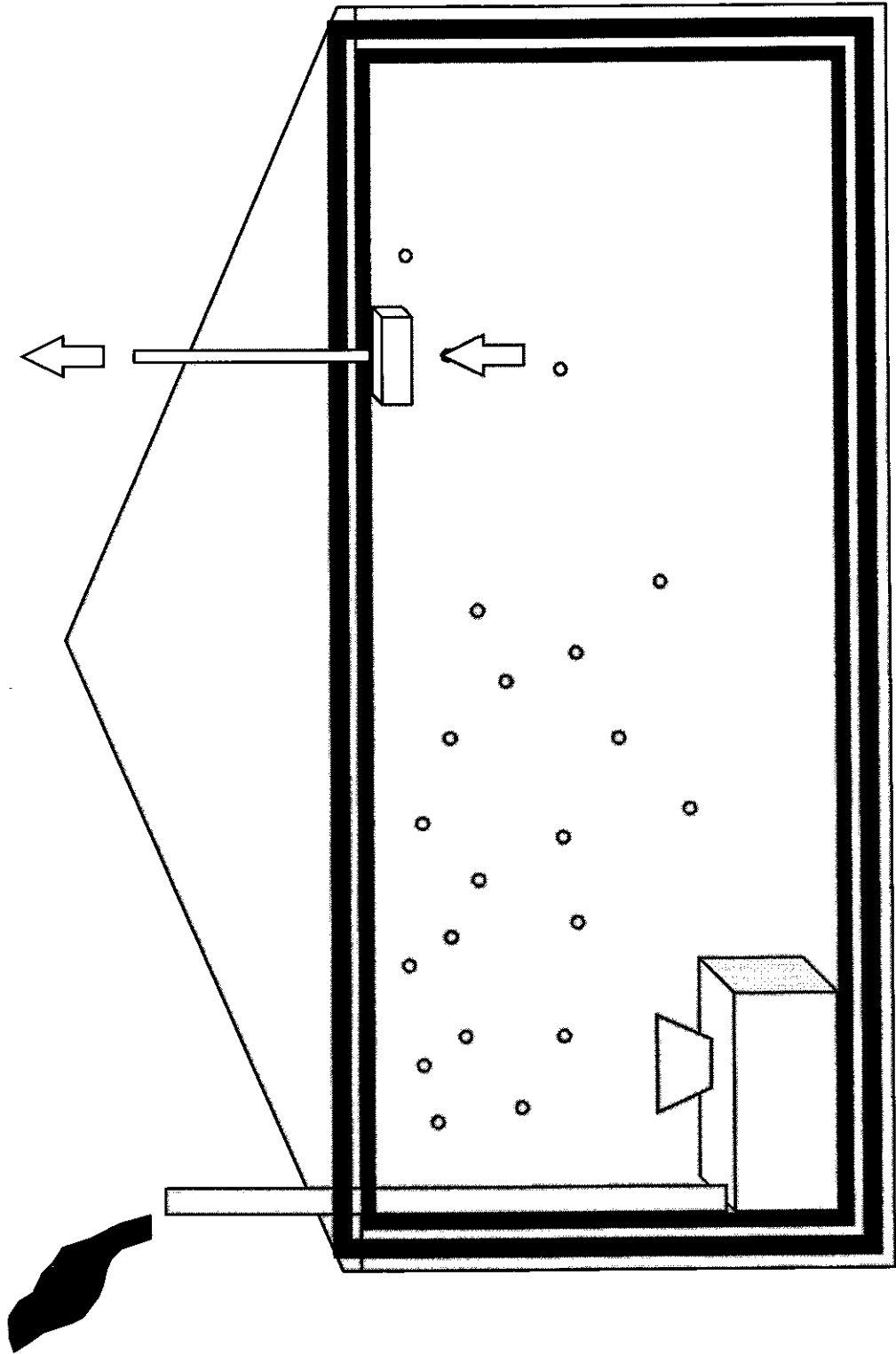

Ventilation System

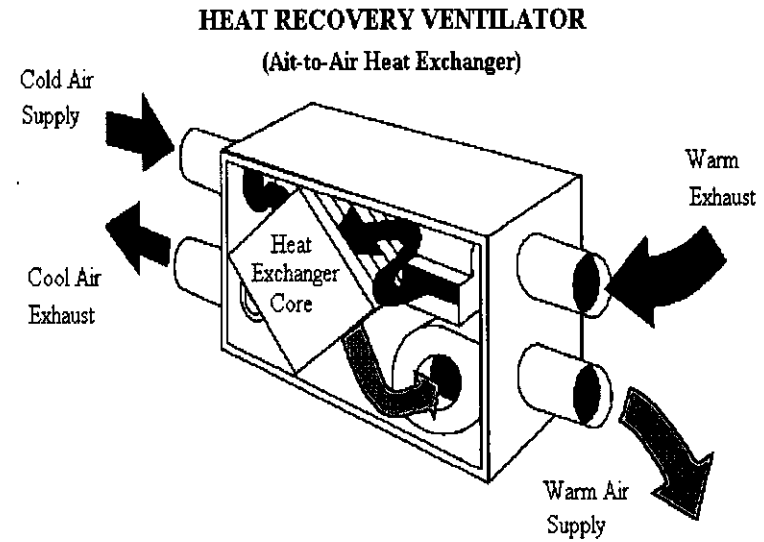
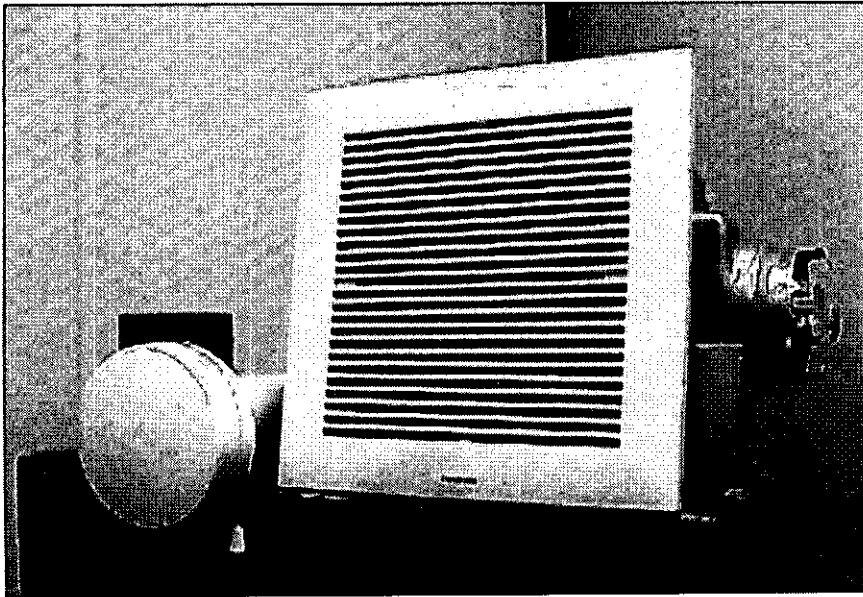

“Build tight, ventilate right”

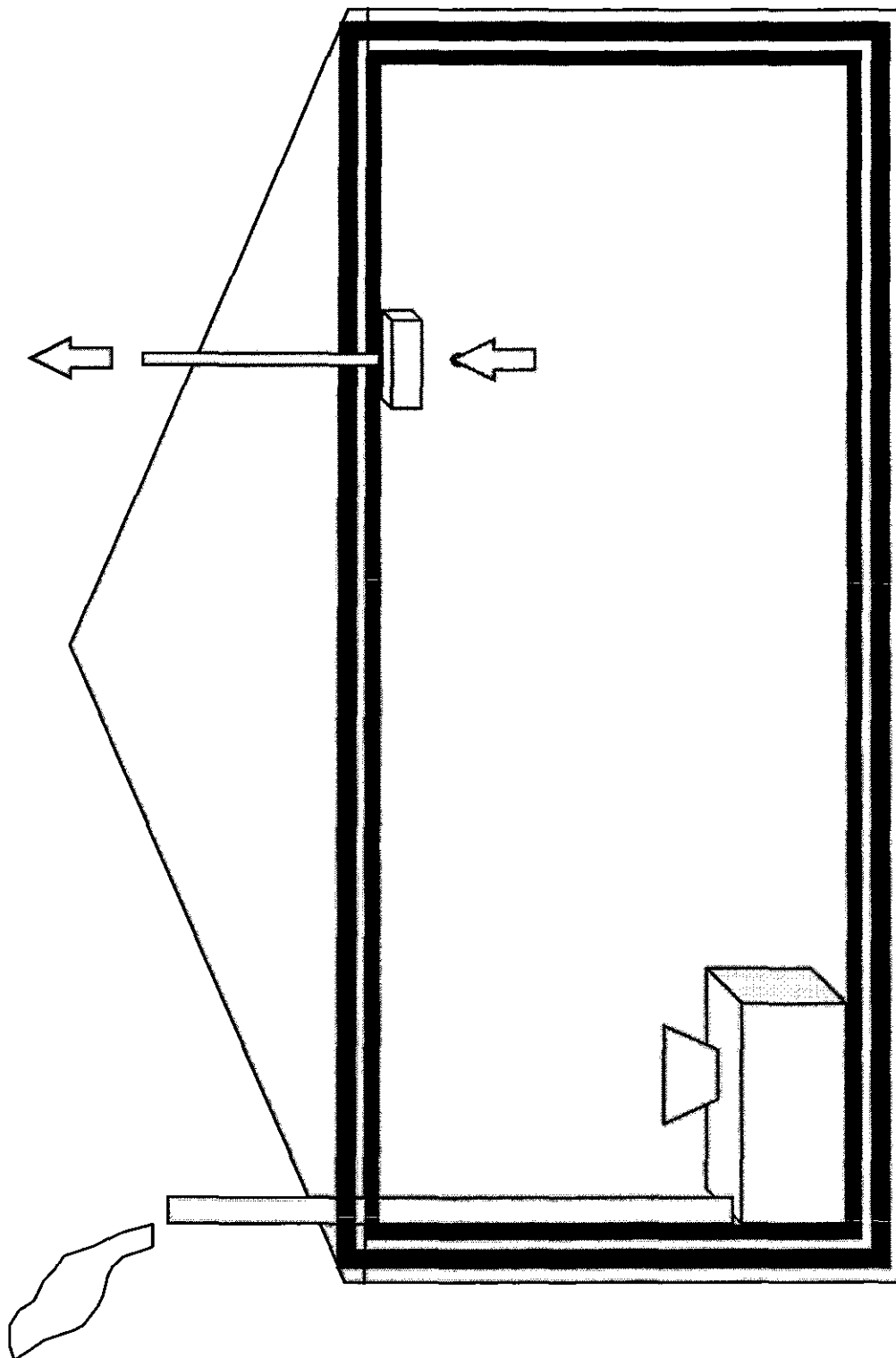

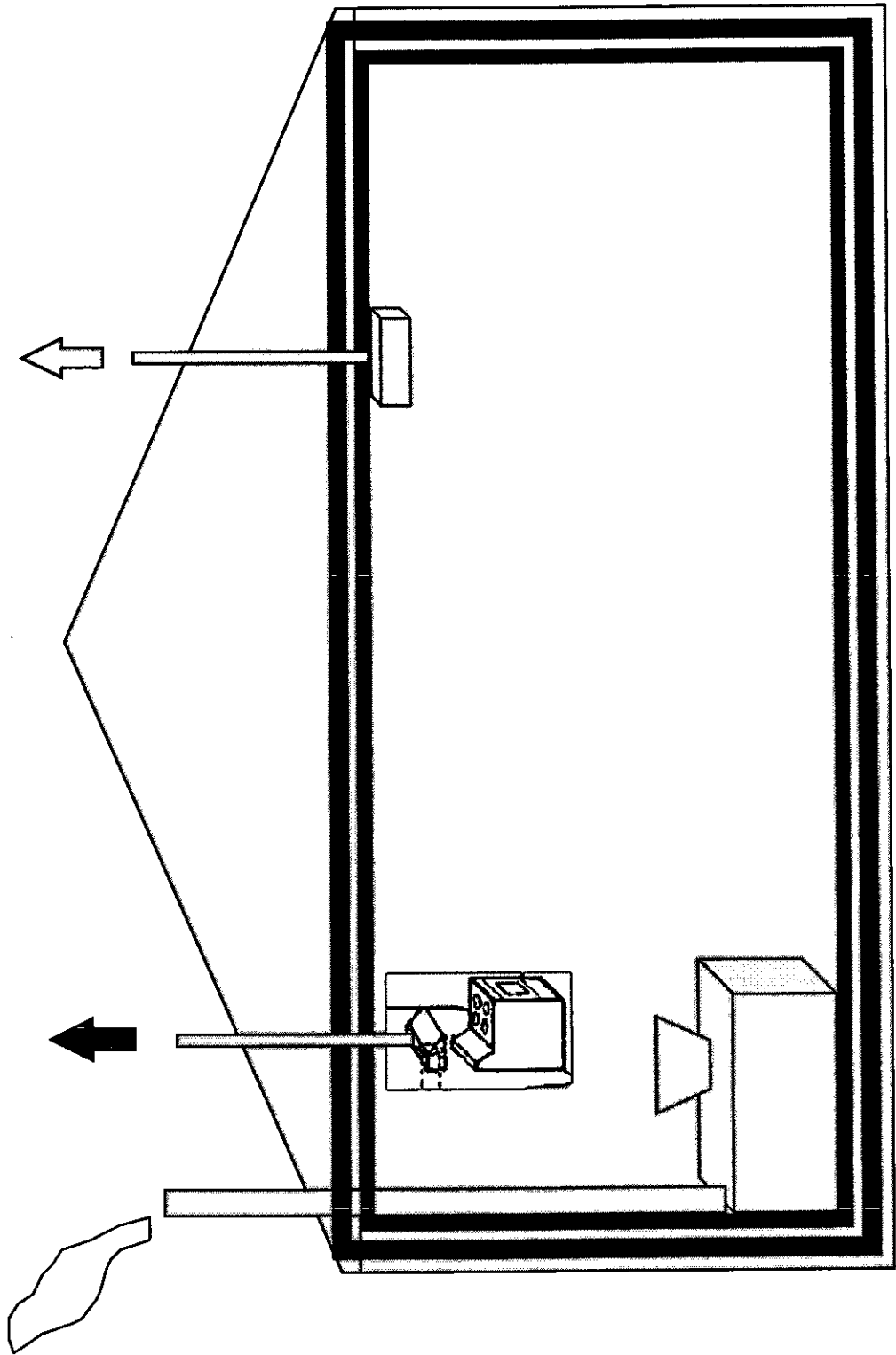

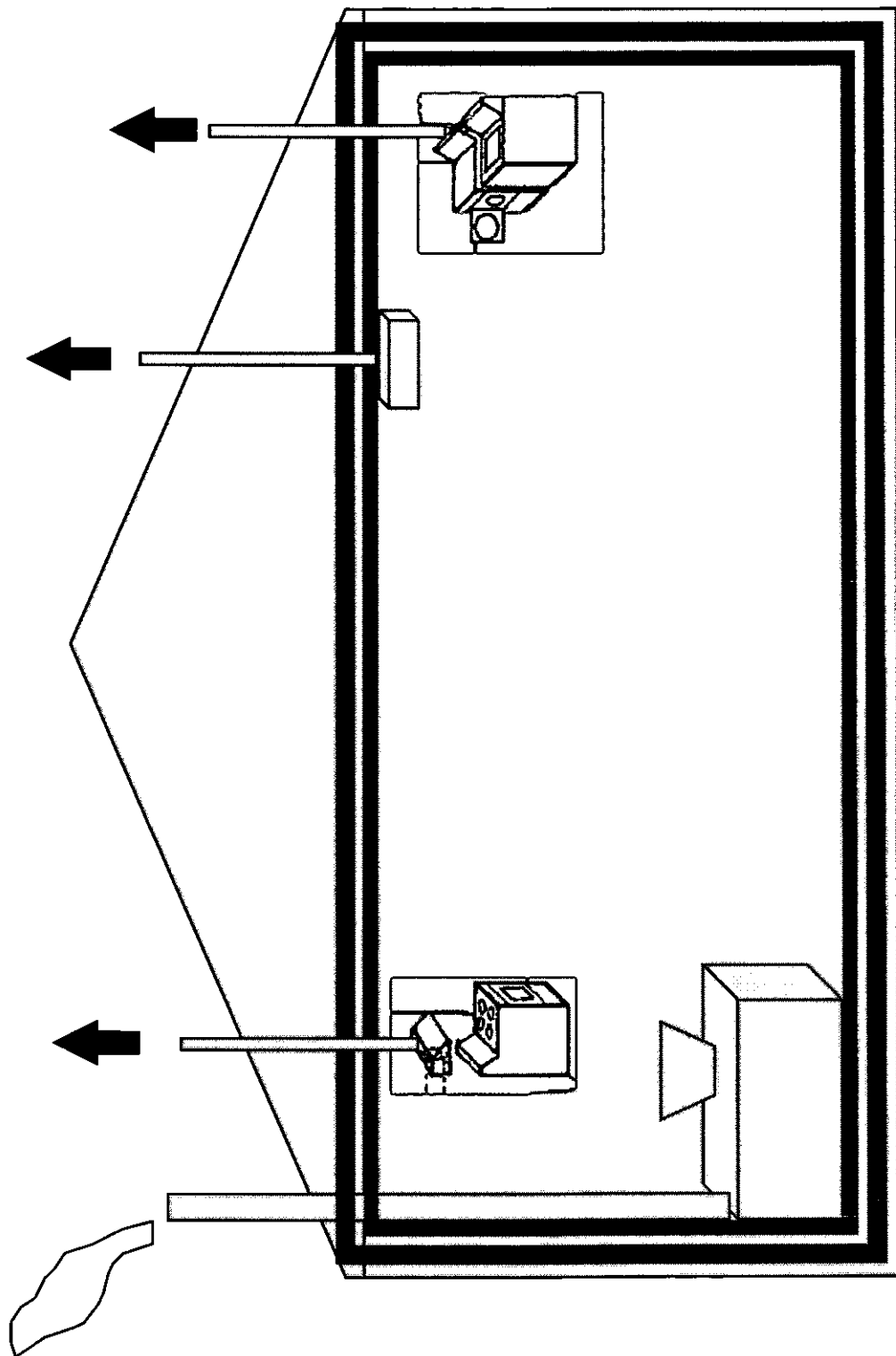

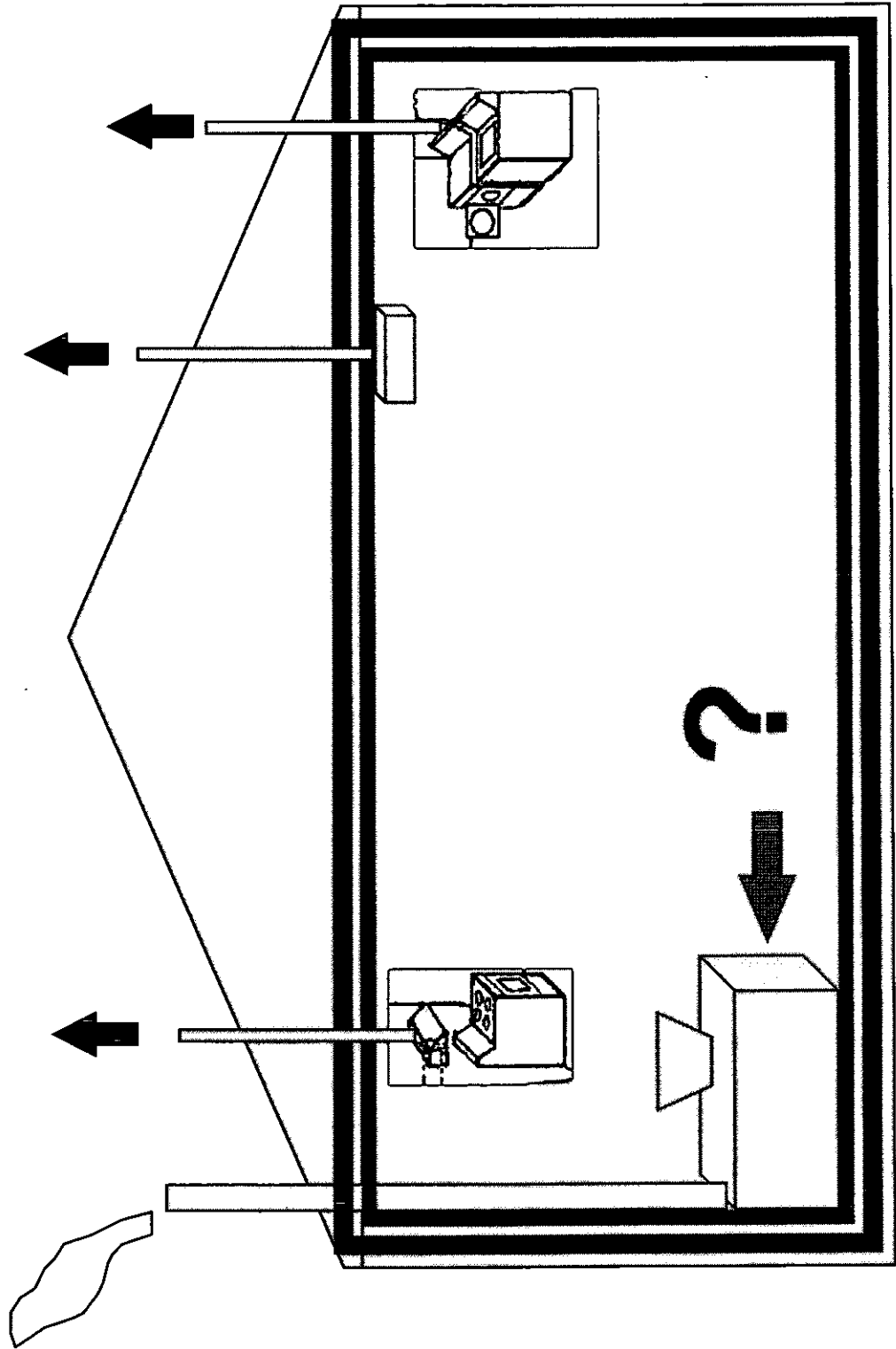

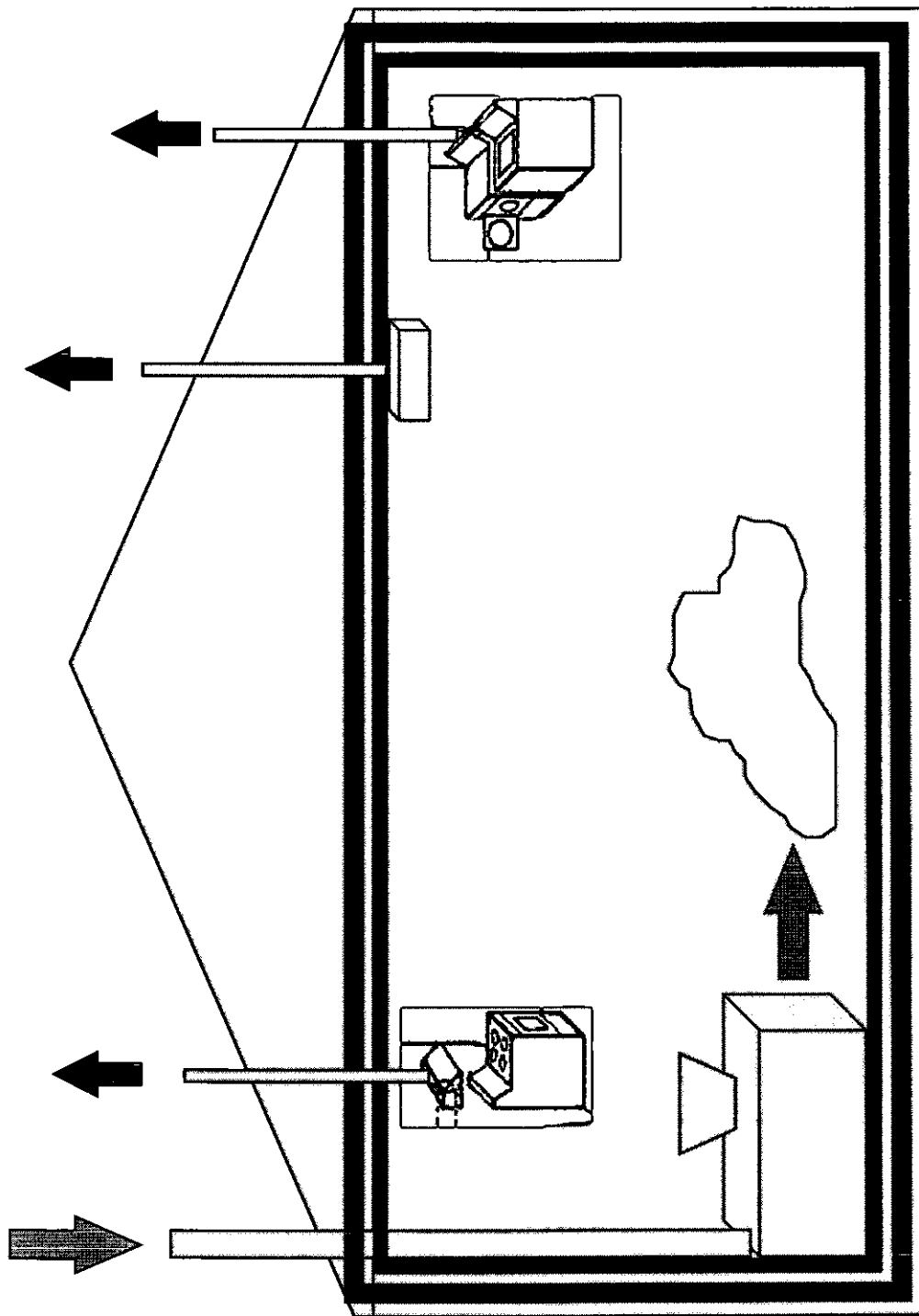

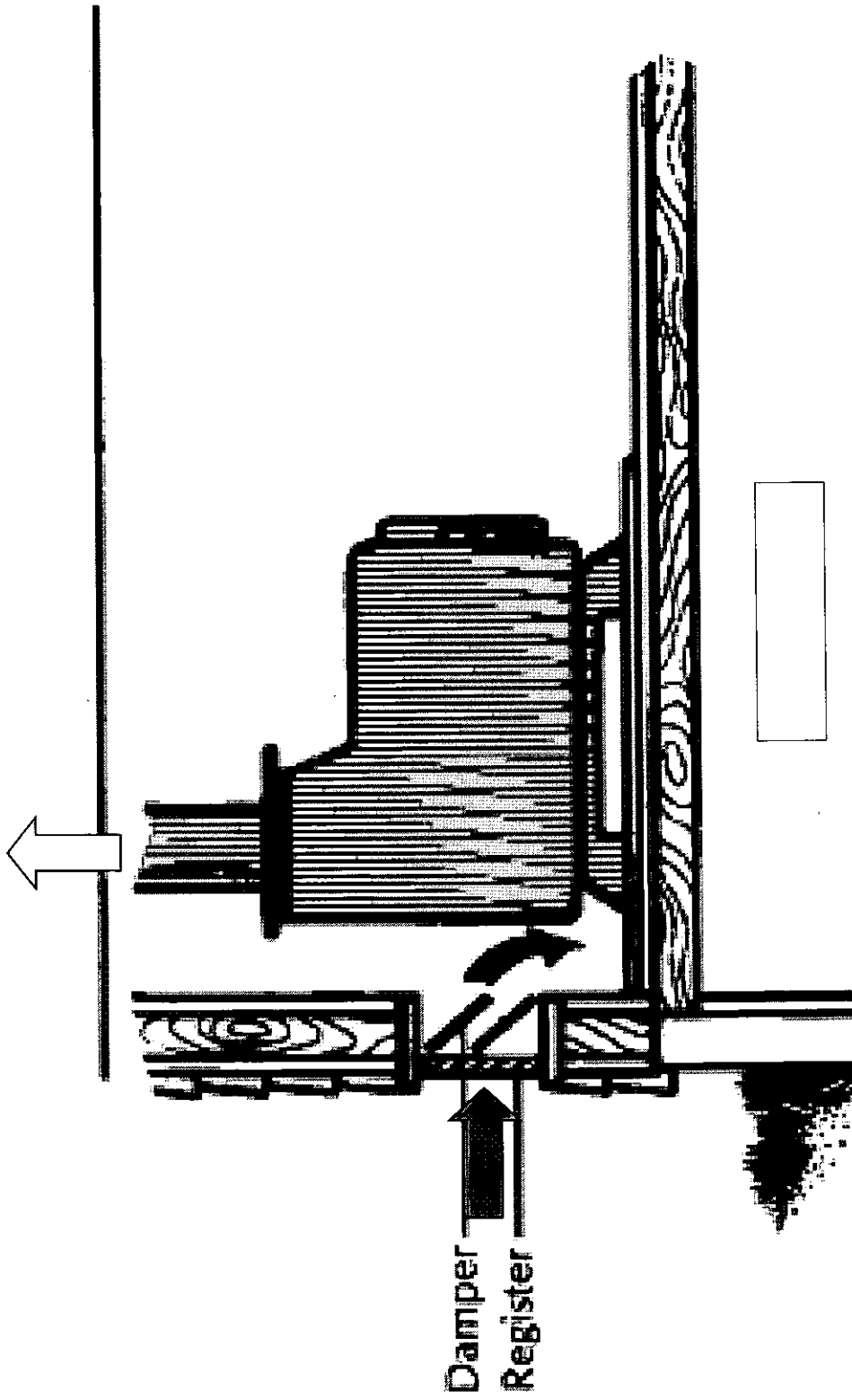

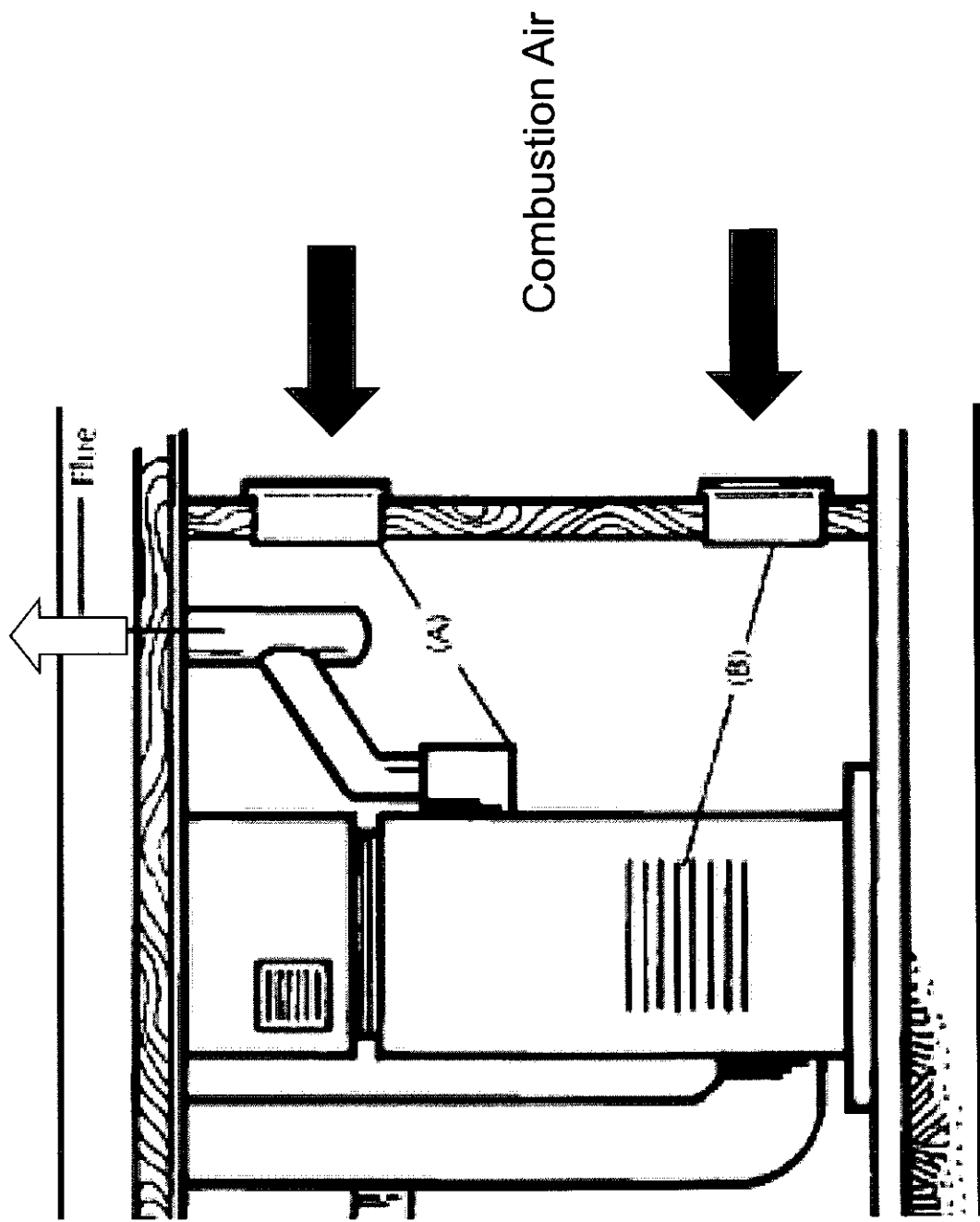

Direct Vent or Sealed Combustion Heating & Hot Water Heaters

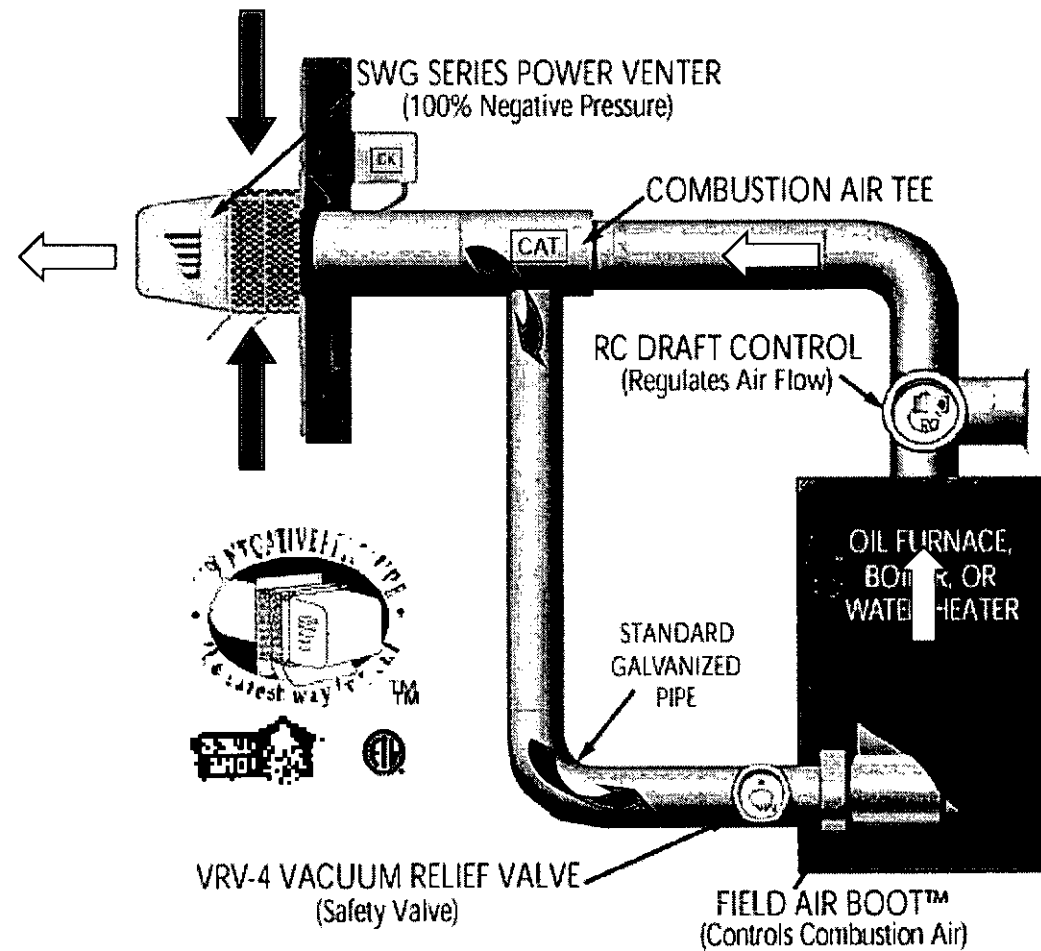

Sealed Combustion Direct Vent Furnace

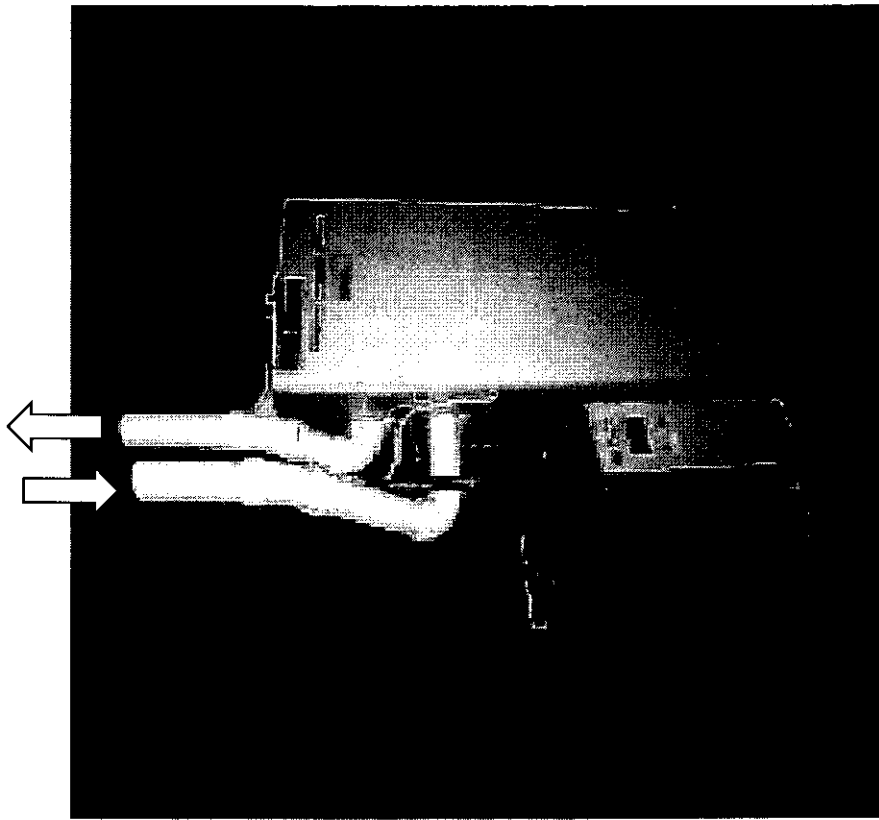

Helps prevent backdrafting

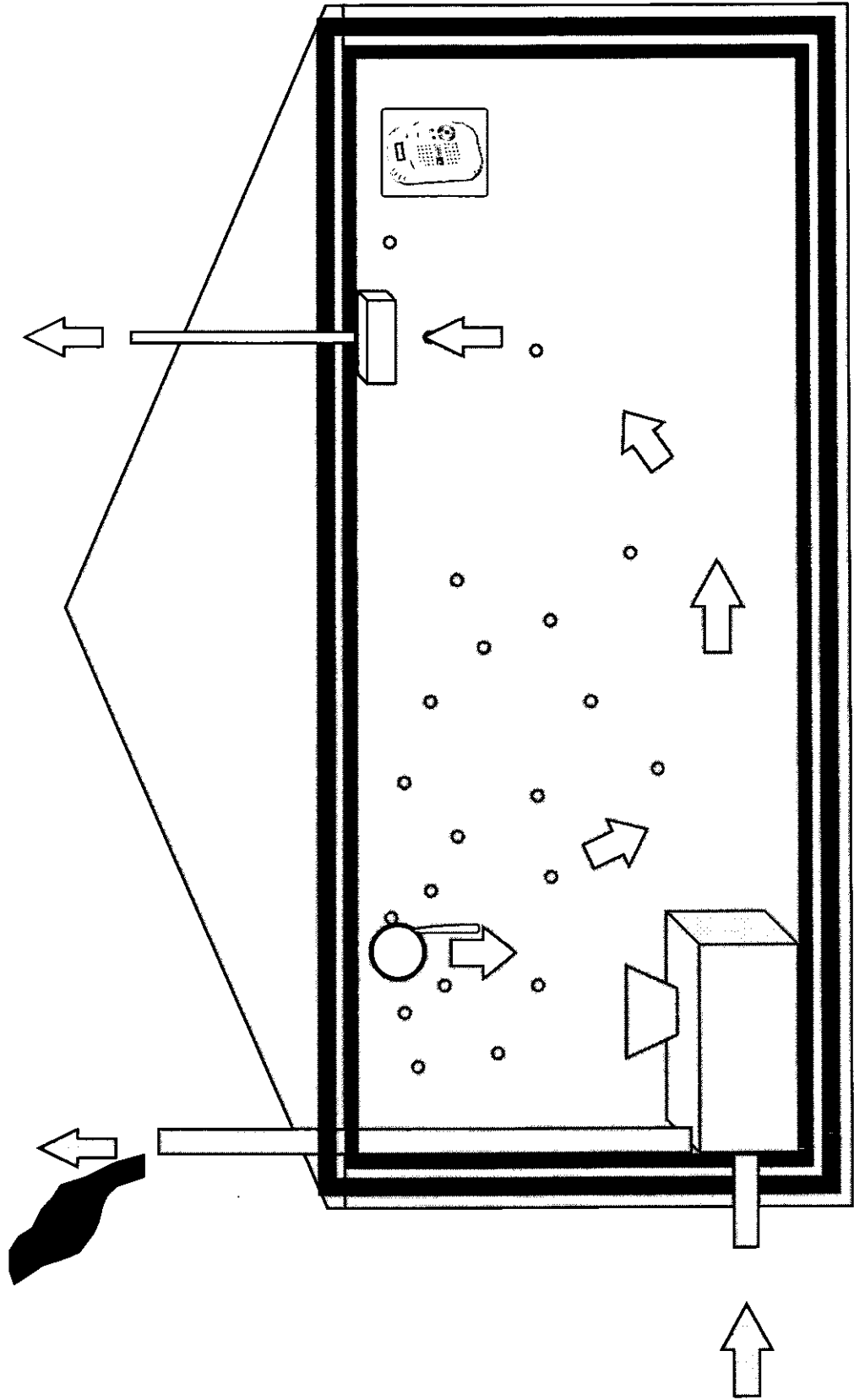

“I only thought about energy.”

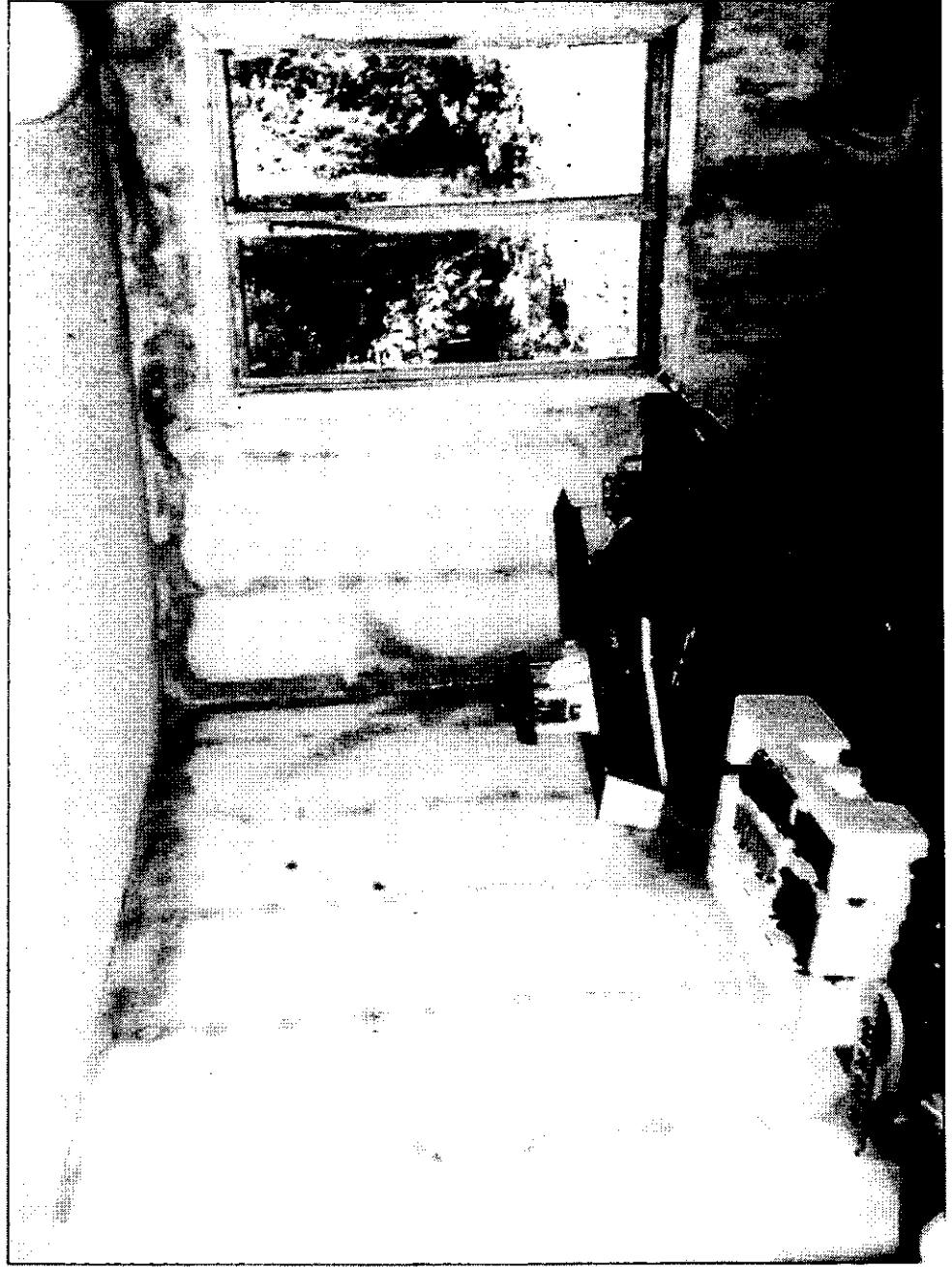

The House is a System
"Build tight... ventilate right!"

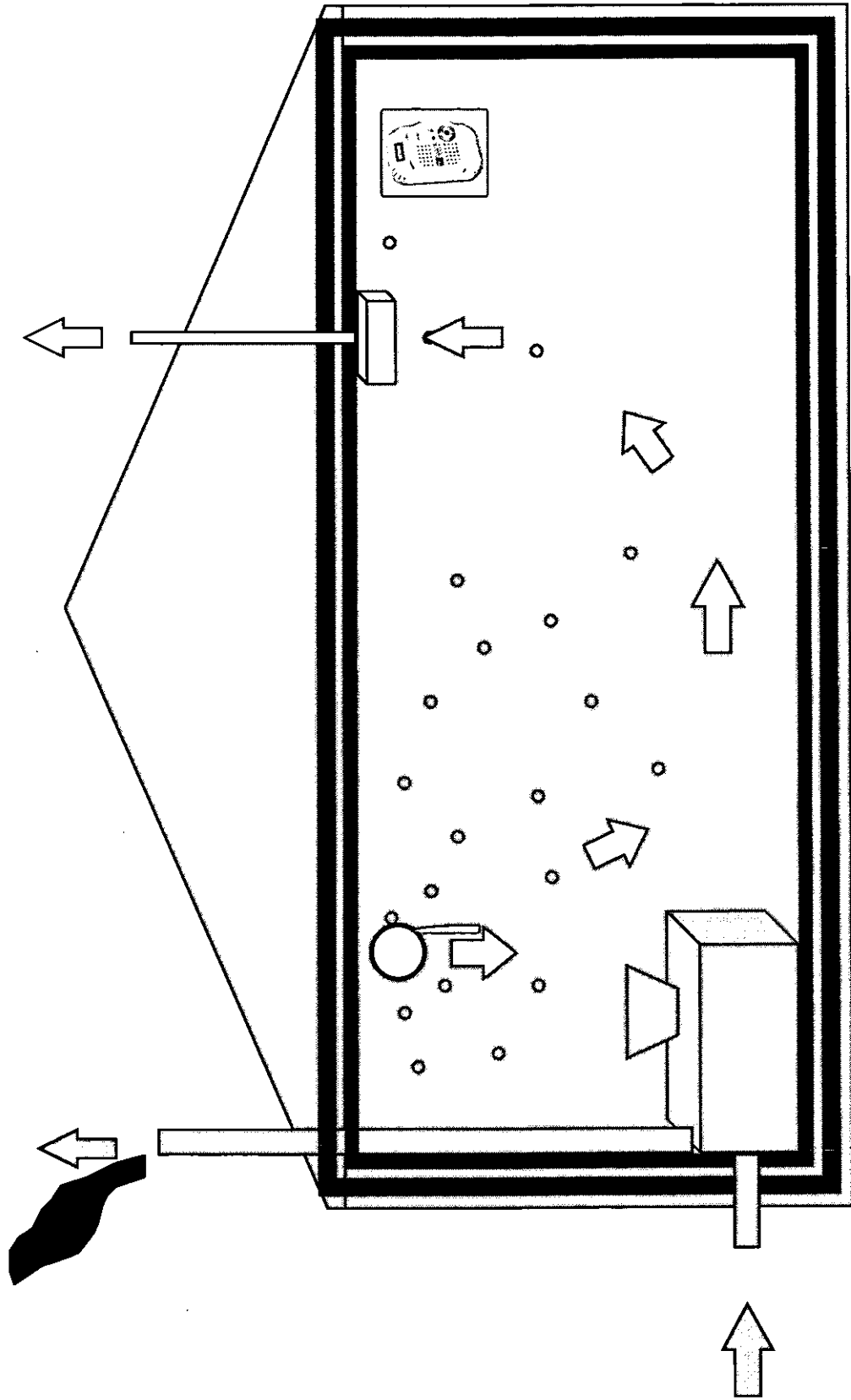

Seal high...

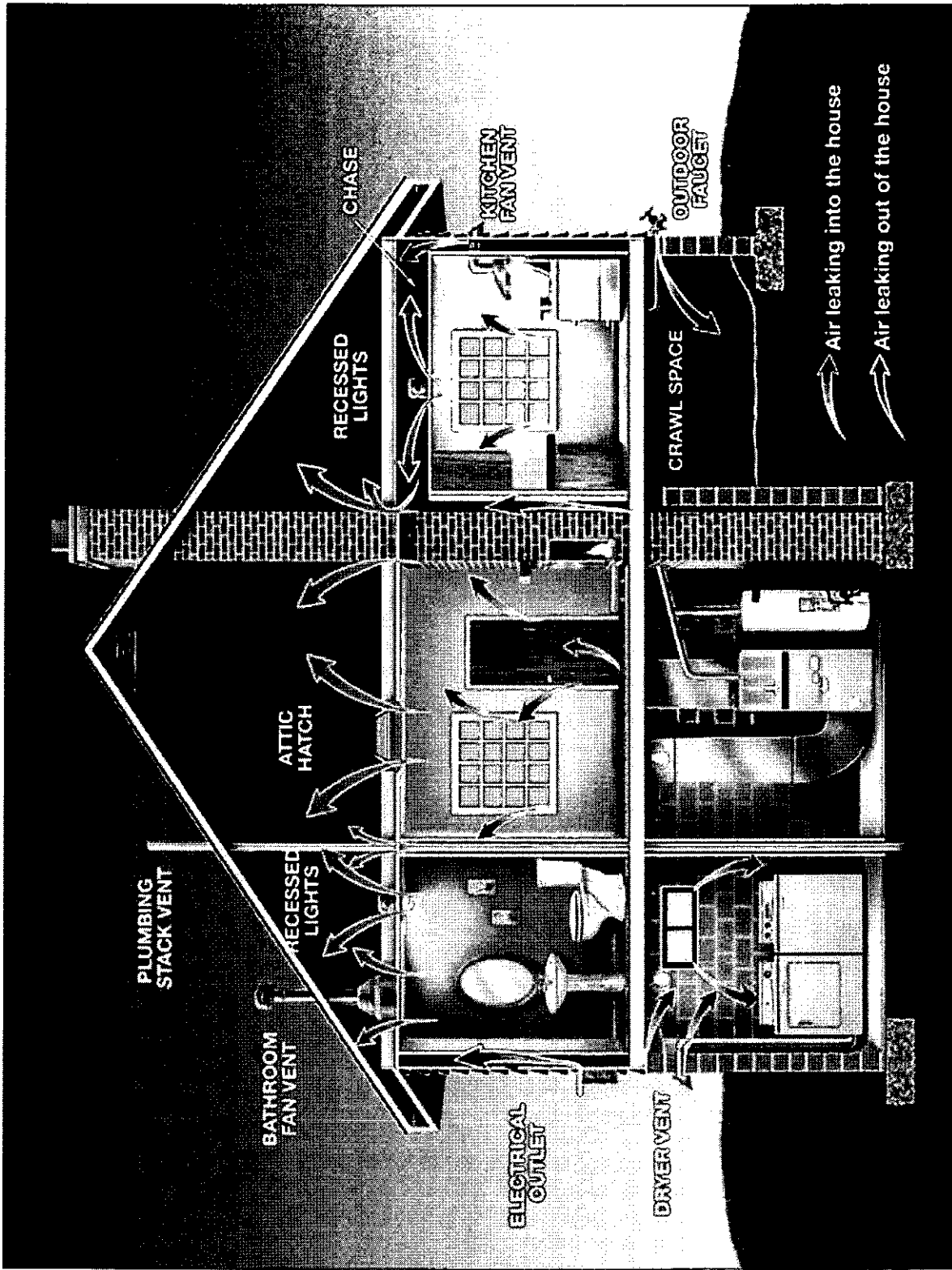

...and seal low

8. FIND ATTIC BYPASSES



The attic bypass...

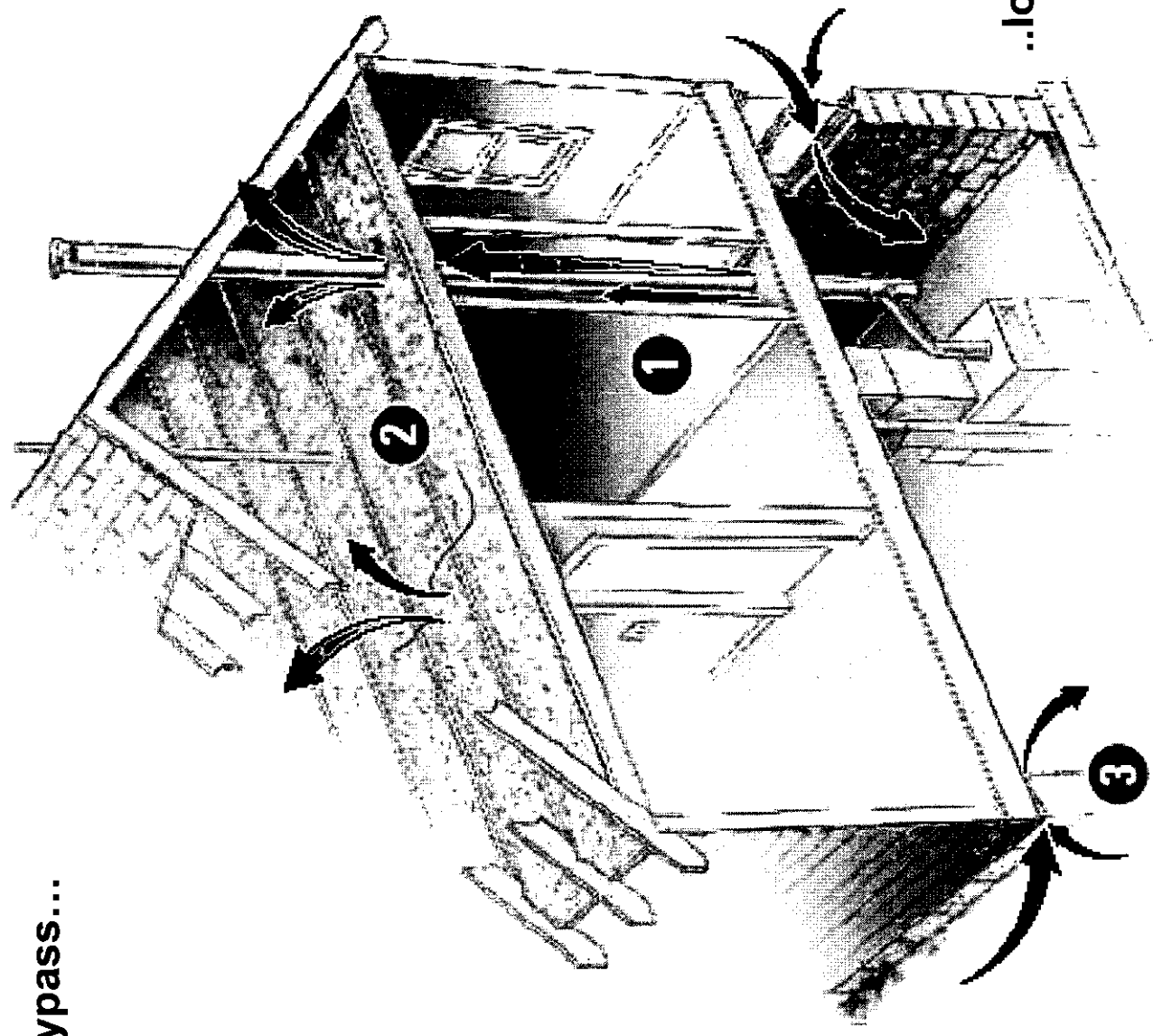

..low leaks exit high

9. FILL HOLES WITH CAULK

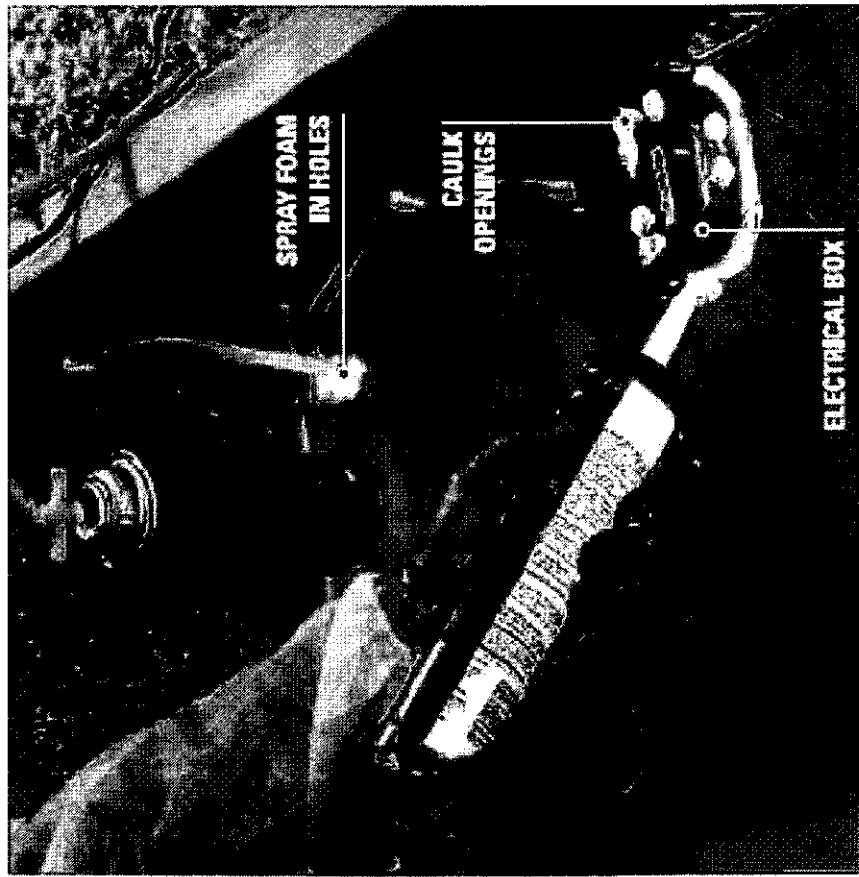

10. STUFF GAPS WITH INSULATION

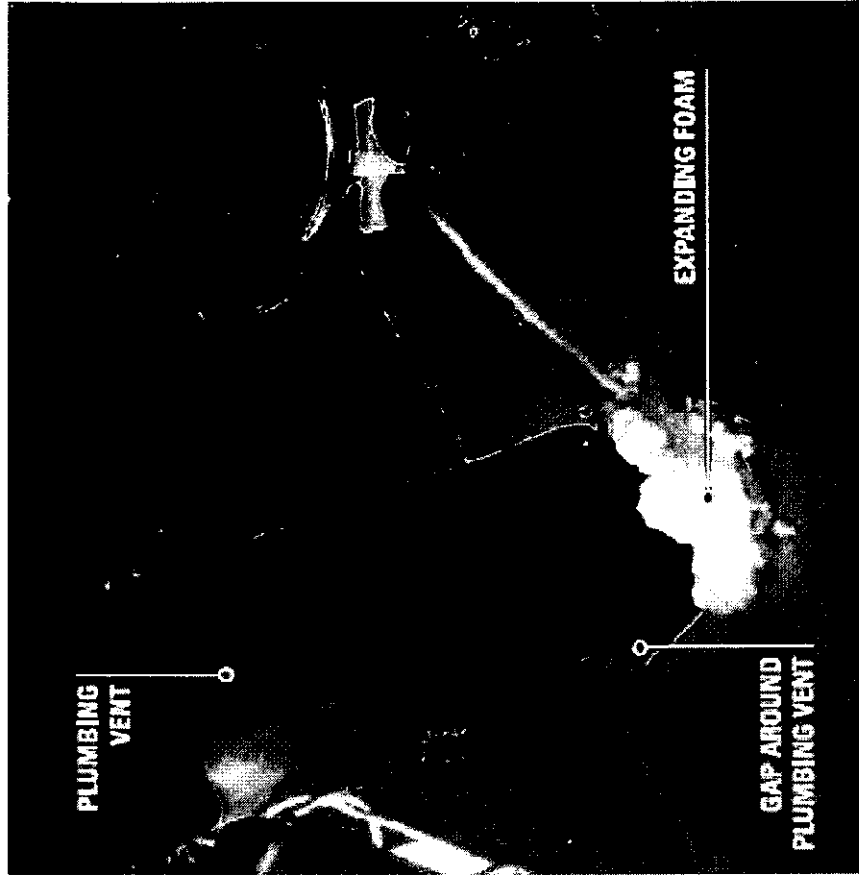

11. WEATHERSTRIP THE DOOR



12. ATTACH FASTENERS

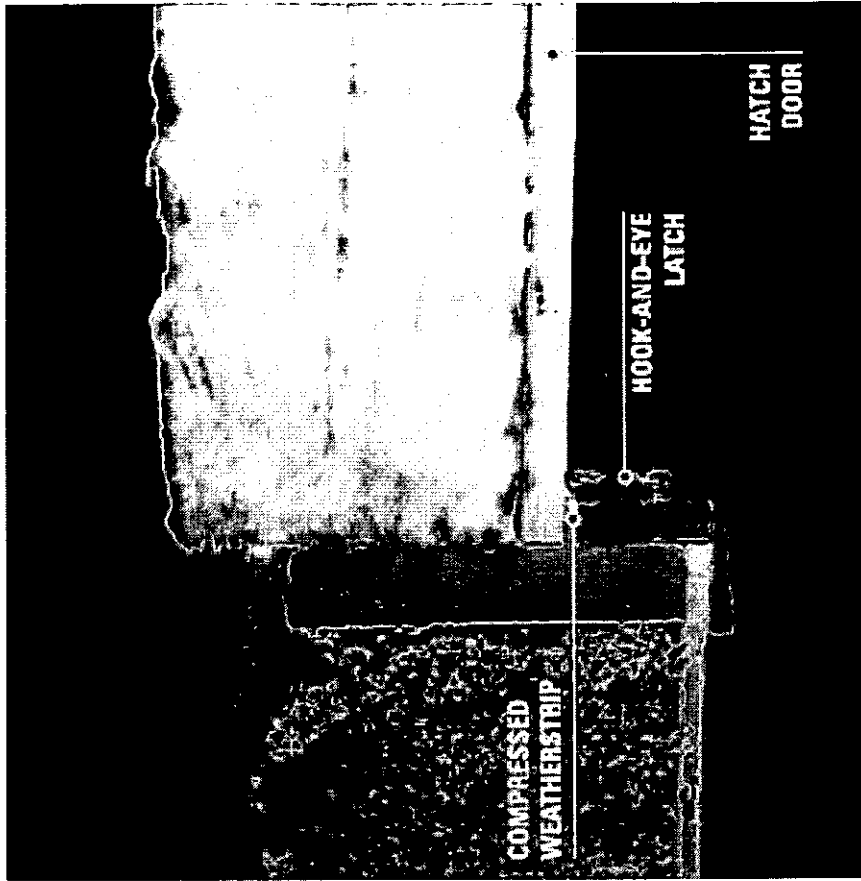

5. CUT ALUMINUM FLASHING

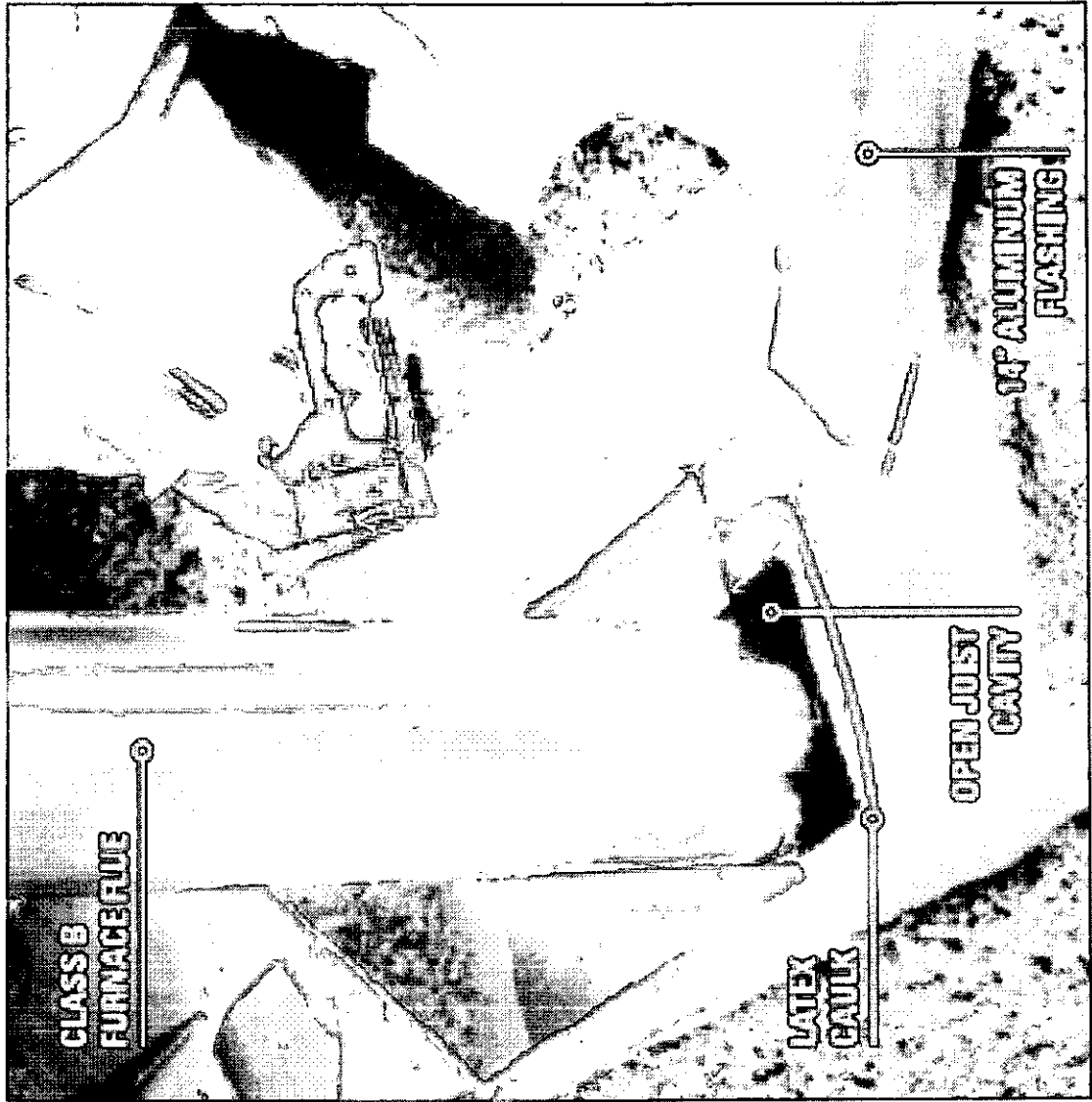

6. SEAL WITH SILICONE CAULK

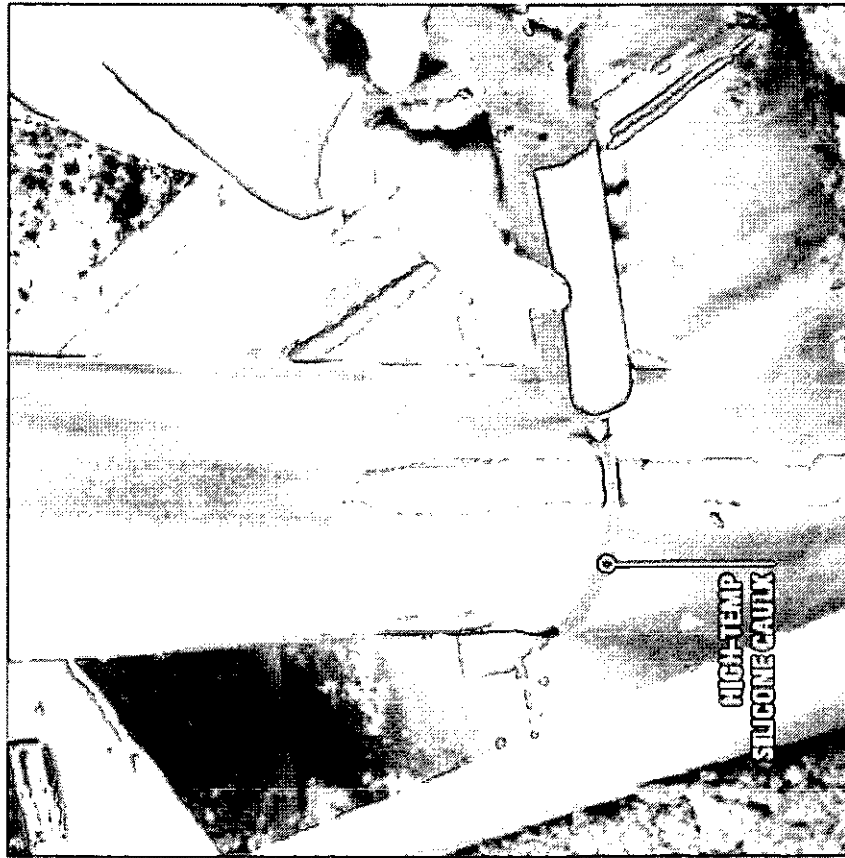

7. FORM AN INSULATION DAM

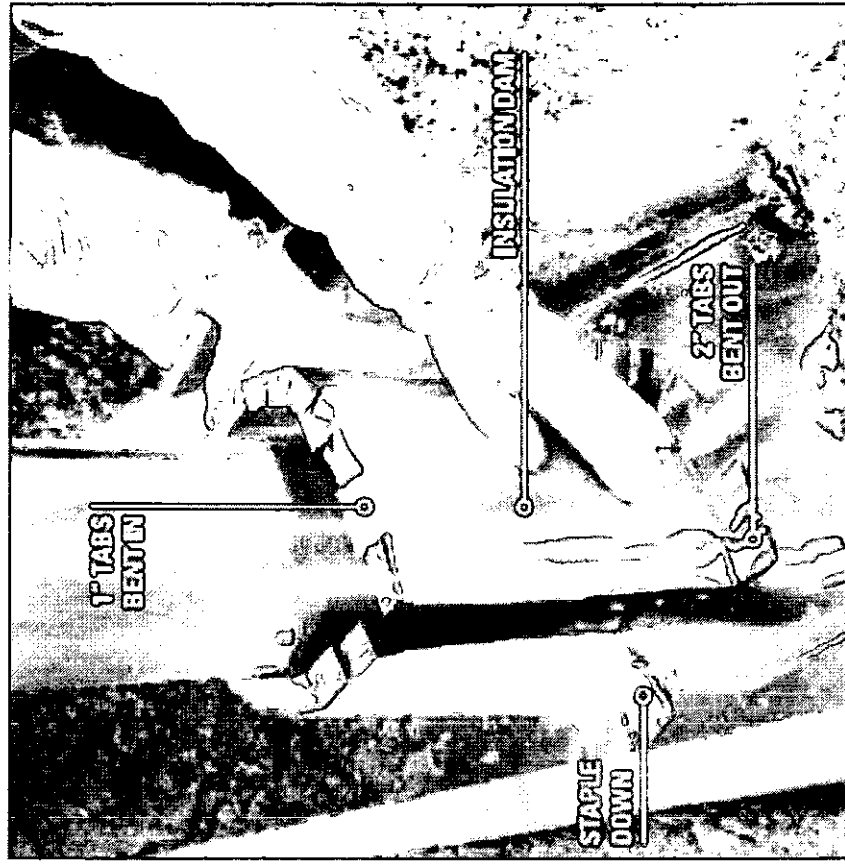

...and seal low

Areas To Foam Or Caulk

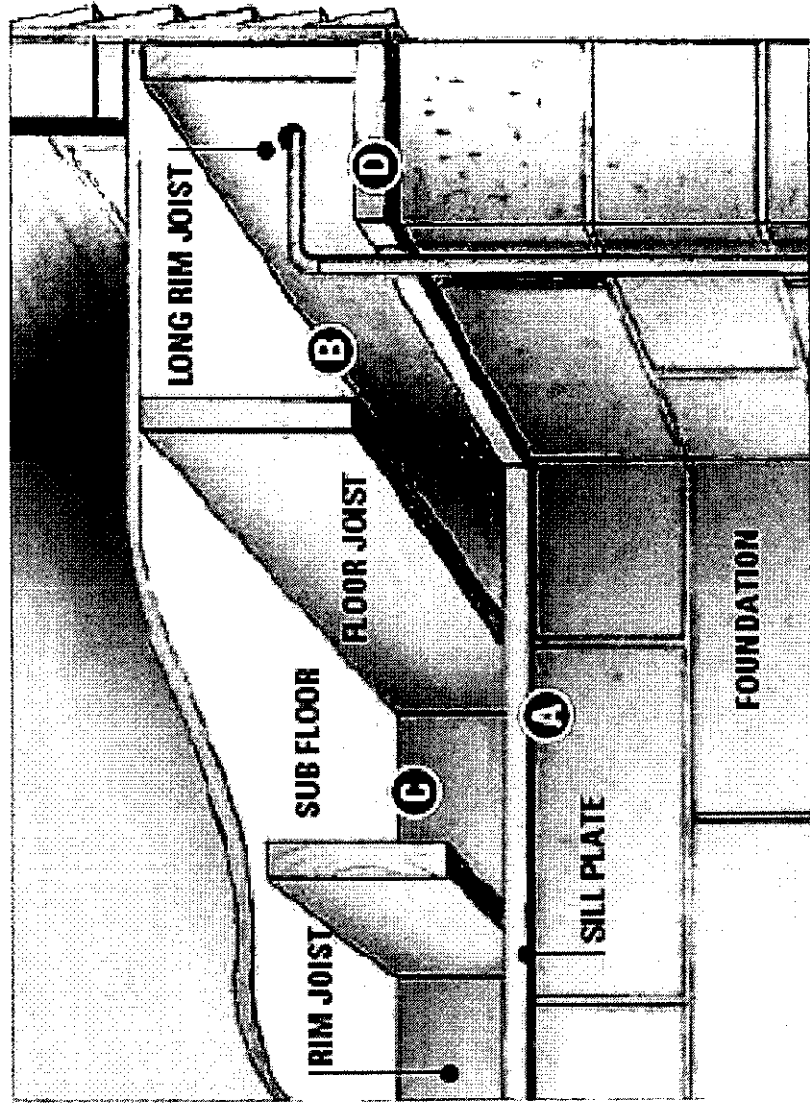
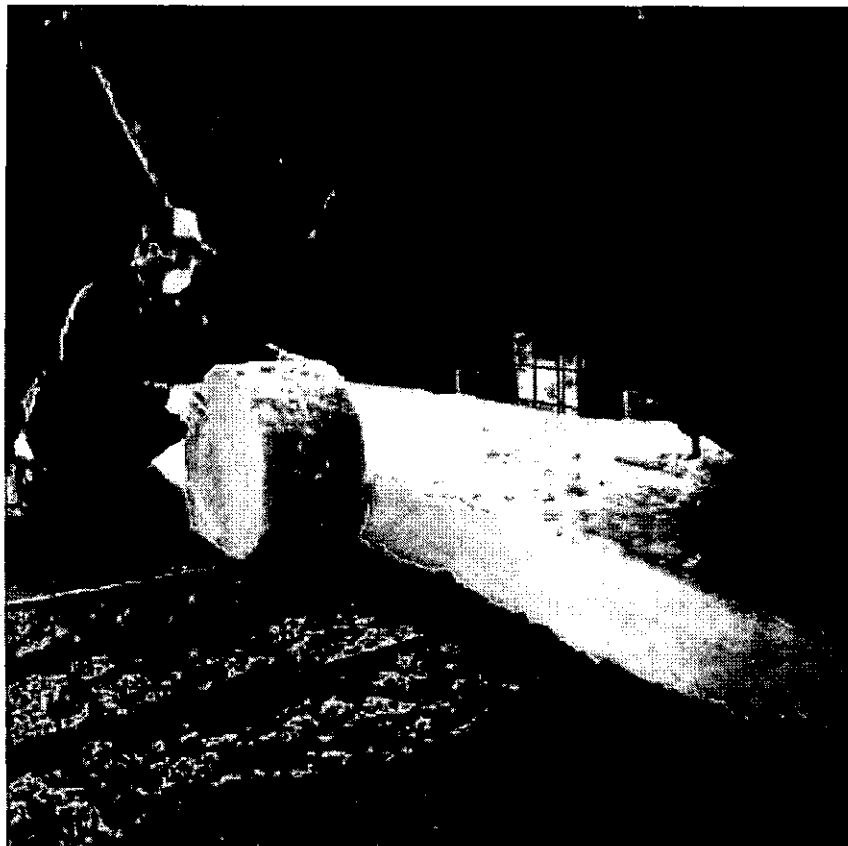

ILLUSTRATION BY DALE HOFFMEYER

Sealed & Insulated Crawlspace



1. LAY FIBERGLASS ROLLS



LAYER FIBERGLASS ROLL INSULATION PERPENDICULAR TO THE JOISTS.

2. CREATE A BARRIER

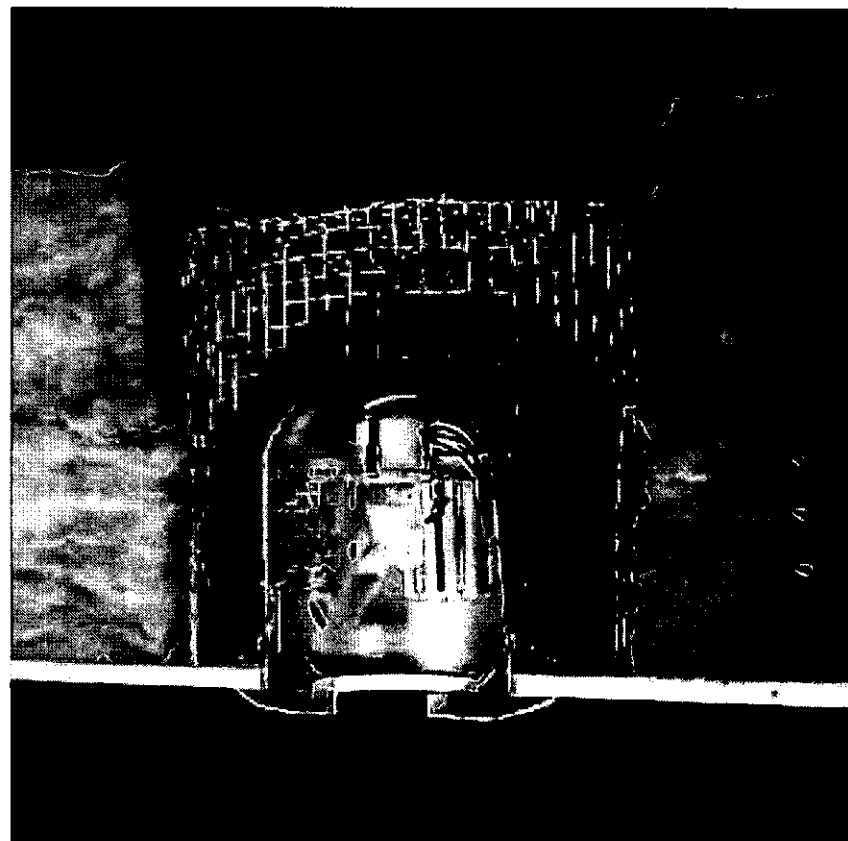

USE SHEET METAL OR WIRE MESH TO HELP CREATE A BARRIER AROUND FIXTURES OR VENTS.

Remember: Insulate AFTER sealing & weatherstripping!



**USE A BLOWING MACHINE TO BLOW
IN LOOSE FILL INSULATION.**

Attic/Roof Ventilation

ILLUSTRATION © FAMILY HANDYMAN MAGAZINE

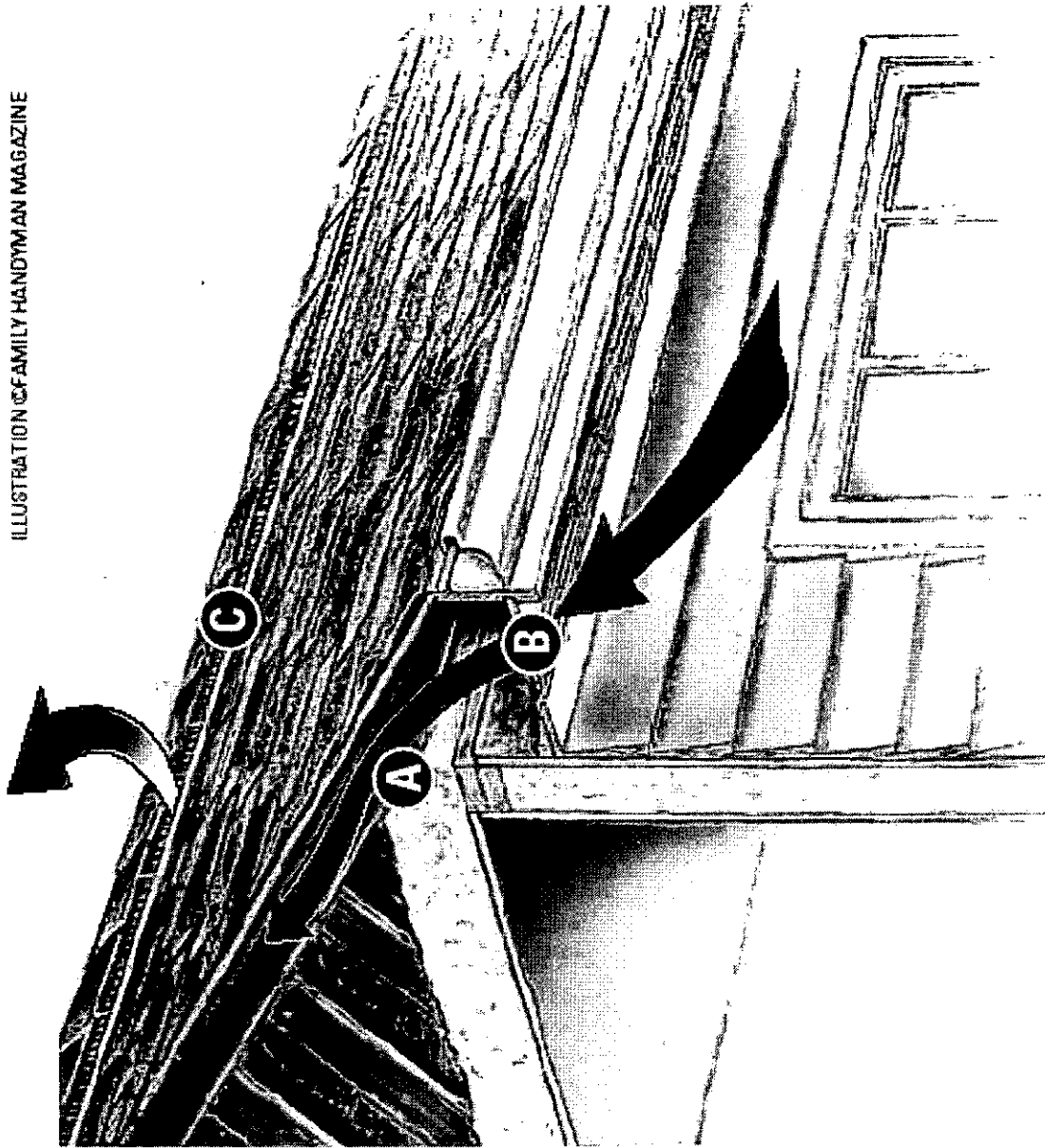

Attic/Roof Ventilation

3. PLACE RAFTER VENTS



PLACE RAFTER VENTS IN-BETWEEN THE RAFTERS WHERE THE CEILING MEETS THE FLOOR.

4. ADD INSULATION

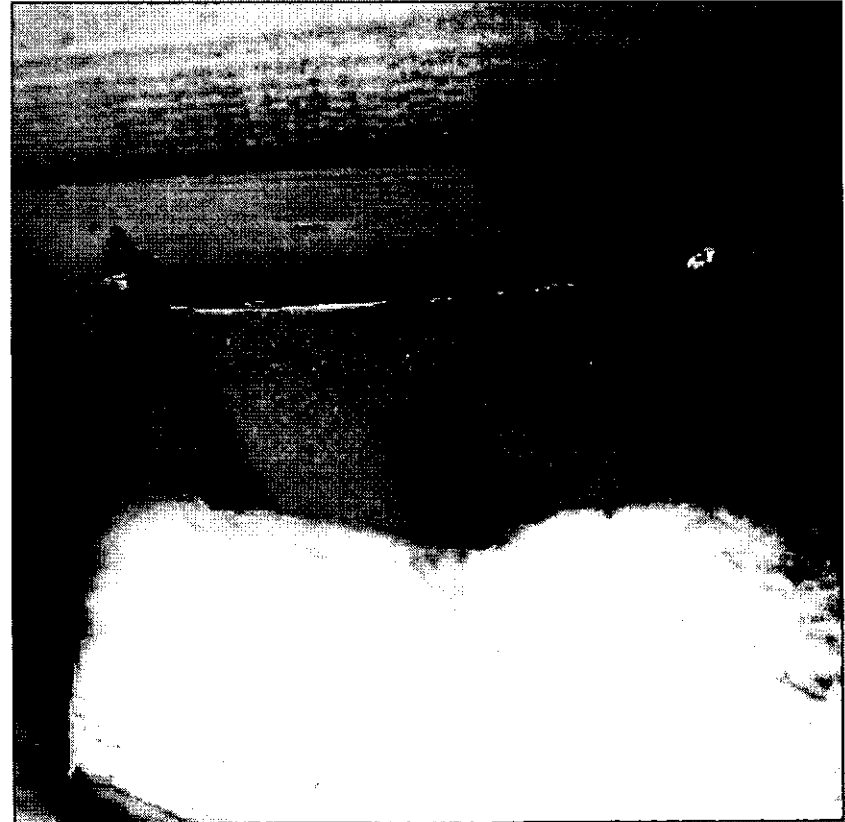

ADD INSULATION AROUND THE RAFTER VENT AND OUT TO THE EDGE OF THE ATTIC FLOOR.

Typical Top Priority Items

- Caulk & seal air leaks high (between the ceiling and attic) and low (around the crawlspace or basement rim joist). Also seal around doors & windows.
- Add additional insulation to the attic, and crawlspace or basement walls.
- Get a heating & water heating system check up.

AND for health & safety:

- Install a quiet, energy efficient bathroom fan
- Make sure you have smoke & CO alarms
- Make sure you've met codes & standards



Alaska
Housing
FINANCE CORPORATION

www.ahfc.us/energy

1-800-478-2432 or 1-907-338-6100