

**PRUDHOE  
BAY  
CORROSION  
CRISIS,  
8/18/06  
(FILE 4)**

**BP & ConocoPhillips  
Commitment to Corrosion Monitoring  
Meet and Confer Presentations  
2001 – 2006**

**Charter for Development of the Alaskan North Slope  
Section II.A.6**

SPRING 2001

*Commitment to Corrosion Monitoring  
April 30<sup>th</sup>  
9:00 am to 2:00 pm  
Semi Annual Review (Meet and Confer)  
Meeting 1*

*Agenda*

*Opening Remarks – (9 to 9:30 am)*

*BP Presentation (9:30 to 10:30 am)*

*Break*

*Phillips Presentation (10:45 to 11:45 am)*

*Lunch Provided (12 to 1:00 pm)*

*Open discussion, questions, and feedback (1 to 2:00 pm)*

BP

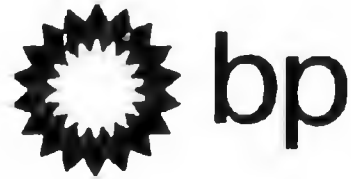

## Commitment to Corrosion Monitoring

BP, Phillips & ADEC Meet and Confer

Session 1, April 2001

*Presented by the*

*Corrosion Inspection & Chemicals Team*

*BPX Alaska*

### Commitment to Corrosion Monitoring



■ **Public perception – corrosion is severe and worsening**

□ **Anchorage Daily News**

- "Corrosion and abrasion are symptoms of aging oil fields, like Prudhoe, which started up 24 years ago".
- "Over the past 15 years, corrosion and abrasion in the Slope's 2,000 miles of oil, water and natural gas pipelines have worsened from occasional problems to constant headaches".

■ **BP perception – corrosion is manageable and we are improving**

□ **BP report to ADEC**

- We believe that the corrosion management programs we set to deliver long term integrity of the existing infrastructure on the North Slope, enabling BPX(A) to achieve its goals of expanding satellite production and the bridge to gas sales.
- Corrosion management and environmental protection are closely related and the progress made in corrosion management has resulted in lower corrosion rates and consequently lower risks associated with loss of containment of pipelines.

■ **Our intent is to work towards a healthy relationship with our stakeholders through open and forthright consultation and reporting**

## Commitment to Corrosion Monitoring



- **Scope of non common carrier North Slope pipelines**
  - 1,000 miles of cross country pipelines
  - 300 miles of well pad pipelines
    - 50% longer than TAPS
    - 2,400 individual lines
  - 1/3 of a million weld packs
  - 1,800 cased pipe segments in 350 road / animal crossings
  - Original construction 25 years old
  - Major gas expansion pipelines 10 - 20 years old
  
- **High level aim of the corrosion management program**
  - Maintain integrity of the existing infrastructure
    - "No harm, no accidents, no damage to the environment"
    - Throughout existing field life — *50 years?*
    - Future satellite development *more*
    - Future gas production

April 30th 2001

BP ADEC Meet and Confer Session 1

3

## Commitment to Corrosion Monitoring



- **Relevant Metal Loss Mechanisms** *-12%*
  - Internal Corrosion – predominantly CO<sub>2</sub> corrosion
    - Causes widespread damage from wellhead to facility
    - Control methods well understood
    - The major threat to the pipeline infrastructure
  - Erosion – mechanical removal by solids
    - Restricted to upstream equipment - wellhead to manifold
    - Often associated with bringing wells on to production
    - Solids production difficult to monitor or predict
  - External Corrosion – oxygen corrosion in wet insulation
    - Causes highly localized damage, mainly at weld packs
    - Greatest exposure to leaks and reputation
    - Cause of:
      - Both of GPB's corrosion-related pipeline leaks in 2000

April 30th 2001

BP ADEC Meet and Confer Session 1

4

## Commitment to Corrosion Monitoring

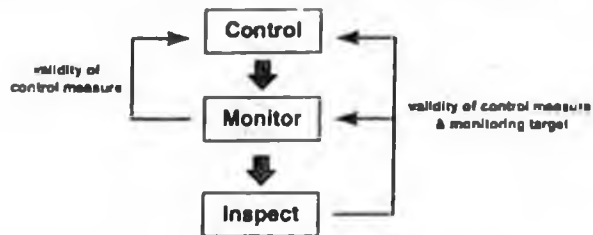

### **Structure of the Corrosion Management Programs**

- **Control**
  - Prevention or reduction of corrosion *to acceptable levels*
- **Monitor**
  - The measurement of success of the corrosion control activity
- **Inspect**
  - The final verification of the success of control activities
  - Determination of equipment's fitness for service
- Integration of all 3 elements is required to manage integrity

April 30th 2001

BP ADEC Meet and Confer Session 1

5

## Commitment to Corrosion Monitoring



### ■ **Internal corrosion & erosion control**

- **Chemical inhibition**
- **Process**
  - Flow velocity control
  - Well start up procedures
- **Materials selection**
- **Engineering design**
- **Coatings**
- **Cathodic protection**
- **Repair / replacement**

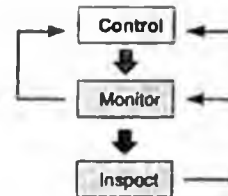

### ■ **Typical target values**

- Corrosion inhibitor concentration e.g. 150 ppm
- Flow velocity, based on diameter & water cut
- Erosional velocity  $V/V_e < 2.0$

April 30th 2001

BP ADEC Meet and Confer Session 1

6

## Commitment to Corrosion Monitoring



### GPB CO<sub>2</sub> Internal corrosion control

- Inhibition rates determined by monitoring & inspection data
  - Amount of inhibitor used is increasing
  - Amount of water handled is approximately constant
  - Concentration of inhibitor is increasing
- The purpose is to reduce corrosion rates

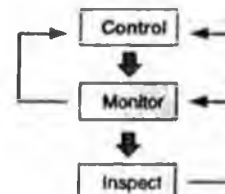

Table 7: Water production, corrosion inhibitor usage and concentration

Year	Water production (million barrels)	Inhibitor Usage (million gallons)	Concentration (ppm)
1996	458.4	2.05	108
1997	456.3	2.21	115
1998	426.0	2.53	141
1999	415.7	2.28	130
2000	436.3	2.73	149

April 30th 2001

BP ADEC Meet and Confer Session 1

7

## Commitment to Corrosion Monitoring



- Internal corrosion monitoring
  - Electrical resistance (ER) probes
  - Weight loss coupons
- Typical target values
  - ER probes 0.5 – 10 mpy
  - Coupons < 2 mpy general corrosion

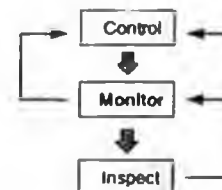

Table 4: Number of Corrosion Monitoring Coupons

Year	Cross country	Well Lines	PW	SW	GL & Inj	Total
1996	1,324	6,195	1,125	750	4	9,536
1996	1,469	7,676	1,140	744	10	11,193
1997	1,467	7,784	1,207	868	10	11,574
1998	1,490	7,562	1,138	732	10	11,094
1999	1,425	6,875	1,010	782	10	10,238
2000	1,371	5,855	816	782	10	8,970

Table 5: Corrosion Monitoring Probes

Location	No. of Probes
Well lines	78
Cross Country pipelines	84

April 30th 2001

BP ADEC Meet and Confer Session 1

4

## Commitment to Corrosion Monitoring



### GPB Internal corrosion monitoring data

- % of coupons meeting target is increasing
- Corrosion rates are reducing
- Reflects increase in corrosion inhibitor usage

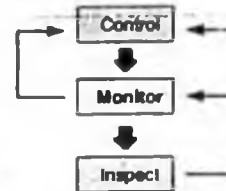
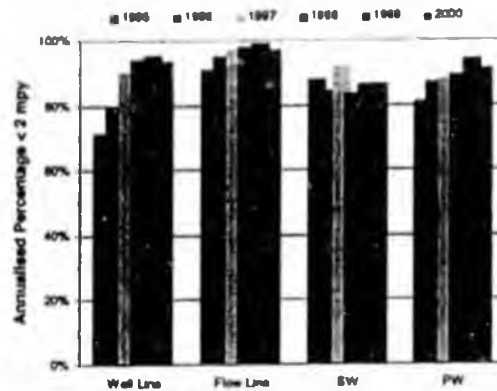

April 30th 2001

BP ADEC Meet and Confer Session 1

## Commitment to Corrosion Monitoring



### Internal Inspection

- Metal loss rate
  - Corrosion Rate Monitoring - CRM
  - Erosion Rate Monitoring - ERM
- Mechanical Integrity
  - Frequent Inspection Program - FIP
  - Comprehensive Integrity program - CIP
  - Smart pigging

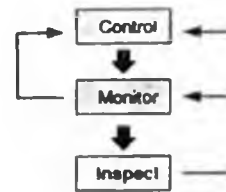

### Typical target values

- Control
  - Zero detectable corrosion
- Mechanical Integrity
  - Modified B31.G
  - 0.100" minimum wall
  - 100% MAOP
- Repairs scheduled at 105% of fitness for service criteria

April 30th 2001

BP ADEC Meet and Confer Session 1

10

## Commitment to Corrosion Monitoring



### GPB Internal Inspection data

- Pipewall corrosion rates are reducing
- o Reflects increase in corrosion inhibitor usage
- o Confirms trends seen in monitoring data

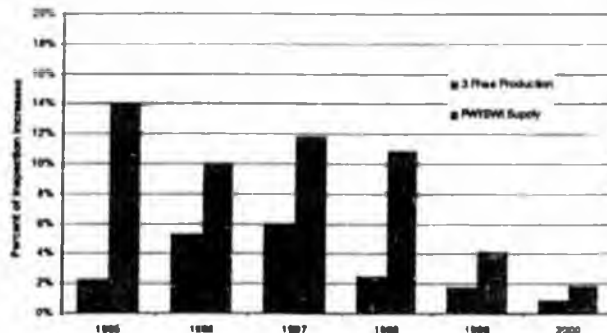
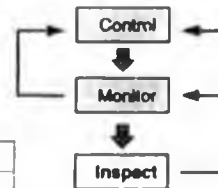

April 30th 2001

BP ADEC Meet and Confer Session 1

11

## Commitment to Corrosion Monitoring



### Hollistic view of integrity management

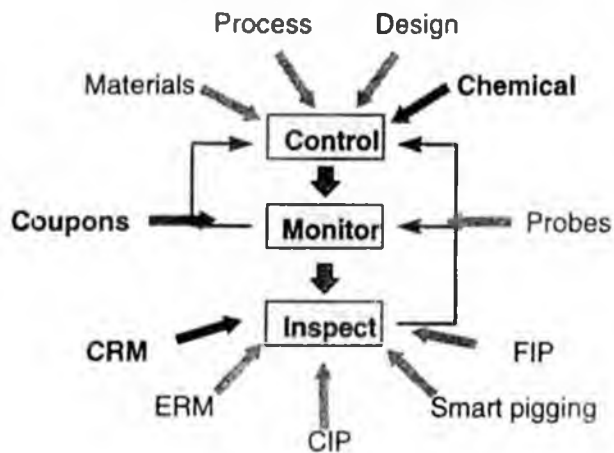

April 30th 2001

BP ADEC Meet and Confer Session 1

12

## Commitment to Corrosion Monitoring



### *End result of internal corrosion management programs*

- Corrosion rates have fallen
- Control, monitoring & inspection show similar trends
- Corrosion rates are the lowest for 12 years

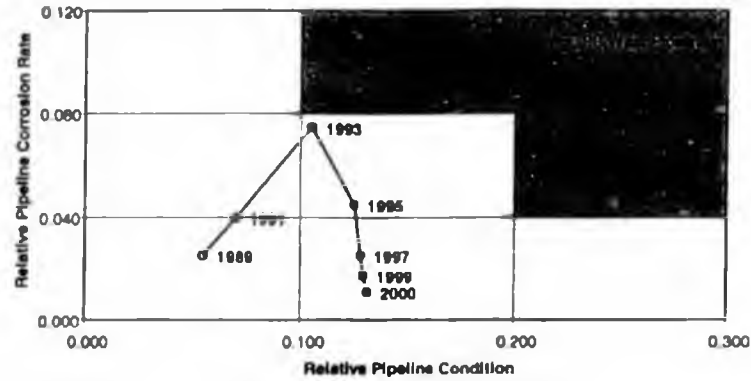
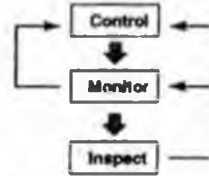

April 30th 2001

BP ADEC Meet and Confer Session 1

13

## Commitment to Corrosion Monitoring



### *Remaining life of pipeline network has increased*

- Life has been increased by reducing corrosion rate
- Not necessary to manage life by replacing pipelines
- Corrosion management and field life are in alignment
- Successfully breaks the repair / replacement cycle associated with ageing oil fields

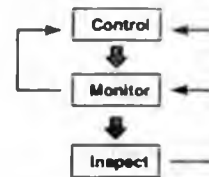

% Pipelines with Life Estimate Greater than Year 2050		
	West Pipelines	East Pipelines
1996 - 1999 Life Model	54%	na
1998 - 2001 Life Model	95%	96%

April 30th 2001

BP ADEC Meet and Confer Session 1

14

## Commitment to Corrosion Monitoring



- **External corrosion**
  - Significant exposure to leaks and reputation
    - Both of GPB's corrosion related pipeline leaks in 2000
  - Highly localized damage, random process
    - Leads to localized repairs, not pipeline replacement
    - Managing 1/3 million weld packs, not 2,400 pieces of equipment
  - ▫ Cased road crossings difficult to inspect & repair

April 30th 2001

BP ADEC Meet and Confer Session 1

15

## Commitment to Corrosion Monitoring



- **External corrosion control**
  - Removal or repair of insulation
  - Localized coating
  - Cathodic protection in cased crossings
  - 'Inhibitor spikes' being developed
- **Typical target values**
  - Remove or repair insulation before pipeline requires a mechanical repair
    - External corrosion control is currently reactive
    - Aim to move to proactive control with inhibitor spikes

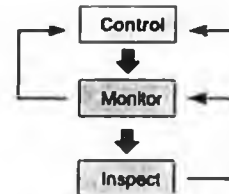

Table 11: Mechanical Repairs Installed

Service	Internal	External
Cross country	1	1
Production well line	6	13
Lift Gas	0	3
PWI	0	6

April 30th 2001

BP ADEC Meet and Confer Session 1

16

## Commitment to Corrosion Monitoring



### External monitoring & inspection

- Tangential radiographic testing - TRT
- Automated TRT
- C-scan
- Eddy current
- Smart pig
- Electromagnetic wave
- Guided wave

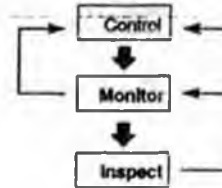

### Typical target values

- Control
  - Irregular surface contour - T<sub>max</sub>
  - 'Significant' or 'severe' anomalies
- Mechanical Integrity
  - Modified B31.G
  - 0.105" minimum wall
  - 105% MAOP

Table 8: Recurring Frequency of CUI Inspection Surveys

Equipment Temperature	Interval Between Examinations (Years)
≤80° F	10
>80 - 120° F	8
>120 - 150° F	6
>150° F	4

April 30th 2001

BP ADEC Meet and Confer Session 1

17

## Commitment to Corrosion Monitoring



### GPB external corrosion control

- Driven by inspection program
- Detection & repair rates falling
- Indicates program is successful at reducing risk

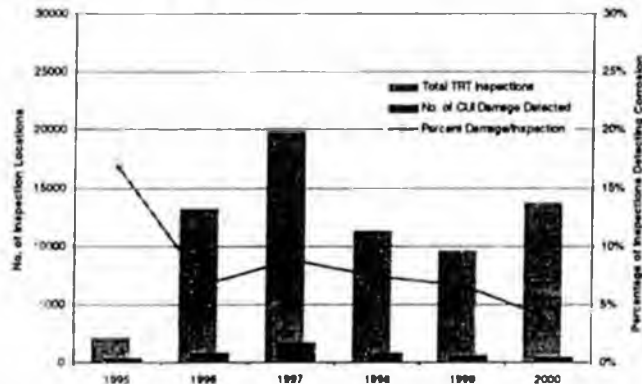
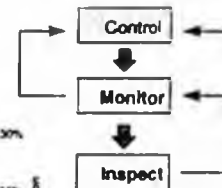

April 30th 2001

BP ADEC Meet and Confer Session 1

18

## Commitment to Corrosion Monitoring



### • Summary

- Internal corrosion
  - Control method is understood and manageable
  - Current rates of corrosion are the lowest for 12 years
  - Remaining pipeline life is being managed via reduction in corrosion rates
  - Strategies for field life and corrosion management are in alignment
- External corrosion
  - Limited options for control and monitoring
  - Current program is reducing risk by eliminating corroded areas
  - New control and inspection technology will play key role in the future
- Overall
  - Corrosion rates are lower than for many years
  - Risk of loss of containment is lower than for many years

April 30th 2001

BP ADEC Meet and Confer Session 1

19

## Commitment to Corrosion Monitoring



### Summary of recent leak & save data

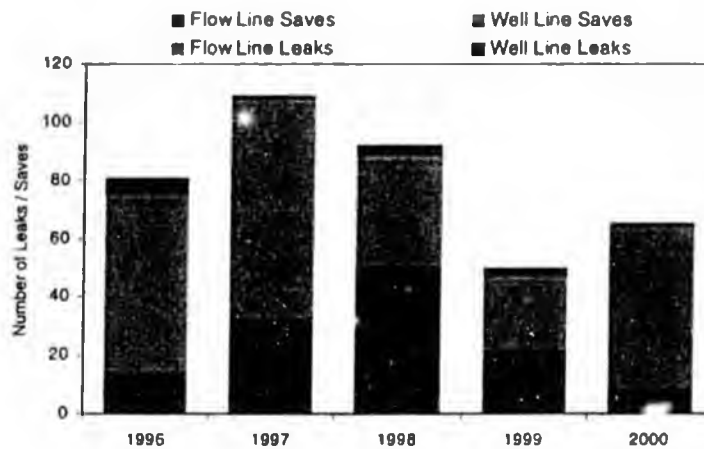

April 30th 2001

BP ADEC Meet and Confer Session 1

20

## Commitment to Corrosion Monitoring



### *Areas of Focus for 2001*

- Program Integration
  - Significant progress made in 2000
  - Substantial work remains to be done
- Control
  - Maintain or improve corrosion control of cross country pipelines
  - Rationalize number of corrosion inhibitors
  - Automated chemical tracking system
    - Improve chemical wellhead distribution
- Monitor
  - Development of enhanced erosion monitoring program
  - Unification of weight loss coupon program
- Inspect
  - Common database
  - Digital radiography
  - Smart pig 3 pipelines
  - 200 cased pipe segments using electromagnetic & guided wave

April 30th 2001

BP ADEC Meet and Confer Session 1

21



## Back Up Slides

22



Greater Prudhoe Bay Figure 1  
Summary of Corrosion Coupon data 1995 - 2000

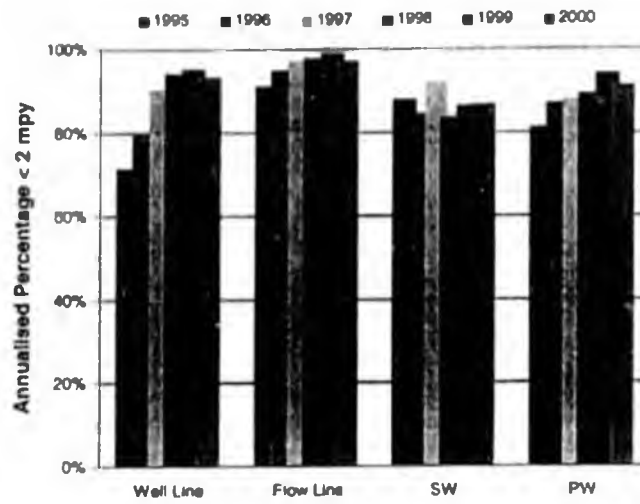

April 30th 2001

BP ADEC Meet and Confer Session 1

23



Greater Prudhoe Bay Figure 2  
Chemical optimization in response to corrosion probe data

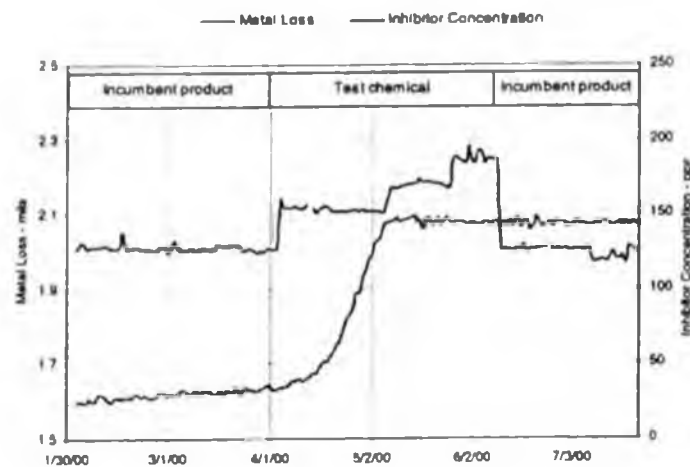

April 30th 2001

BP ADEC Meet and Confer Session 1

24



Greater Prudhoe Bay Figure 3  
External Inspection using tangential radiographic testing

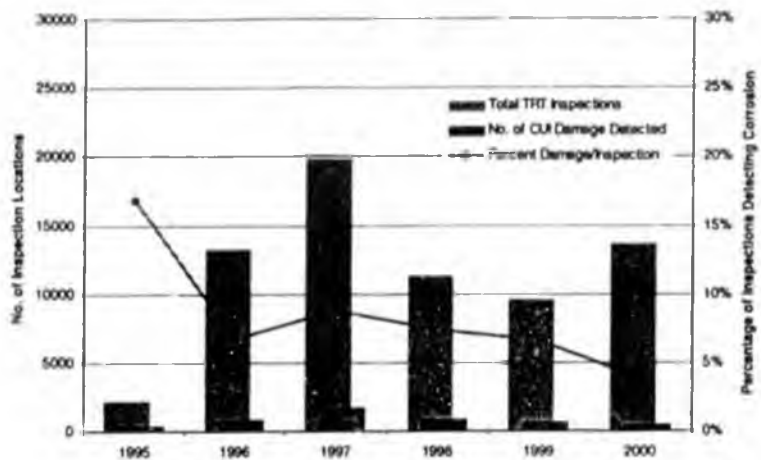

April 30th 2001

BP ADEC Meet and Confer Session 1

25



Greater Prudhoe Bay Figure 4  
Detection of internal corrosion of well lines by inspection

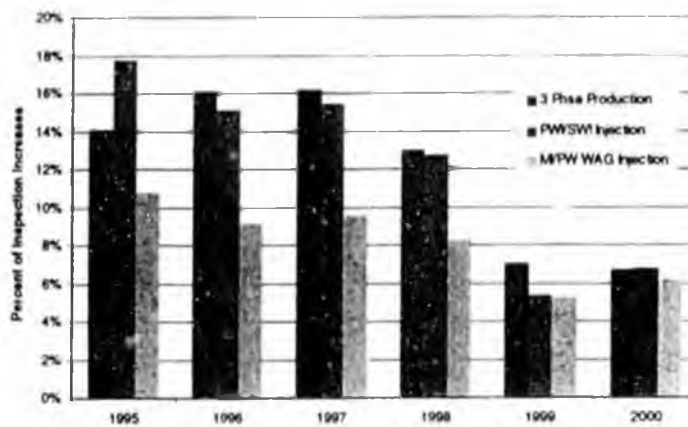

April 30th 2001

BP ADEC Meet and Confer Session 1

26



Greater Prudhoe Bay Figure 5  
Detection of internal corrosion of cross country pipelines

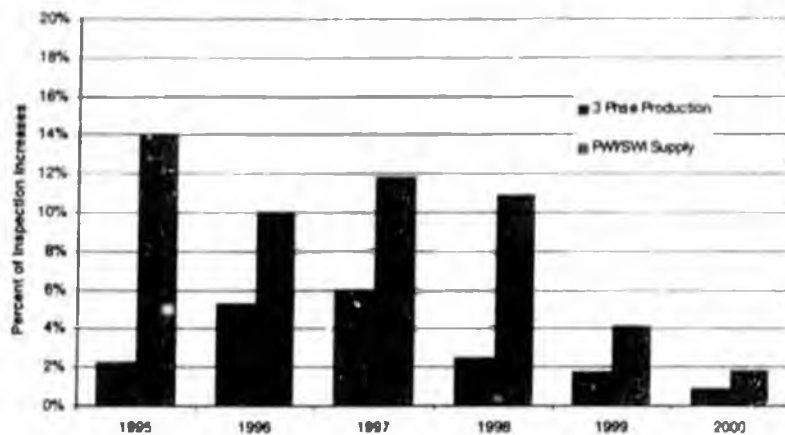

April 30th 2001

BP ADEC Meet and Confer Session 1

27



Greater Prudhoe Bay Figure 6  
Leaks and saves of well lines and cross country lines

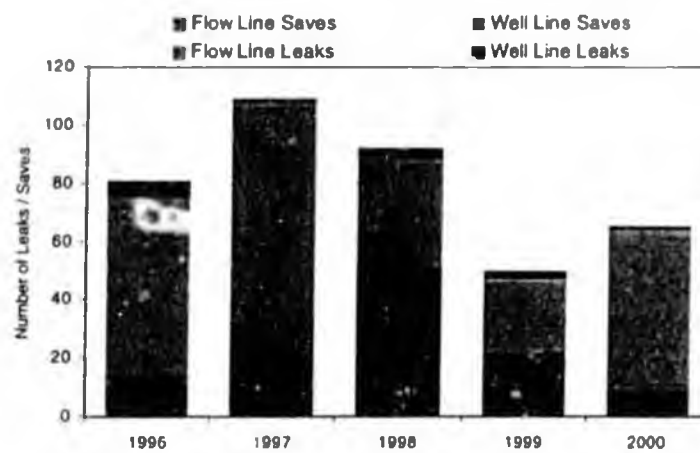

April 30th 2001

BP ADEC Meet and Confer Session 1

28



Alaska Consolidated Team Figure A1  
Corrosion coupon data from Endicott 1995-2000

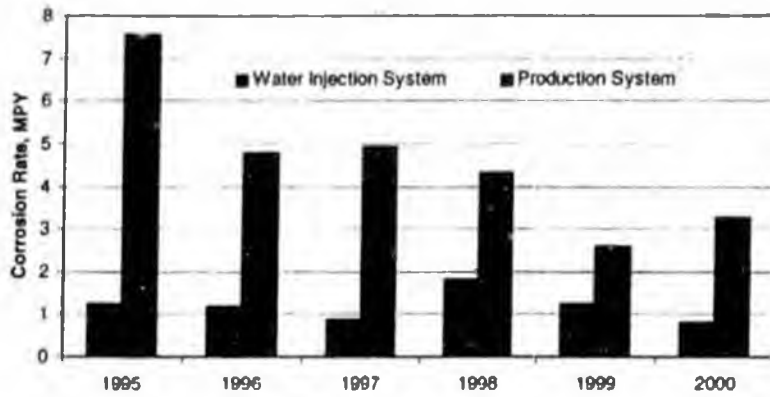

April 30, 2001

BP ADEC Meet and Confer Session 1

29



Alaska Consolidated Team Figure A2  
Corrosion coupon data from Milne Point 1995-2000

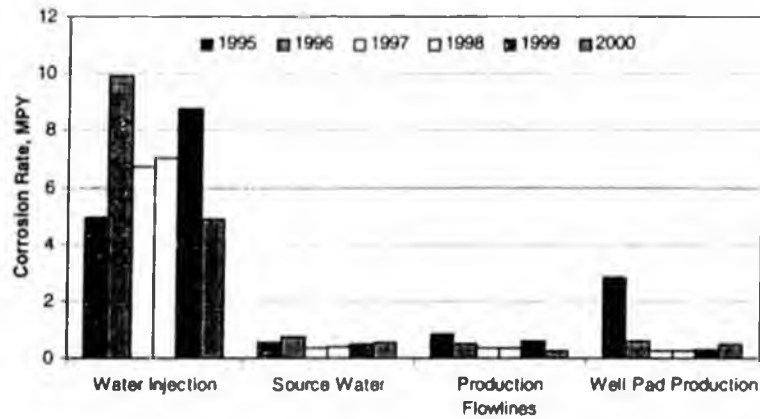

April 30th 2001

BP ADEC Meet and Confer Session 1

30



Alaska Consolidated Team Figure A3  
Endicott IIWL quarterly UT readings

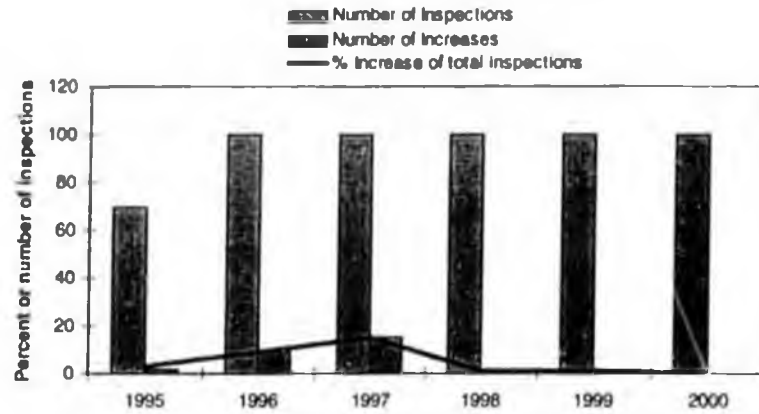

April 30th 2001

BP ADEC Meet and Confer Session 1

31



Alaska Consolidated Team Figure A4  
Endicott Velocity Monitoring

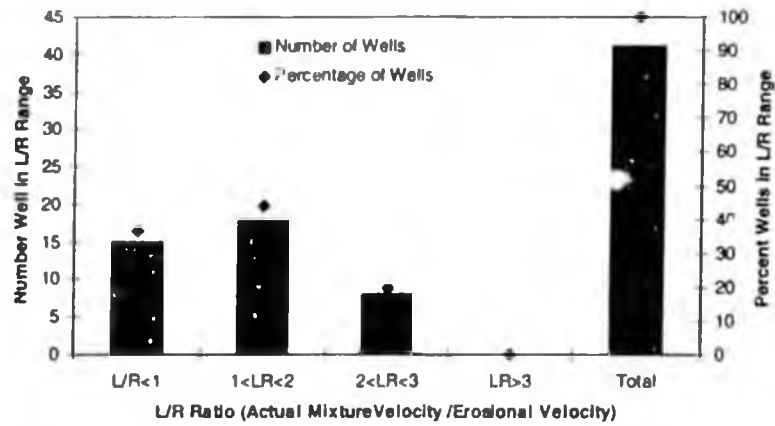

April 30th 2001

BP ADEC Meet and Confer Session 1

32



Alaska Consolidated Team Figure A5  
Detection of internal corrosion of well lines at Endicott

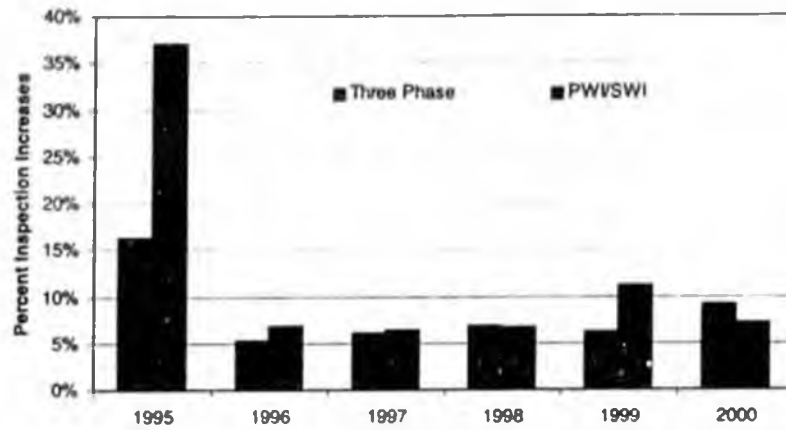

April 30th 2001

BP ADEC Meet and Confer Session 1

33



Alaska Consolidated Team Figure A6  
Detection of internal corrosion of cross country pipelines at Endicott

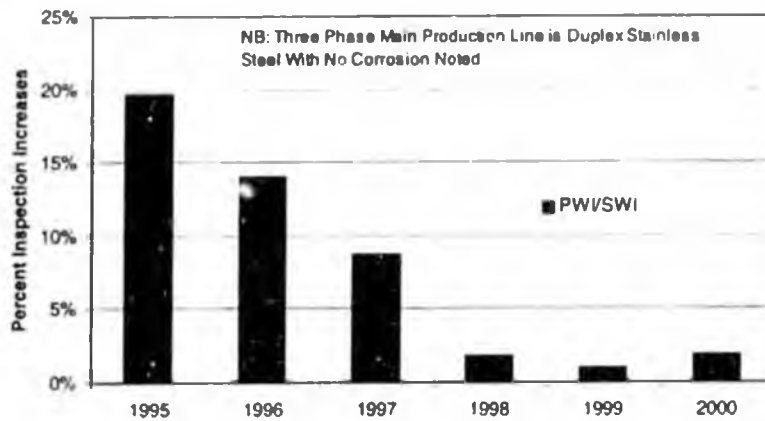

April 30th 2001

BP ADEC Meet and Confer Session 1

34



### Greater Prudhoe Bay Tables 1 to 2

Table 1: Summary of Well Pad / Drill Site Pipelines

Service	No. of Lines	Miles of Piping	No. of Internal Inspections	No. of External Inspections
Gas Injection	35	3	0	72
Miscible Injection	107	18	12	389
3 Phase Production	1088	268	6956	3192
Gas LR	675	160	15	2537
PW/SWAG Inj	180	42	2998	1442

Table 2: Summary of Cross Country Pipelines

Service	No. of Lines	Miles of Piping	No. of Internal Inspections	No. of External Inspections
Fuel Gas	7	22	0	0
Gas Transport	12	38	3	0
Gas Injection	7	10	0	35
Gas LR Supply	40	121	7	101
Miscible Injection	27	61	23	117
NGL	4	11	0	0
Nitrogen Storage	1	12	0	0
3 Phase Production	153	333	9,361	3,759
Export Oil	2	13	239	17
PW/SW	33	103	816	553

April 30th 2001

BP ADEC Meet and Confer Session 1

35



### Greater Prudhoe Bay Tables 3 to 4

Table 3: Smart pig Inspections

Year	Tool diameter(s)	No. of Lines	Lines Inspected
1995	14", 16", 20", 24"	14	A-74, D-36, E-36, F-74, H-36, J-74, K-74, M-69, M-74, N-74, S-69, U-384, X-74, XF-21
1996	24"	1	GLT-24
1997	24"	6	B-36, S-36, W-74, X-74, Y-36/74, Z-74
1998	12", 34"	3	OT, U-69, Y-69
1999	24"	6	A-74, E-36, F-74, J-74, M-74, N-74
2000	16", 24"	5	D-36, H-74, K-74, U-384, XF-21

Table 4: Number of Corrosion Monitoring Coupons

Year	Cross country	Well Lines	PW	SW	GL & Inj	Total
1995	1,324	6,195	1,125	750	4	9,536
1996	1,489	7,676	1,140	744	10	11,193
1997	1,467	7,784	1,207	968	10	11,574
1998	1,490	7,582	1,138	732	10	11,094
1999	1,425	6,875	1,010	782	10	10,238
2000	1,371	5,855	816	782	10	8,970

April 30th 2001

BP ADEC Meet and Confer Session 1

36



### Greater Prudhoe Bay Tables 5 to 6

Table 5: Corrosion Monitoring Probes

Location	No. of Probes
Well lines	78
Cross Country pipelines	84

Table 6: Corrosion Inhibitors used across Greater Prudhoe Bay

Supplier	Chemical	1996	1997	1998	1999	2000
Nalco Exxon	EC1110A					
Nalco Exxon	EC1259					
Nalco Exxon	87VD129					
Nalco Exxon	86VD118					
Nalco Exxon	90VD048					
Champion	RU223					
Champion	RU210					
Champion	RU256					
Champion	RU-271					
Champion	125A					
Champion	RU256*					

April 30th 2001

BP ADEC Meet and Confer Session 1

37



### Greater Prudhoe Bay Tables 7 to 8

Table 7: Water production, corrosion inhibitor usage and concentration

Year	Water production (million barrels)	Inhibitor Usage (million gallons)	Concentration (ppm)
1996	458.4	2.05	106
1997	458.3	2.21	115
1998	426.0	2.53	141
1999	415.7	2.28	130
2000	436.3	2.73	149

Table 8: Recurring Frequency of CUI Inspection Surveys

Equipment Temperature	Interval Between Examinations (Years)
≤80° F	10
>80 - 120° F	8
>120 - 150° F	6
>150° F	4

April 30th 2001

BP ADEC Meet and Confer Session 1

38

Greater Prudhoe Bay Tables 9 to 10



Table 9: Electromagnetic Inspections

	No. of Cased Pipe Segments	Footage Tested	No EM Anomalies	EM Anomalies	Significant EM Anomalies
Gas/Gas Lift	88	7,249	75	13	0
Miscible Injection	31	2,196	28	3	0
NGL	2	255	1	1	0
3 Phase Production	82	6,655	67	13	2
Oil Export	1	75	1	0	0
PW/SW/WAG	32	2,771	25	7	0

Table 10: Guided Wave Inspections

	No. of Cased Pipe Segments	Footage Tested	No Significant Indications	Minor Anomalies	Moderate Anomalies	Severe Anomalies
Gas/Gas Lift	26	2,643	24	2	0	0
Miscible Injector	1	42	1	0	0	0
NGL	5	728	4	1	0	0
3 Phase Production	16	1,342	13	3	0	0
PW/SW	27	2,604	22	3	2	0

April 30th 2001

BP ADEC Meet and Confer Session 1

39

Greater Prudhoe Bay Table 11 to 12



Table 11: Mechanical Repairs Installed

Service	Internal	External
Cross country	1	1
Production well line	6	18
Lift Gas	0	3
PWI	0	6

Table 12: Leaks due to corrosion

Service	Location	Date	Internal/External	Volume
3 phase production	S pad	6/18/00	External	50 gals
Gas lift	DS 09	9/2/00	External	0

April 30th 2001

BP ADEC Meet and Confer Session 1

40

Greater Prudhoe Bay Tables 13 to 14



Table 13: Leaks and Saves

Year	Cross Country Saves	Well Line Saves	Cross Country Leaks	Well Line Leaks	Cross Country Leak Save	Well Line Leak Save	Overall Leak Save
1996	14	57	4	8	78%	90%	88%
1997	33	73	2	1	94%	99%	97%
1998	51	34	3	4	94%	89%	92%
1999	22	25	0	3	100%	80%	94%
2000	9	54	1	1	90%	98%	97%

Table 14: Planned Coupon | Schedule for Greater Prudhoe Bay

Service	Cross Country (months)	Well Line (months)
3 phase production	3	4
Produced water	6	8
Sea water	3	4
NGL	3	N/A
Sales Oil	3	N/A

April 30th 2001

BP ADEC Meet and Confer Session 1

41

Alaska Consolidated Team Tables A1 to A2



Table A1: Endicott Summary of Lines and NDT Inspections

Service	Miles of Piping	No. Internal Inspections	No. External Inspections
Oil x-country lines	3.5	4 (in vault)	4 (in vault)
Oil - Well Pads	2.5	1112	0
Water x-country lines	3.5	104	4 (in vault)
Water - Well Pads	1.7	101	2 (in vault)
Gas x-country (GLT/M)	7	4 (in vault)	4 (in vault)
Gas - Well Pads	1.2	21	2 (in vault)

Table A2: Milne Point Unit Summary of Lines and NDT Inspections

Service	Miles of Piping	No. Internal Inspections	No. External Inspections
Oil x-country lines	24	15	41
Oil - Well Pads	Note	497	138
Water x-country	15	95	51
Water - Well Pads	Note	812	150
Gas x-country	14	0	0
Gas - Well Pads	Note	0	0

Note: Data not immediately available

April 30th 2001

BP ADEC Meet and Confer Session 1

42

Alaska Consolidated Team Tables A3 to A4



Table A3: Badami Summary of Lines and NDT Inspections

Service	Feet of Piping	No. Internal Inspections	No. External Inspections
Oil - Well Pad	840'WL, 320' HDR	21 well line, 4 Header	0
Gas	240'WL, 320' HDR	8 well line, 4 header	0
Disposal Well	400'	6 well line	0

Note: Badami does not have an active water injection system

Table A4: Endicott Corrosion Coupon Monitoring 2000

System	Number of Locations with Access Fittings	% Coupons < 2MPY Corrosion Rate
Water Injection - Pads	15	100%
Water Injection - s-country	1	100%
Oil Production - Pads	81	64%

April 30th 2001

BP ADEC Meet and Confer Session 1

43

Alaska Consolidated Team Tables A5 to A8



Table A5: MPU Corrosion Coupon Monitoring 2000

System	Number of Locations with Access Fittings	% Coupons < 2MPY Corrosion Rate
Production System Pads	11	91%
Production System s-country	19	100%
Water Injection System	6	33%
Source Water Coupons	3	100%

Table A8: MPU Inspection Summary- External

Inspection Year	Total Inspections - External	Total Repeat Inspections	Total Increases	Percent Increase
1997	26	0	0	n/a
1998	441	10	0	0.0
1999	101	65	0	0.0
2000	205	104	28	26.9

April 30th 2001

BP ADEC Meet and Confer Session 1

44

Alaska Consolidated Team Tables A9 to A10



Table A9: MPU Inspection Summary- Electromagnetic External Inspections

	No. of Cased Pipe Segments	Footage Tested	No EM Anomalies	EM Anomalies	Significant EM Anomalies
Gas/Gas Lift	3	256	2	1	0
Production	3	253	1	2	0
PW/SW/WAG	3	222	1	2	0
Source Water	1	82	0	1	0

Table A10: MPU Inspection Summary - Internal

Inspection Year	Total Inspections - Internal	Total Repeat Inspections	Total Increases	Percent Increase
1994	332	0	0	n/a
1995	6	0		n/a
1996	13	0		n/a
1997	632	72	20	27.8
1998	994	276	33	12.0
1999	931	72	5	6.9

April 30th 2001

BP ADEC Meet and Confer Session 1

45

Alaska Consolidated Team Tables A11 to A12



Table A11: Endicott Leak / Save and Mechanical Repair Data

Service	# of Leaks	# of Saves	# of Sleeves	Comments
Oil x-country lines	0	0	0	
Oil Well Pads	1	2	0	1-45 S-rear Save, 1-63 S-spool Save, 2-04 S-spool leak.
Water x-country lines	0	1	0	MPI PW Header Blind flange and valve replaced.
Water Well Pads	0	0	0	
Gas x-country GLT/M	0	0	0	
Gas Well Pads	0	0	0	

Note: Leak / Save and mechanical repair data is for year 2000 only

Table A12: Milne Point Leak / Save & Mechanical Repair data

Service	# of Leaks	# of Saves	# of Sleeves	Comments
Oil x-country	1	3	0	In plant ORT piping only
Oil Well Pads	0	0	0	
Water x-country	0	0	0	
Water Well Pads	0	0	0	
Gas x-country	0	0	0	
Gas Well Pads	0	0	0	

Note: Leak / Save and mechanical repair data is for year 2000 only

April 30th 2001

BP ADEC Meet and Confer Session 1

46

Alaska Consolidated Team Table A13



Table A13: Badami Leak / Seve and Mechanical Repair Data

Service	# of Leaks	# of Seves	# of Sleeves	Comments
Oil - Well Pad	0	0	0	
Gas - Well Pad	0	0	0	
Disposal Well	0	0	0	

Note: Leak / Seve and mechanical repair data is for year 2000 only

April 30th 2001

BP ADEC Meet and Confer Session 1

47

North Slope Map

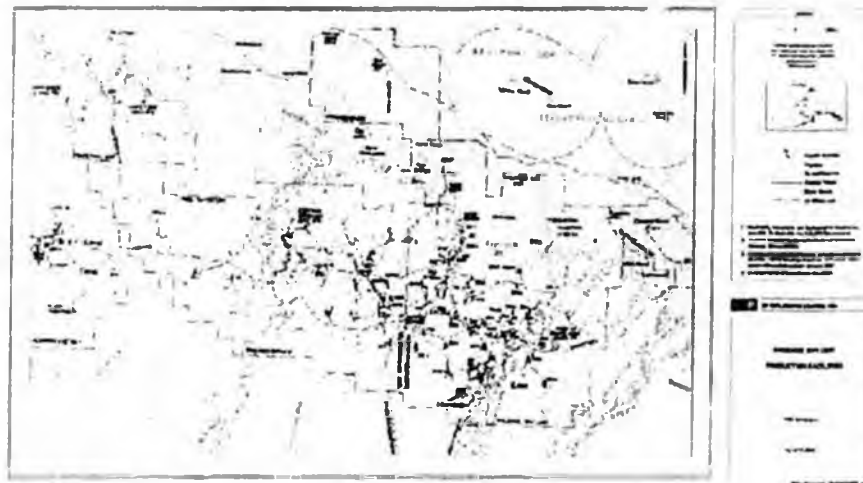

April 30th 2001

BP ADEC Meet and Confer Session 1

48



### Facilities Schematic

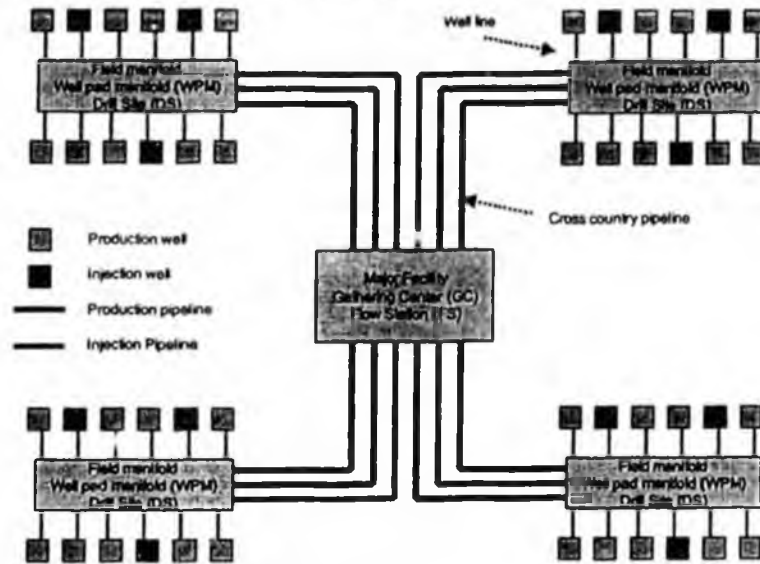

April 30th 2001

BP ADEC Meet and Confer Session 1

49

CPA



---

# Greater Kuparuk Area

## Corrosion Programs

### Overview

presented to the

Alaska Department of Environmental Conservation

April 30, 2001

- **Effective corrosion management is critical:**
  - ≈ Safety & Environmental exposure
  - ≈ Asset preservation (\$)
  - ≈ Minimize downtime/lost production
  
- **Corrosion Factors**
  - ≈ Aging of field infrastructure
  - ≈ Corrosivity of produced fluids increasing (due to CO<sub>2</sub> production & H<sub>2</sub>S)
    - water production
    - H<sub>2</sub>S
  
- **Over \$4 Billion in assets**
  - ≈ 530 miles of insulated pipelines
    - 60 miles well lines (900+ wells)
  - ≈ 237 cross country lines
  - ≈ 750 road crossings
  - ≈ 100,000+ weld-packs

# Overview

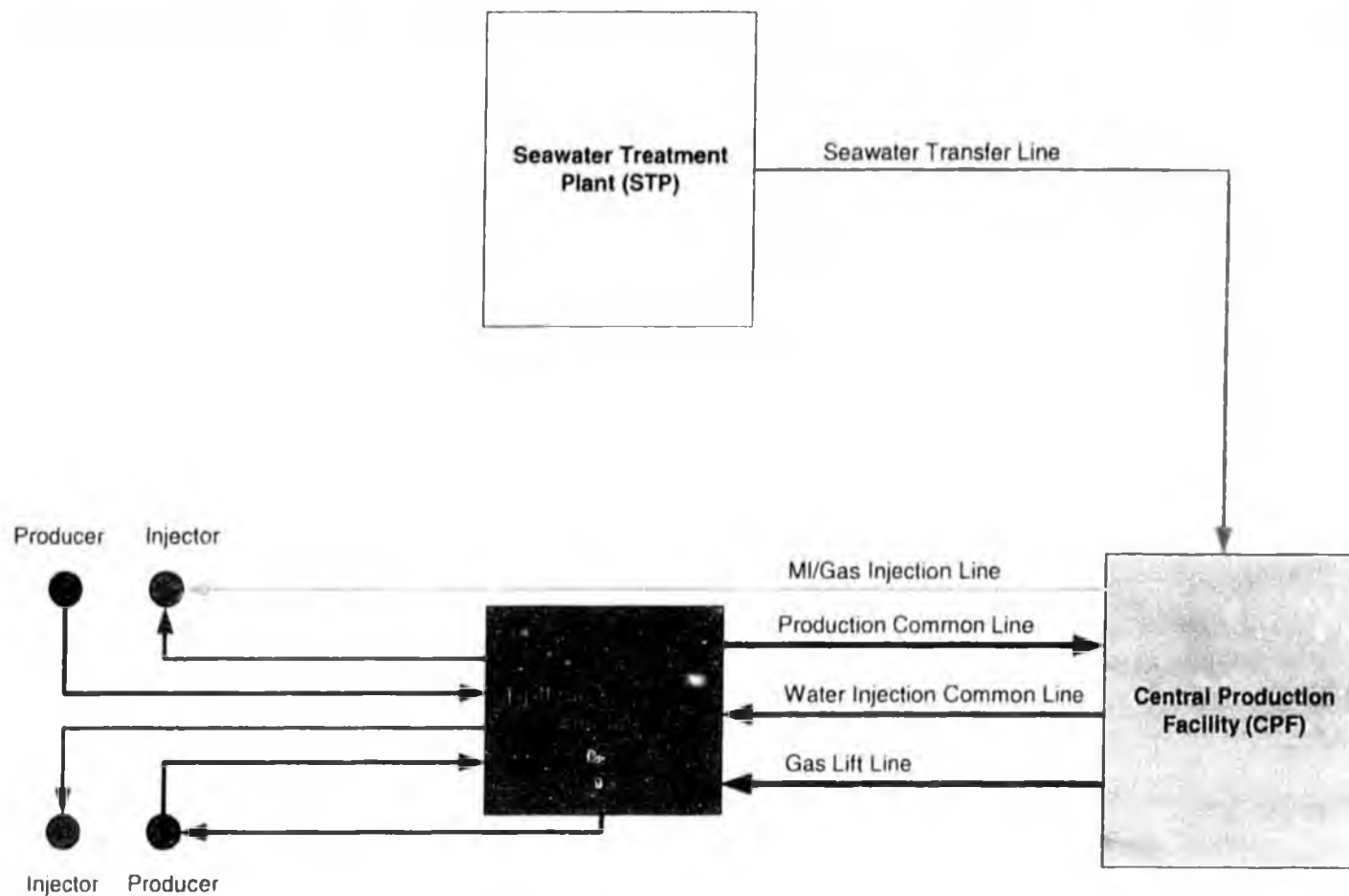

“Well Lines”

“Cross Country Lines”

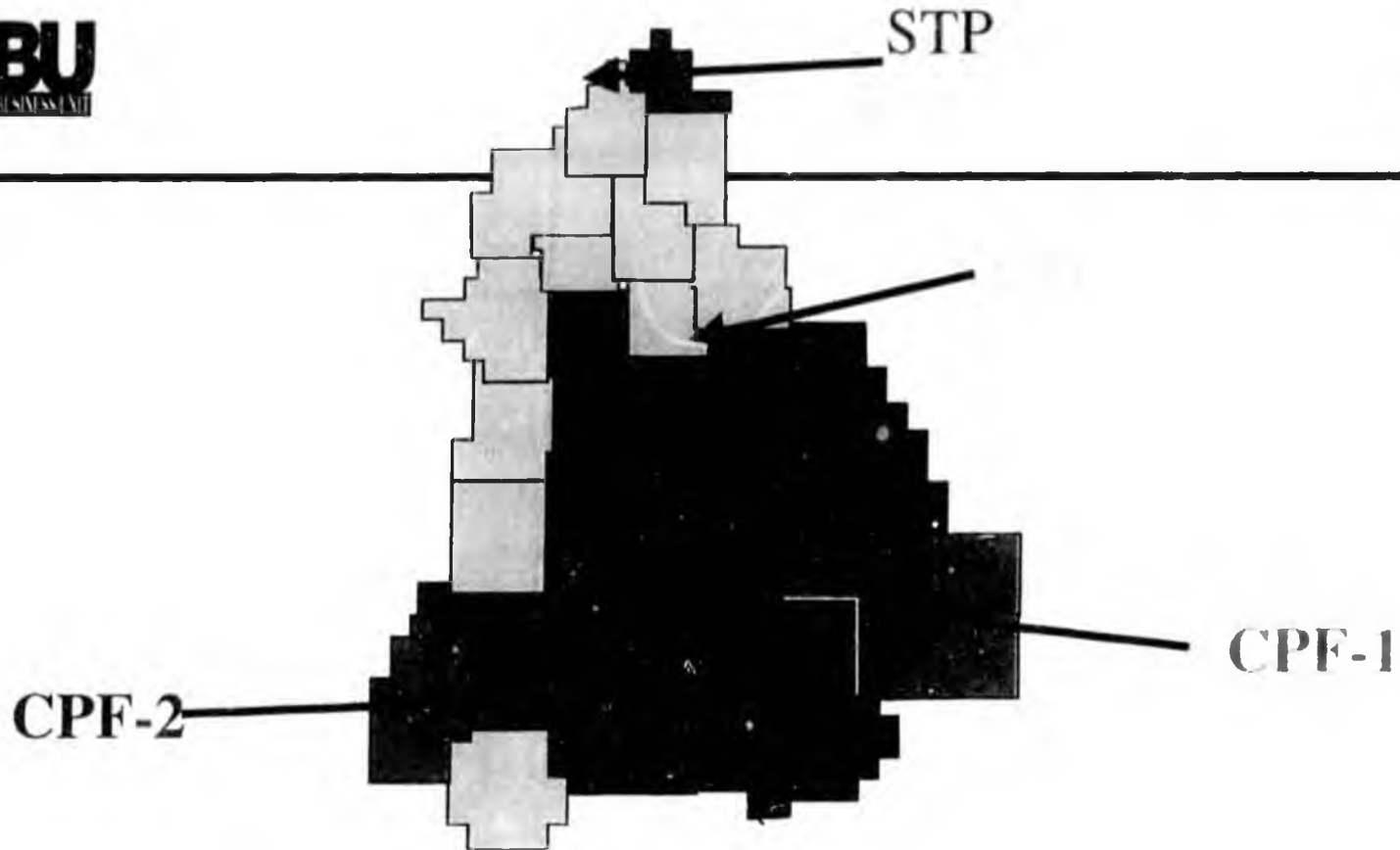

## Start up Timing

- 1981
- 1982-1985
- 1986-1990
- 1991-1995



TALW

## Historical Overview

## Mechanisms

- Internal Corrosion
  - ≈ Erosion Corrosion
  - ≈ Under Deposit Corrosion
  - ≈ Microbially Induced Corrosion (MIC)
- External Corrosion
  - ≈ Corrosion Under Insulation (CUI)

## Methods

- Monitoring
  - ≈ Coupons
  - ≈ Probes
- Mitigation
  - ≈ Chemical Inhibition
  - ≈ Mechanical Pigging
- Inspection
  - ≈ Radiography
  - ≈ Ultrasonics
  - ≈ Corrosion Rate Monitoring (CRM)

- ELECTROCHEMICAL / ULTRASONIC  
- Smart pigging - 1 hr on line  
1 hr on line

- ① Use **chemical inhibitors** as primary means of control
- ② Monitor **corrosivity** of system to provide feedback and allow effective resource management
- ③ Implement **risk-based inspection** to provide feedback and prevent leaks *priority inspection*
- ④ Increase understanding of Corrosion Mechanisms through **data analysis**
- ⑤ Pursue **technology improvements** in chemicals and inspection to increase efficiencies

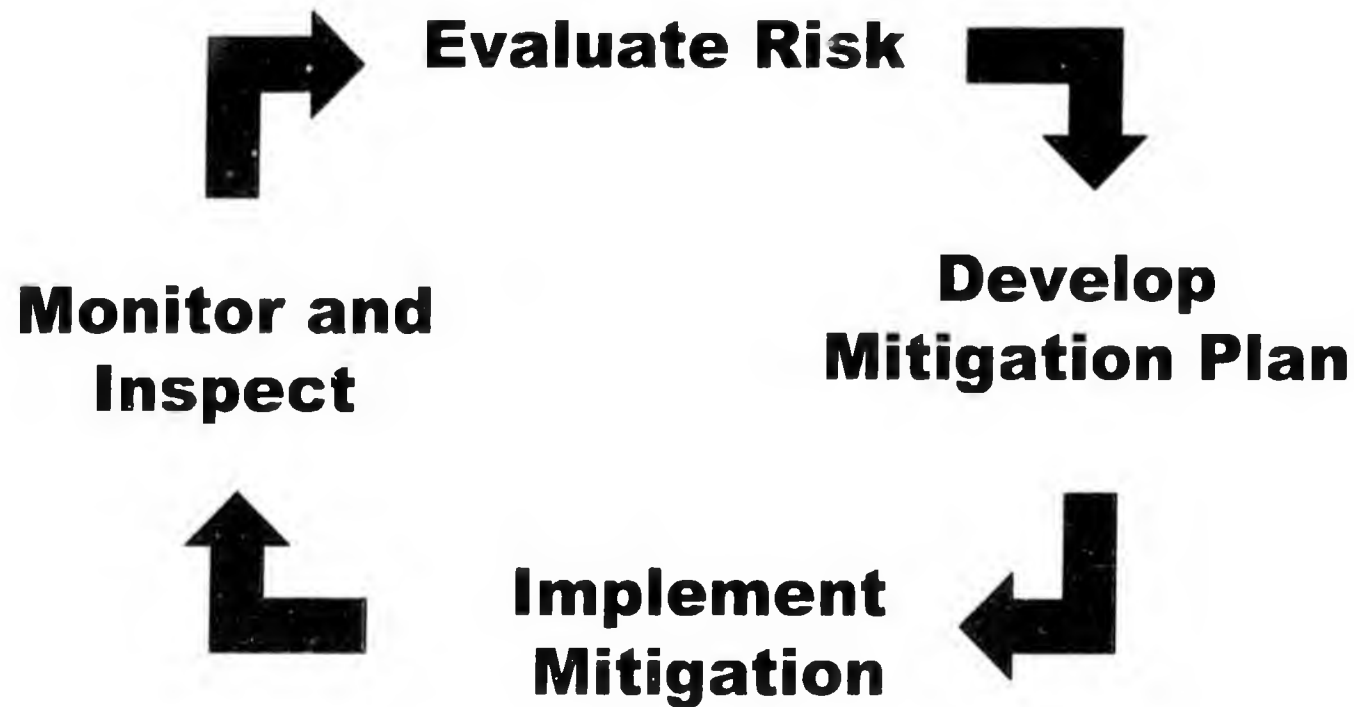

- ✓ Identifies changes/trends in corrosivity of system
- ✓ Optimization tool for chemical inhibition and inspection programs
- **Electrical-Resistance Probes**
  - ⇒ Short-term Feedback; can identify transient corrosion events
  - ⇒ May not accurately reflect general pipewall corrosion rates
- **Coupons** >1100 locations
  - ⇒ Longer-Term Feedback; average corrosivity over time period
  - ⇒ Better correlation with general pipewall corrosion rates
- **Inspection Data**
  - ⇒ Identify and track actual corrosion damage
  - ⇒ Measures actual pipewall corrosion rates, but after damage is done

# Monitoring

## Kuparuk Inhibitor Feedback System

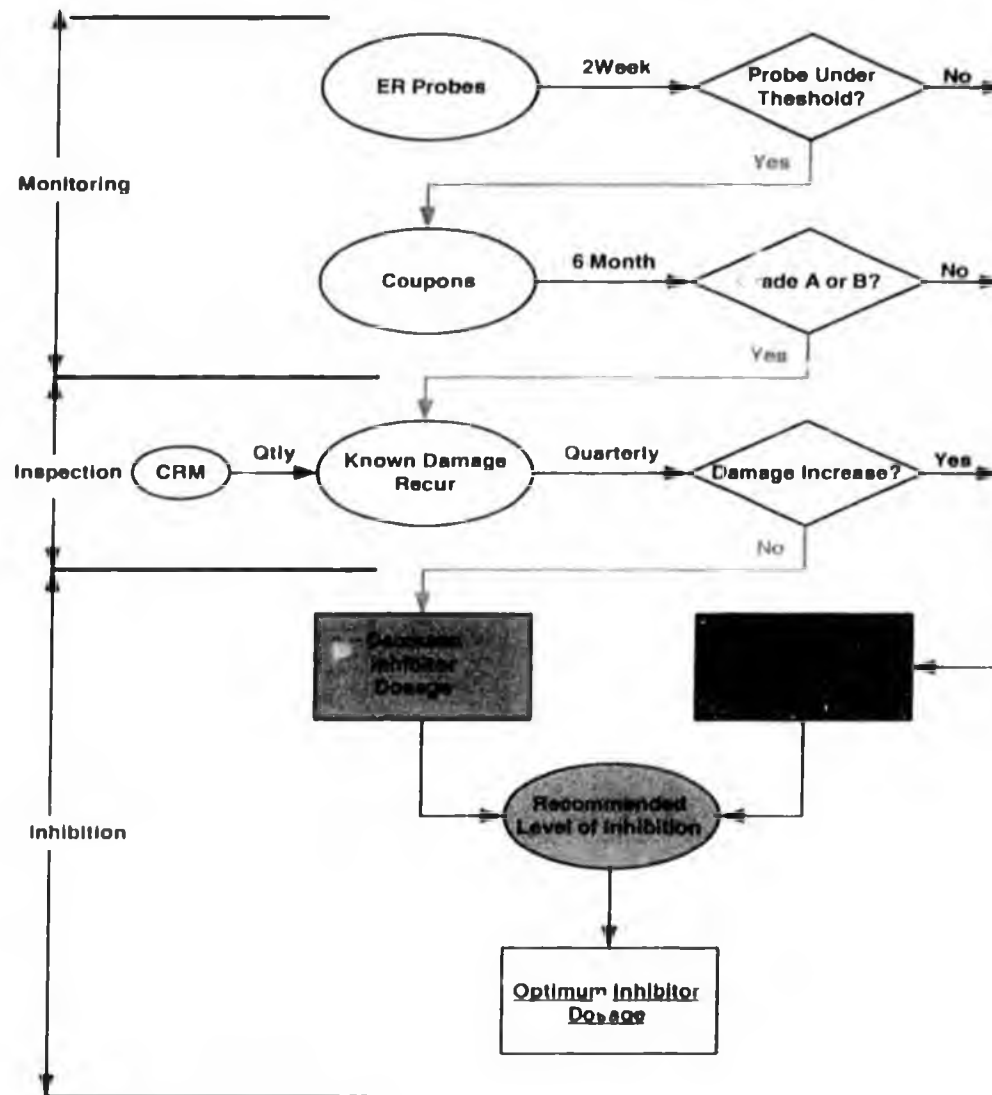

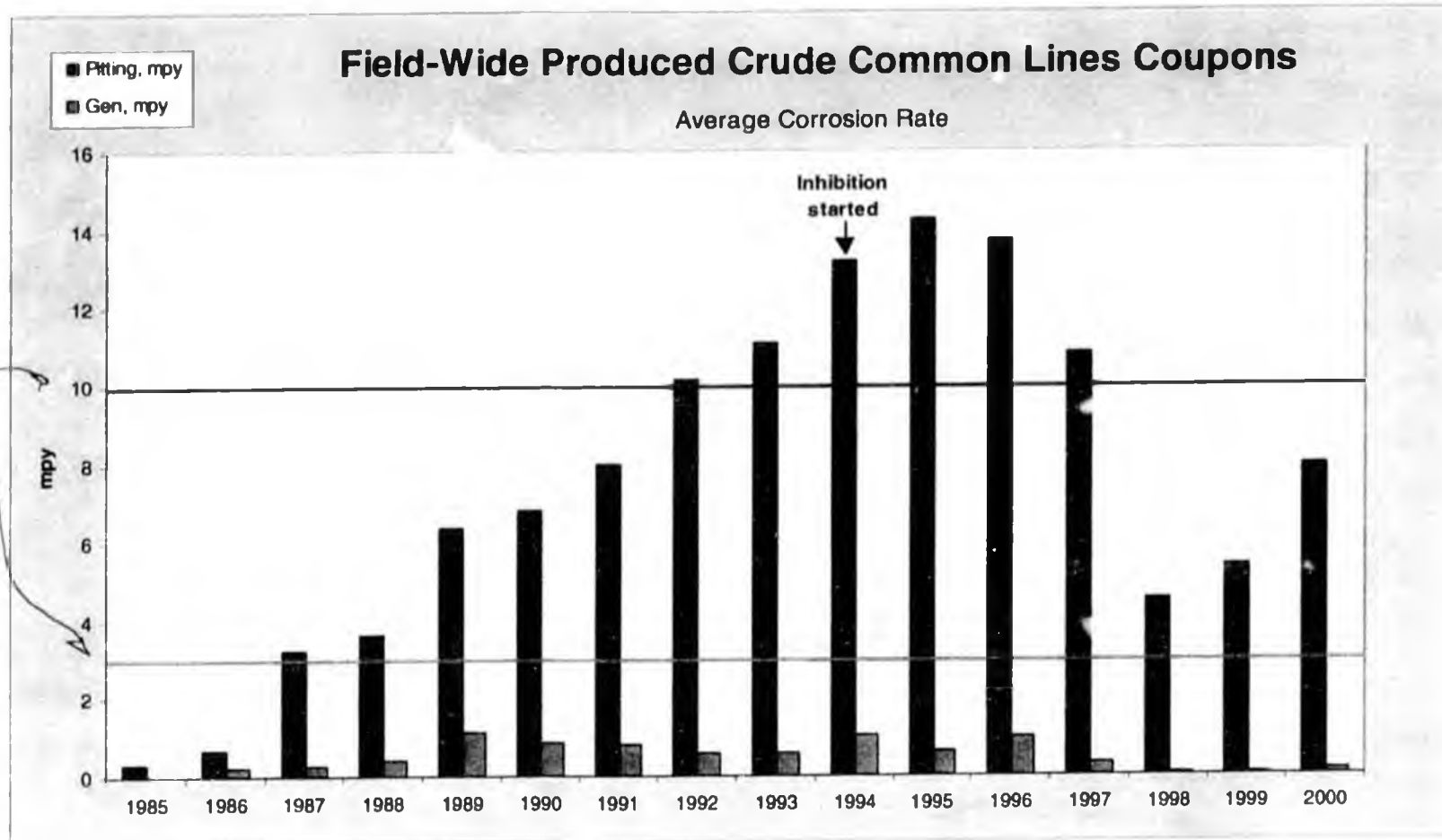

- Probes, Year 2000: Average Rate <1 mpy
- Inspection data indicates corrosion is under control

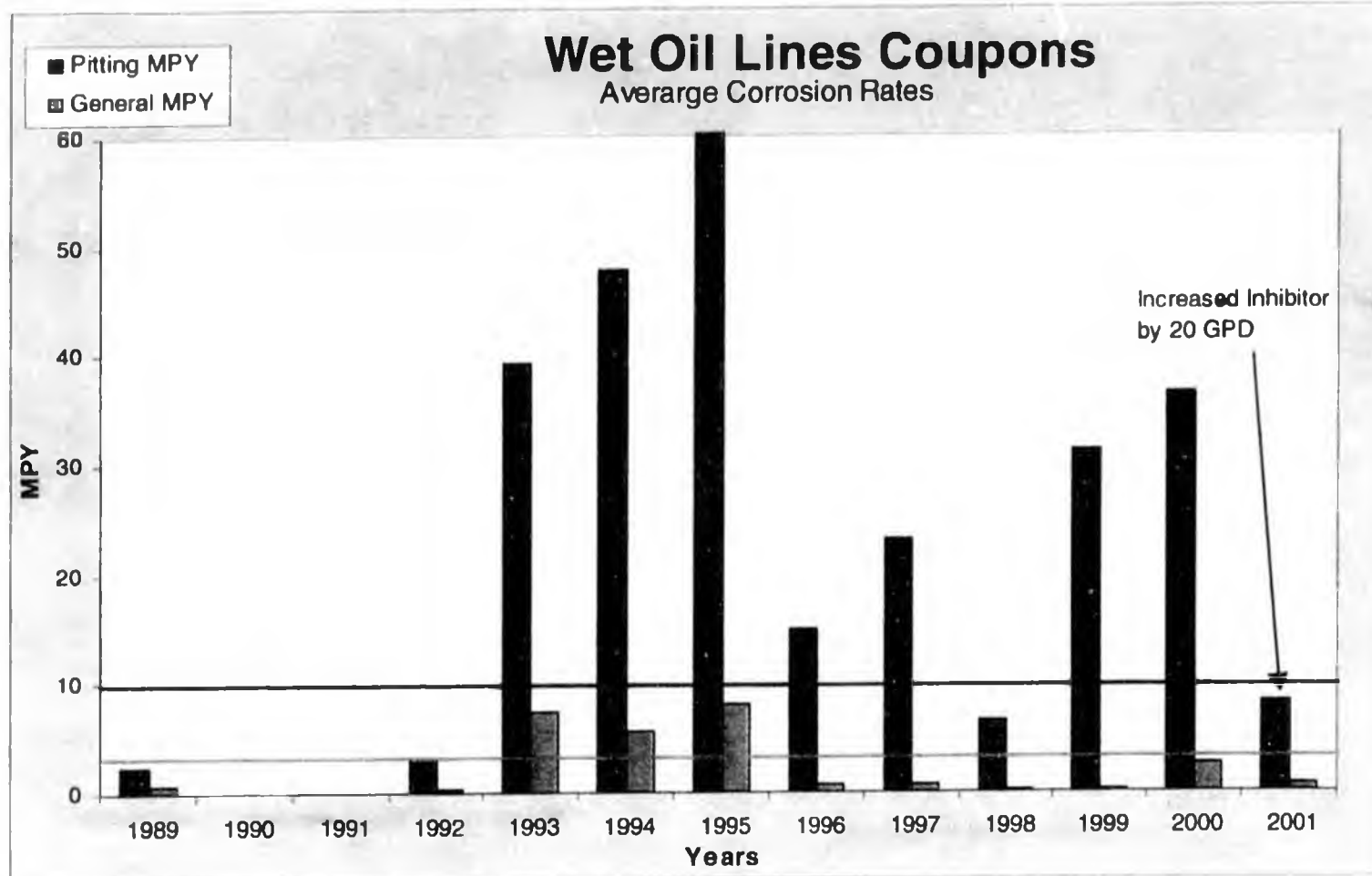

- > Year 2000 average pitting rate of 36 mpy including 24" line
- > Year 2000 average pitting rate of 11 mpy for 16" line & 12" line
- > 24" WO Line scheduled for decommissioning in June 2001

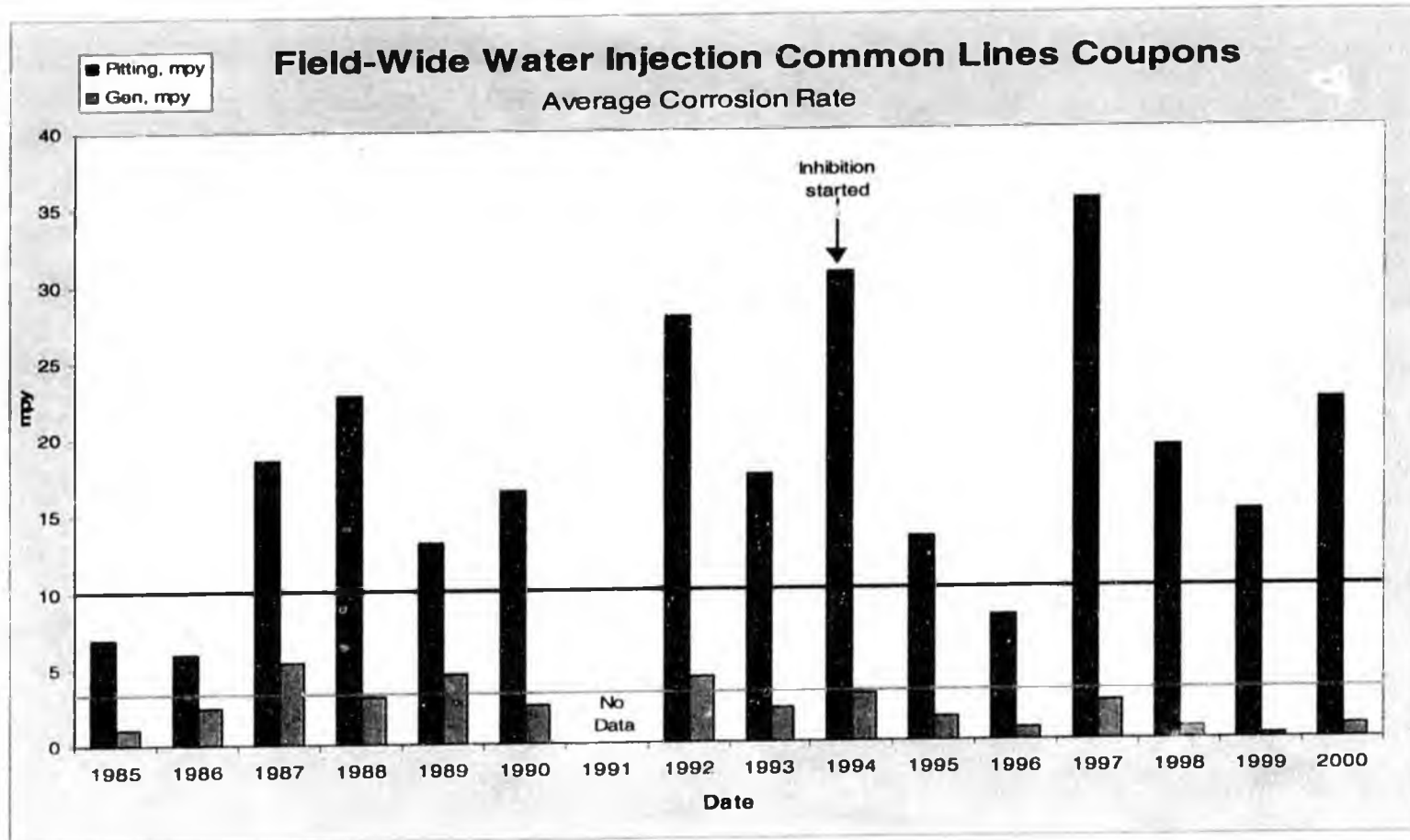

- Inspection data indicates that corrosion activity localized in stagnant, un-piggable sections of line
- Corrosion rate increasing as injection source water is mixed

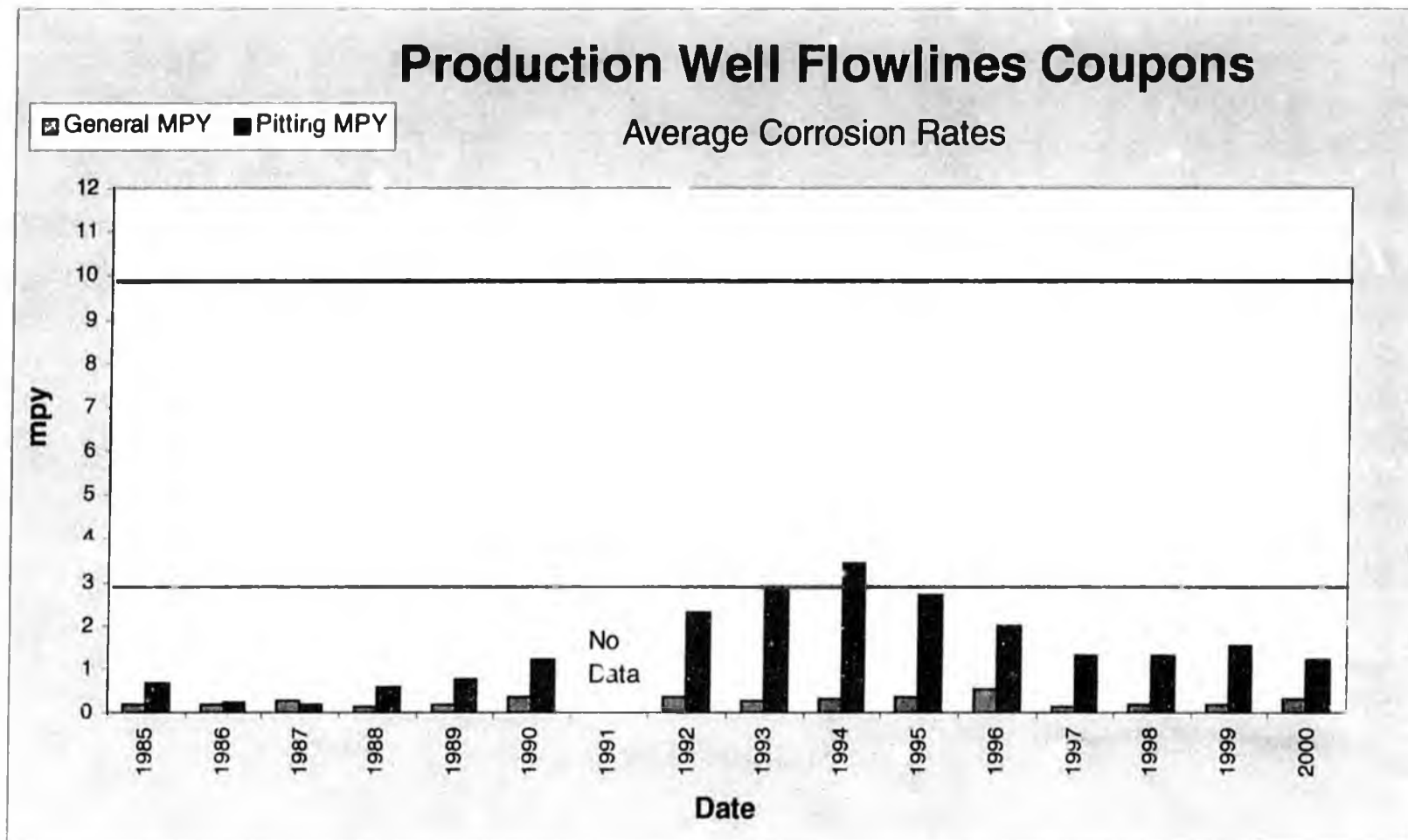

➤ Inspection data suggests that actual pipewall corrosion rates are higher

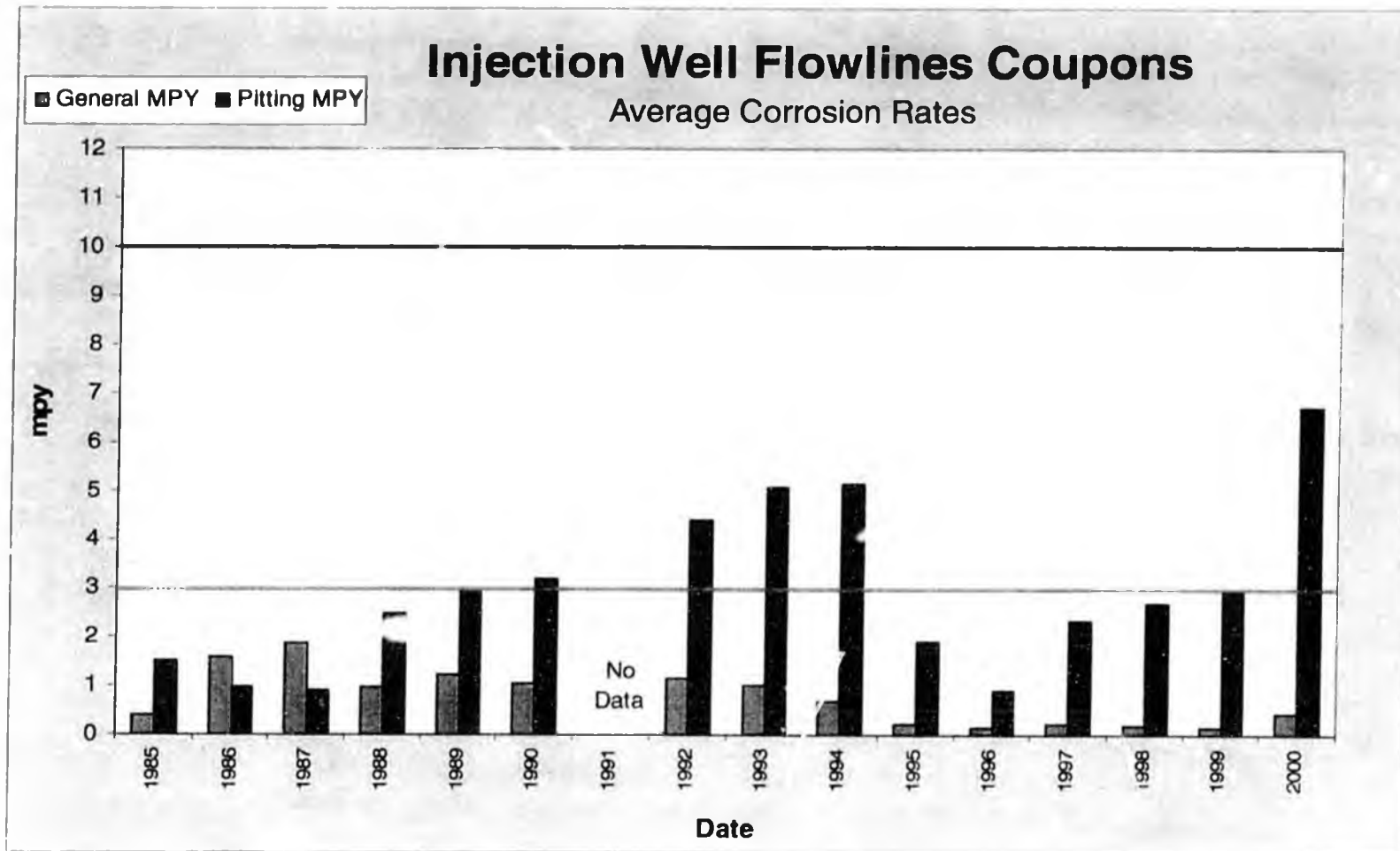

➤ Inspection data suggests that actual pipewall corrosion rates are higher



# Mitigation



- Over \$8MM/year spent on corrosion chemicals
- Continuously search for better chemistry
  - ≈ Vendor Proposals
  - ≈ Laboratory Testing
  - ≈ Field Testing
  - ≈ Full-field Implementation
- ✓ New inhibitor, Cortron 2000-25, scheduled for full-field implementation in 1st half 2001
- ✓ First stage (3-5 Drill Sites) of wellhead chemical inhibition facilities scheduled for start-up in 2001
- ✓ 24" Wet Oil Line decommissioning in 2001



# Inspection



## ➤ Internal Corrosion Surveillance

- ≈ Real-Time Radiography (RTR)
- ≈ Manual Radiography (RT)
- ≈ Ultrasonics (UT)
- ≈ Corrosion Rate Monitoring (CRM) - Uses UT at discrete locations to provide feedback for Inhibitor Optimization System

## ➤ External Corrosion Surveillance

- ≈ Tangential Radiography (TRT)
- ≈ Automated Tangential Radiography (ATRT)

## ➤ Below-Grade Piping Program

- ≈ PTI - Electromagnetic wave pulse system
- ≈ TWI - Guided ultrasonic wave system



# Inspection - Internal Corrosion

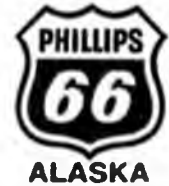

## Year 2000

### ➤ Well Lines

- ✓ Approximately 1000 well lines at Kuparuk
- ✓ inspected 21,000 feet on 70 well lines using RTR
- ✓ 2,650 RT inspections on 297 well lines; 20 increases
- ✓ 4,137 UT inspections on 277 well lines; 95 increases
- ✓ 358 baseline UT inspections on 156 well lines, done in conjunction with External (CUI) program
- ✓ 18 well lines required repair (8 injectors, 10 producers)



# Inspection - Internal Corrosion



## Well Lines

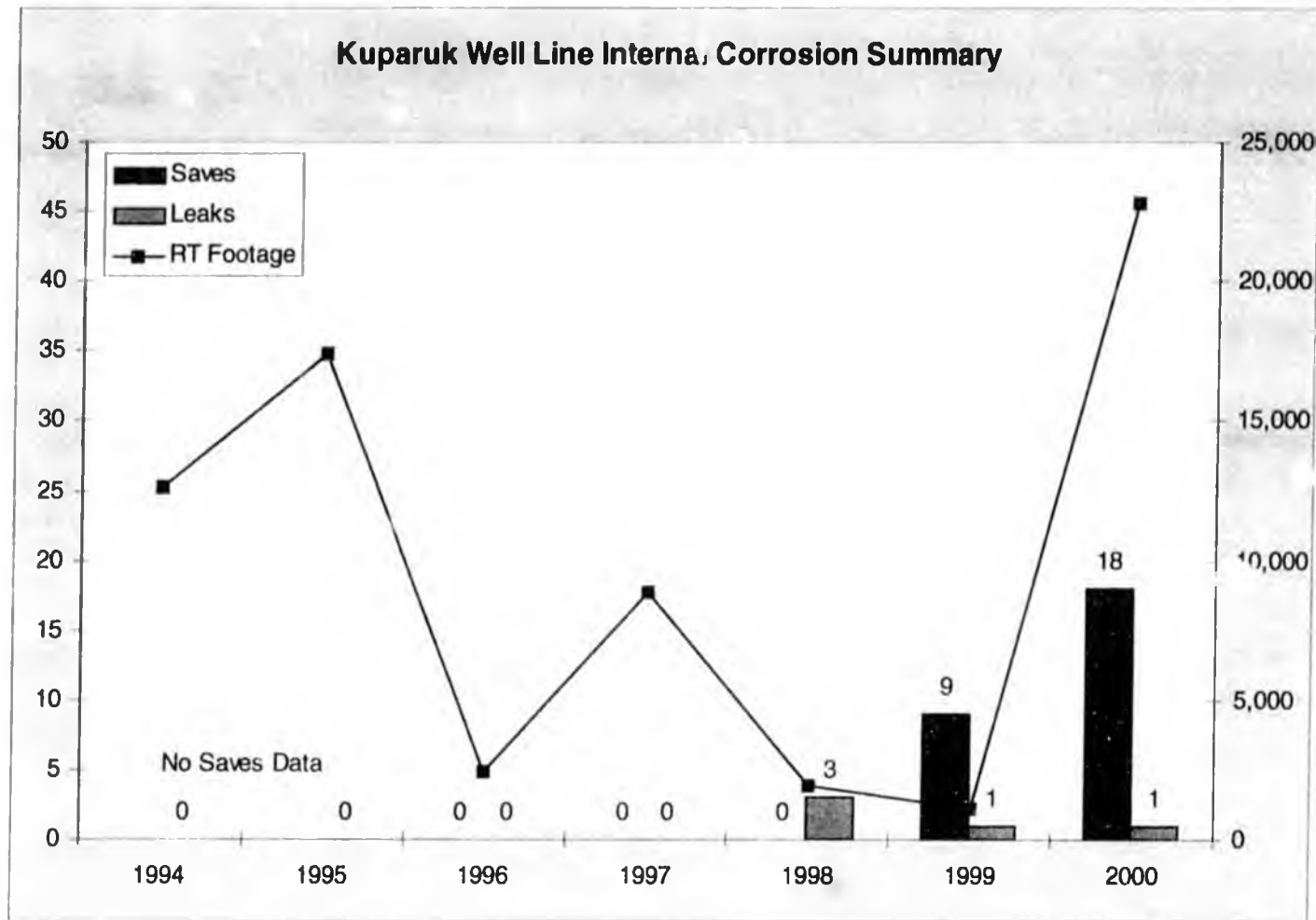



# Inspection - Internal Corrosion



*Year 2000*

## ➤ **Cross Country Lines**

- ✓ 237 cross-country lines at Kuparuk
- ✓ Inspected 21,200 feet on 16 CC lines using RTR
- ✓ 1,530 RT inspections on 101 CC lines; 1 increase
- ✓ 497 UT inspections on 43 CC lines; 12 increases
- ✓ 366 baseline UT inspections on 88 CC lines, done in conjunction with External (CUI) program
- ✓ 0 CC lines required repair



# Inspection - Internal Corrosion



## Cross Country Lines

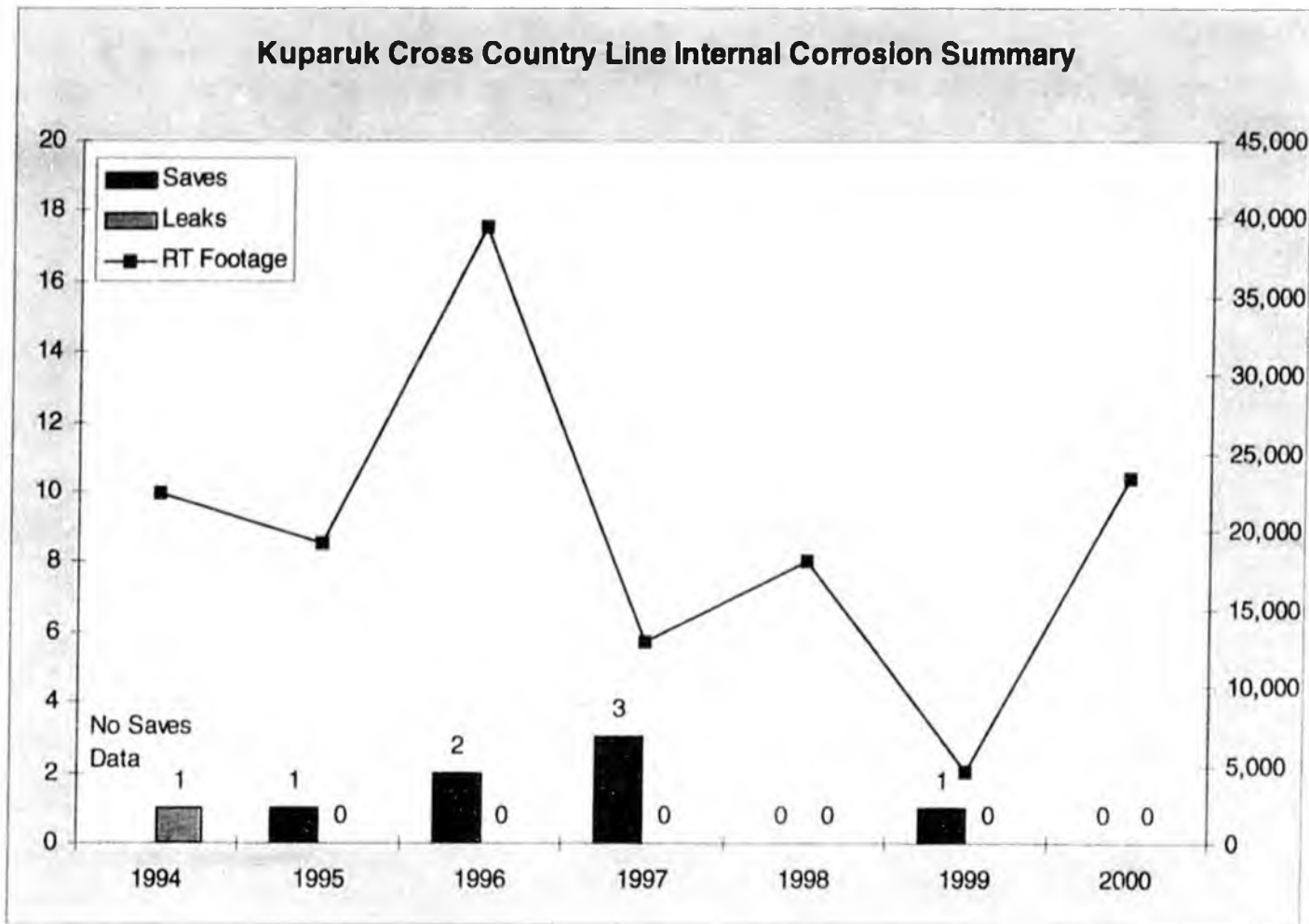



# Inspection - Internal Corrosion



**Year 2001 Forecast**

- ⇒ Increase RTR on well lines, decrease RTR on Cross Country lines
- ⇒ Prioritization of RTR has been adjusted to focus more on thin-walled, older lines, with less emphasis on service
- ⇒ Decrease “screening” RTR footage from 30% of total length to 20-25%; will increase number of lines inspected
- ⇒ Initiate “wandering can” inspection to confirm prioritization and look for anomalies
- ⇒ Implement a risk-ranked Elbow Program to increase effectiveness of Cross Country line inspections



# Inspection - External Corrosion



## Year 2000

### ➤ **Cross Country Lines, Off-Pad**

- ✓ Off-pad weld pack inspection 99.9% complete (50 left out of ~67,000 total)
- ✓ 5 repair locations in 2000
- ✓ Complete inspection of off-pad weld packs by end of 2001

### ➤ **Cross Country Lines, On-Pad**

- ✓ On-pad weld pack inspection 30% complete (out of ~10,500 total)
- ✓ Complete inspection of on-pad weld packs by end of 2004

### ➤ **Well Lines**

- ✓ Weld pack inspection ~25% complete (out of ~24,000 total)
- ✓ 3 repair locations in 2000
- ✓ Complete inspection of well line weld packs by end of 2005



# Inspection - External Corrosion

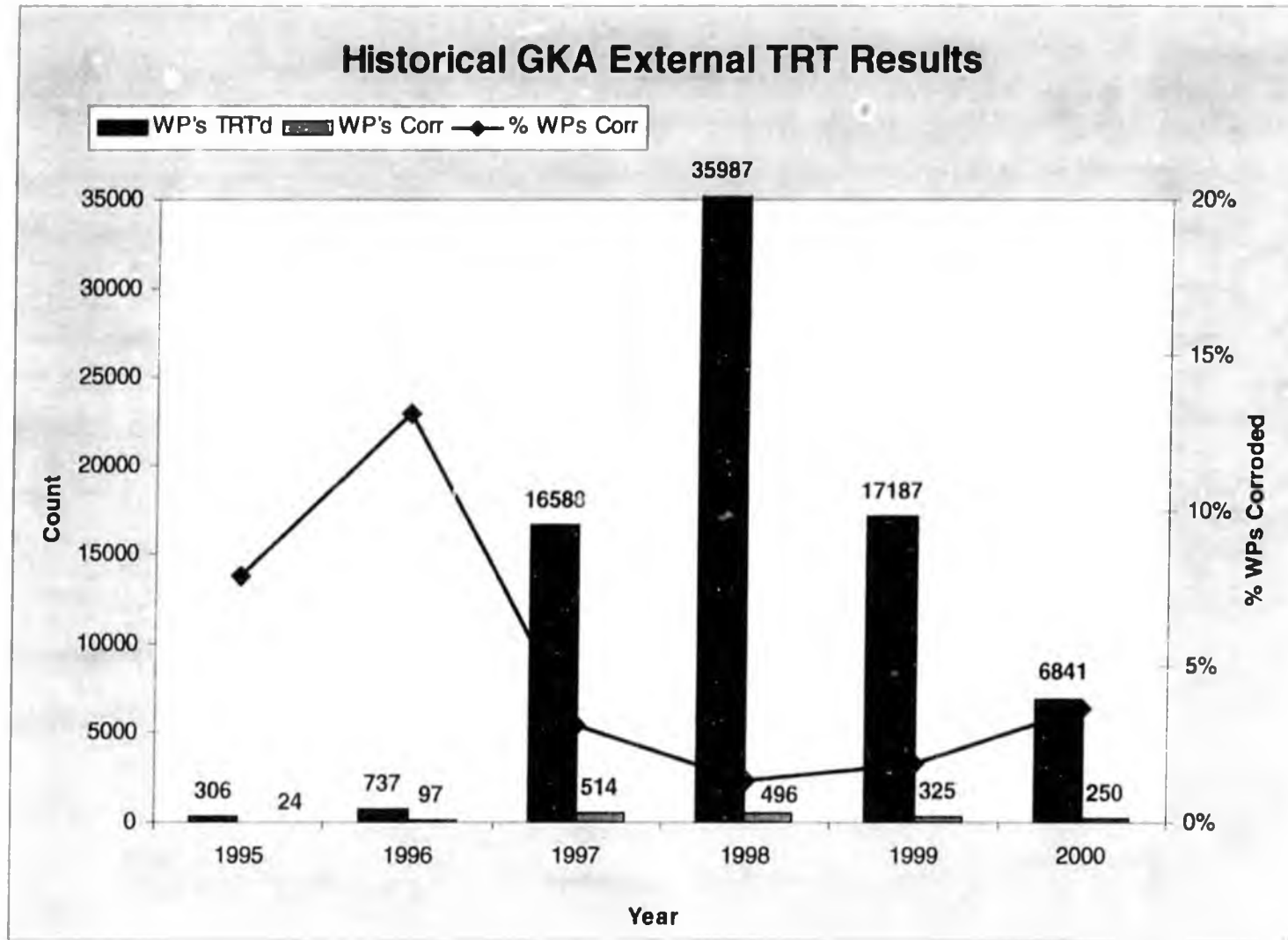

**External Inspections - Last 15 Months (On Pad Piping)**

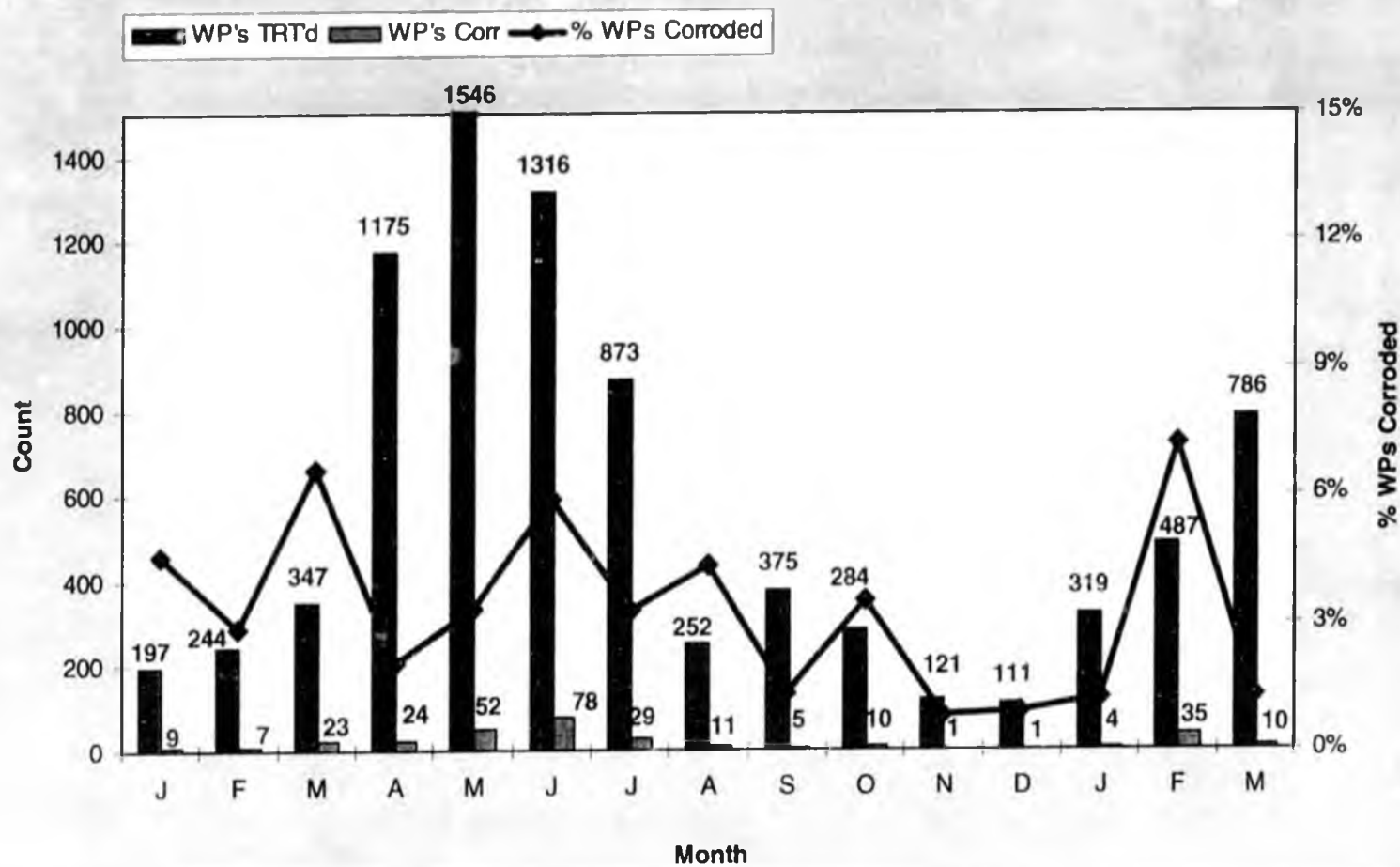



# Inspection - External Corrosion



## Historical GKA External Leaks and Saves

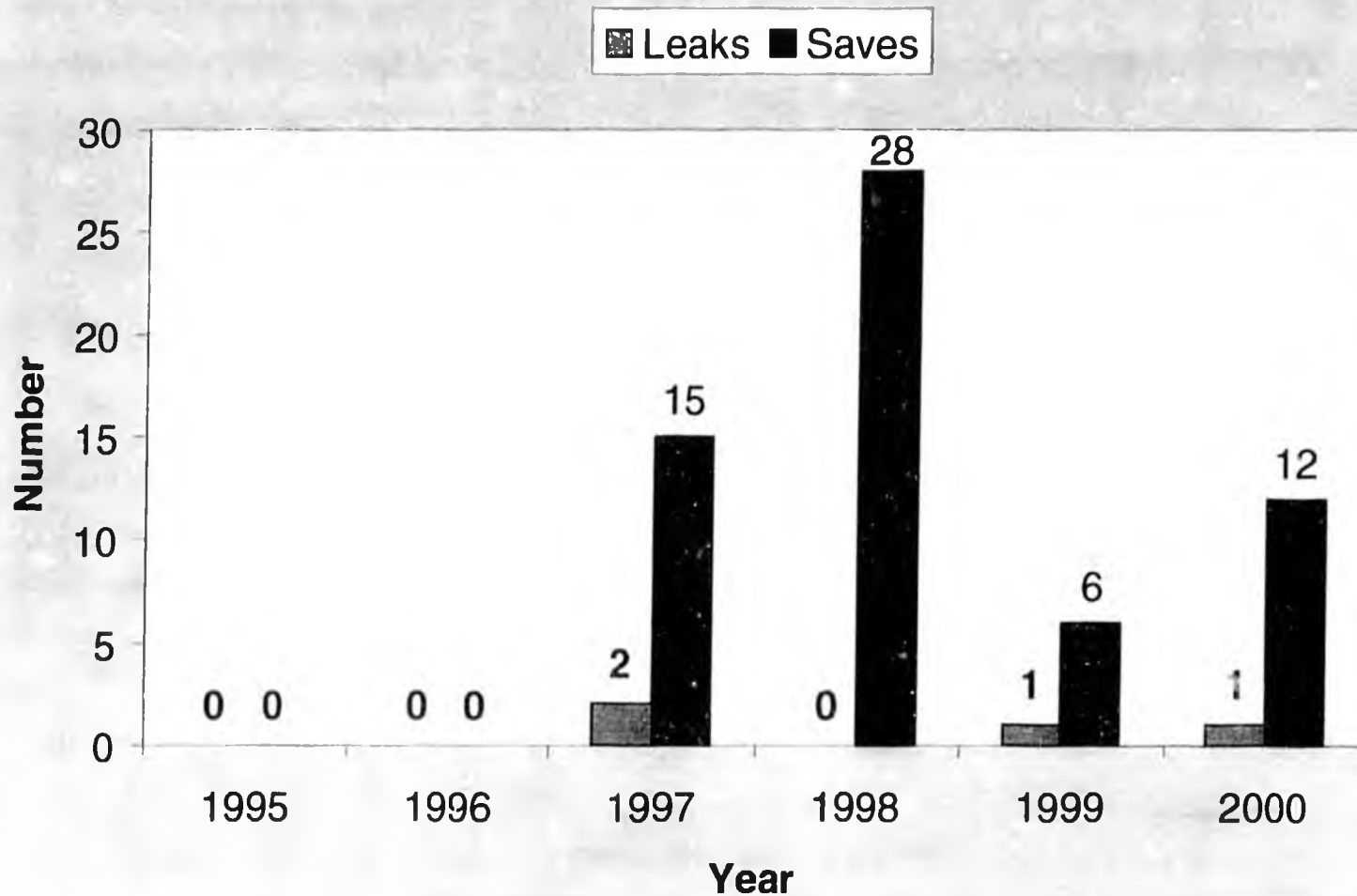



# Inspection - External Corrosion



WELL-2001 FORWELL

## ➤ **External (Weld-Pack) Program**

- ⇒ Complete inspection of remaining CC Off-Pad weld packs
- ⇒ Inspect 20% of CC On-Pad and well line weld packs.

## ➤ **Inhibitor Spikes For Weld Packs Pilot Program**

- ⇒ Test Inhibitor Spikes on 25 - 50 weld pack locations



# Inspection - Below-Grade Piping

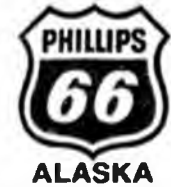

4R 2000

*ETIOWIN only*

Electromagnetic Inspection (PTI)				
Service	No. of Cased Pipe Segments	No EM (N)	EM (E)	Significant EM (S)
Gas (lift, Injection, Fuel)	6	5	1	0
Miscible Injection (MI)	3	3	0	0
Nat Gas Liquids (NGL)	0	0	0	0
Oil Sales (OS)	5	4	0	1
3 Phase Production (PC, PO)	12	10	2	0
2 Phase Oil & Water (WO)	0	0	0	0
Water Injection (PW, SW, Mixed)	31	26	5	0
<b>Totals</b>	<b>57</b>	<b>48</b>	<b>8</b>	<b>1</b>

*1598  
2/13/00*

Guided Wave Inspections (TWI)						
Service	No. of Cased Pipe Segments	Inconclusive Anomalies (I)	No Significant Indication (N)	Minor (Low) Anomalies (L)	Moderate Anomalies (M)	Severe Anomalies (S)
Gas (lift, Injection, fuel)	7	1	5	1	0	0
Miscible Injection (MI)	0	0	0	0	0	0
Nat Gas Liquids (NGL)	1	0	0	1	0	0
Oil Sales (OS)	1	0	1	0	0	0
3 Phase Production (PC, PO)	26	2	19	4	1	0
2 Phase Oil & Water (WO)	10	1	9	0	0	0
Water Injection (PW, SW, Mixed)	10	0	6	1	3	0
<b>Totals</b>	<b>55</b>	<b>4</b>	<b>40</b>	<b>7</b>	<b>4</b>	<b>0</b>



# Inspection - Below-Grade Piping



## ➤ 739 BGP Locations in Field

- ✓ 210 locations inspected using PTI/TWI

- ✓ 7 locations excavated - '98, '99, '01

  - ⇒ 1 location required repair

  - ⇒ All locations refurbished

- ✓ Based on TRT inspections at casing ends... '98, '99, '00

  - ⇒ 3 locations replaced without excavation

  - ⇒ 1 location refurbished

## ➤ 388 significant locations remain for inspection

  - ✂ 54 lines - plastic, new, replace

  - ✂ 87 lines - flare pit gas & drain lines  $\leq 2$ " diameter



# Inspection - Below-Grade Piping



2001 FUNDING

## ➤ **Below Grade Piping Program**

- ⇒ Inspect 100 road crossings using PTI/TWI (base plan)
- ⇒ Pursue significant acceleration of PTI/TWI inspection program
- ⇒ Excavate 4 road crossings (base plan)
  - Refine PTI/TWI data reduction and interpretation using visual inspections
- ⇒ Planning additional excavations to improve alignment of PTI/TWI results and with other risk factors
- ⇒ Reprioritization of BGPP based on data from expanded work scope described above.

# Structural Concerns

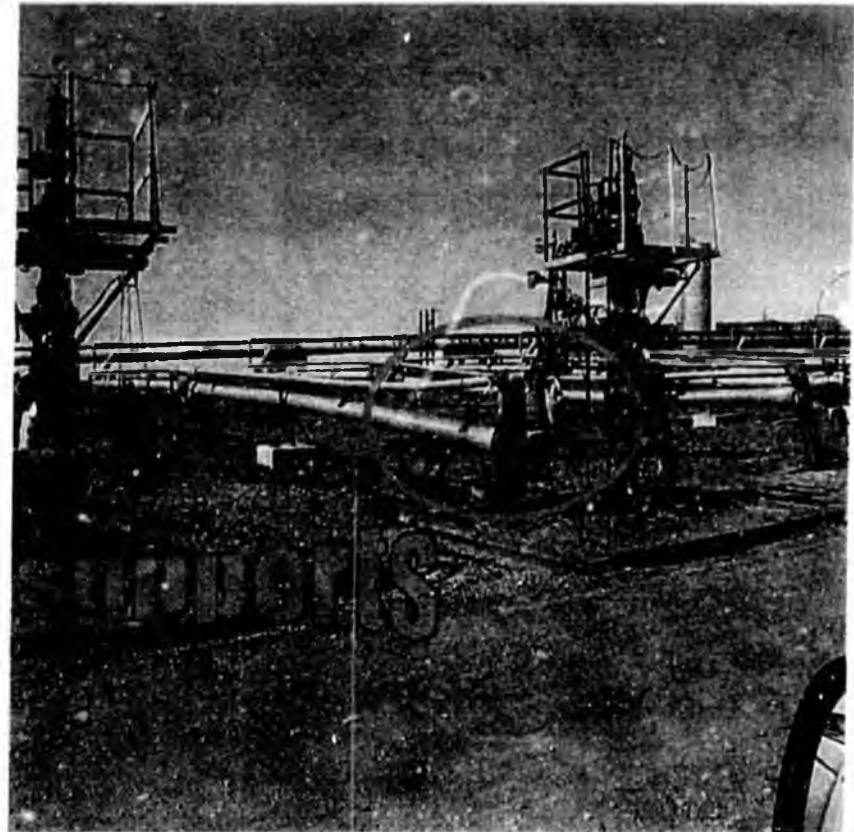
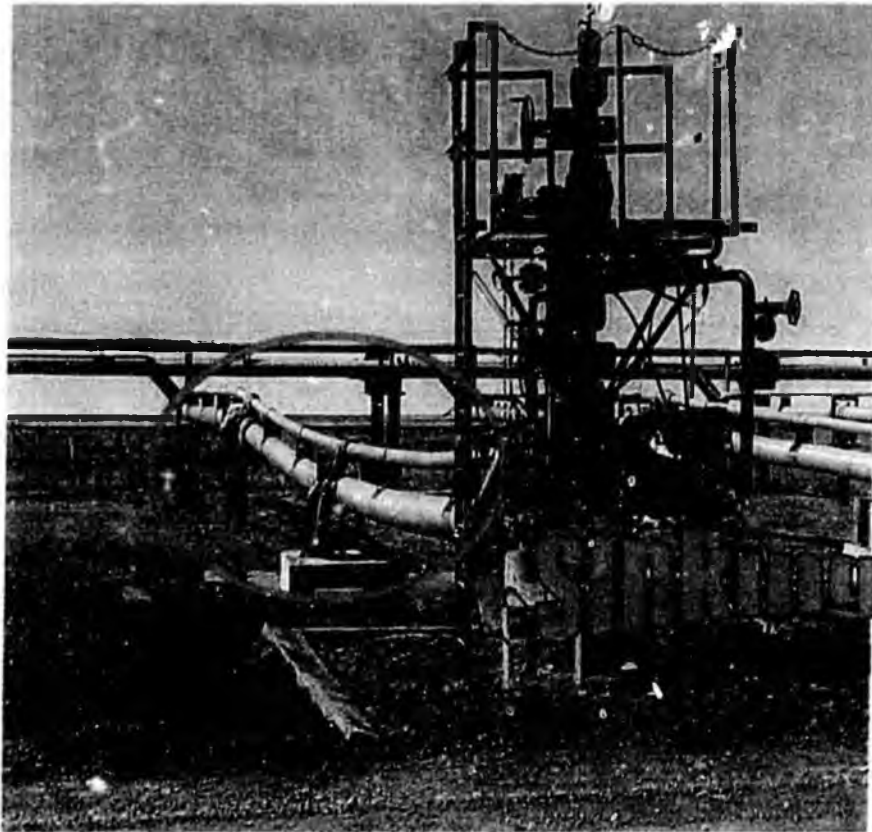

Real issue is **sinking supports** combined with snowloading.  
(Lines will bend until support is met. )

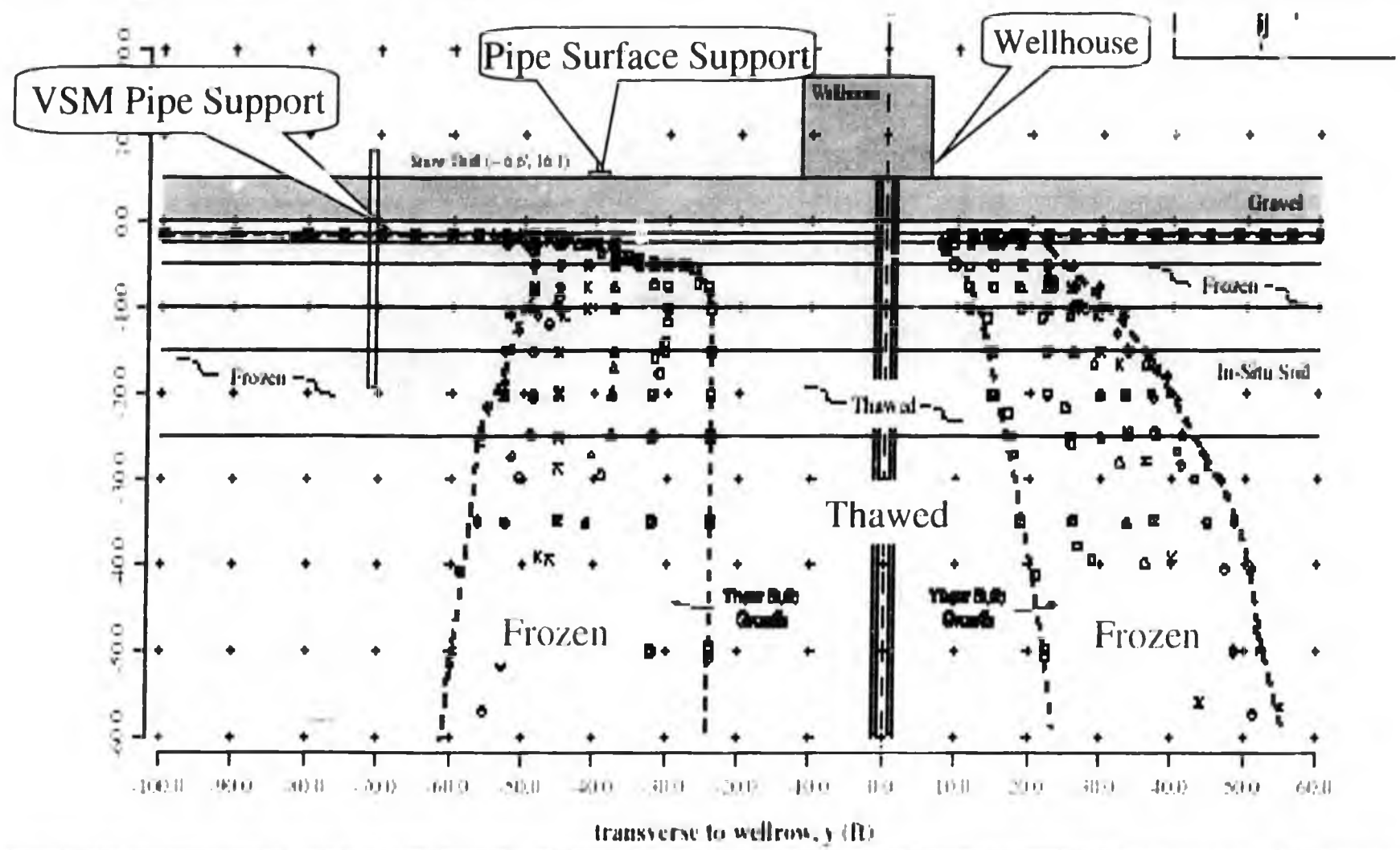

Predicted thaw bulb growth (worst case) over next 10 yrs.

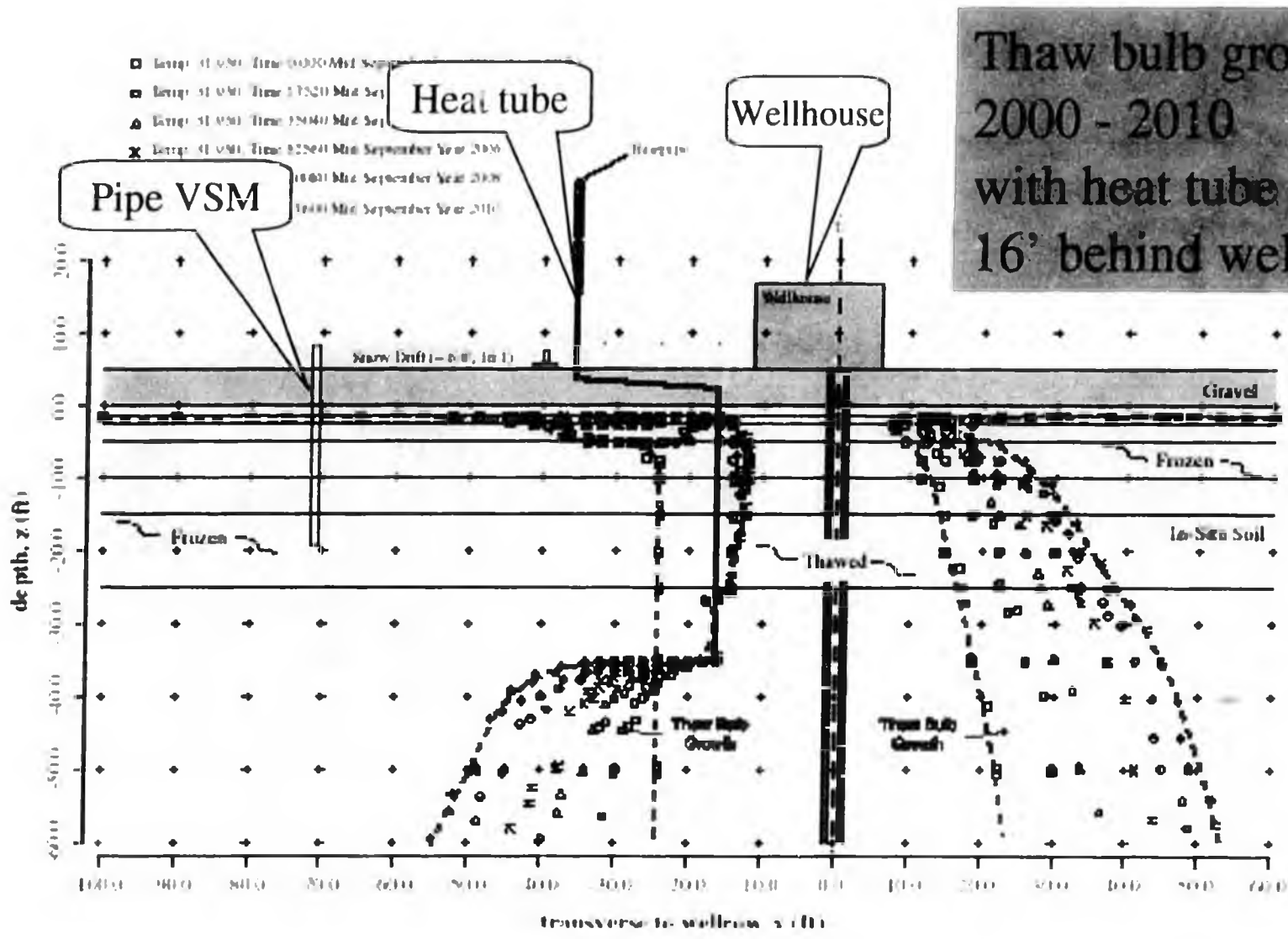

Thaw bulb growth  
2000 - 2010  
with heat tube located  
16' behind well



# Structural Concerns

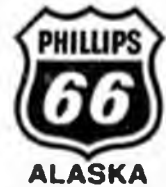

- Subsidence Mitigation at the Drill Sites
  - ⇒ Heat tubes being installed behind well houses
    - ⇒ Freeze back & pipe support
  - ⇒ Floors/Riser piping supports off of conductors
  - ⇒ All new wells and conversions to water injection
  - ⇒ Existing wells prioritize based on history
  - ⇒ \$1MM + spent on summer gravel work in 2000
  - ⇒ \$4MM total spent on mitigation 2000 - 2001

## Well Line Piping - Sagging Pipe

- ⇒ Preliminary studies suggest no immediate loss of strength
- ⇒ Ductility/strain hardening over time is primary concern (i.e. cracking)
- ⇒ Deformed lines are evaluated and corrective action applied on a case-by-case basis

## Year 2001 Forward

Decision and execute enhancements to the Kuparuk Corrosion Database.

Continue to evaluate, prioritize, and implement subsidence mitigation efforts at the drill sites.

Evaluate suitability of snow fences to minimize snow accumulation on well lines.

Continue with heightened level of snowload monitoring and snow removal.



# Spills/Incidents



- 2M-01 Well Line Riser Leak 5/6/00 200 gallons
  - ⇒ Fatigue-type failure @ wellhead riser
  - ⇒ caused by slugging, coupled with pipe support subsidence and snow loading
- 2X-16 Well Line Leak 7/3/00 10 gallons
  - ⇒ External corrosion damage was identified prior to leak - well was shut-in and displaced with diesel
  - ⇒ Began leaking after it was shut-in; leak found while additional inspection was being done
  - ⇒ Thermal expansion of the trapped diesel was the cause
- 1G-08 Well Line Leak 12/27/00 70 gallons
  - ⇒ Caused by internal corrosion
  - ⇒ Thin-walled (0.280") piping, producing well
  - ⇒ Was lower-tier priority on our inspection list



# Spills/Incidents



- **1B Injection Line Rupture      4/15/01      92M gallons**
  - ⇒ **Line ruptured, and low pressure alarm was received**
  - ⇒ **Leak detected and isolated within 12 minutes**
  - ⇒ **Rupture located in road crossing behind CFF1**
  - ⇒ **External corrosion @ weld pack in road crossing was cause**
  - ⇒ **Spill area on tundra, just less than 1 acre**
  - ⇒ **All accessible weld packs inspected**
  - ⇒ **2nd 1B-WI culvert location being excavated & inspected**



# Spills/Incidents



➤ 1B Injection Line Rupture      4/15/01      92M gallons

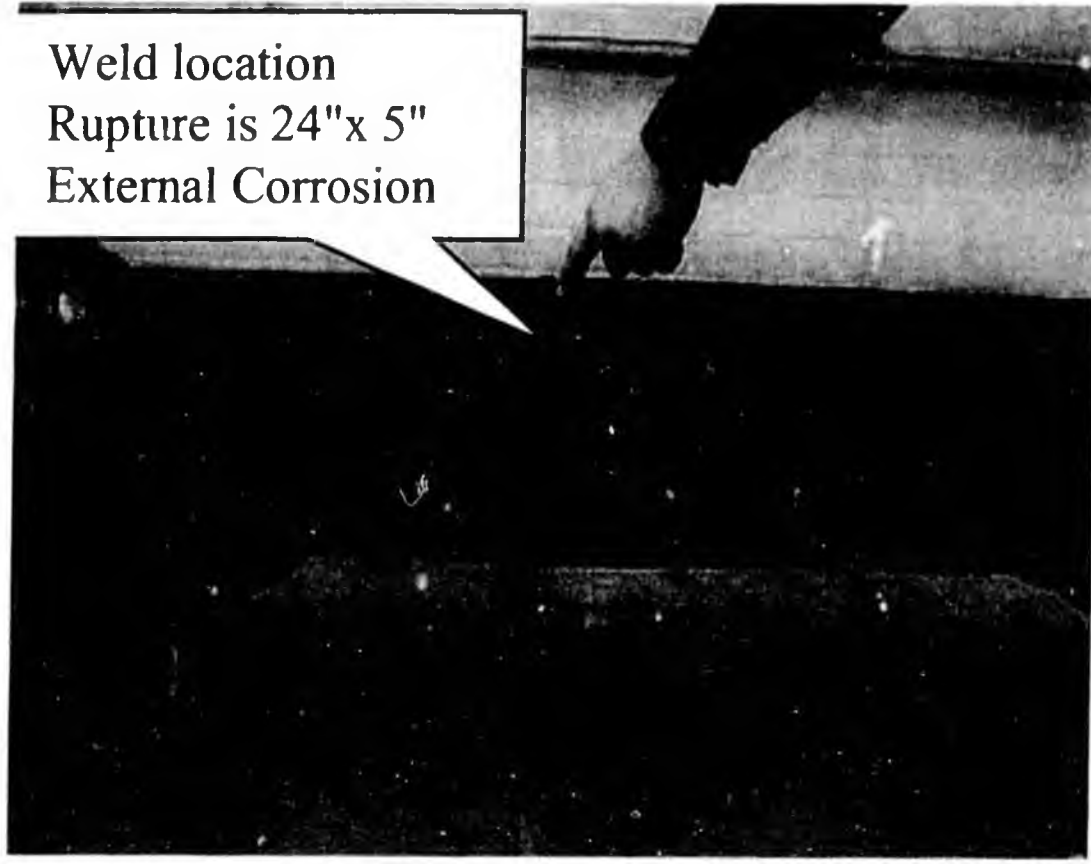

Weld location  
Rupture is 24"x 5"  
External Corrosion



# Spills/Incidents



➤ **1B Injection Line Rupture**      **4/15/01**      **92M gallons**

⇒ Reviewed Monitoring & Inspection History.....

- ✓ TRT'd in 1998 & 2000, 149 weld packs out of 157 total
  - All over-tundra and on-pad @ Drillsite weld packs TRT'd
  - No derating corrosion found
- ✓ Coupon data since 1982 indicated low internal corrosion risk
- ✓ Maintenance Pigging schedule on-target
- ✓ RTR'd in 1993 & 1997, 3000' total - no internal corrosion noted
- ✓ RTR 'd additional 243' on 4/23/01 - no internal corrosion noted
- ✓ Road crossing was scheduled for inspection late 2001



# Closing

---



## Topics for discussion

- \* Data reporting - What is meaningful to ADEC? What is not?
- \* BGP - Incorporate annual reporting into this NS Charter Agreement Report?
- \* BGP - Include all BGP inspection data, not just "oil" lines?

FALL 2001

BP

CPA



---

# Greater Kuparuk Area

## Corrosion Programs

### Overview

presented to the

Alaska Department of Environmental Conservation

*2nd Meet & Confer*

November 5, 2001

## Drivers

- > Internal Corrosion
  - ≈ Well Line Inspections
  - ≈ 1G-08 Production Well Line Spill
  - ≈ 24" Wet Oil Line Coupons
  - ≈ Corrosion Inhibitor Testing
- > External Corrosion
  - ≈ 10" 1HBWI Water Injection Common Line Spill

## Strategic Shifts

- > Inspection
  - ≈ Doubled Well Line Internal Inspection RTR Program Funding
  - ≈ Revised Internal Inspection Prioritization Scheme
  - ≈ Increased Well Line Inspection Efficiency
  - ≈ Tripled Below Grade Piping Program Funding
- > Monitoring/Mitigation
  - ≈ Decommissioned 24" Wet Oil Line
  - ≈ Fieldwide Deployment of New Corrosion Inhibitor (2000-25)
  - ≈ Implementing Wellhead Inhibition

*Handwritten notes:*  
10" 1HBWI  
24" Wet Oil Line  
PP1

## Internal Corrosion Monitoring Methods

### Electrical Resistance Probes

- target values < 1 mpy (mills per year)

### Coupons

Two types of evaluation used for coupons:

overall weight loss ≈ indication of fluid corrosivity

- target values < 3 mpy based on weight loss analysis

pitting depth ≈ indication of pitting corrosion, primary corrosion mechanism at Kuparuk

- target values < 10 mpy based on pit depth analysis



Cutaway of ER Probe

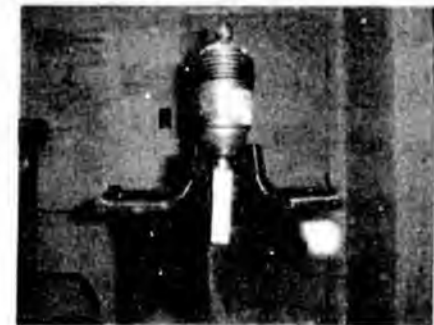

Cutaway of coupon in line

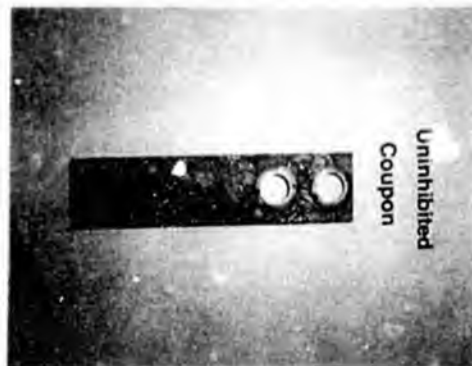

#### Weight Loss Analysis:

$$MPY = \frac{\text{Initial Weight} - \text{Final Weight}}{\text{Coupon Density} \times \text{Surface Area} \times \text{time exposed}}$$

#### Pit Depth Analysis:

$$MPY = \frac{\text{Pit Depth}}{\text{time exposed}}$$

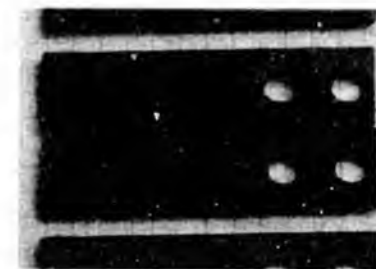

coupons



# Monitoring Results

## Crude Cross Country Lines



- Corrosion in Crude CC Lines is under control
- Average coupon and probe corrosion rates remain well under triggers
- Inspection data confirms corrosion is in check
- Probes - 95% of Line probes had corrosion rate <1.0 mpy
- Coupons - 6 Lines had corrosion rates exceeding trigger level
  - ✓ Inspected 4 of 6, three had at least 1 confirming increase location
  - ✓ Increased Corrosion Inhibitor rates on all 6 lines
  - ✓ Remaining 2 lines scheduled for inspection in 2002

*feel pretty good*

*50-60 lines total produced crude since 11 lines have 10-106 coupon locations*

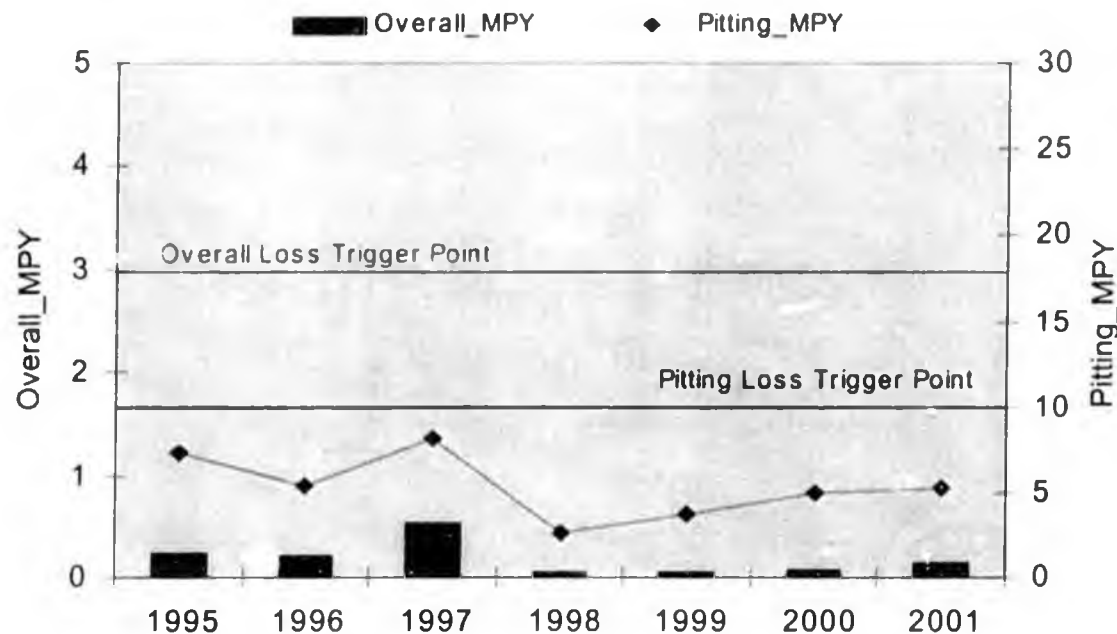

*Shows the manifold injector @ compressor is correct position*



# Monitoring Results

## Water Injection Cross Country Lines



- > Corrosion is under control in Water Injection CC Lines
- > Average coupon data has remained below triggers since 1998
- > Inspection data confirms that corrosion is in check
- > Coupons - 8 Lines had corrosion rates exceeding trigger level
  - ✓ Inspected 6 of 8; 5 were baseline and 1 recur with no increase
  - ✓ 4 of inspected lines showed less than 5% wall loss
  - ✓ 2 of inspected lines showed ~30% wall loss (worst case)
  - ✓ 5 of 8 lines had subsequent coupons below trigger level

*Water Chemistry  
1/12/01*

*operation of pipeline lines?*  
*CPE is still site*  
*coupon on injection line*  
*corrosion*  
*(How many lines?)*  
*percentage of the field*  
*inspected from 10*  
*sub-*

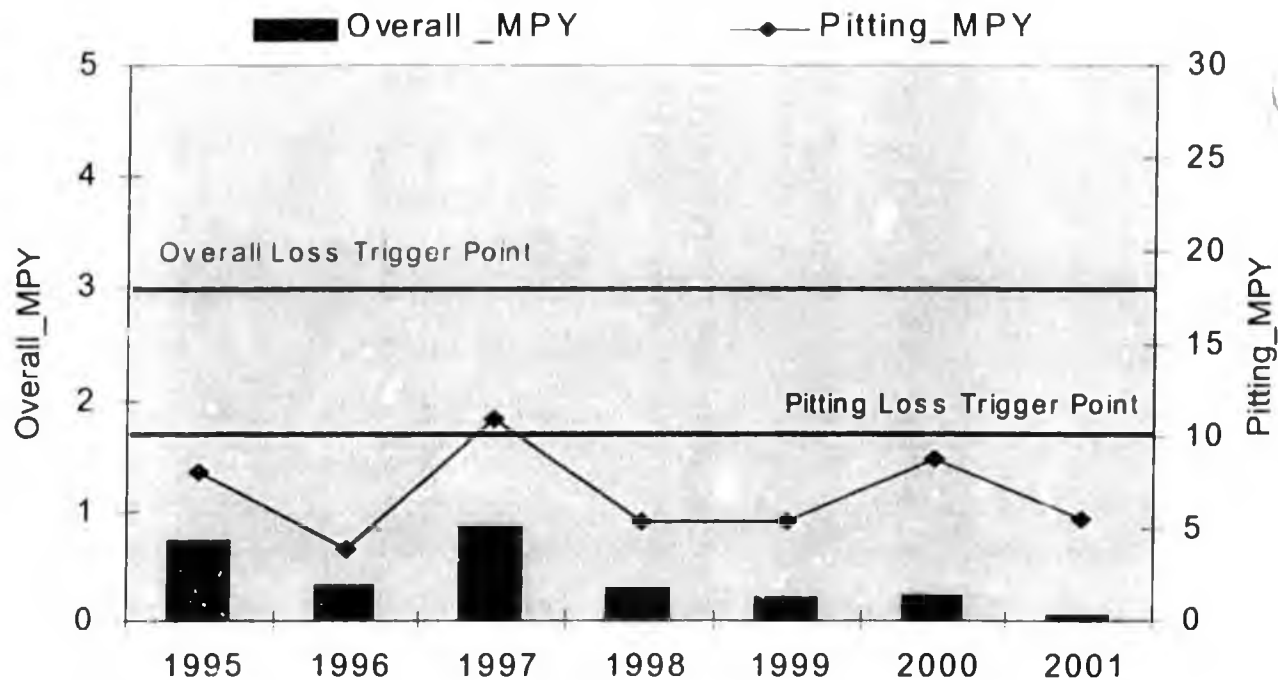

# Monitoring Results

## Wet Oil Cross Country Lines

- Corrosivity in wet oil lines a result of high water cut
- 24" Wet Oil Line was decommissioned in June 2001
- Coupons - 2 Lines had corrosion rates exceeding trigger level (includes abandoned 24")
  - ✓ Inspection on 12 " Line indicated no damage
  - ✓ Corrosion Inhibitor rates were increased and remain at high levels
  - ✓ Pigging frequency increased from 3 months to 2 months

*24" Wet Oil Line  
decommissioned  
June 2001  
off*

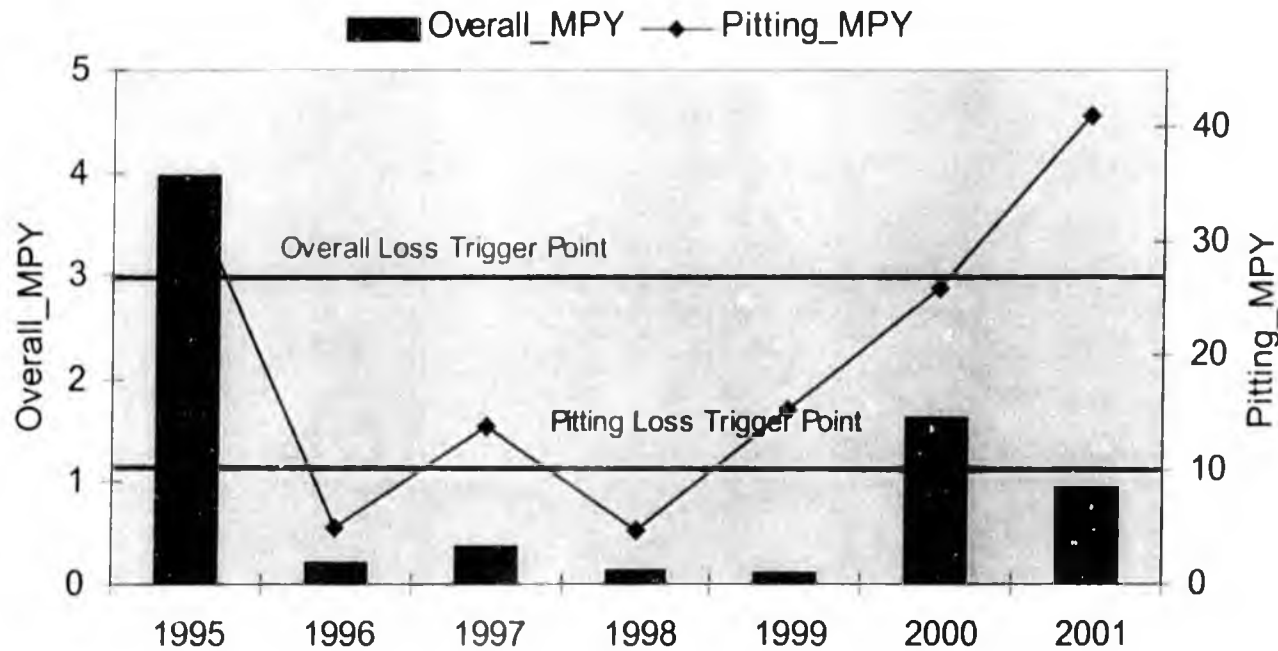



# Monitoring Results



## Production Well Lines

- Coupon Trends indicate corrosivity not increasing, but don't indicate full story
- Inspection data on older/thinner lines indicates significant corrosion damage
- Doubled inspection effort on well lines in 2001
- Coupons - 2% or 13 Lines had corrosion rates above trigger level
- All lines inspected in 2001
  - ✓ Maximum wall loss 25% for 1 line
  - ✓ 8 Lines showed less than 20% wall loss
  - ✓ 4 Lines showed no damage

*one monitor  
to monitor - needs*

*1/2 in. water,  
2000 ft,  
100 ft produced  
water*

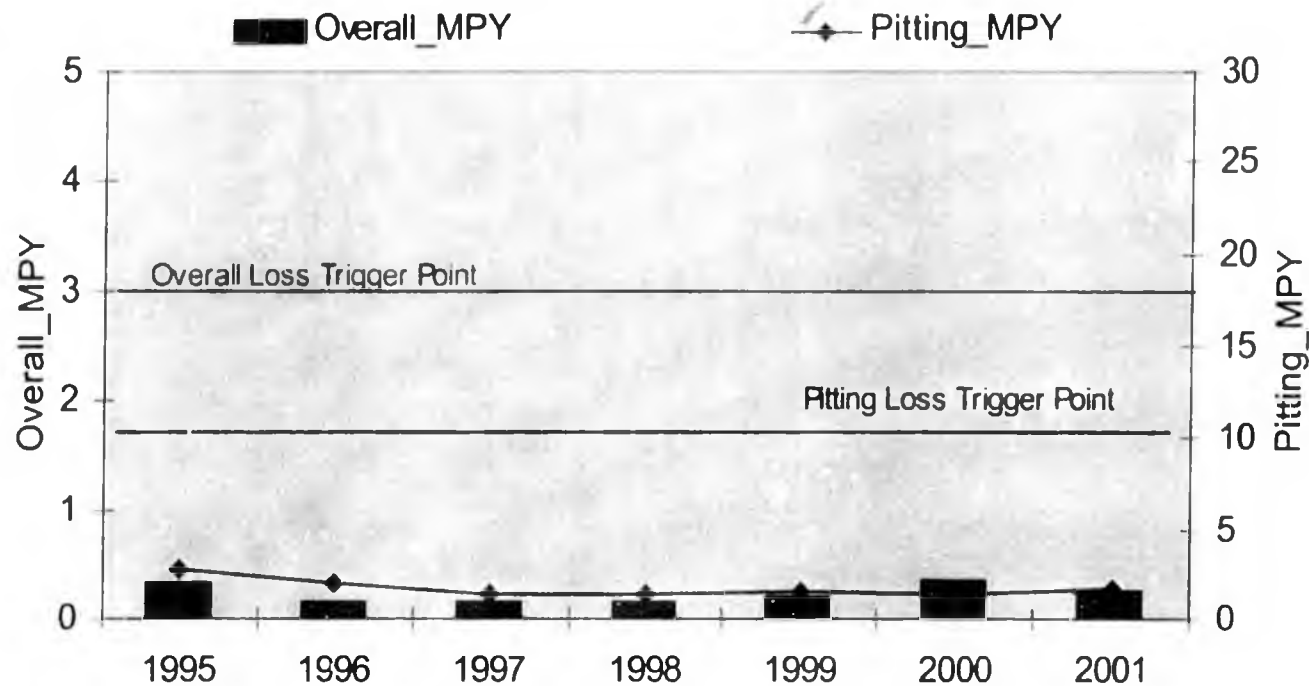

# Monitoring Results

## Water Injection Well Lines

- > Trends indicate corrosivity on the rise
- > Inspection data on older/thinner lines indicates significant corrosion damage
- > Coupons - 20% or 72 Lines had corrosion rates above trigger level
  - ✓ Coupon results factored into well line inspection prioritization
  - ✓ Doubled inspection effort on well lines in 2001

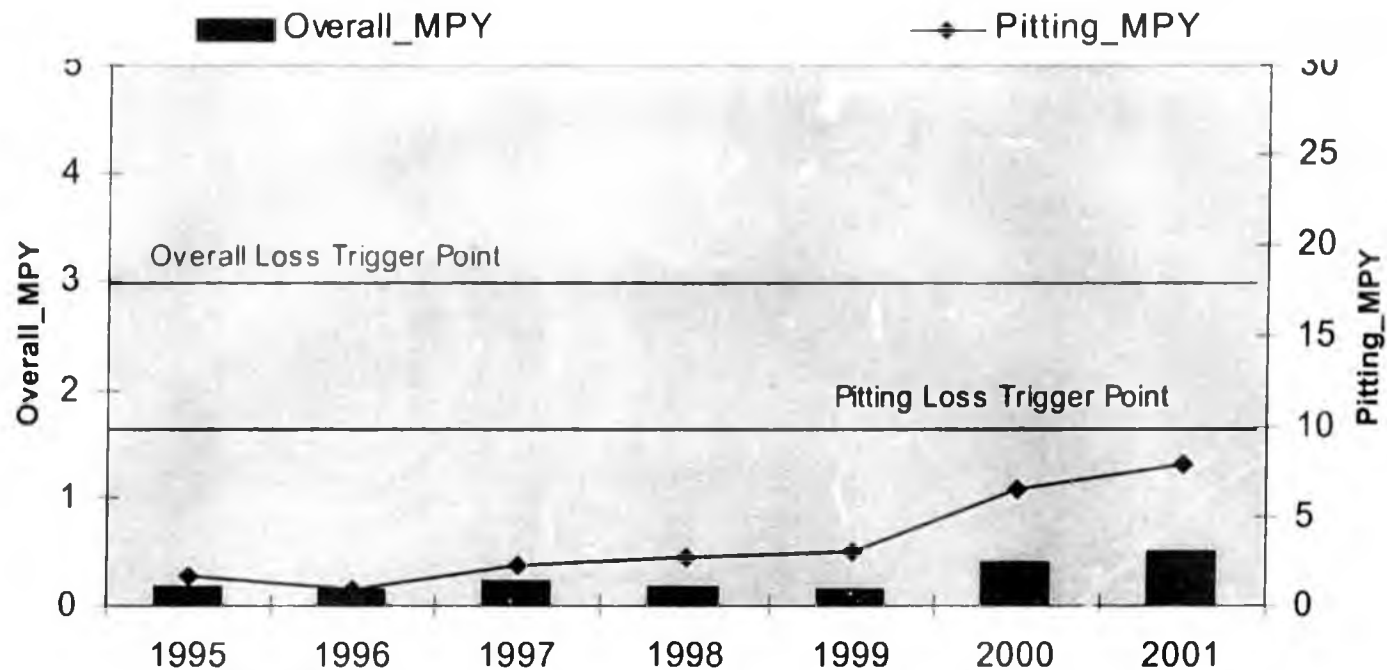

## Accomplishments

2001 YTD

- ✓ New inhibitor, Cortron 2000-25, implemented field-wide in April 2000  
- new formulation being field tested 3rd / 4th Qtr
- ✓ First stage of wellhead chemical inhibition facilities in final design,  
construct late 2001/early 2002 (Drill Site 1G)
- ✓ 24" Wet Oil Line decommissioned in June 2001
- ✓ Created Automated Maintenance Pig Tracking System to enhance  
correlation of pigging frequency with corrosion data
- ✓ Increased Maintenance Pigging Frequency on 12" Wet Oil Line
- ✓ Initiated (Schmoo-B-Gone) Chemical Treatment Test for Well Line  
Deposit Reduction on 3 Water Injection Wells/Well Lines



# Inspection Results

## Internal Corrosion



### Cross Country Lines ~234 Cross Country Lines at Kuparuk

- > Cross Country Line Inspection Program Successful
  - ✓ 0 lines required repair due to internal corrosion
  - ✓ Inspected 9,500 feet on 16 lines using automated radiography
  - ✓ 1,517 manual radiography inspections on 107 lines; 2 increases
  - ✓ 721 Ultrasonic inspections on 121 lines; 10 increases

*no any repair recommendation*

**Internal Corrosion Spills  
- Cross Country Lines**

1994 Spill 24" 1Y/R Crude CC Line

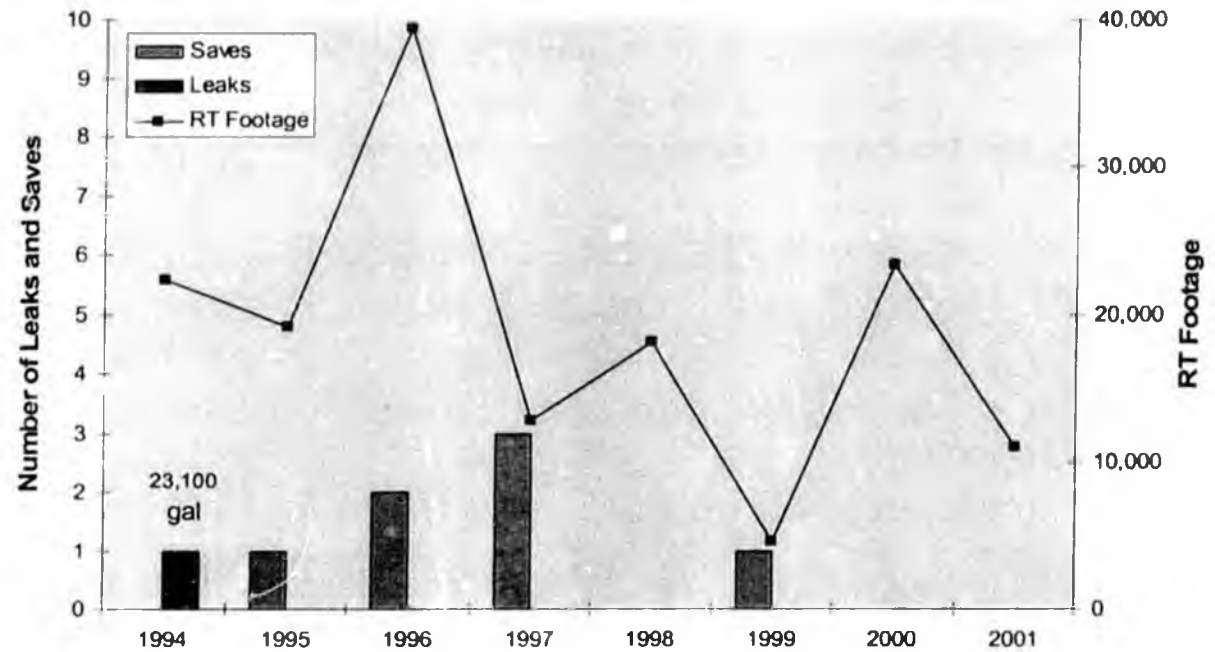



# Inspection Results

## Internal Corrosion

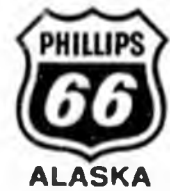

### Well Lines ~ 1000 well lines at Kuparuk

- Inspection Efficiency Increasing, Doubled Funding
- Older/Thinner Wall Well Lines are corroding
  - ✓ Inspected 41,600 feet on 265 well lines using automated radiography
  - ✓ 2,530 manual radiography inspections on 292 well lines; 15 increases
  - ✓ 2,012 ultrasonic inspections on 310 well lines; 77 increases
  - ✓ 18 well lines required repair (11 injectors, 7 producers)

#### Internal Corrosion Spills -Well Lines

1998 Spills	1L-1 6" WI Line
	1L-3 6" WI Line
	1A-9 6" WI Line
2000 Spill	1G-8 6" PC Line

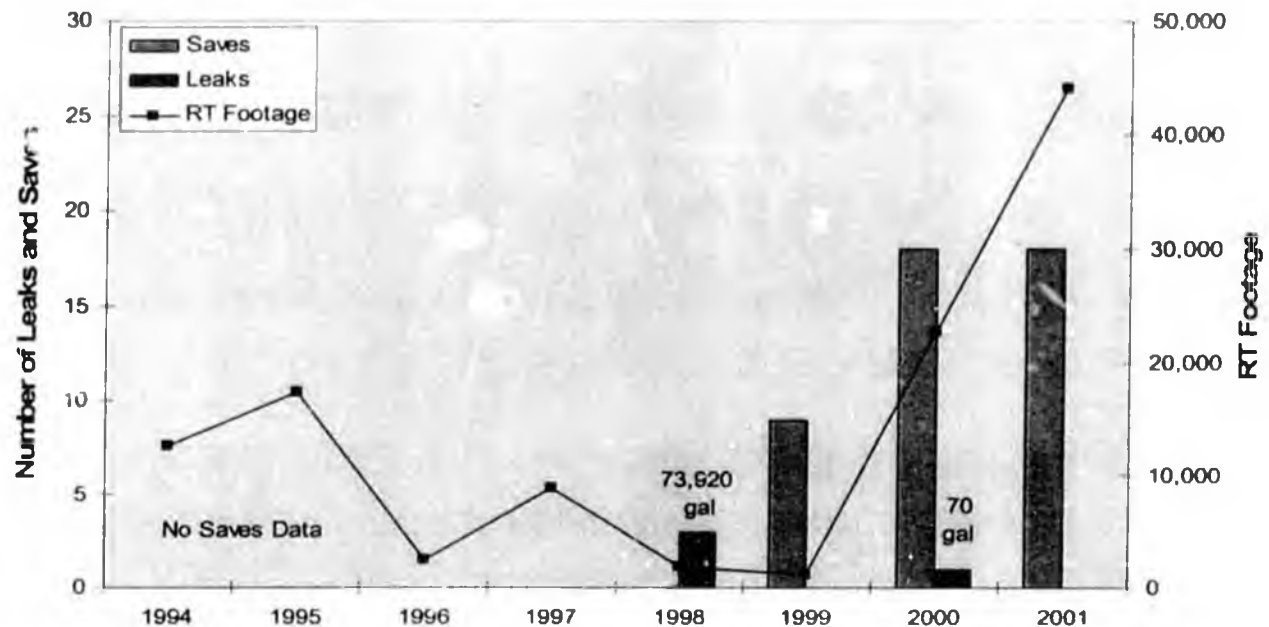



# Inspection - Internal Corrosion



## Accomplishments

*2001 YTD*

- ✓ Accelerated Real Time Radiography well line program
  - Doubled funding, increased inspection efficiency for well lines
  - Focus on older, thinner-walled well lines
    - ➔ 0.280" Wt Lines, 100% inspected YE 2001
    - ➔ 0.312" Wt, 50%+ inspected YE 2001, 100% YE 2002
- ✓ Initiated "wandering can" inspection to confirm prioritization and check for anomalies
- ✓ Finalizing Data Base Implementation for risk-ranked Cross Country Line Elbow Program



# Inspection Results

## External Corrosion



### > Common Lines, Off-Pad

- ✓ Off-pad weld pack inspection 99.9% complete (out of ~67,000 total)
- ✓ 2 repair locations in 2001
- ✓ Complete inspection of off-pad weld packs by end of 2001

### > Common Lines, On-Pad

- ✓ On-pad weld pack inspection 50% complete (out of ~8,900 total)
- ✓ 0 repair locations in 2001
- ✓ Complete inspection of on-pad weld packs by end of 2004

### > Well Lines

- ✓ Weld pack inspection ~41% complete (out of ~24,000 total)
- ✓ 2 repair locations in 2001
- ✓ Complete inspection of well line weld packs by end of 2005

*Well Line weld pack inspection efficiency increasing*

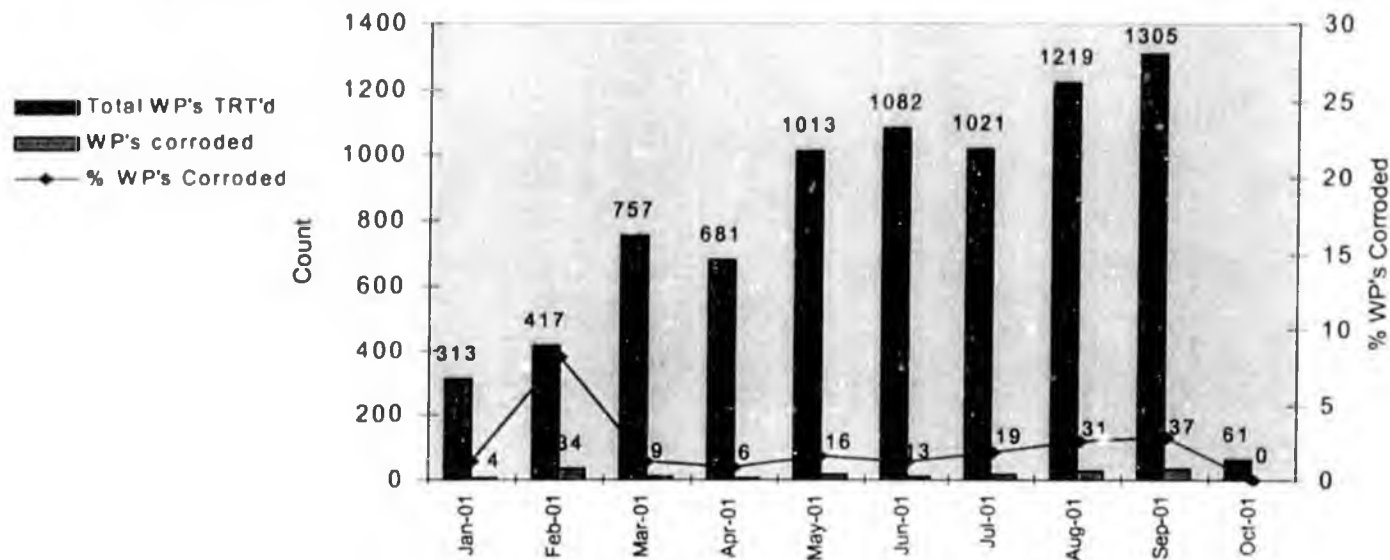



# Inspection - External Corrosion



## External Corrosion Line Failure History

1995	2C-04 Well Line
1997	2 ea. 24" Crude CC Lines (Weld Pack @ Saddle)
1999	1A-15 Well Line (Weld Pack @Saddle)
2000	2X-16 Well Line
2001	10" CC PWI Line (Weld Pack in Road Crossing)

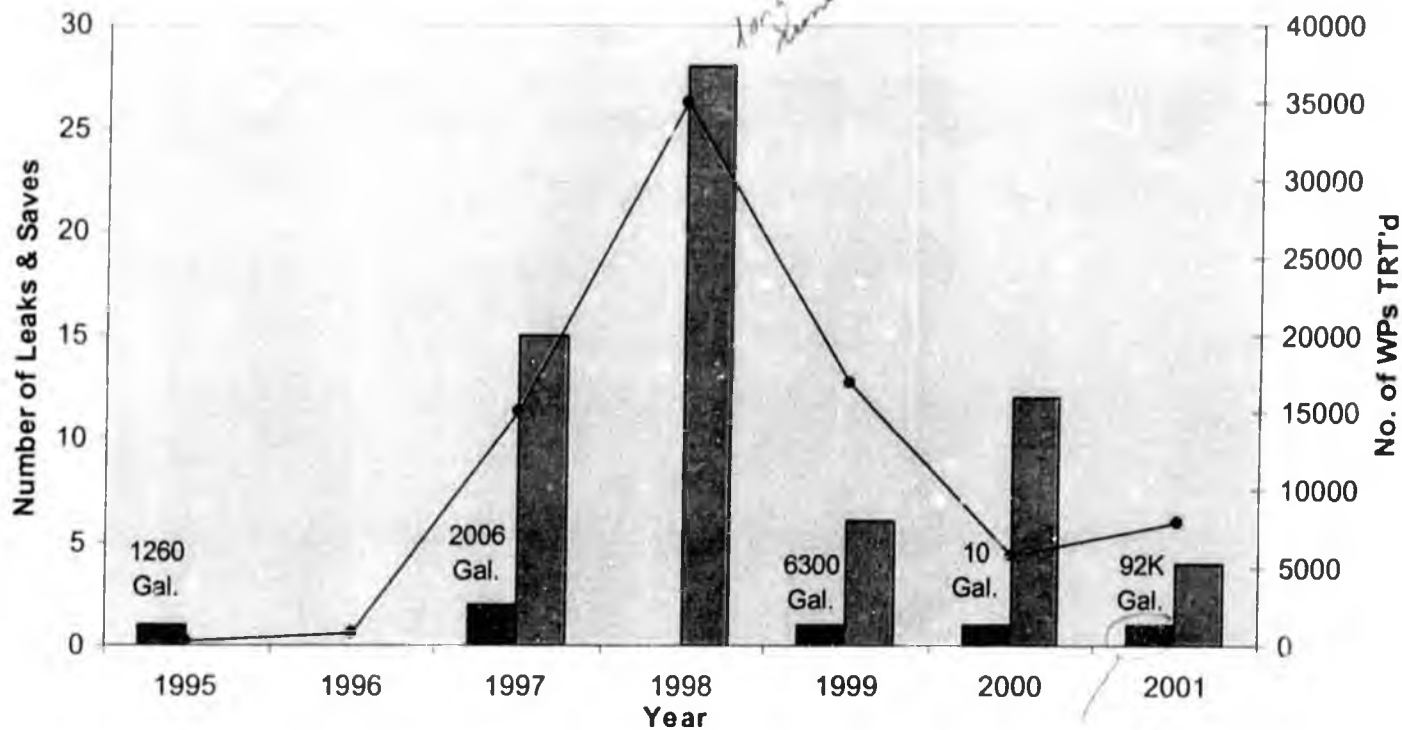



# Inspection - External Corrosion



## Accomplishments

2001 YTD

- External (Weld-Pack) Program
  - ✓ Complete inspection of remaining CCL Off-Pad weld packs by YE 2001
    - Inspection of all Off-Pad CCLines currently 99.9% complete
  - ✓ Concentrating on inspection of CCL On-Pad and well line weld packs
  - ✓ Increasing inspection efficiency of well line weld pack program
  - ✓ Buffer Spikes Pilot Program For Weld Packs Begun



# Inspection Results

## Below-Grade Piping



### > 2001 Program

- ✓ Inspected 220 new locations using PTI/TWI technologies
  - (273 total locations including recurs)
- ✓ Had 2 TWI "Severe" indications
  - 1 was excavated - only minor damage found
  - 1 is shut-in pending inspection/testing plan
- ✓ Completed 9 excavations, YTD *Based on last year results*
  - 2 locations required repair
- ✓ Completed annual visual inspection of all 732 cased road crossings (ensures free flow of ground water)
  - Found 52 partially obstructed, all have been cleared



# Inspection - Below-Grade Piping



## Accomplishments

- (1) ✓ Tripled Funding of Below Grade Piping Program
- ✓ Doubled PTI/TWI effort from ~100 to 220 new locations
- ✓ Expanded excavations from base plan of 4 to 9 YTD
- ✓ Completed annual visual inspection of all locations
- ✓ Completed field test of new technology - GUL (Wavemaker)
  - Results being evaluated
- ✓ 2001 data being used to adjust 2002 work plan
- ✓ 152 Significant Road Crossing Remain for Inspection
  - ↳ All to be Inspected by YE 2002
- ✓ Continuing efforts with Phillips R&D, BP, and vendors to refine latest technologies and establish more precise correlation between signal and corrosion damage

2001 YTD  
2001 YTD  
(quantitative)  
or  
results



# Structural Concerns

## Primary Structural Concern Areas

- Piping deformation
  - Primary Causes
    - Subsidence
    - Frost Jacking
    - Snow Loading
- Wind Induced Vibration
  - Not currently an issue
    - Design/Use of weight dampeners

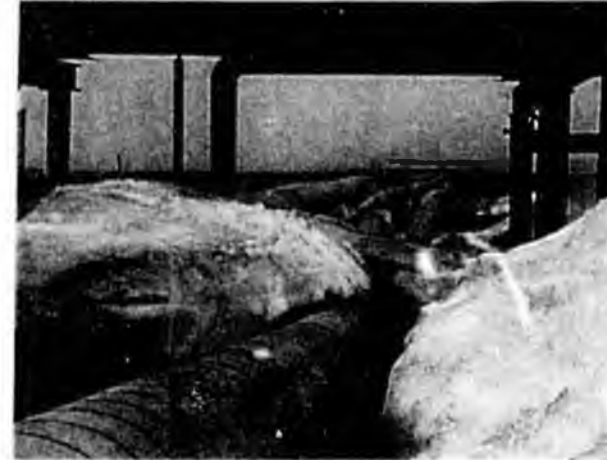

Photo copyright of Phillips Alaska, Inc. For Agency use only, not for publication without the explicit written permission of Phillips.



- Evaluate, prioritize, and continue implementation of subsidence mitigation efforts at the drill sites
- Pipe Deformation Analysis - Ongoing
- Continue with heightened level of snowload monitoring and snow removal



# Structural Concerns

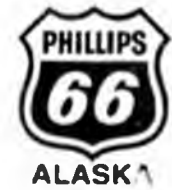

## Accomplishments

2001 YTD

### Subsidence Mitigation at the Drill Sites

- ✓ Well Design Guideline Approved March 2001
  - new wells, well conversions (producer to injector)
  - existing wells, based on prioritization/need
- ✓ 2001 funding = \$4MM+ *11/20*

### Pipe Sagging/Jacking *P 11/20*

- ✓ Annual Summer Gravel Work (\$500M)
- ✓ New Pipe Supports Being Installed
- ✓ VSM Leveling

# Spills/Incidents

10" 1B Injection Line Leak

4/15/01

## Scenario:

- Line Ruptured, pump shutdown alarm received
- Leak detected and isolated within 12 minutes
- Rupture located in road crossing just behind CPF1
- Spill area on tundra, just less than 1 acre
- Emergency Action Plan activated
- 92,000 gallons Produced Water

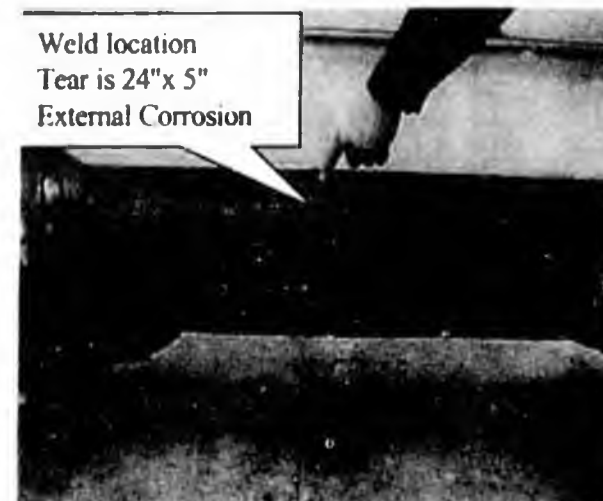

Photo copyright of Phillips Alaska, Inc. For Agency use only, not for publication without the explicit written permission of Phillips.

## Findings:

- Caused by external corrosion at a below-grade weld-pack
- Location of leak (very close to the plant) resulted in high flow rate
- Had not yet been inspected for Below-Grade Corrosion
- Location subject to snow melt/water runoff
- One of oldest waterflood cross country injection lines
- Original Kuparuk piping design not cognizant of weld pack corrosion potential



# Spills/Incidents



10" 1B Injection Line Leak

4/15/01

- Inspection & Monitoring History
  - ✓ 149 weld packs out of 157 total had been inspected
    - ↳ No derating corrosion found
  - ✓ Coupon data indicated low internal corrosion risk
  - ✓ RTR'd in 1993, 1997, & 2001
    - ↳ No internal corrosion noted
  - ➔ Scheduled for Below-Grade Inspection in late 2001
  
- Post-Spill Inspections
  - ✓ 2nd 1B-WI culvert location excavated & inspected
    - Inspection completed prior to re-start of line
    - same risk ranking as failed location
    - ➔ no significant damage
  - ✓ All remaining weld packs inspected
    - ↳ no derating corrosion
  - ✓ 1 remaining culvert location inspected w/ PTI/TWI
    - ↳ no anomalies

# Spills/Incidents

10" 1B Injection Line Leak

4/15/01

## ALL ITEMS COMPLETE

### ➤ Incident Corrective Actions

- ⇒ **Replaced failed piping** with a design suitable for road crossing environment (coated with new weld pack design)
- ⇒ Evaluate BGPP schedule and adjust priorities & pace based on lessons learned
- ⇒ Install low discharge pressure shutdowns on the water injections pumps @ CPF1, 2, and 3 (more rapid and reliable shut-off in the event of a future leak)

# Spills/Incidents

10" 1B Injection Line Leak

4/15/01

## **Lessons Learned:**

- Reviewed BGPP program in detail
  - External damage @ weld packs highly random
  - Prioritization factors provide limited benefit
  - Had 4-5 more years to complete baseline inspection survey @ present level of effort (100/year)
  - Acceleration of program most leveraging way to reduce future risk



# Spills/Incidents

10" 1B Injection Line Leak

4/15/01



## ➤ Corrosion Program Corrective Action Taken

### ✓ Accelerated BGPP to 2-year program

- Doubled # of target inspections, both non-intrusive & line excavations
- Level of effort constrained by resources (not \$)

### ✓ Reviewed all other elements of Corrosion Program to determine if adjustments were warranted

- Doubled Well Line Internal Inspection (RTR) effort to complete inspection of thin-walled lines

### ✓ \$1.2 MM Incremental Funding



# Closing

---



Topics for discussion ??

SPRING 2002

BP



**BP and State of Alaska Charter Agreement**  
**Corrosion Monitoring Review 2001**  
**Meet and Confer III**

**April 29<sup>th</sup>, 2002**

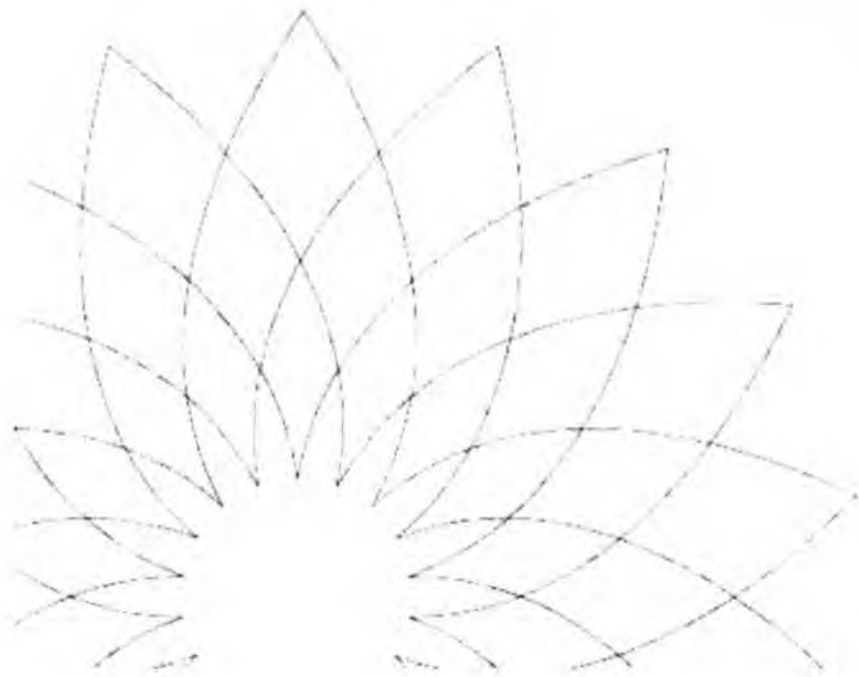



## Outline

- ▶ **Strategic Objectives**
- ▶ **Corrosion Management Process**
  - ▶ Program Elements
- ▶ **Fitness-for-Service**
- ▶ **System Review**
  - ▶ 3-Phase (OWG)
  - ▶ Produced Water (PW)
  - ▶ Seawater (SW)
  - ▶ Weight Loss Coupons (WLC)
  - ▶ Internal/External Inspections
- ▶ **Program Performance**
  - ▶ Leaks
  - ▶ Repairs
  - ▶ Action Plan
- ▶ **2002 Overview**
- ▶ **Summary**



# Corrosion Management Program

## ▶ **Strategic Objectives**

- ▶▶ Minimize health, safety, and environmental impacts
  - Loss of containment due to corrosion
  
- ▶▶ Fit-for-service infrastructure
  - Remainder of the life of the oilfield
  - Potentially 50+ years
  
- ▶▶ Infrastructure with sufficient mechanical integrity
  - Needed to produce satellite fields and accumulations
  - Use of existing infrastructure
  
- ▶▶ Support of future major gas development
  - Production and through current facilities
  - Gas sales demands longevity of infrastructure



# Corrosion Management Process

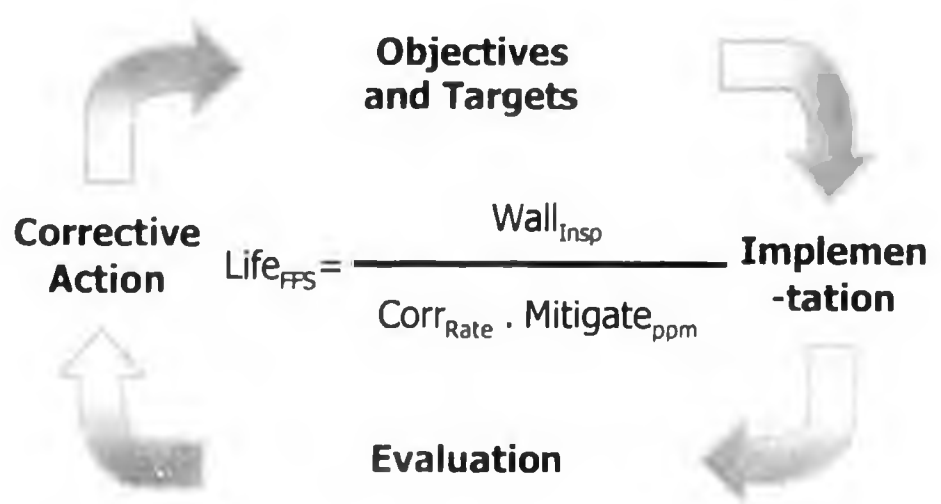

**Corrosion Management Process**

Step	Program Elements
Plan	<b>Objective</b> Program objective and purpose <b>Target</b> Performance metric
Do	<b>Implementation</b> Plan to achieve objective
Check	<b>Evaluation</b> Method to evaluate performance
Act	<b>Corrective Action</b> Correct deviation from target



# Fitness-for-Service Assessment

**ANSI B31G MAOP Curve**  
**24 OD x .375 WT X52 8.9 in. Corrosion Network**

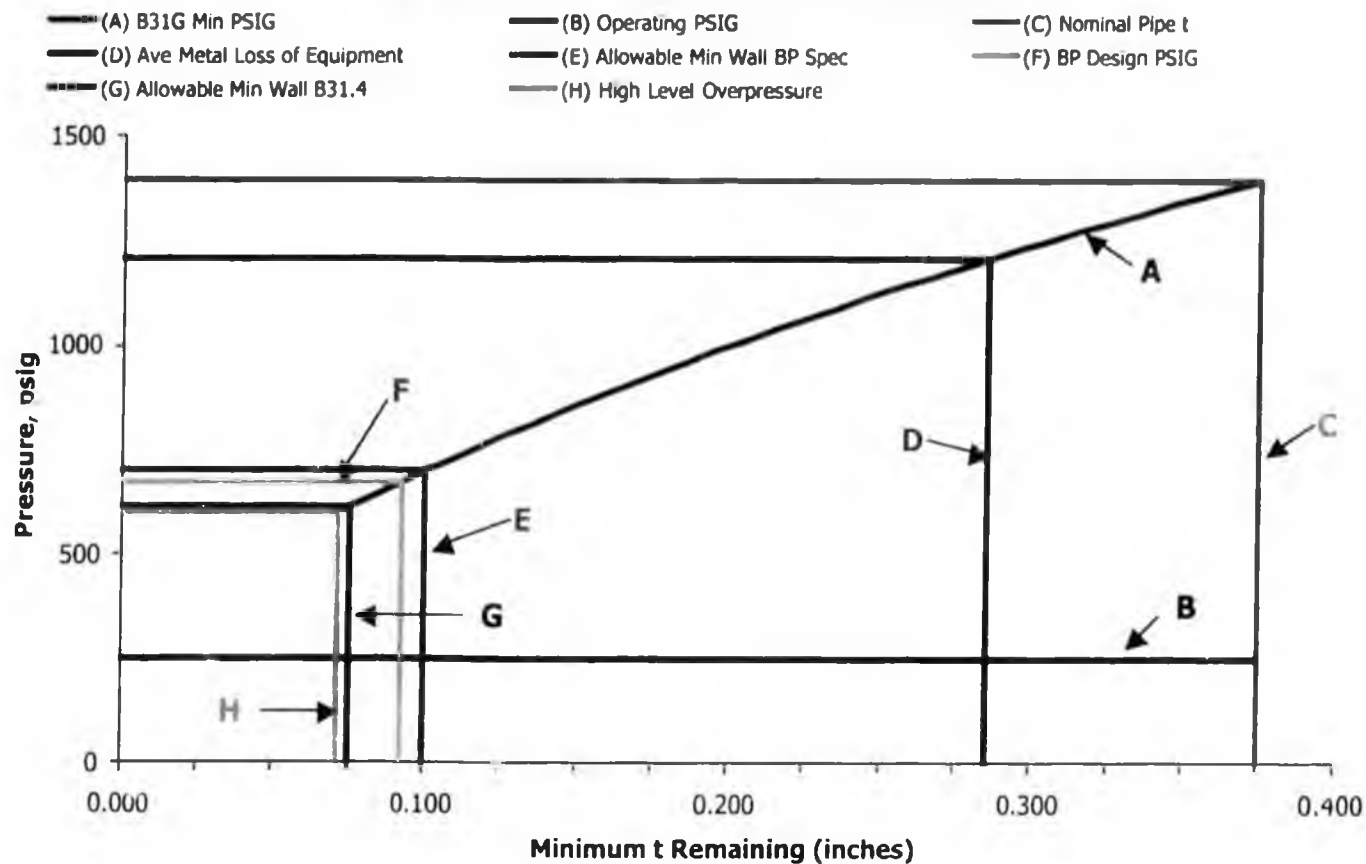



## Fitness-for-Service Summary

<u>Date</u>	<u>Thick(t)</u> (inches)	<u>MAOP</u> (psig)	<u>Notes/Comments</u>
<b>Install (1977)</b>	<b>0.375</b>	<b>1400</b>	<b>First oil 1977</b>
▶ <b>Today (2002)</b>	<b>0.285</b>	<b>1200</b>	<b>Ave CR 4 mpy to date</b>
<b>EOFL (2050)</b>	<b>0.100</b>	<b>700</b>	<b>At historical Ave CR</b> <b>- 1<sup>st</sup> 25 years CR 4 mpy</b> <b>- Target CR 2 mpy</b> <b>- 1/2 the historical ave</b>
<b>BP Spec</b>	<b>0.100</b>	<b>700</b>	
<b>FFS(B31G)</b>	<b>0.095</b>	<b>614</b>	<b>80% of original wall</b>
<b>Overpressure</b>		<b>600</b>	<b>System relief setting</b>
<b>Operating P</b>		<b>250</b>	<b>Normal operations</b>



# Overall – Increasing Corrosion Control

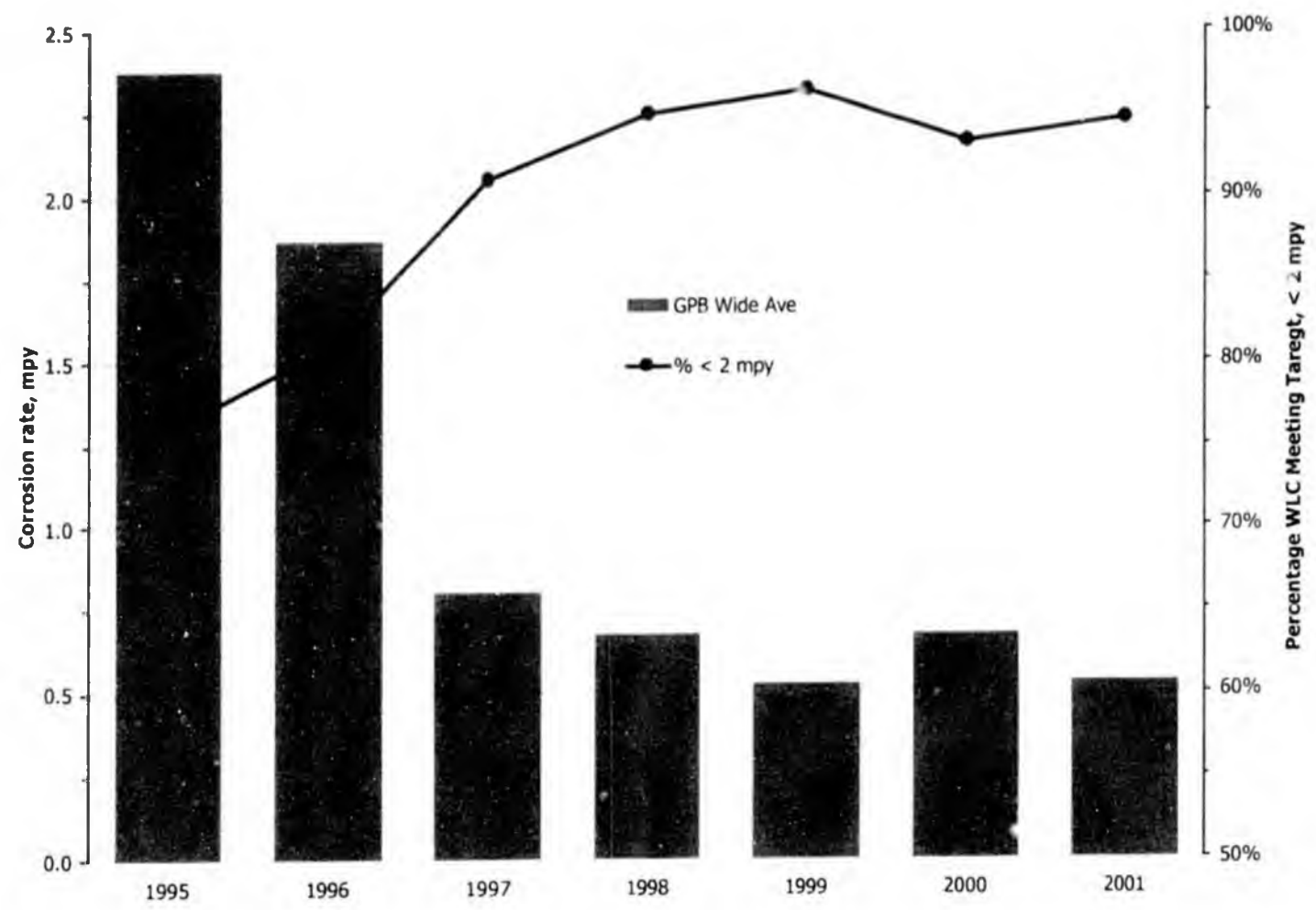

April 2002

BP/ADEC Meet and Confer III



# Overall Activity Level

## Corrosion and Inspection Activity Summary

			1995	1996	1997	1998	1999	2000	2001
Coupons	WL		6779	8183	8326	7837	7361	7322	5674
	FL		1569	1685	1729	1601	1650	1542	1426
ER Probes	FL							84	83
Inspection	Internal	WL	5919	8379	8174	7508	6224	7025	9780
		FL	21796	20680	21522	17995	14809	9602	11369
	External	WL	-	36	1682	946	2114	5283	12730
		FL	1508	11474	18009	10316	8139	5184	2675
Inhibition	CI	10 <sup>6</sup> gpy	1.62	2.05	2.21	2.53	2.28	2.73	2.63
		ppm	85	106	115	141	130	148	157

▶ **Substantially unchanged from prior years**

- ▶▶ Chemical injection volumes/ppm
- ▶▶ ER probe activity level



## **System-by-System Review**

- ▶ **Elements of Long Term Fitness For Service**
  - ▶▶ Corrosion monitoring
  - ▶▶ Inspection
    - Condition
    - Increases
  - ▶▶ Mitigation/corrosion control
- ▶ **Weight Loss Coupons**
  - ▶▶ Flow Line
  - ▶▶ Well Line
- ▶ **Inspection Increases**
  - ▶▶ Correlation between inspection increases and WLC
- ▶ **Equipment Condition**
  - ▶▶ Increases and condition correlation
- ▶ **Mitigation**
  - ▶▶ Correlation between corrosion rate and CI concentration



# 3-Phase (OWG) – FL Coupons

## Flow Line WLC Corrosion Rates

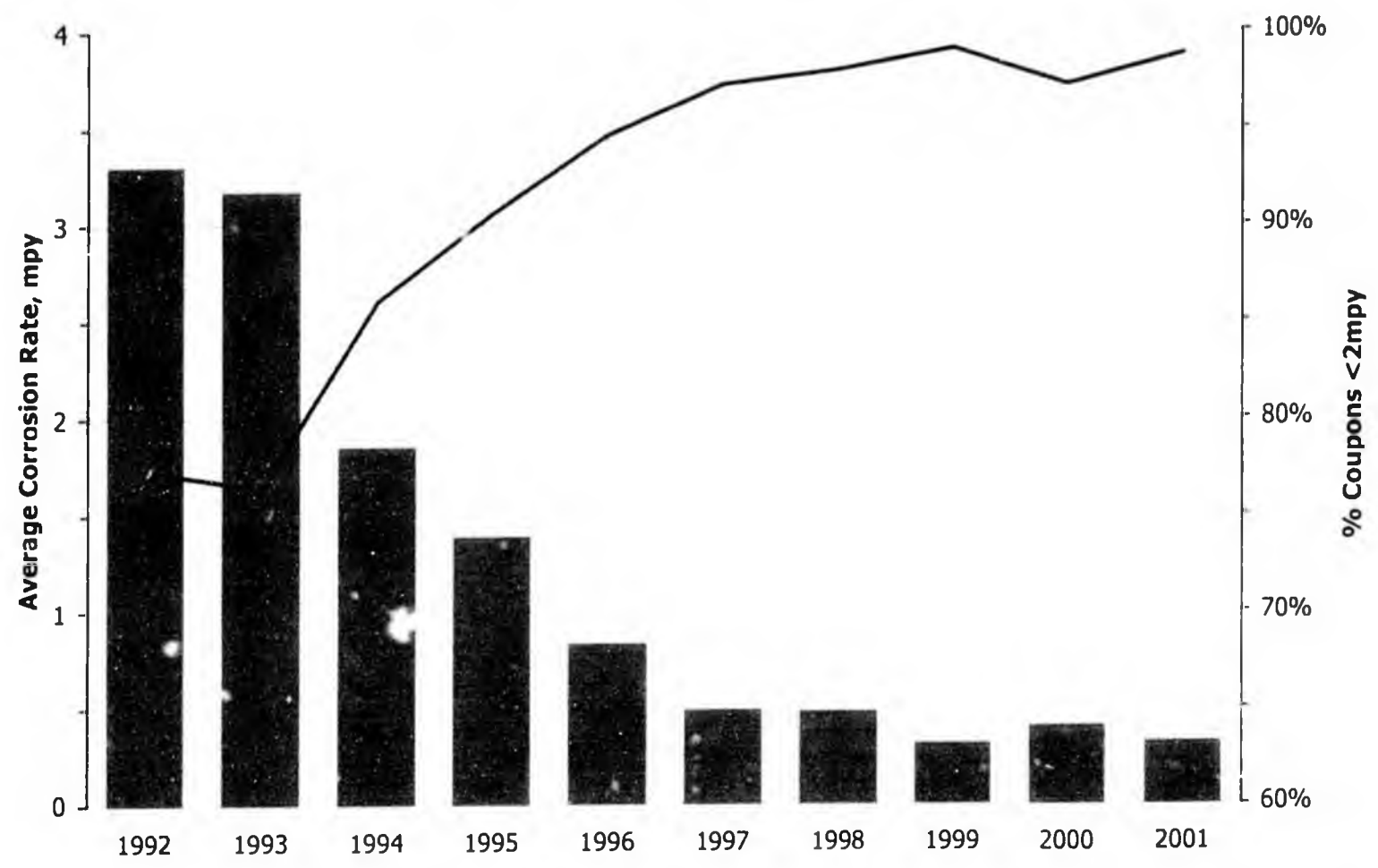



# 3-Phase (OWG) – WL Coupons

Well Line WLC Corrosion Rates

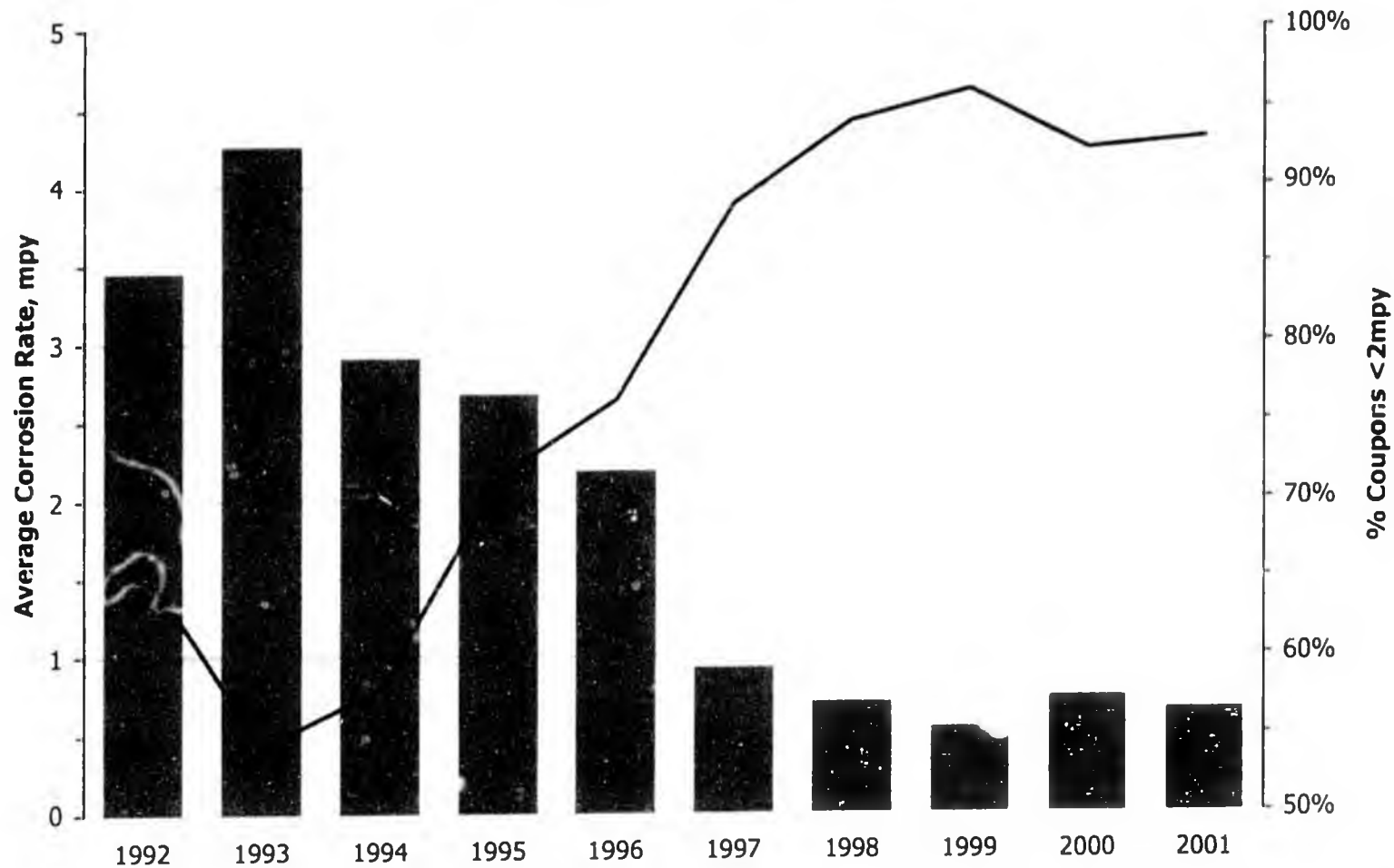



# Flow Line Inspection Increases

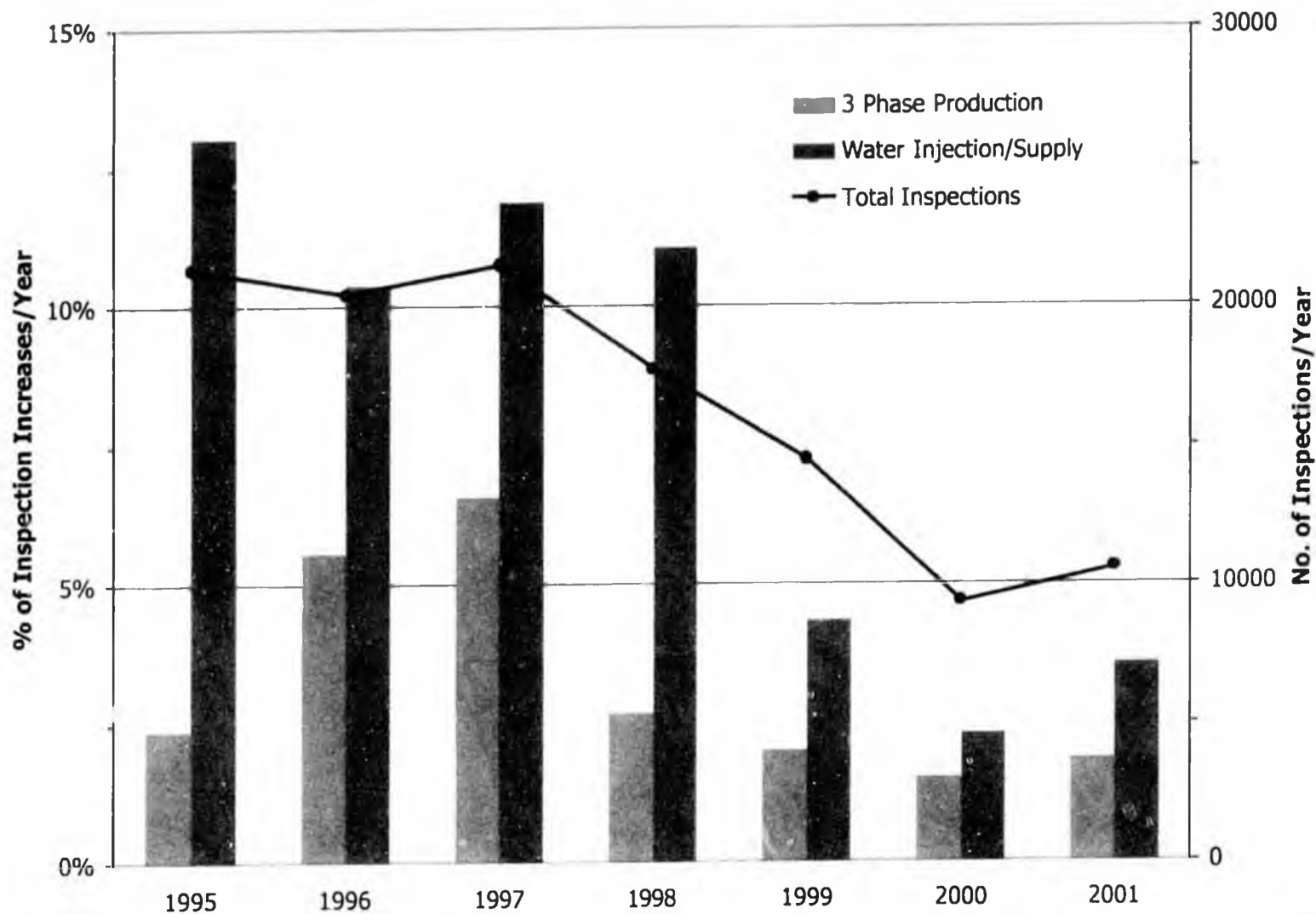



# Well Lines Inspection Increases

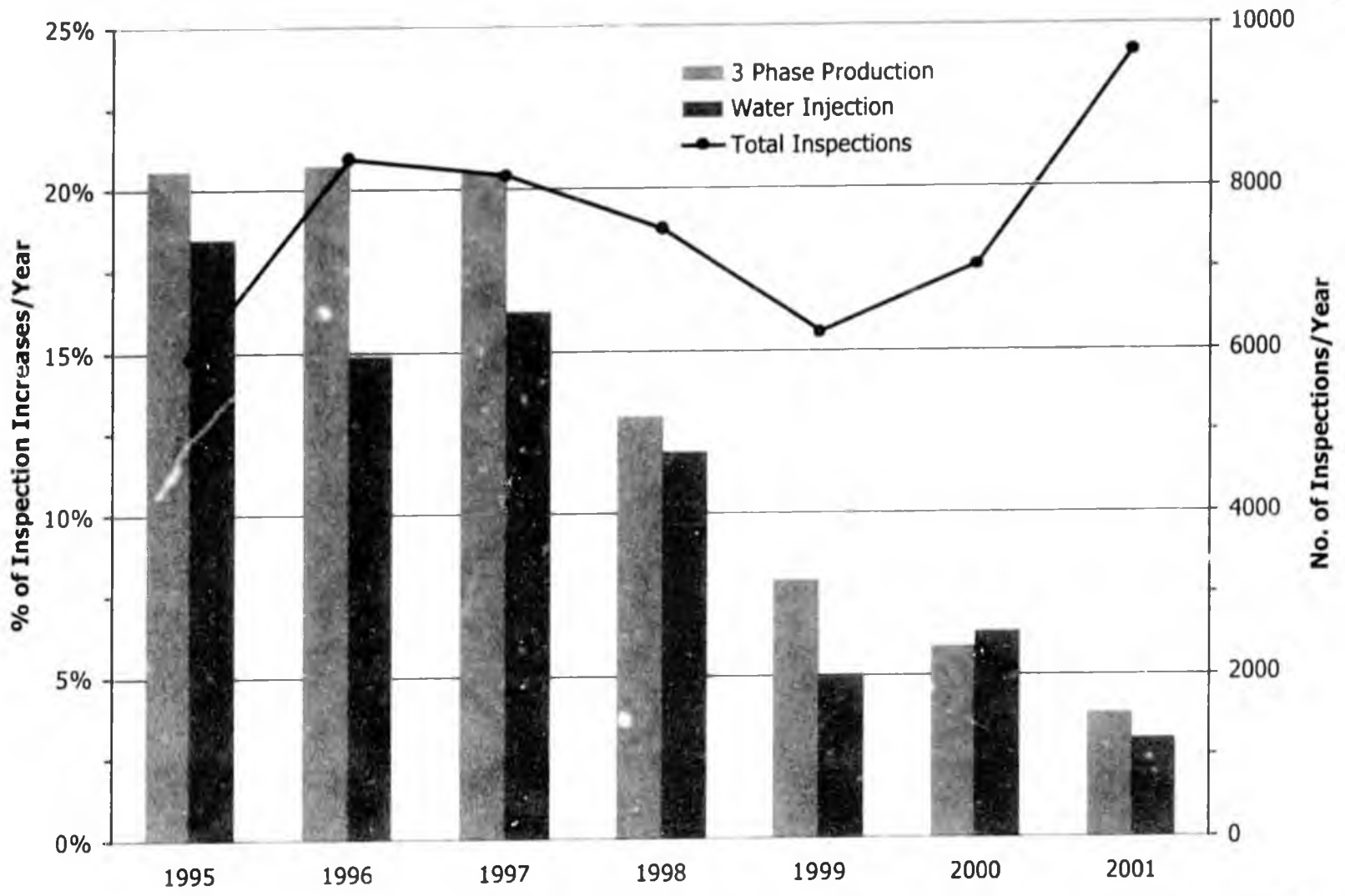

April 2002

BP/ADEC Meet and Confer III



# 3-Phase WLC and Increases Correlation

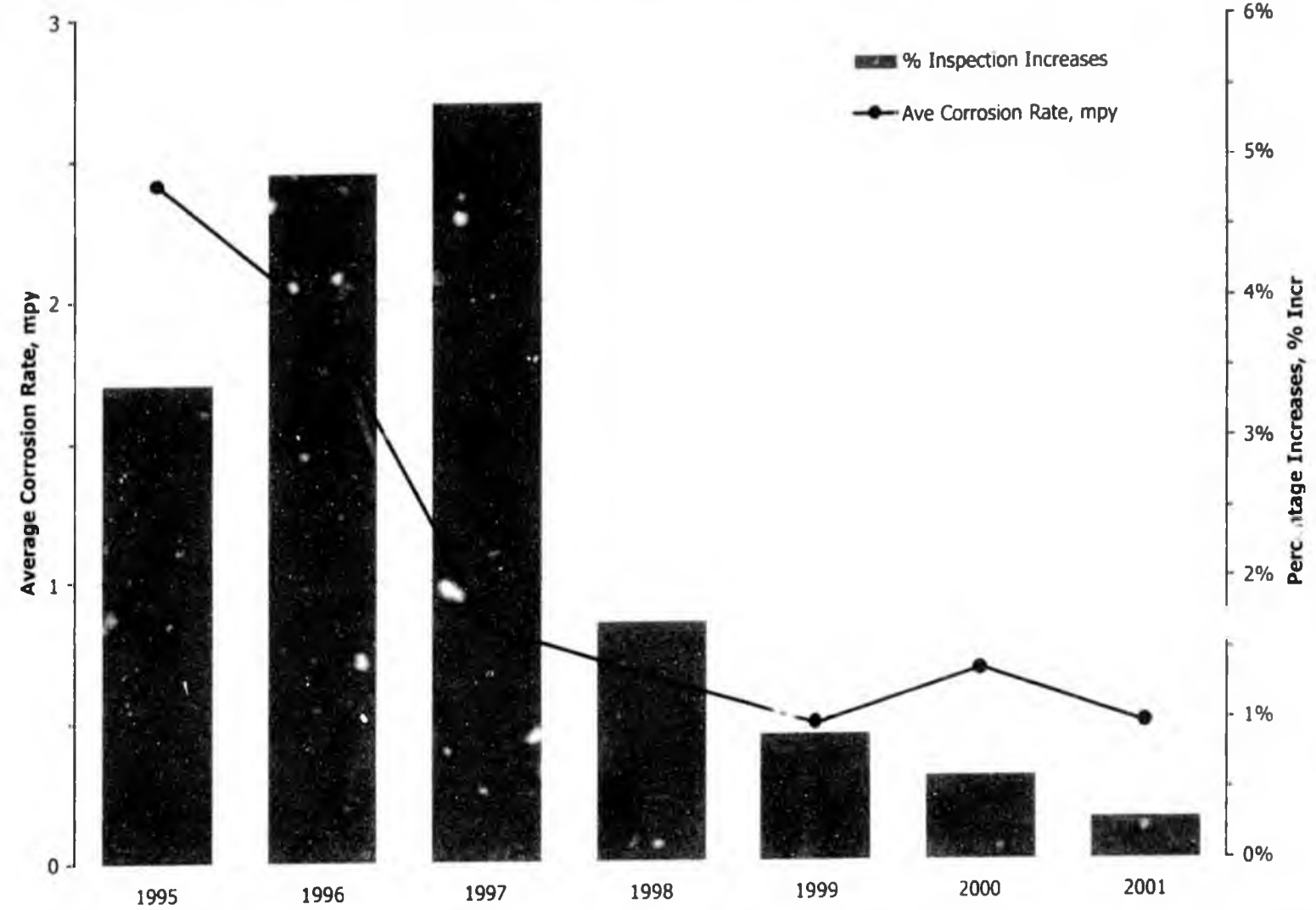

April 2002

BP/ADEC Meet and Confer III



## 3-Phase Flow Line Condition

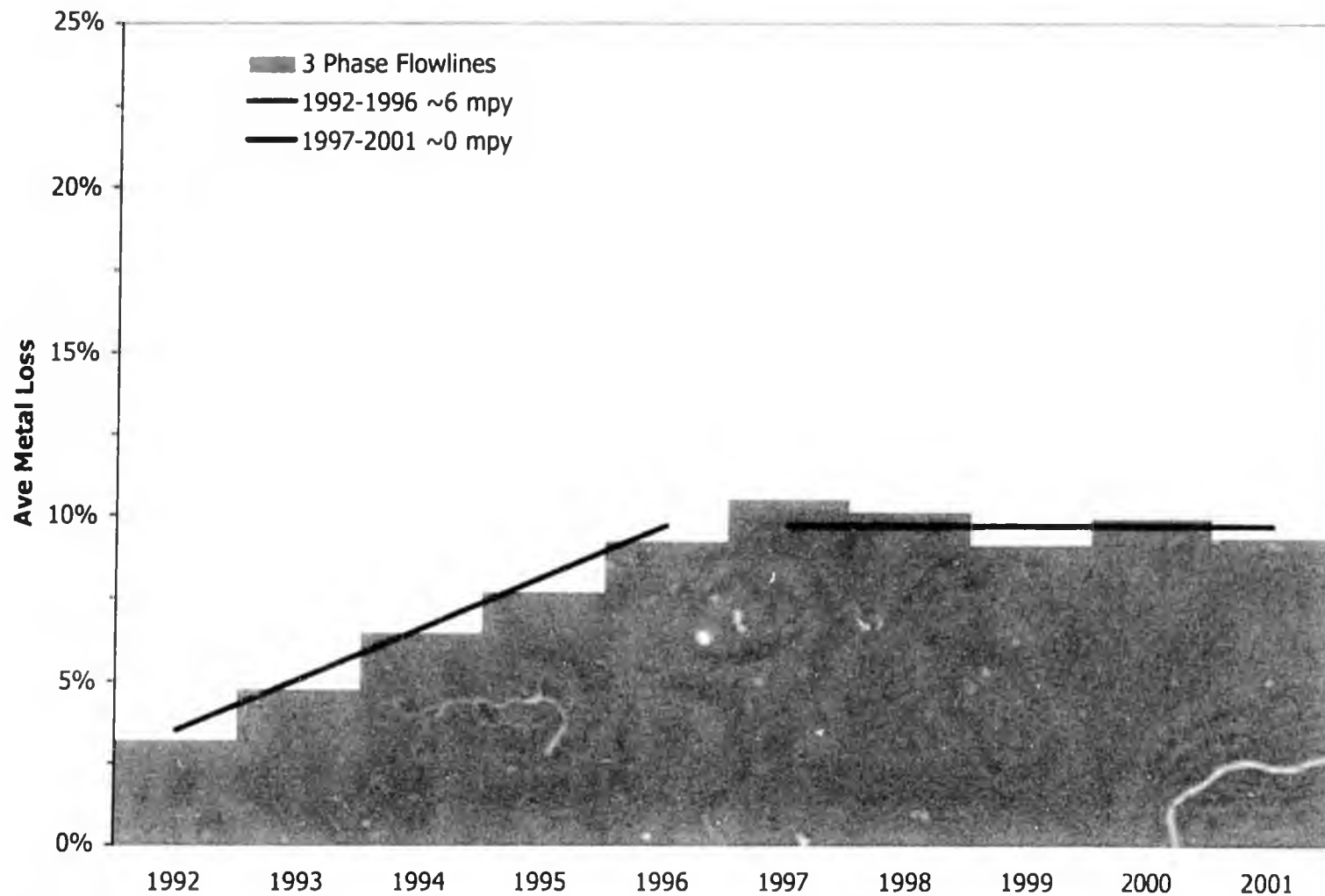

April 2002

BP/ADEC Meet and Confer III

15



# 3-Phase Well Line Condition

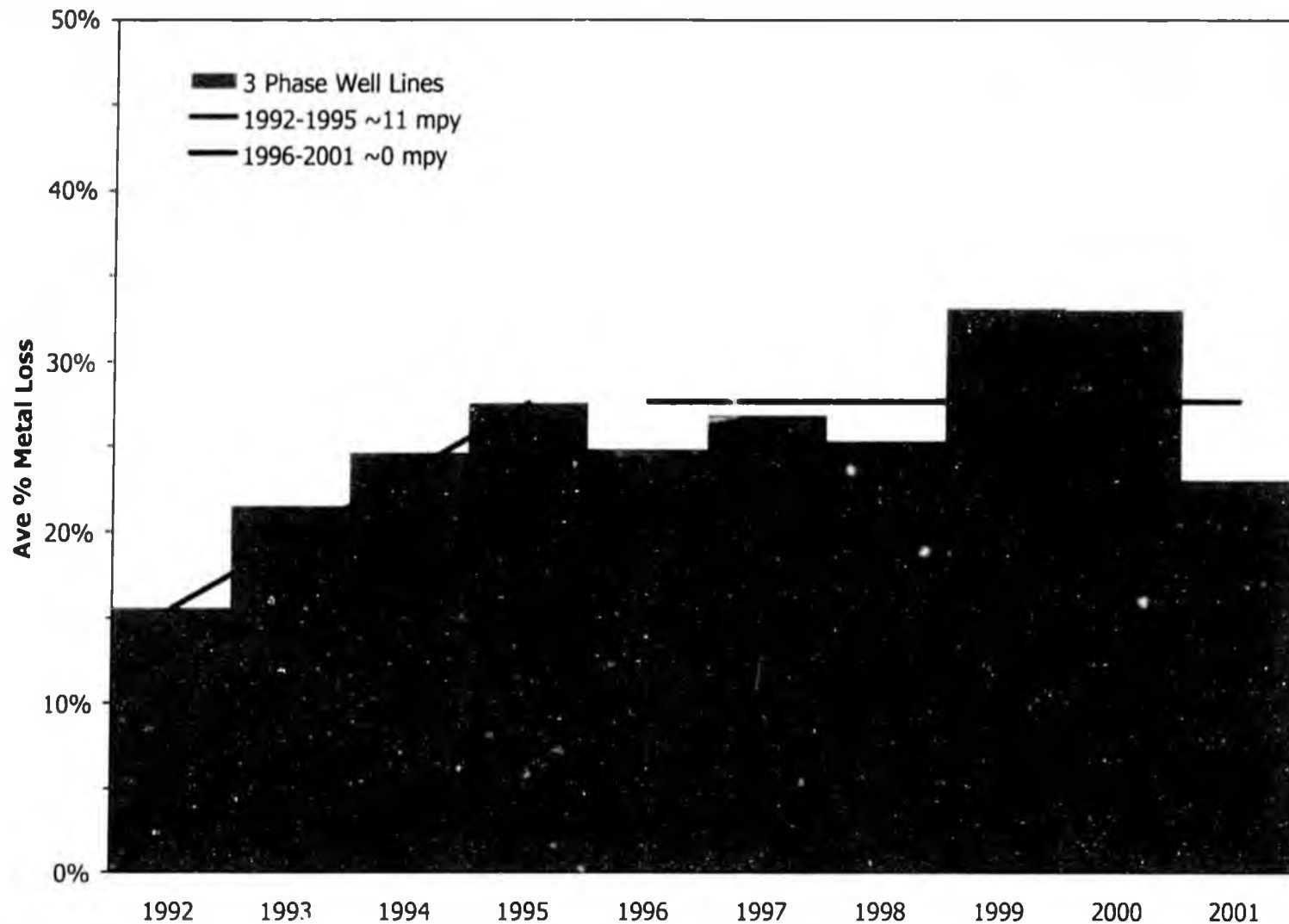



# Inspection Condition and Increases

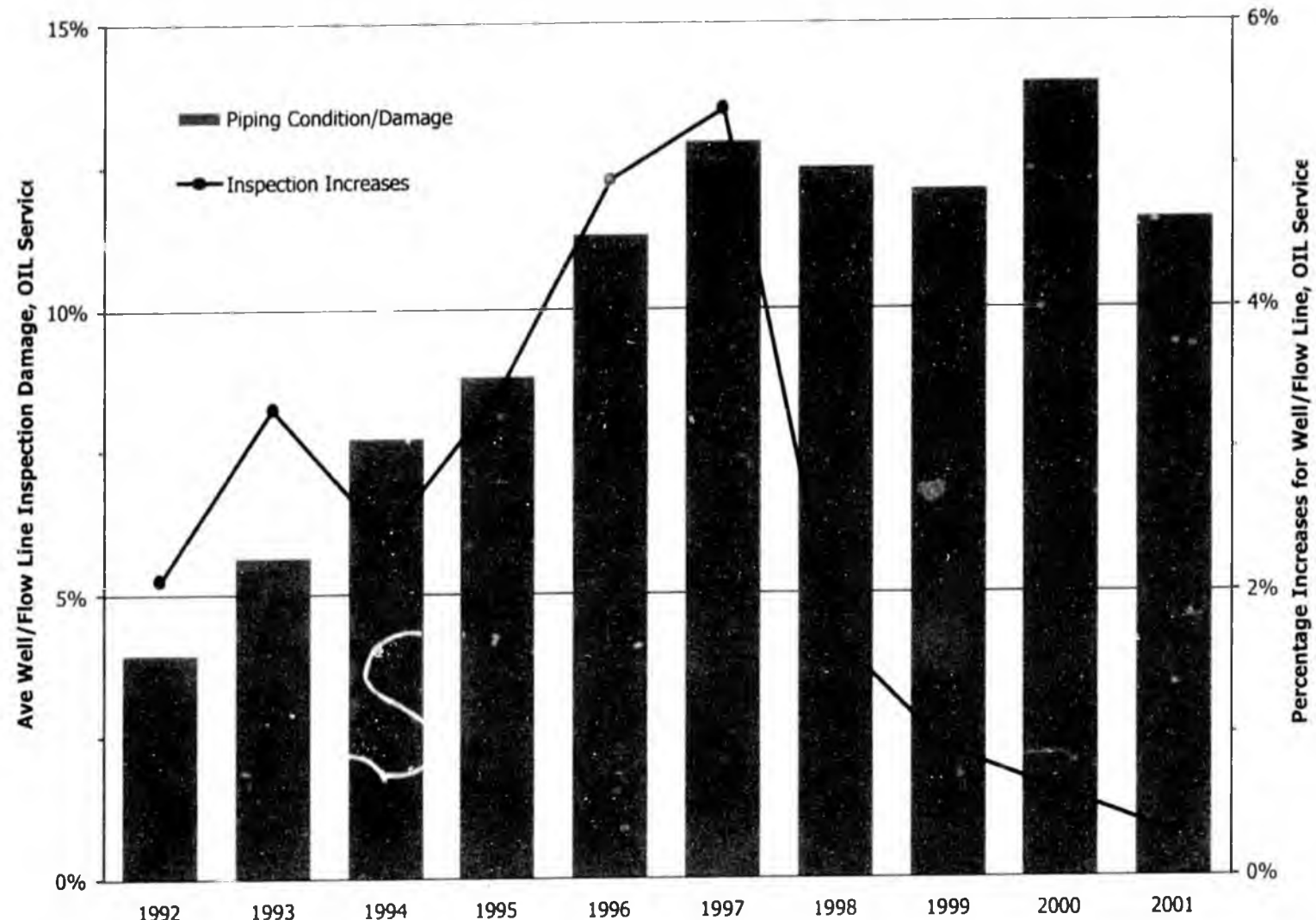

April 2002

BP/ADEC Meet and Confer III



# Mitigation – 3-Phase Corrosion Inhibition

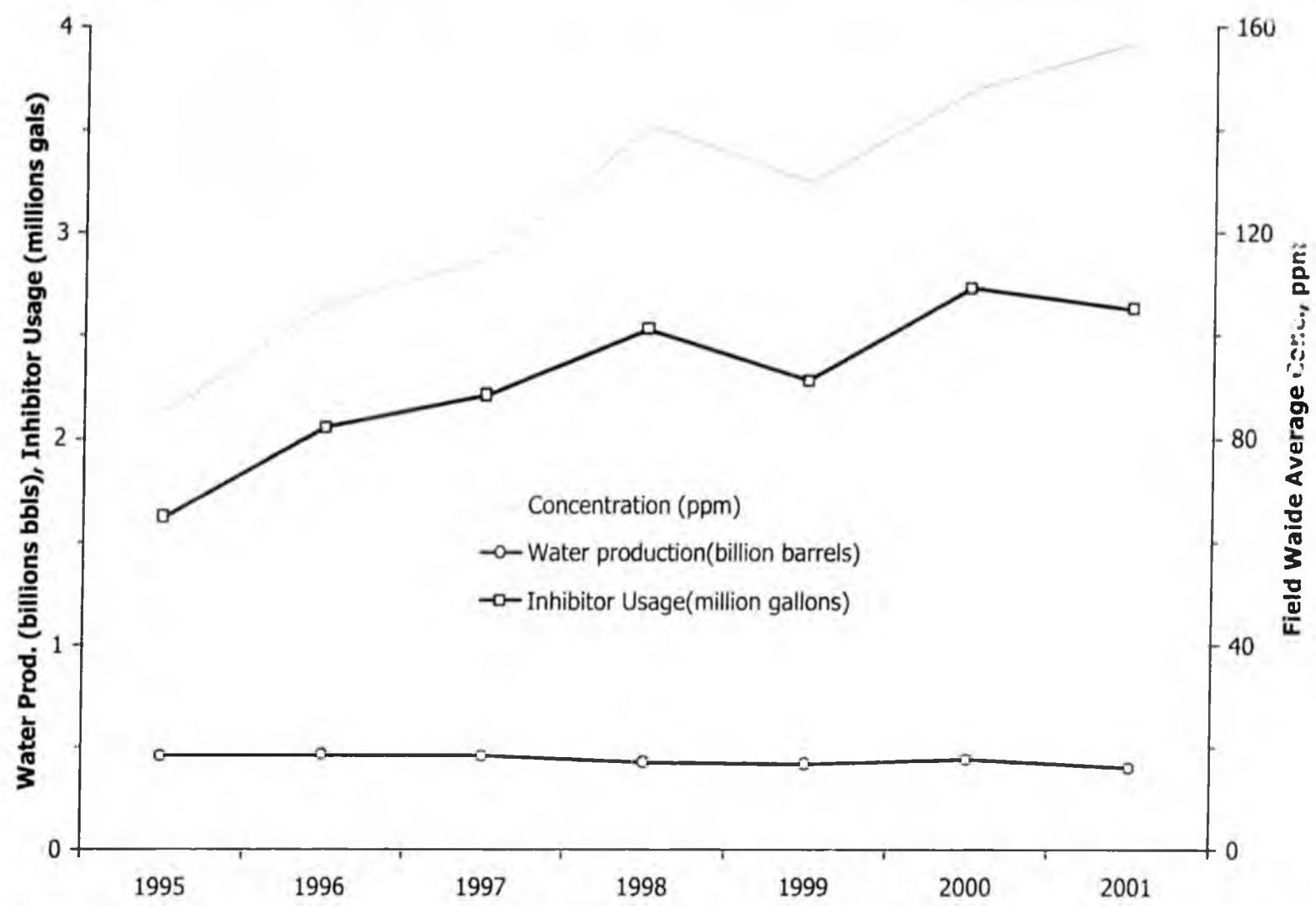



# Correlation Inhibition and Corrosion Rate

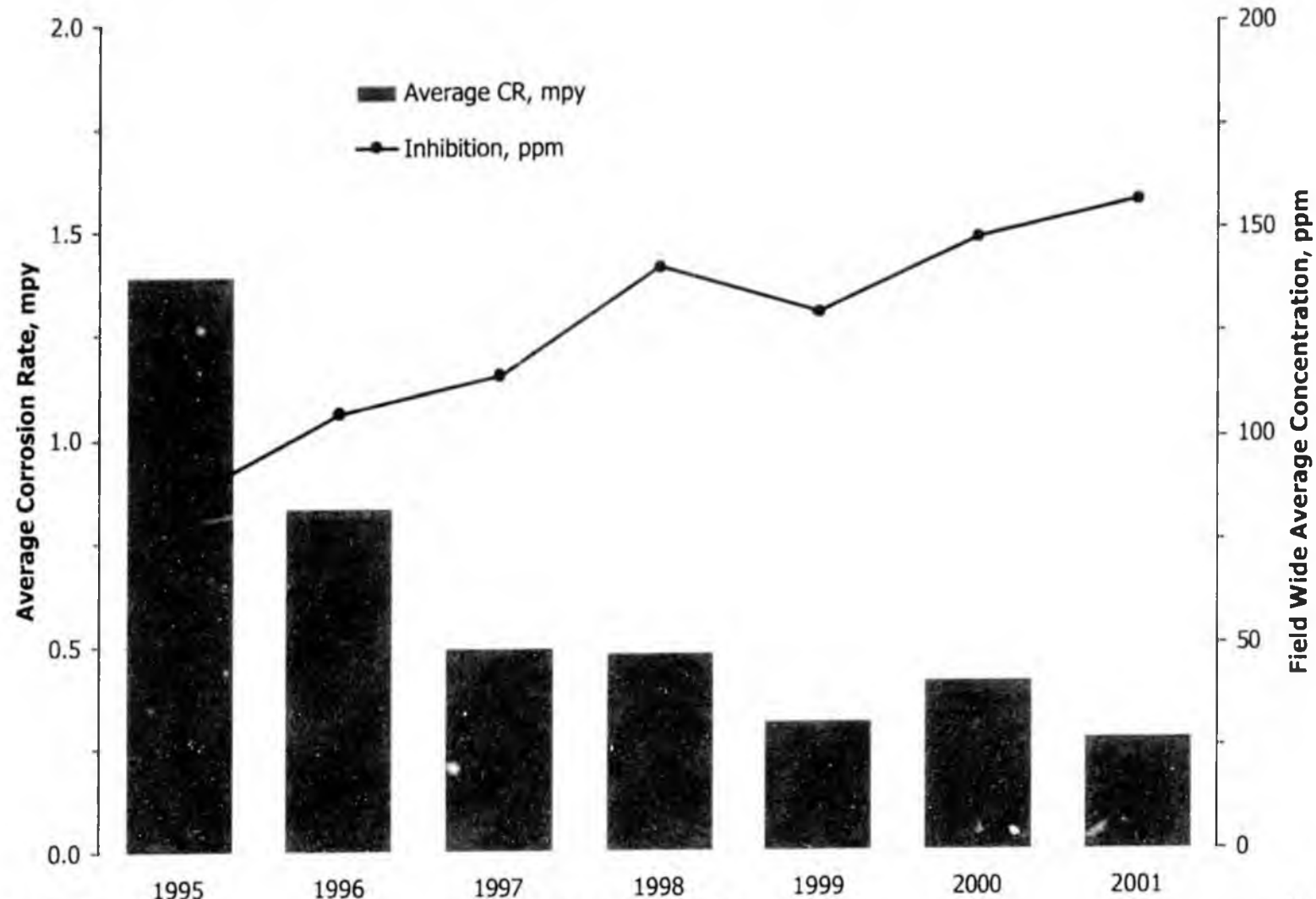

April 2002

BP/ADEC Meet and Confer III

19



## 3-Phase System Corrosion Control

- ▶ **10 Year History**
  - ▶ Substantial reduction
  - ▶ Order of magnitude
    - 3.3 to 0.3 mpy
- ▶ **Mitigation**
  - ▶ Increased concentration
  - ▶ Approximately 50%
- ▶ **Consistency/Correlation**
  - ▶ Inspection vs. monitoring
  - ▶ Monitoring vs. inhibition
- ▶ **Strategy**
  - ▶ Long term integrity
  - ▶ Target CR 2 mpy
- ▶ **2002 Objectives**
  - ▶ Maintain current performance

### 3-Phase Summary

	1992	1996	2001
WLC CR mpy	3.3	0.8	0.3
Condition	4%	11%	12%
Increases	2.1%	4.9%	0.3%
CI Usage 10 <sup>6</sup> gpy	-	2.05	2.63
CI Conc. ppm	-	106	157



# Produced Water (PW) Injection System – WLC

## PW Injection System WLC Corrosion/Pitting Rates

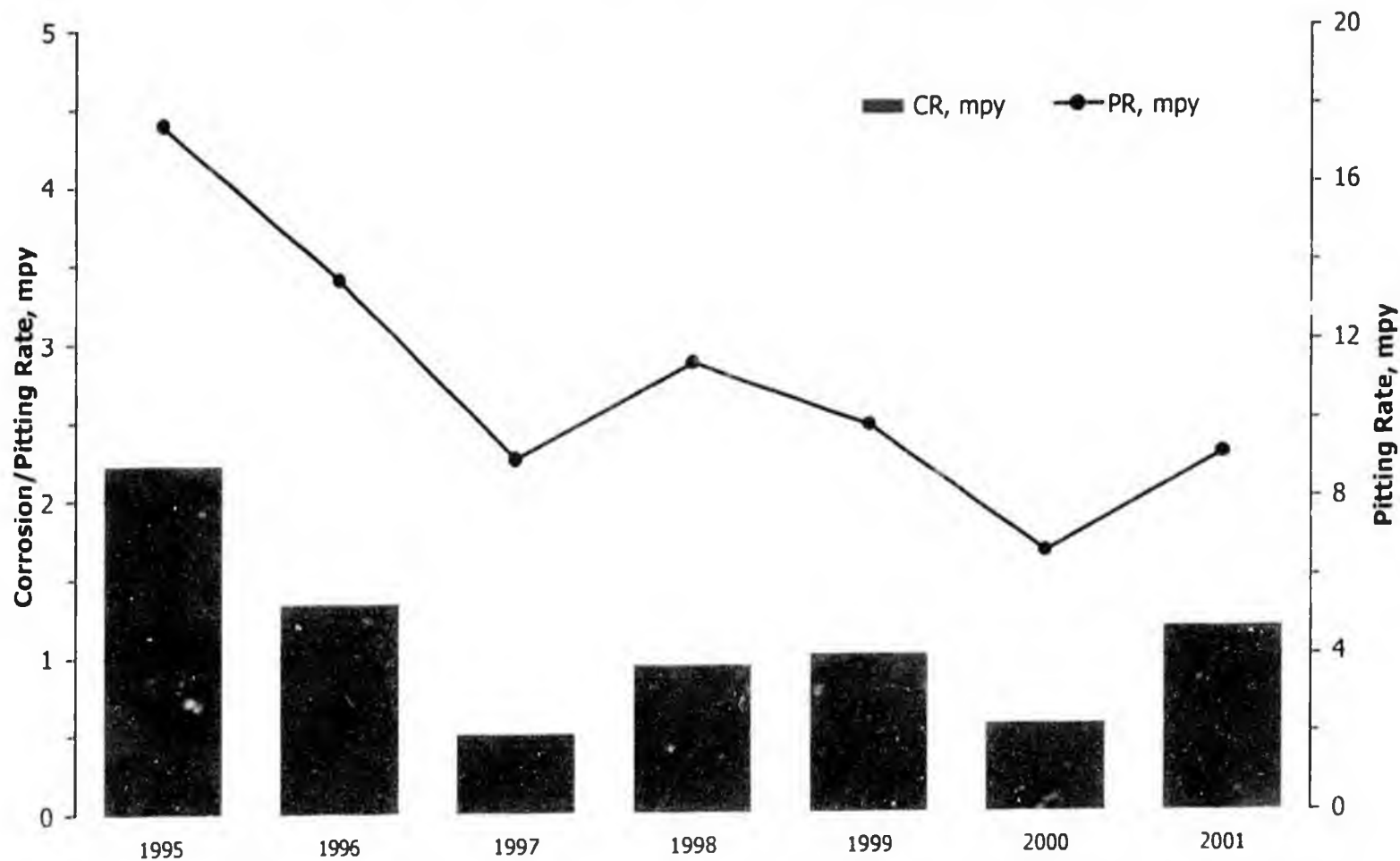



## **Produced Water (PW) Injection System**

- ▶ **Corrosion Rate Trends**
  - ▶▶ Increasing general corrosion rate
  - ▶▶ Increasing pitting rate
- ▶ **Corrosion Inhibition**
  - ▶▶ Trials in 1999 and 2000
  - ▶▶ GC's 1, 2 and 3
- ▶ **Program Expansion**
  - ▶▶ Additional funding in 2002



# Seawater Injection System

## SW System WLC Corrosion and Pitting Rates

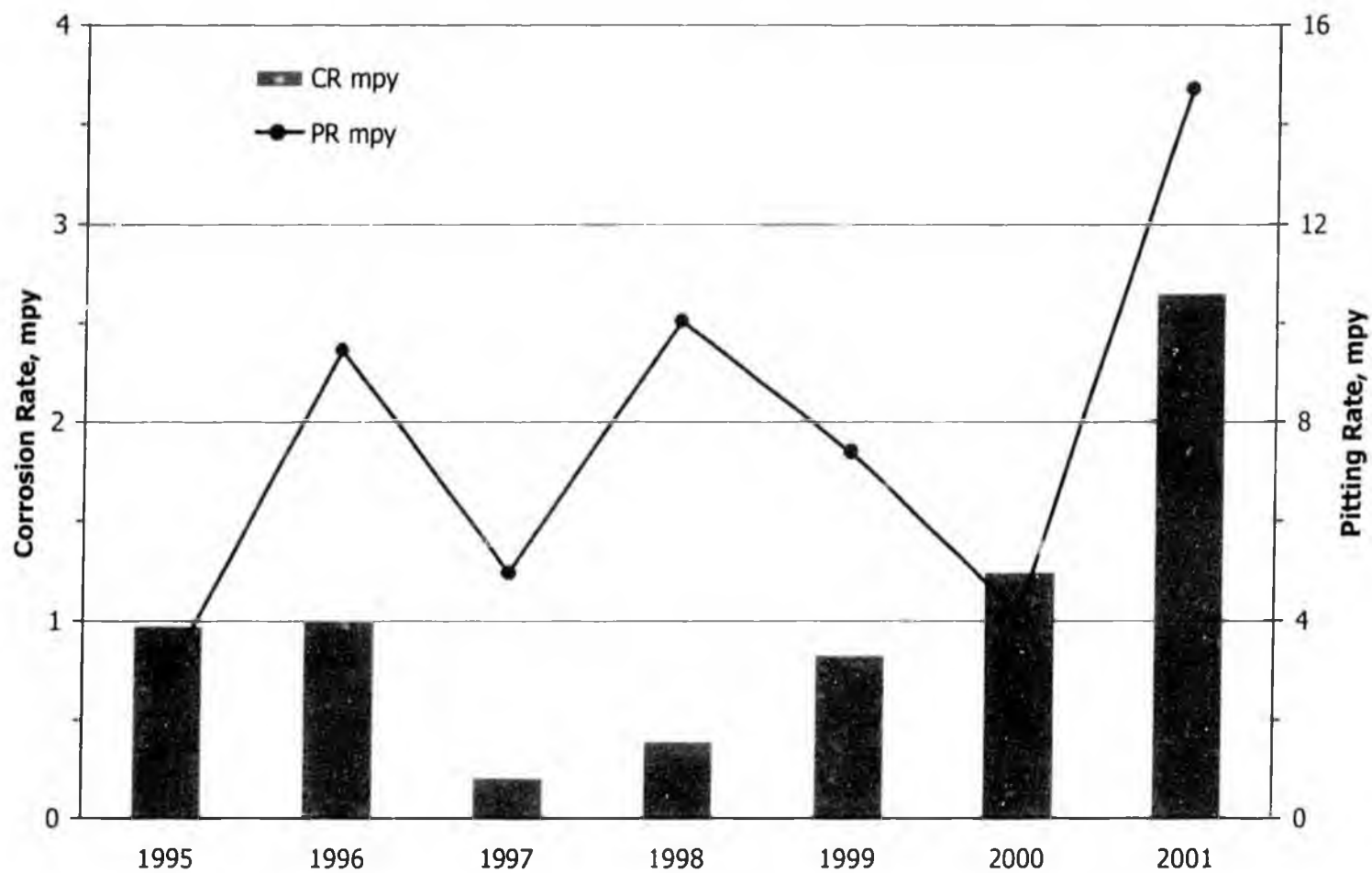



## **SW Injection System – Corrective Actions**

### **▶ Corrosion Mechanisms**

- ▶ Dissolved oxygen
- ▶ Microbiological

### **▶ Corrosion Trends**

- ▶ Increasing corrosion and pitting rates

### **▶ Corrective Action Plans**

- ▶ Oxygen control
  - Residual dissolved oxygen (DO) target < 20 ppb
  - Upgraded DO meter
  - Antifoam added to the vacuum tower
  - O<sub>2</sub> scavenger performance improvement
    - Catalyzed for low O<sub>2</sub> concentrations and lower temperatures
- ▶ Microbiological control
  - More effective biocide blend
  - Doubled frequency of maintenance pigging
- ▶ Plant repair and maintenance
  - Preparation for SW volume ramp-up planned for 2002-2003



## External Corrosion Program

- ▶ **External Corrosion**
  - ▶▶ Field applied insulation joints at weld packs
- ▶ **Scope**
  - ▶▶ All cross-country flow lines and well lines
  - ▶▶ ~200,000 weld packs off-pad
  - ▶▶ ~100,000 weld packs on-pad
- ▶ **Main Challenge**
  - ▶▶ Detection of external corrosion damage
- ▶ **Recurring Screening**
  - ▶▶ Prioritization
    - Configuration
    - Ave temperature
    - Age of equipment
    - Previous inspection



# External Corrosion – Inspection Activity

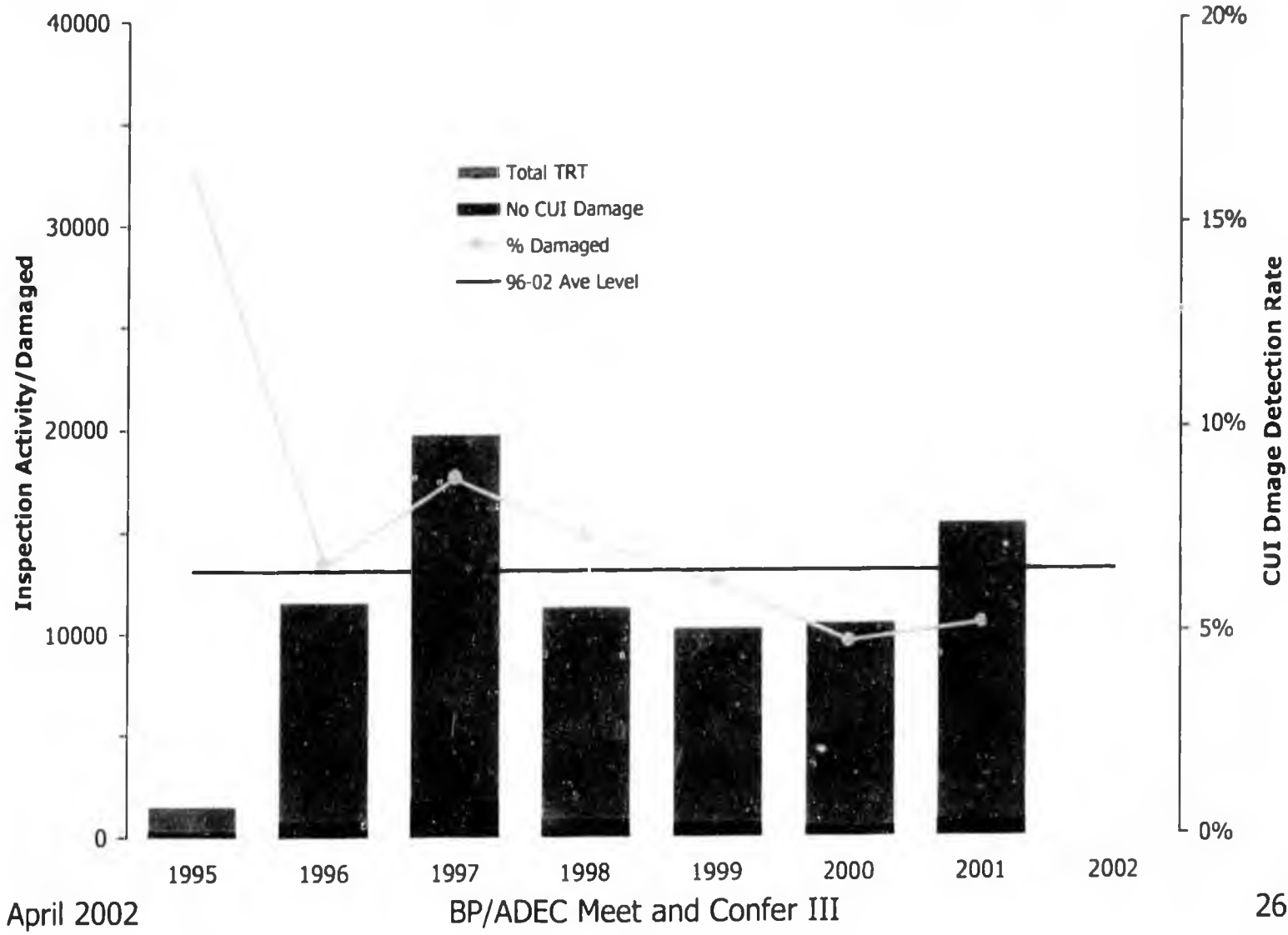



## **External Corrosion – Way Forward**

### **▶ Activity Level**

- ▶▶ ~13,000 locations/yr since 1996

### **▶ Level of Risk**

- ▶▶ Process review with GPB partners
- ▶▶ Identified increasing risk as field ages
- ▶▶ Joint configuration and location
  - Greater influences on occurrence of CUI

### **▶ 2002 Program Expansion**

- ▶▶ Inspection scope increase to approx. 35,000 locations



## Cased Piping Program

### ▶ Scope

- ▶▶ 460 road/caribou crossings (GPB & ACT)
- ▶▶ Complete initial baseline by 2003

### ▶ Results

- ▶▶ ~60% of scope completed
- ▶▶ 281 inspected in 2001(GPB & ACT)
- ▶▶ GPB
  - 34 with 'minor' damage
  - 2 with 'moderate' damage
- ▶▶ ACT
  - 30 digs on buried flow lines and/or headers at MPU
  - 3 locations repaired



# 2001 Program Performance I

## ▶ 6 Corrosion Related Leaks in 2002

### Corrosion Related Leak Summary

Service	Location	Type	Date	Mechanism	Volume
3 phase production	DS-01	WL	14-Jul-2001	Ext	200 gal
3 phase production	Pt Mac CL	FL	21-Jul-2001	Ext	420 gal
Produced Water	DS-14	WL	16-Aug-2001	Int	5 gal
3 phase production	DS-15	WL	23-Dec-2001	Int	5 gal
3 phase production	DS-07	WL	19-Feb-2001	Erosion	280 barrels
G&I Slurry	G&I	FL	6-Mar-2001	Erosion	400 barrels

	Surface		Service			Mechanism		
	Int	Ext	OIL	SW	PW	CO <sub>2</sub>	Erosion	CUI
WL	3	1	3		1	2	1	1
FL	1	1	1	1			1	1

## ▶ Repairs

### ▶▶ 31 repairs

- 17 – external corrosion
- 11 – internal/erosion
- 3 – mechanical damage



## 2001 Program Performance II

### ▶ ER Probe Corrective Actions

Equipment ID	Cause	Action
N-74	Increased Corrosivity	See Inspection CA
09A	Increased Corrosivity	See Inspection CA
12C	Increased Corrosivity	Increased CI by 10%
04B	Increased Corrosivity	Increased CI by 5%
03D	Increased Corrosivity	Increased CI by 10%
14D	Increased Corrosivity	See Coupon CA

### ▶ Coupon Corrective Actions

Equipment ID	Cause	Action
U-384	Poor water values	New procedure for CI distribution
Y-74	Poor water values	New procedure for CI distribution
Q Pad	Increased Corrosivity	Increased CI by 20%
14D	Increased Corrosivity	Increased CI by 10%
07C/15C	Possible under injection	Now checking rates
N-74	Increased Corrosivity	See Inspection CA
07D (Pit Rate)	Possible under injection	Under investigation



## 2001 Program Performance III

### ▶ Inspection Corrective Actions

Equipment ID	Cause	Action
09E	Increased Corrosivity	Increased CI by 10%
04C	Increased Corrosivity	Increased CI by 10%
E-46 (K Pad)	Increased Corrosivity	Increased CI by 75%
S-36	Increased Corrosivity	Increased CI by 10%
Z-74	Increased Corrosivity	Increased CI by 20%
N-74	Increased Corrosivity	Increased CI by 25%
09A	Increased Corrosivity	Increased CI by 10%
G-42	Increased Corrosivity	Increased CI by 150%
H-36	Increased Corrosivity	Increased CI by 10%
PW System	Change Upstream CI	Changed Upstream CI 1Q02
SW System	Increased O <sub>2</sub> Content	Increased O <sub>2</sub> Control

### ▶ Program Improvement

- ▶▶ PW system – additional inhibition
- ▶▶ SW system – O<sub>2</sub> control

### ▶ Program Continuity

- ▶▶ 3-phase production



## 2002 Overview – Main Issues

- ▶ **Maintain Three-Phase System**
- ▶ **SW/PW Program Improvement**
  - ▶▶ Seawater
    - Performance improvement from implemented corrective actions
    - Additional actions as required
  - ▶▶ Produced water
    - Monitor effectiveness of supplemental corrosion inhibitor
    - Optimize as appropriate
- ▶ **Inspection Program**
  - ▶▶ Implementation of expanded External Corrosion Program
    - ~35,000 items
  - ▶▶ Baseline inspection of cased piping segments
    - ~200 segments to be inspected in 2002
    - On target to complete in 2003



## Summary

- ▶ **Delivery of Objectives**
  - ▶▶ Long term Fitness For Service
- ▶ **Corrosion Management System**
  - ▶▶ Integration of key elements
    - Thickness – Inspection program
    - Rate – Corrosion monitoring
    - Mitigation – Corrosion inhibition
- ▶ **System Review**
  - ▶▶ 3-Phase – Improved from 2000
  - ▶▶ SW – Deteriorated from 2000
  - ▶▶ PW – Deteriorated from 2000
- ▶ **Focus for 2002**
  - ▶▶ 3-Phase – Maintain performance
  - ▶▶ SW – Dissolved oxygen control
  - ▶▶ PW – Additional inhibition

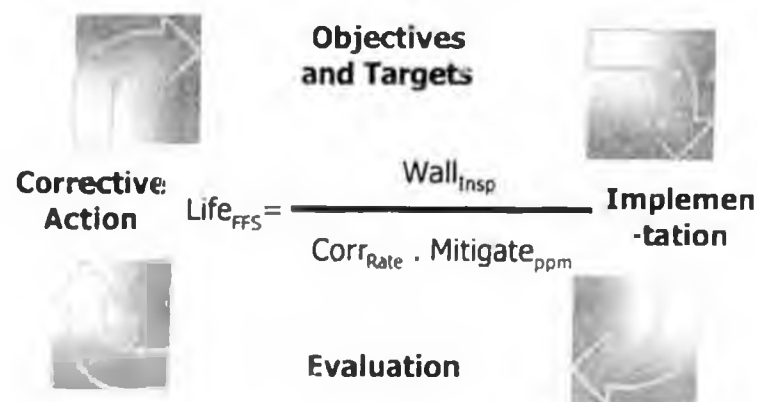

CPA



---

# **Greater Kuparuk Area**

## **Commitment To Corrosion Monitoring Overview**

presented to the

Alaska Department of Environmental Conservation

*3rd Meet & Confer*

April 29, 2002



# Inspection Results

## Internal Corrosion



### Cross Country Lines

Corrosion Is Under Control

- ✓ Nearly tripled original RTR work scope (from 10M to 28M feet)
- ✓ Over 30,000 ft of over 100 lines inspected (RTR and RT)
- ✓ No significant damage noted
- ✓ 0 Leaks, 0 Saves

# 2001

### Internal Corrosion Spills - Cross Country Lines

1994 Spill 24" 1Y/R Crude CC Line

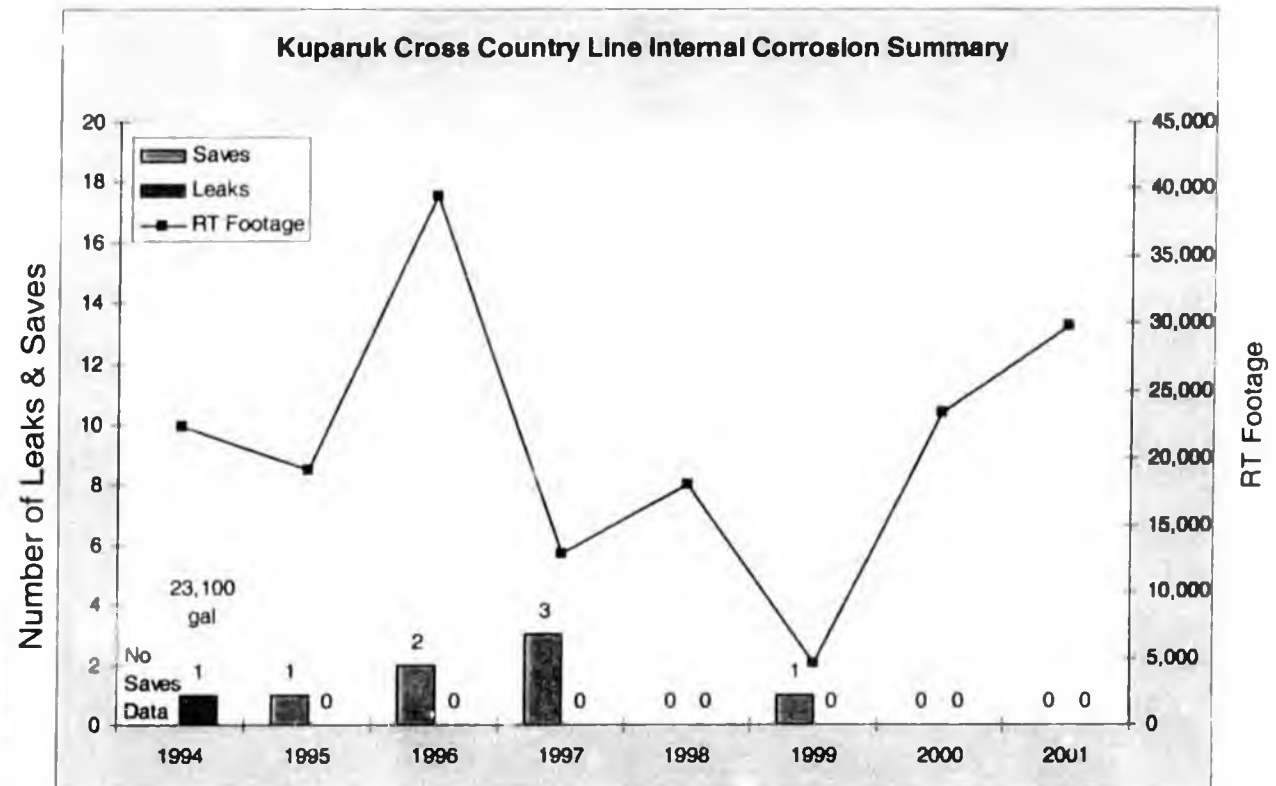



# Inspection Results

## Internal Corrosion



### Well Lines

Internal Inspection Focus Area

# 2001

- ✓ Tripled original RTR work scope (from 18M to over 58M feet)
- ✓ Roughly 1/2 of all GKA well lines RTR'd (431 of ~900 lines)
- ✓ Most .280" and .312" well lines inspected (remainder of .280" in Jan '02)
- ✓ 24 well lines required repair (17 injectors, 7 producers)
- ✓ 0 Leaks, 24 Saves

#### Internal Corrosion Spills -Well Lines

1998 Spills	1L-1 6" WI Line
	1L-3 6" WI Line
	1A-9 6" WI Line
2000 Spill	1G-8 6" PC Line

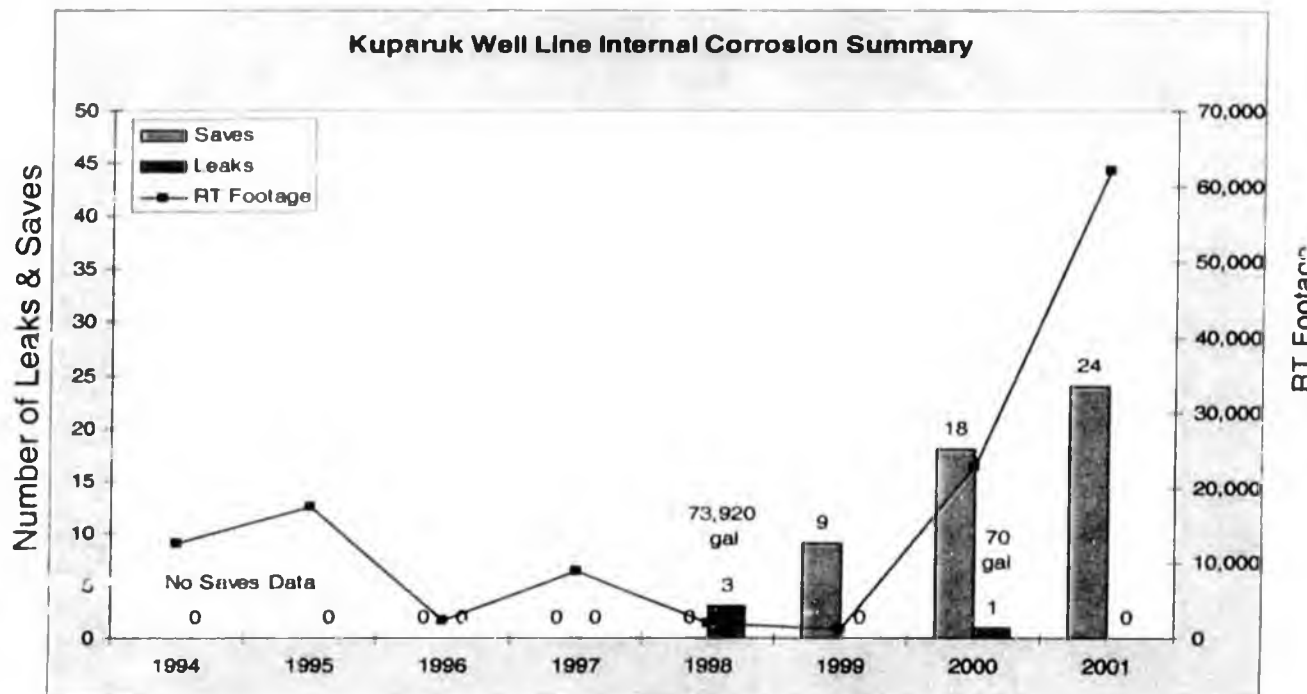



# Inspection Results

## Internal Corrosion



2002 Goals

- ✓ **Continue to Focus on and Inspect Well Lines**  
(Priority Based on Wall Thickness and Age of Line)
  - Complete initial inspection of all remaining 0.312" well lines (~60 lines)
  - Target next group of 0.375" well lines
  - Similar effort as 2001 (footage will decrease due to pipe configurations)
- ✓ **Maintain Inspection of Cross Country Lines**
  - Similar effort and footage as 2001
  - Fully integrate Risk Based Elbow Program into CC Line inspection efforts
  - Evaluate possibility of smart pigging water injection CC Lines > 10in Diameter  
*(these = 1/2 of all CC lines)*



# Monitoring/Mitigation



## Results & Accomplishments

2001

### Monitoring:

- ✓ For all service categories, coupon general and pitting rate averages remain under threshold limits
- ✓ Over 90% of 3-Phase Production CC lines with ER probe rates < 2 mpy
- ✓ Inspection of CC water lines shows routine maintenance pigging combined with residual corrosion inhibitor carryover controls corrosion

### Mitigation:

- ✓ Inspection data shows corrosion is under control in the cross country lines
- ✓ All inhibited 3-Phase Production CC lines with probe, coupon, or inspection rates above thresholds had corrective action taken (inhibitor rates were increased)
- ✓ Continuous wellhead injection project at DS1G funded and proceeding
  - Additional Drill Sites installations funded; design & procurement in progress
- ✓ Field-wide corrosion inhibitor injection rate control improved

*- to be running before end of 2002*

## Summary 2001

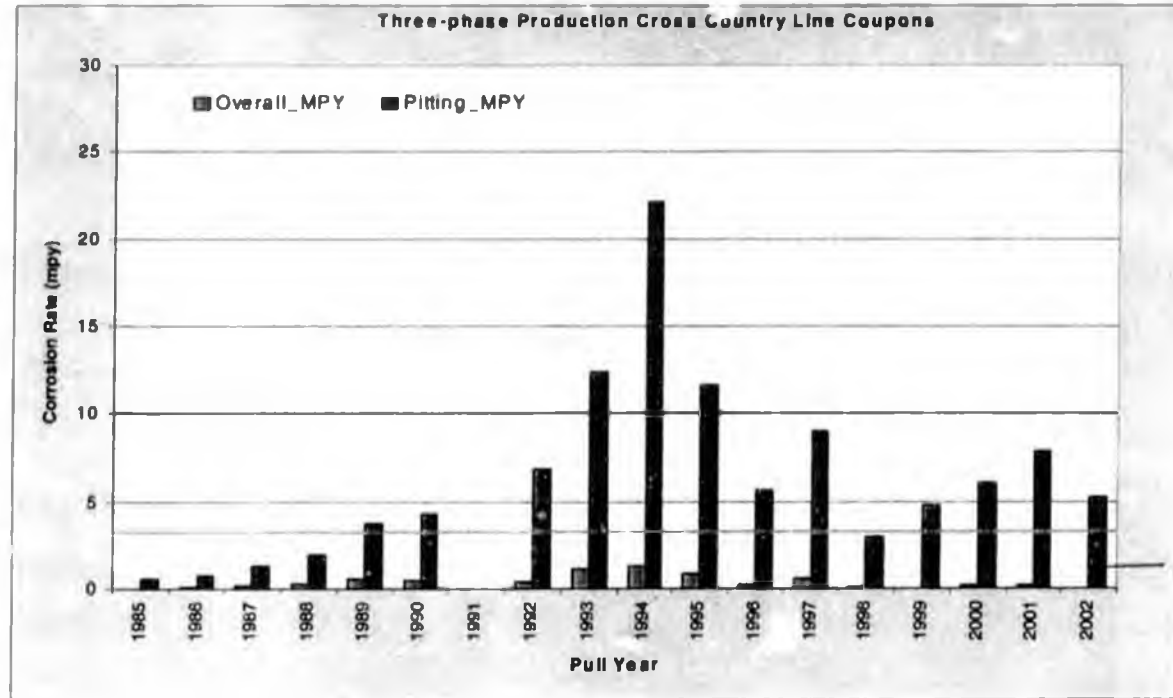

- ✓ Coupon average corrosion rates under threshold limits, but trends were increasing as of YE2001. Note improvement due to inhibitor changes in late 2001...
- ✓ Coupon corrosion rates are a conservative measure, and are a warning indicator
  - Inhibitor concentration increased on twice as many lines due to coupon/probe data than due to inspection increases
- ✓ Inspection data shows corrosion is under control in the CC lines
  - Less than 3% of repeat inspections showed increases



# Monitoring/Mitigation

## Three-Phase Cross Country Lines

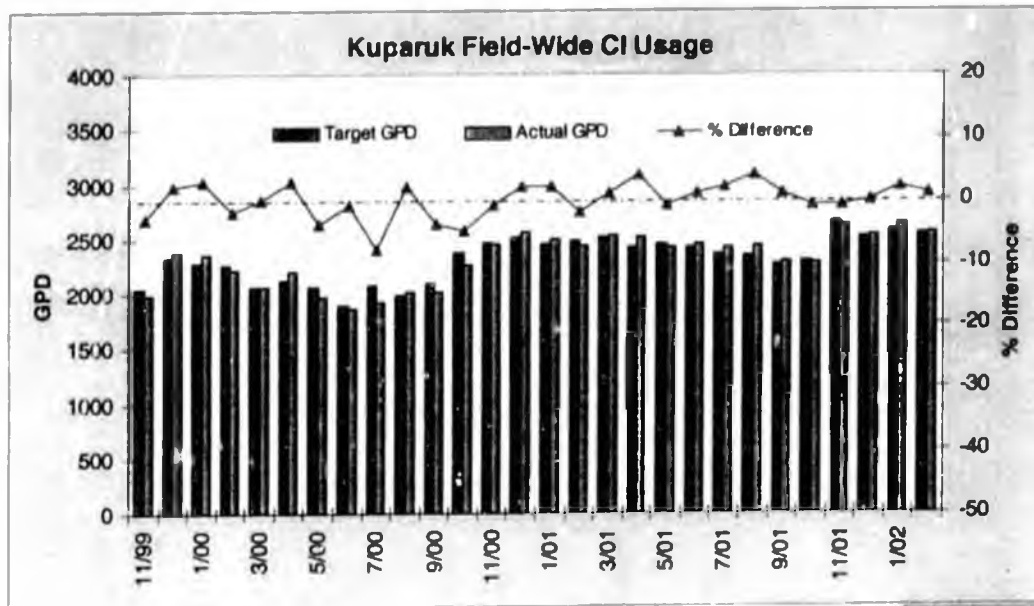
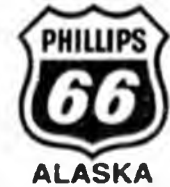

### Corrosion Inhibitor Usage:

- ✓ Goal is zero percent difference, with a bias toward staying above rather than below zero
- ✓ Using better reporting tools, field-wide corrosion inhibitor control improved during 2001

### Corrosion Inhibitor Concentration: >>>

- ✓ Field-wide corrosion inhibitor target concentration has increased in response to monitoring/inspection feedback

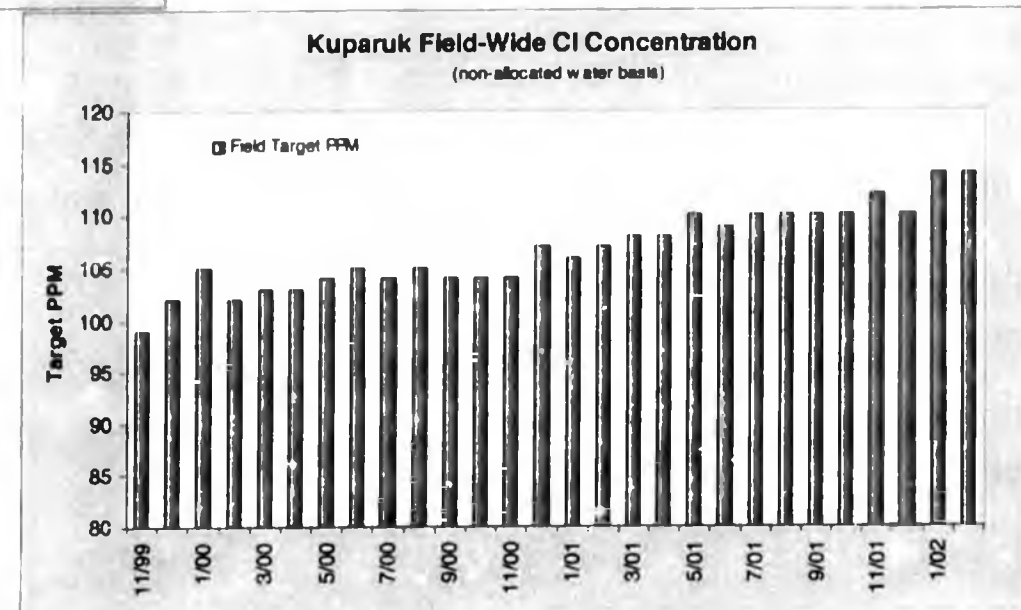

## 2002 Goals

- ✓ **Find more effective corrosion inhibitors**
  - Implement RU-276 field-wide by end of 1<sup>st</sup> quarter (Complete)
  - Although coupon average corrosion rates are under threshold limits, the trends are moving up
  - New field testing protocol will accelerate the development/screening of new CI chemistries
- ✓ **Implement wellhead continuous injection**
  - Start pumping corrosion inhibitor at DS1G well head locations. Evaluate effectiveness in well lines
- ✓ **Develop cost effective approach to reduce solids in WI well lines**
  - Test Schmoo-Be-Gone in the water injection system at a Drill Site  
(cleaning surfactant)



# Inspection Results

## External Corrosion



# Summary 2001

Type of Equipment	Number of Locations Inspected	Number of Corroded Locations	Percentage of Locations Corroded	Number of Locations Refurbished
Cross-Country Lines On Pad	3919	102	2.6	257
Cross-Country Lines Over Tundra (Off-Pad)	292	13	4.5	338
Well Lines	5489	64	1.2	227
<b>Total</b>	<b>9700</b>	<b>179</b>	<b>1.9</b>	<b>822</b>

Historical GKA External Leaks and Saves

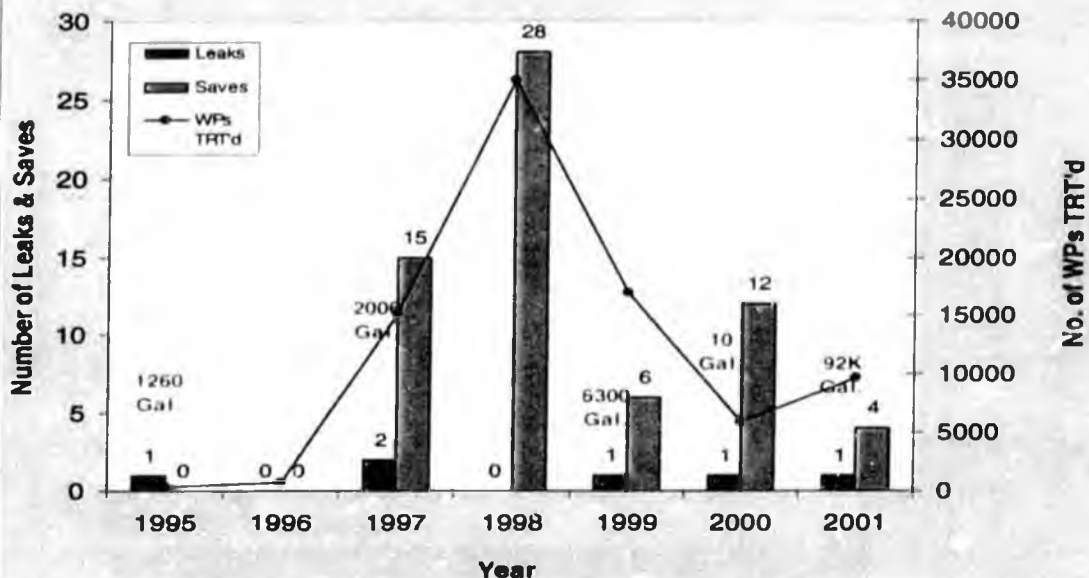

### External Corrosion Line Failure History

- 1995 2C-04 Well Line
- 1997 2 ea. 24" Crude CC Lines (Weld Pack @ Saddle)
- 1999 1A-15 Well Line (Weld Pack @ Saddle)
- 2000 2X-16 Well Line
- 2001 10" CC PWI Line (Weld Pack in Road Crossing)



# Inspection Results

## Cross Country Lines External Corrosion

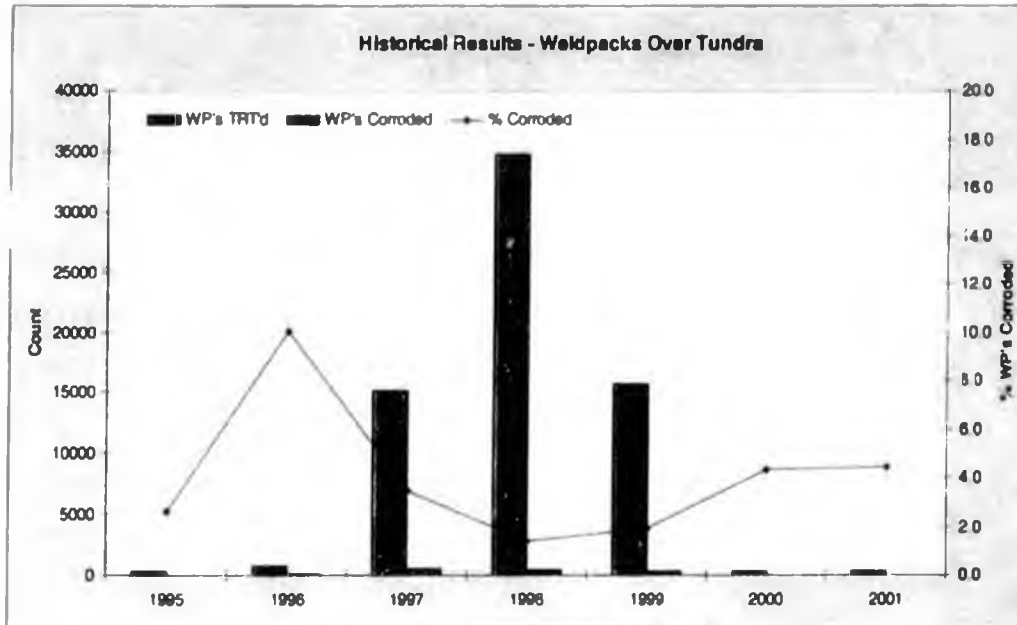

Prioritizing Lines Has Helped Effort

←← CC Lines Over Tundra:

- ✓ All over-tundra cross country weld packs were TRT'd by YE 2001
- ✓ All over tundra cross country weld packs found with corrosion were refurbished by YE 2001

CC Lines On Pad: ⇒⇒

- ✓ TRT'd 3919 on pad cross country weld packs (44% of total) exceeding the goal by 120%
- ✓ 62% of all on pad cross-country line weld packs have been TRT'd YE 2001
- ✓ The % corroded weld packs found has remained nearly the same, ~ 2.6%

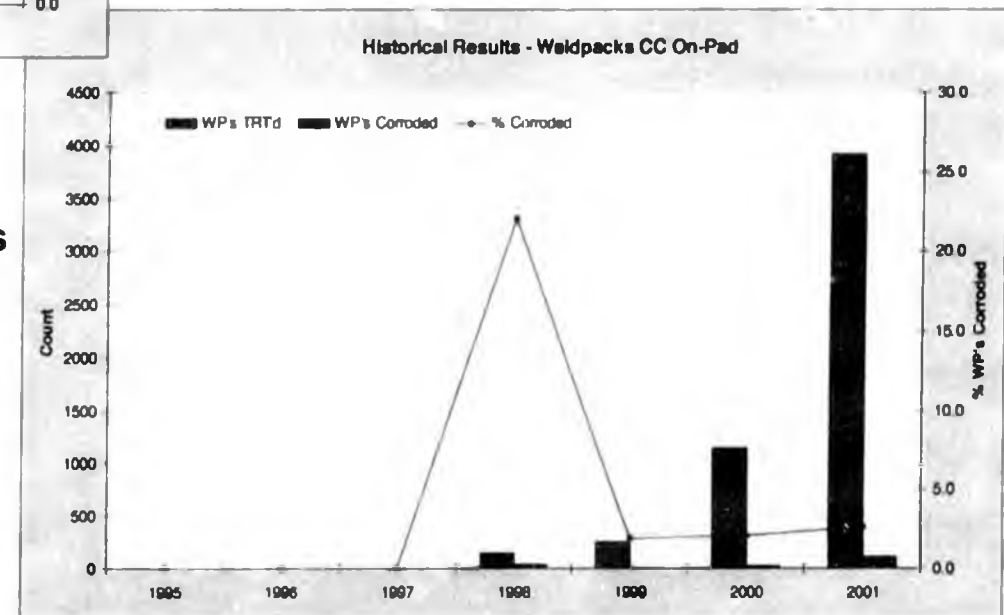



# Inspection Results

## Well Lines External Corrosion

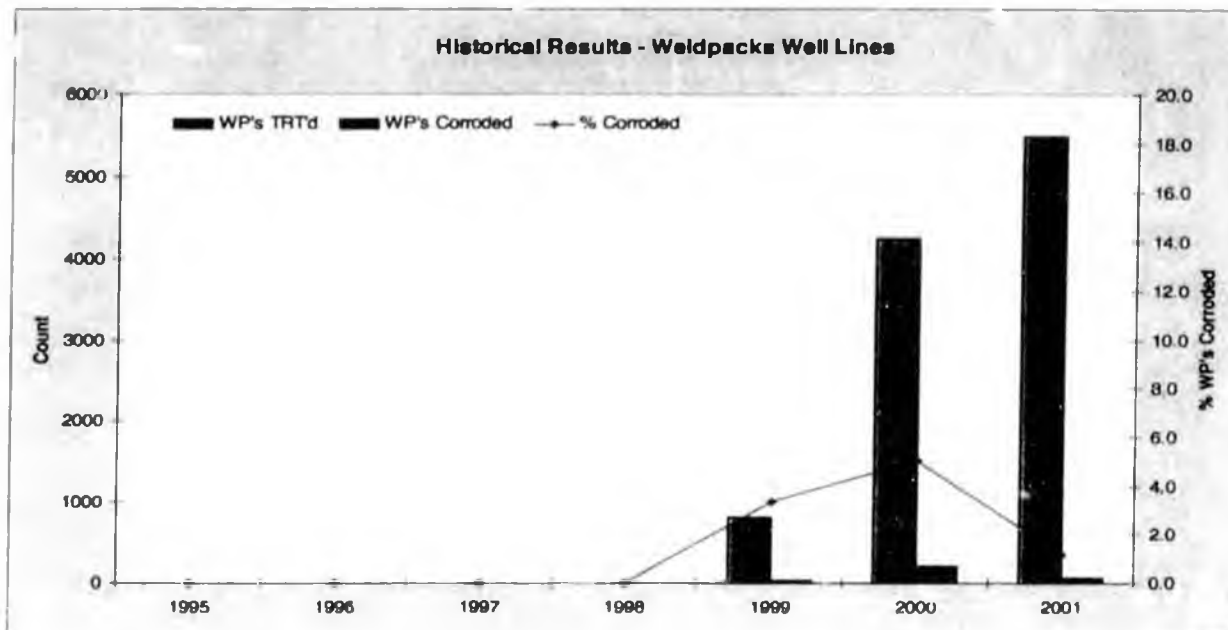

External Corrosion Program is Maturing as expected – Delivering desired results

### Well Lines :

- ✓ TRT'd 5489 well line weld packs (22% of total)
- ✓ Exceeded 2001 goal of 16.7%
- ✓ 43% of the well line weld packs have been TRT inspected vs. 33% originally planned
- ✓ Goal is to have all well line weld packs TRT'd by 2005
- ✓ Inspection priority - oldest, hottest and thinnest wall lines
- ✓ The % of corroded weld packs dropped from 5% to 1.2% in 2000 and 2001, respectively

2001



# Inspection Results

## External Corrosion



**2002 GOLD**

### Well line External Corrosion Programs:

- ✓ Inspect (TRT) 17% of well line weld packs ~ 4,000 weld packs
  - 2002 YE inspection total to over 14000 weld packs (60% of total)
- ✓ Continue to prioritize older and hotter lines.
- ✓ Continue policy of refurbishing all corroded and heavy wet weld packs.

### Cross County Line Corrosion Programs:

- ✓ Inspect (TRT) 20% of on pad weld packs ~ 1,780 weld packs
  - 2002 YE inspection total to 80% of the total; ahead of the 2004 completion target
- ✓ Continue policy of refurbishing all corroded and heavy wet weld packs.



# Inspection Results

Below Grade Piping

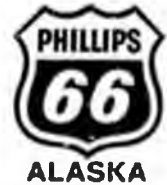

## Doubled Program Work Scope

# 2001

- ✓ **Inspected 228 previously un-inspected locations with PTI/TWI**
  - represents roughly 40% of the population to be inspected
  - approx. half of these locations are regulated “oil” piping
- ✓ **9 cased pipes were excavated (vs. base plan of 4)**
  - 2 had moderate external damage, one was sleeved, one is out-of-service
  - 7 were inspected, with no significant corrosion, and refurbished
- ✓ **10 Refurbishments, 3 Saves, 1 Leak**
- ✓ **Completed Annual visual inspection**
- ✓ **Completed field test of new technology – GUL (Wavemaker)**
  - Evaluation complete, technology not to be adopted



# Inspection Results

Below Grade Pipelining



**2002 Goals**

- ✓ **Complete initial inspection of all significant lines ~ 150 lines**
  - Inspect using PTI and/or TWI technologies
- ✓ **Prioritize and excavate lines as appropriate ~ 5-9 lines**
- ✓ **Work with equipment vendors, Phillips R&D, and BP to improve technology, and explore new technologies**
- ✓ **Test Southwest Research Magneto Strictive System**



# Structural Concerns



## Subsidence Mitigation at the Drill Sites

### **Existing Well Upgrade Program:**

- ✓ **16 floors with riser piping supports were installed in well houses at Drill Site 2M.**
  - Well house floors are supported by the well conductor and provide table riser piping supports.
- ✓ **More than thirty heat tubes were installed at 1A, 1C, 2A, 2K, 2N, 3G.**
  - Heat tubes are used to keep the ground frozen or to re-freeze the ground where it has been thawed.

### **New Wells & Producer to Water Injection Well Conversions:**

- ✓ **New wells had heat tubes, and floors with permanent pipe supports**
- ✓ **Producers converted to water injection wells, and EOR conversions were also upgraded with heat tubes and floors with permanent pipe support**

## Wind Induced Vibration

- ✓ **Identified 4 line segments within design envelope needing dampers – design/procurement in progress**
- ✓ **Engineering is re-evaluating design envelope to ensure validity**
- ✓ **An annual PM is conducted by Engineering and Operations to review all existing PVD installations, and to repair/replace any deficient devices**



# Spills/Incidents



2001

## External Corrosion

- 1HB' VI Water Injection Line Leak, 4/15/01 (Below Grade); previously reported

## Internal Corrosion

- No Leaks in 2001

## Other Structural

- DS 2X Miscible Injectant Line Incident, 12/31/01
  - Through-wall crack, No spill
  - Original weld defect (LF), coupled with WIV was cause
  - Oriented 1 degree outside of PVD Design Envelope

# Spills/Incidents

6" 2A-18 PO Well Line Leak 4/7/02

## Scenario:

- Drill Site Operator discovered oil leaking from the flowline of Well 2A-18, which was immediately shut in
  - The spill occurred sometime between 0430 and 1030 hrs (last walkdown of area done by night operator @ 0430 hrs)
  - Due to the size of the hole, the pressure drop in the line was not enough to alarm or shut in the well
  - Leak area was a pinhole located just above the weld, where a thread-o-let used for Cosasco fitting access was located in a 90° elbow
  - The spill was estimated to be 1200 gallons of product (8% oil and 92% produced water) and covered approximately 1700 ft<sup>2</sup> of the pad
  - The spill was contained on the pad
  - With the C-sands perforations in 1999 the fluid rate in the well increased to 7000 bpd and continue to average 4000 to 6000 bpd.
- ⇒ Cause appears to be flow-assisted corrosion in flow disturbance area





# Spills/Incidents



6" 2A-18 PO Well Line Leak 4/7/02

---

## Background/Inspection History

- Erosion prone areas of this flowline ('S' riser and areas downstream of the choke) have been inspected seven times since 9/20/00. These inspections showed minor damage, but well within acceptable limits
- The last inspection downstream of the choke was done on 3/16/02 and showed minor damage, but was within acceptable limits
- This section of the flow line was thicker walled, 0.863", larger diameter and not where we have historically found erosion/corrosion concerns

## Post-Spill Inspections

- 23% wall loss by UT in the wellhead riser,
- 30% wall loss by RT due to erosion in the 4"x 6" reducer,
- Scattered corrosion pitting in the range of 8% to 15% wall loss throughout the majority of the 6" section of the flowline.
- The manifold piping exhibited erosion to the impingement areas in the range of 4% to 34% wall loss by RT & UT
- A total of 61 locations were inspected by (RT) Radiography and 11 locations by (UT) Ultrasonics.
- No locations on the well line needed to be repaired, other than leak area



# Spills/Incidents

6" 2A-18 PO Well Line Leak 4/7/02



## Incident Investigation Action Items

- Inspect the rest of the 2A-18 flow line prior to putting it back into service  
- **Complete**
- Determine where other similar locations exist at Kuparuk on drill sites  
i.e. thread-o-lets with Cosasco fittings on well lines on the outside  
radius of 90° elbows – **Complete** (Approx. 220 locations)
- Inspect all the locations identified above using radiography to  
determine if there is a pattern of corrosion in these locations.
- Based on the inspection results, develop and implement a long-term  
inspection and repair plan for the identified problem areas.
- All Items to be completed by YE 2002

FALL 2002

MEET &amp; C FOR VII

NOVEMBER 9, 2002

NAME	COMPANY	EMAIL
TIM BIERI	COFFMAN ENGINEERS,	bieri@alaska.coffman.c
RICK FELIX	BP	felix rd @ bp.com
Amanda Leffel	ADEC	amanda_Leffel@envirocon.state.ak.us
KIP SPRAGUE	BP	spragukpc@bp.com
Kirsten Ballard	ADEC	kirsten_ballard@envirocon.state.ak.us
CHRIS DASH	CPAI	LCDASHE@PPCO.COM
STEVE GEDDES	CPA	SGEDDES@ppco.com
Jeanie Yarnell	CPA	jmyarne@ppco.com
Todd Christensen	CPA	tchrist2@ppco.com
Mike Morris	CPA	mmorris3@ppco.com
Jeff Huber	CPA	n1085@ppco.com
Maria Cherry	CPA	n1085@ppco.com
SAM SAENGSUDHAM	ADEC	SAM_SAENGSUDHAM@envirocon.state.ak.us
- Lydia Minor	ADEC	lydia_minor@envirocon.state.ak.us
BOB BRAY	CPA	rdbray@ppco.com
Braed Frates	CPAI	n1462@ppco.com
Randy Brunes	CPAI	N1297@ppco.com
Mike Gahr	CPAI	N1297@ppco.com
Al Dahlquist	CPAI	N1195@ppco.com
MATT COLLINS	CPAI	n1412@ppco.com
MIKE WATTS	COFFMAN	mikebike1@att.net
RICHARD WOOLAM	BP	woolarc@bp.com

BP



*Richard Wallen*

# BP and State of Alaska Charter Agreement

## Corrosion - 2002 Meet and Confer IV

November 4<sup>th</sup> 2002



*GPB*

*Handwritten notes this year to date*



### Outline

- ▶ **Corrosion Monitoring**
  - ▶ 3 Phase production
    - Inhibition
  - ▶ Produced water injection system
  - ▶ Seawater injection system
- ▶ **Inspection Program**
  - ▶ Internal
  - ▶ External
- ▶ **Cased Piping Inspection**
- ▶ **GPB Structural Survey**
- ▶ **Incident Summaries**
- ▶ **Technology**
- ▶ **Summary**

### 3 Phase Corrosion Monitoring

3 Phase Production WLC Corrosion Rates

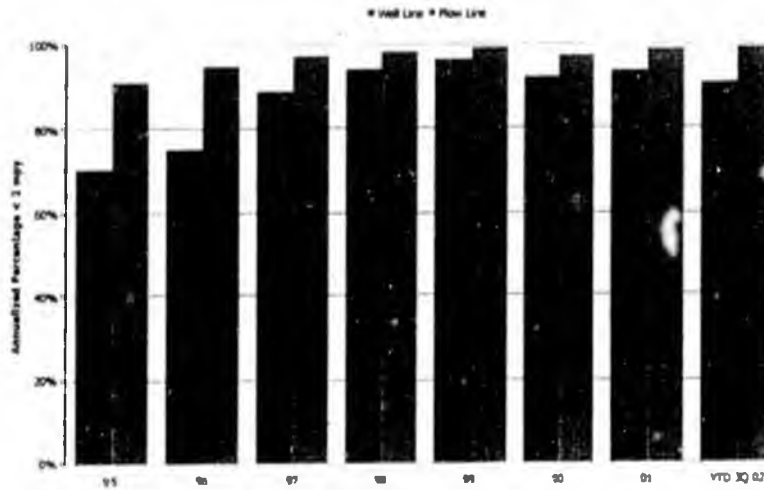

Nov 02

BP/ADEC Meet and Confer IV

3

### PW System Corrosion Monitoring

PW System WLC Corrosion Rates

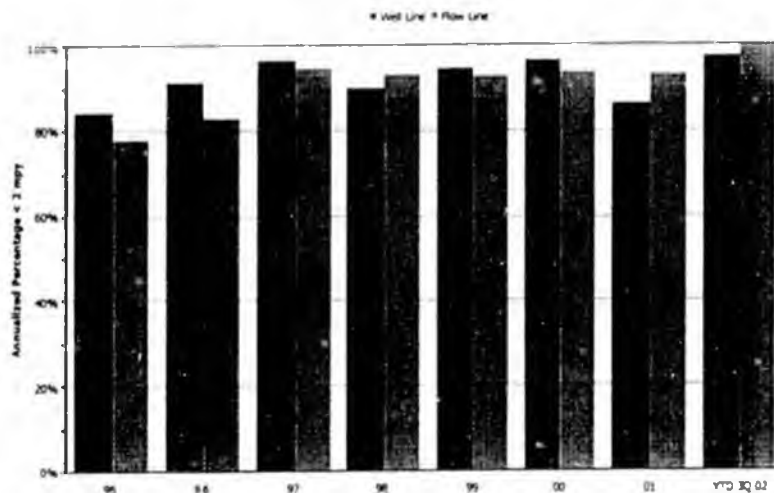

Nov 02

BP/ADEC Meet and Confer IV

4

reflects in Cor Inhib.  
better water sol characteristics



## Corrosion Inhibition

### ► GPB Chemical Changes

- January 2001 :
  - Multiple chemistry across slope
- May 2001
  - Implementation Summer/Winter cross GPB
- October 2001
  - Implemented blending from concentrate
- November 2001
  - Single chemistry - winter version
- January 2002
  - Moved to new chemistry - Partitioning characteristics
    - Improve protection in "W" system and dead legs/drains
- May 2002
  - Summer version, Q1VD120
    - Pour point 0°F
- November 2002
  - Winter version, Q1VD121
    - Pour point -40°F

*Handwritten notes:*

- 40°F pour pt
- 0°F pour pt - 100% methanol
- intensity of acid and acid
- 10% ...
- blend 10/50/50
- methanol
- is needed for concentration

Nov 02

BP/ADEC Meet and Confer IV

5



## Corrosion Inhibition Trends

Corrosion Inhibitor Usage and Concentration

Weekly Ave (gpd) Average ppm GPB Water ppm

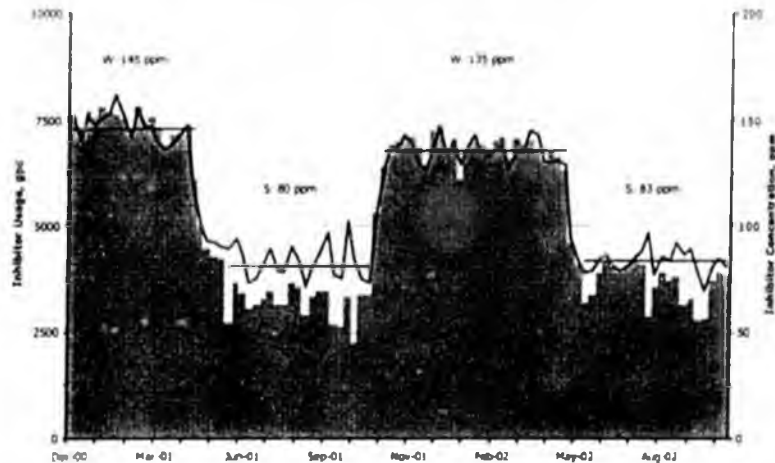

Nov 02

BP/ADEC Meet and Confer IV

6

*Handwritten notes:*

- reduction in water
- rates in summer
- 5 p.p.m. & more than ppm



# 2002 Flow Line Action Log I

## ER Probe Corrective Actions

Equipment ID	Cause	Action
A-74	Calculation adjustment	Added 9 gpd
A-74	Increased Corrosivity	Increase CI by 5%
A-74	Test well under injection	Increase CI by 5%
04B	Increased Corrosivity	Increase CI by 5%
GHX-E	Increased Corrosivity	See Inspection Log
A-74	Increased Corrosivity	Increase CI by 5%

## Coupon Corrective Actions

Equipment ID	Cause	Action
140	Increased Corrosivity	Increase CI by 10%
05D	Inconsistent Batch Treatment	Rescheduled Batch Program
140	Increased Corrosivity	Increase CI by 10%
F44	Increased Corrosivity	Increase CI by 10%
05D	Increased Corrosivity	Increase CI by 20%

*Empty*  
*to appropriate water to make them to be program*

*on last year's log + more*

Nov 02

BP/ADEC Meet and Confer IV

7



# SW System Corrosion Monitoring

SW System WLC Corrosion Rates

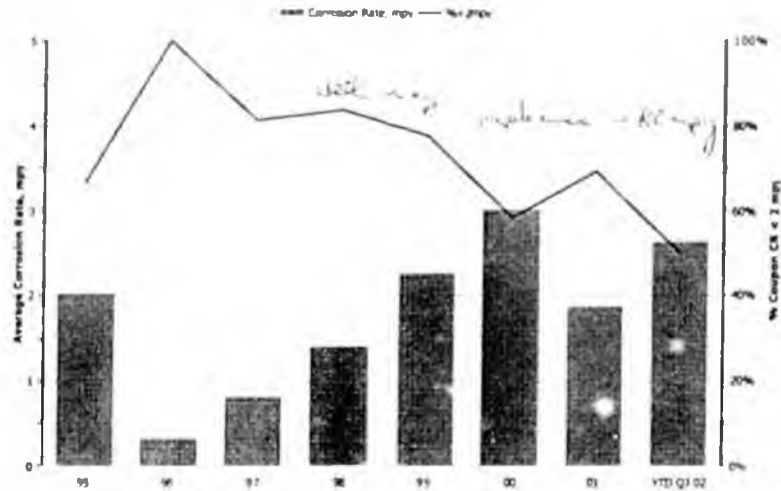

*with a log*  
*impurities - 80 mpy*

Nov 02

BP/ADEC Meet and Confer IV

8

*increase in activity*

## SW System Detailed Analysis



- ▶ **Corrosion Mechanisms**
  - ▶ Oxygen corrosion
  - ▶ Microbiological
- ▶ **Oxygen**
  - ▶ Drives corrosion in upstream
- ▶ **Microbiological**
  - ▶ Drives corrosion in downstream
- ▶ **Oxygen Control Actions**
  - ▶ Set O<sub>2</sub> control < 20 ppb
  - ▶ Mechanical fixes to tower
    - Vacuum pump replace/rebuild
  - ▶ O<sub>2</sub> scavenger
    - Continuous addition
- ▶ **Next Steps**
  - ▶ Microbiological control

	FL	WL	All
1999	9.5	1.4	2.3
2000	7.8	2.6	3.0
2001	1.8	1.9	1.9
2002	0.7	3.3	2.6

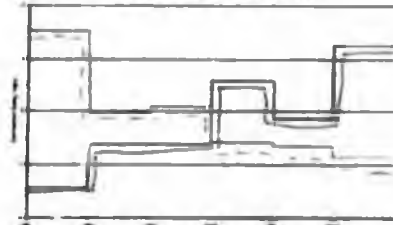

Nov 02

BP/ADEC Meet and Confer IV

9

of taking out O<sub>2</sub> out  
 more O<sub>2</sub> removal  
 due to the  
 corrosion rate  
 due to the

## SW System - Microbiological Corrective Action



- ▶ **Upstream**
  - ▶ Improved Corrosion Control
  - ▶ Improvement dissolved oxygen control
- ▶ **Downstream**
  - ▶ Increasing Corrosion
  - ▶ Attributed to microbiological activity
- ▶ **Microbiological - Corrective Action**
  - ▶ Doubled biocide frequency at mid-year
    - 500 ppm once per week
  - ▶ Supplemental biocide treatments
    - SIP to DS04
      - slug with 500 ppm biocide
    - Entire SW System
      - 4 day soak with 500 ppm biocide
  - ▶ Pigging increased
    - Entire system pigged 3Q 02 - much brush pipe - maint.
  - ▶ **Contributing Factors**
    - ▶ SW system shut downs for STP upgrade for PSI
      - System upgrade for increased seawater rates

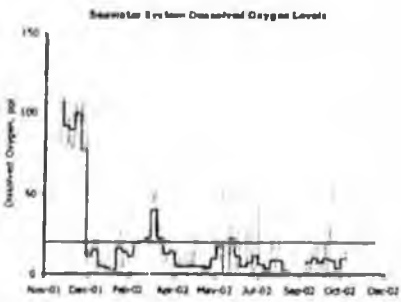

Nov 02

BP/ADEC Meet and Confer IV

10

how doubled  
 and  
 prev  
 250 ppm  
 every other  
 has not been  
 every other

Some parts  
 can be  
 smart for good

XC lines just  
 inactive to see  
 degradation

many lines  
 switch over to  
 local to det  
 cause of drug

one more shut down  
 1 Q 03 - hope to reach '96 levels  
 when plant up to speed  
 hope to see try mid next yr - will make DS

procedure Superior Initiative  
 the thump x 3  
 while system down -  
 untreated

5

## Corrosion Monitoring Summary



			1999	2000	2001	2002
OIL	FL	Ave CR, mpy	0.3	0.4	0.3	0.4
		% < 2 mpy	99%	97%	98%	99%
OIL	WL	Ave CR, mpy	0.5	0.7	0.6	0.7
		% < 2 mpy	96%	92%	93%	91%
PW	FL	Ave CR, mpy	0.5	0.4	0.5	0.2
		% < 2 mpy	93%	94%	93%	100%
PW	WL	Ave CR, mpy	0.6	0.5	2.1	0.3
		% < 2 mpy	95%	97%	86%	97%
SW	FL	Ave CR, mpy	9.4	7.8	1.8	0.7
		% < 2 mpy	0%	0%	100%	100%
SW	WL	Ave CR, mpy	1.4	2.6	1.9	3.3
		% < 2 mpy	88%	64%	67%	33%

### 2001 to 2002 Summary

- ▶▶ 3 Phase (OWG) – Largely unchanged
- ▶▶ Produced water – Performance improved
- ▶▶ SW Systems – Needs improvement

NOV 02

BP/ADEC Meet and Confer IV

11

## Inspection Program – Well Lines



GPB Well Pad/Drill Site Pipelines  
Inspection Measure - Internal Corrosion

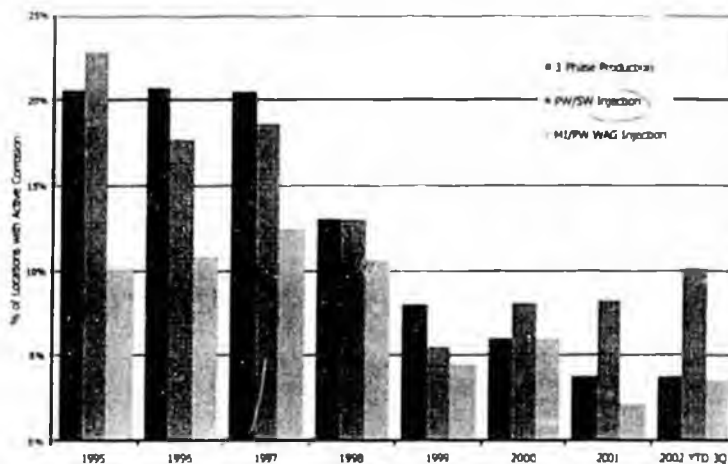

NOV 02

BP/ADEC Meet and Confer IV

12

*sub set of no inspected locations*

*due to impact of SW system*



## Inspection Program – Flow Lines

GPB Cross Country Pipelines  
Inspection Measure - Internal Corrosion

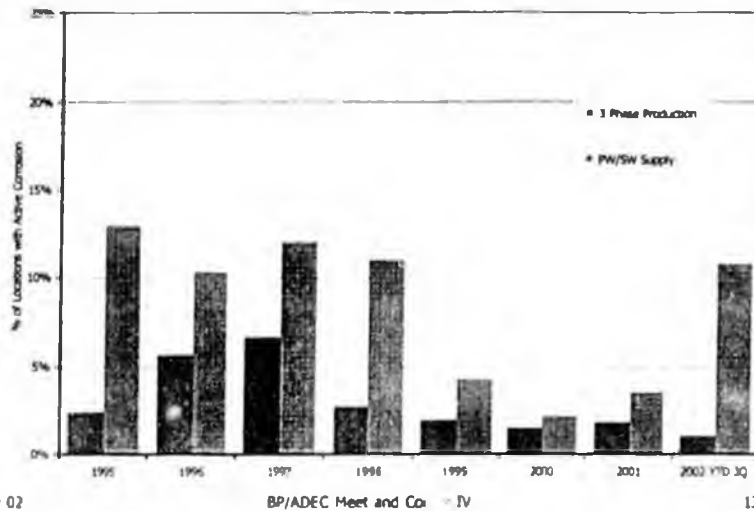

Nov 02

BP/ADEC Meet and Confer IV

13



## 2002 Flow Line Action Log II

### ► Inspection

Equipment ID	Cause	Action
09B	Increased Corrosivity	Increase CI by 10%
H-36	Increased Corrosivity	Increase CI by 10%
GHX-E	Increased Corrosivity	Increase CI by 10%
PW System	Changed Upst team CI	Changed Upstream CI 1Q02
SW System	Biocide rate low	Increased Biocide

Nov 02

BP/ADEC Meet and Confer IV

14

## Smart Pigging Program



### GPB Scope 2002

#### 16" Produced Water Supply

- Flow Station 2 to Drill Site 3  
- Length - 2.9 miles (15,521 ft)
- Flow Station 2 to Drill Site 4  
- Length - 1.3 miles (7,077 ft)
- Flow Station 2 to Drill Site 9  
- Length - 3.2 miles (16,882 ft)

#### Report Status

- Minimal internal corrosion/moderate external corrosion
- Proofing/validation of anomalies scheduled in 2002-03

### ACT Scope 2002

#### 14" Three Phase Production

- K Pad to CFP  
- Length - 4.8 miles (25,175 ft)

#### Report Status

- Minimal external corrosion/Extensive internal corrosion
- Proofing/validation of anomalies in progress

### FFS - Anomalies added to NDE program



Inertial Pipeline Mapping



Triaxial Feature Analysis

Nov 02

BP/ADEC Meet and Confer IV

15

internal corrosion  
fixed everything  
not in for control  
etc

using gloves

update everyone  
they help

Flow

Flow

Flow for  
SUC called  
24,000 gal

## External Inspection Activity



GPB Pipeline TRT Inspection Summary

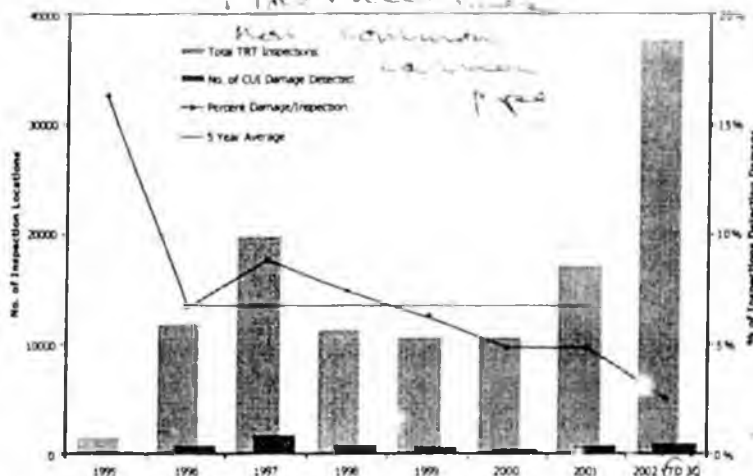

Nov 02

BP/ADEC Meet and Confer IV

16

~25 repairs (guess)

remediated more than  
they repaired - weld/pack  
repairs

3x larger program  
yr

does not meet for 8  
100%

they could  
run pig  
better pig  
Tempa used  
water to cool  
them  
General problem  
thinks elbows  
was water pig

~2.5% damage rate

idea for this season

## GPB Cased Piping



### Inventory

- ▶ Completed field-wide review
- ▶ Established casing index/register

### Location Identification

- ▶ Crossing identified on aerial

### Applicable Technologies

- ▶ Guided wave
  - Switched to magnetostrictive
  - Established permanent monitoring
    - At detected anomalies
- ▶ Electromagnetic wave
  - Ongoing test/evaluation program



### Status

- ▶ 90+% complete with 1 year remaining on 5 year program - all casing crossings

Nov 02

BP/ADEC Meet and Confer IV

17

to a D  
 next  
 given false  
 poss  
 EMI, then guided  
 wave  
 suspected  
 wet locations  
 put in monitoring -  
 metal loss  
 → concern  
 no core analysis  
 on in-line that  
 might be wet

Summer hire project to keep wells out of casing  
 EMI, guided wave - Transient Rad. geometry no  
 longer used

## Cased Piping – Long Range Inspection



### Guided Wave Technology

- ▶ Two concepts for excitation and reception of guided waves
  - Origins differ but concepts are applicable for long range inspection
    - Electromagnetic coupling (e.g. magnetostrictive, EMAT)
    - Piezo-electric coupling (e.g. strain gauge, comb)
- ▶ Comparison of Techniques
  - No significant difference observed between the 2 concepts with respect to false calls and probability of detection
    - GPB Trial November 1993
    - RTD for PRC/AGA August 1999
- ▶ Strategy Shift
  - Permanent/fixing monitoring of magnetostrictive sensors
    - Increase confidence in repeatability tests, reduce false positive
    - Monitor change/growth -vs- isolated evaluation
    - Cost control; single installation, unnecessary excavation

follow up  
 w/ k.p. if  
 more G.S.

Nov 02

BP/ADEC Meet and Confer IV

18



## GPB Structural Survey

### ▶ Field Observation

- ▶▶ Recurring program
- ▶▶ Opportunity program

### ▶ Recurring - Walking Speed Survey

- ▶▶ Five year recurring program
  - 2002 - GPB East Cross Country Pipelines Complete
  - 2003 - GPB West Cross Country Pipelines
  - 2004 - GPB East Well Pads
  - 2005 - GPB West Well Pads
  - 2006 - Lisburne Cross Country Pipelines/Drill Sites
  - Repeat Cycle

### ▶ Opportunity Program

- ▶▶ Security
- ▶▶ Operators

### ▶ FFS

- ▶▶ Anomalies added to ongoing FFS program

Nov 02

BP/ADEC Meet and Confer IV

19



## Kuparuk Flooding

### ▶ Food water behind East channel bridge of Spine Road

- ▶▶ Historically not flooded to the same extent
- ▶▶ Water levels high enough to submerge flow lines between M-pad and GC-2

### ▶ Two 3-bundle lines were the only equipment with observed damage

- ▶▶ Flooding caused the bundles to shift
- ▶▶ Misc. insulation damage/wetting
- ▶▶ One anchor location where each of the bundle lines failed to re-seat properly

### ▶ Actions

- ▶▶ Engineer review
- ▶▶ Insulation & Anchor repair
- ▶▶ CUI inspection scheduled 2003



Anchors not seated



Insulation damage

Nov 02

BP/ADEC Meet and Confer IV

20

600 300 yr flood

## 2002 Leak/Spill Summary



### Leak/Spill Location Summary

	Affected Surface	
	Internal	External
Well Line	2	1
Flow Line	-	1

### Leak/Spill Mechanism Summary

	Mechanism		
	CO <sub>2</sub>	Erosion	CUI
Well Line	1	1	1
Flow Line	-	-	1

### Leak/Spill Fluid Summary

	Service			
	Prod	SW	PW	CUI
Well Line	2	-	-	1
Flow Line	-	-	-	1

Nov 02

BP/ADEC Meet and Confer IV

21

## H-21 S-Riser

### Inspection

- » Prior Inspections
  - 6 locations by Radiography
  - No damage greater than 20%

### Well Head Corrosion Inhibition

- » Normal location + 95% WOA
  - Bleed ring
  - Companion flange
- » 32 exceptions < 5%
  - Continuous CI on S-riser

### System Breakdown

- » Upper elbow risk not recognized
  - Inspection/mitigation program
  - Not synchronized
- » Inhibitor Injection Point not moved

### Corrective Action

- » Short term - complete
  - Inspected 347 GPB s-risers
  - 2 repairs identified
- » Long term - ongoing
  - Move corrosion inhibitor injection locations

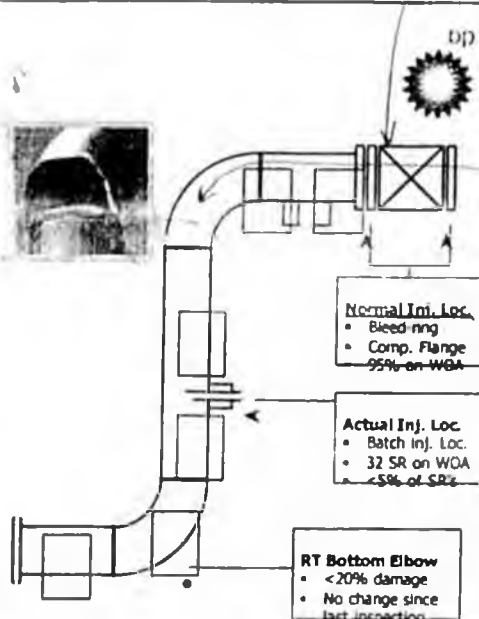

Nov 02

BP/ADEC Meet and Confer IV

22

## 13-12 Well Line



### ▶ Incident Summary

- ▶ May 31st small leak detected
- ▶ Line shut-in and insulation removed

### ▶ Inspection

- ▶ Failure caused by external corrosion
  - Weld pack in saddle
  - 7:00 to 10:00 clock position
  - 8" x 10" network with pinhole leak

### ▶ Corrective Action Plan

- ▶ Complete line review performed
  - All insulation joints
- ▶ Sleeve repair leak location
  - No additional sleeves required



*external*

Nov 02

BP/ADEC Meet and Confer IV

23

## F-48 S-Riser

*300000  
1/2 hrs  
occurred in 10 min*



### ▶ Incident Summary

- ▶ Erosion by produced solids
  - Hard-line from F-39 to F-48

### ▶ Corrective Action Plan

- ▶ Inspection of adjacent piping
- ▶ Long term
  - Identify similar locations
  - Integrate into O&M program
- ▶ Interface with Operations

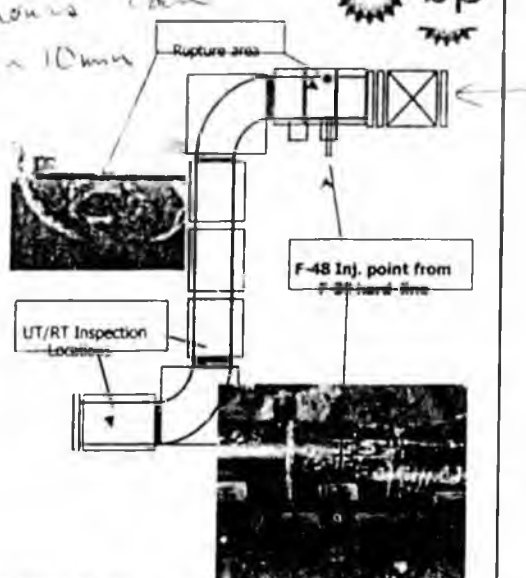

Nov 02

BP/ADEC Meet and Confer IV

24

## Z Pad Large Diameter Flowline



- ▶ **Incident Summary**
  - ▶ October 4th a small leak detected
  - ▶ Line shut-in and insulation removed
- ▶ **Inspection**
  - ▶ A breach found in insulation at low point drain
  - ▶ Failure caused by external corrosion
  - ▶ Corrosion network present 360°
    - Leak at 12:00 o'clock position
- ▶ **Corrective Action Plan**
  - ▶ Inspect adjacent piping
  - ▶ Sleeve repair leak location



Rupture area before insulation removal



Rupture area

Nov 02

BP/ADEC Meet and Confer IV

25

*leak was not properly sealed.*

*pinhole leak*

## Technologies for Corrosion and Integrity Management



*helped of data bank + exp data*

- ▶ **PDT/MIMIR**
  - Paperless environment
  - Improved access to data
    - Electronic versus paper copy
- ▶ **Remote Access Technology (RAT)**
  - Alternative to access via scaffolding
  - Use of ropes to access equipment and piping
- ▶ **Remote Operated Vehicle (ROV)**
  - Inspection of firewater and raw/potable water tanks
  - Used for sediment removal
  - Capable of performing visual and UT inspections
- ▶ **Digital Radiography (DRT)**
  - 100% use of technology by CIC across BPX assets
  - Reduced HSE risks
    - chemicals, radiation exposure
  - Multi-location access to images



Nov 02

BP/ADEC Meet and Confer IV

26



## Summary

### ▶ Internal Corrosion

- ▶ 3 Phase production – largely unchanged
- ▶ Produced water - improving
- ▶ Seawater
  - Oxygen control - dramatically improved
  - Microbiological control – biocide dosage increased

### ▶ External Corrosion

- ▶ YTD approximately 3 times historical average *inspection*

### ▶ Incident Summary

- ▶ YTD 50% internal/50% external

### ▶ Cased Piping

- ▶ In year 4 90+% complete of 5 year program

### ▶ Technology

*improvements - trying new*

CPA

309, 30, 50 B



# Greater Kuparuk Area

## Commitment To Corrosion Monitoring Overview

presented to the

Alaska Department of Environmental Conservation

*4<sup>th</sup> Meet & Confer*

November 4, 2002



# Inspection Results

Internal Corrosion



## Cross Country Lines

Corrosion Is Under Control

- ✓ Exceeded RTR goal of matching 2001 footage
- ✓ Over 30,000 ft of over 233 lines inspected (RTR and RT) through 9/30
- ✓ Integrated Turbulent Area Inspection Program
- ✓ 0 Leaks, 0 Saves through 9/30
- ✓ Smart pig of water lines >10" appears feasible – evaluation ongoing

2002 YTD

### Internal Corrosion Spills - Cross Country Lines

1994 Spill 24" 1Y/R Crude CC Line

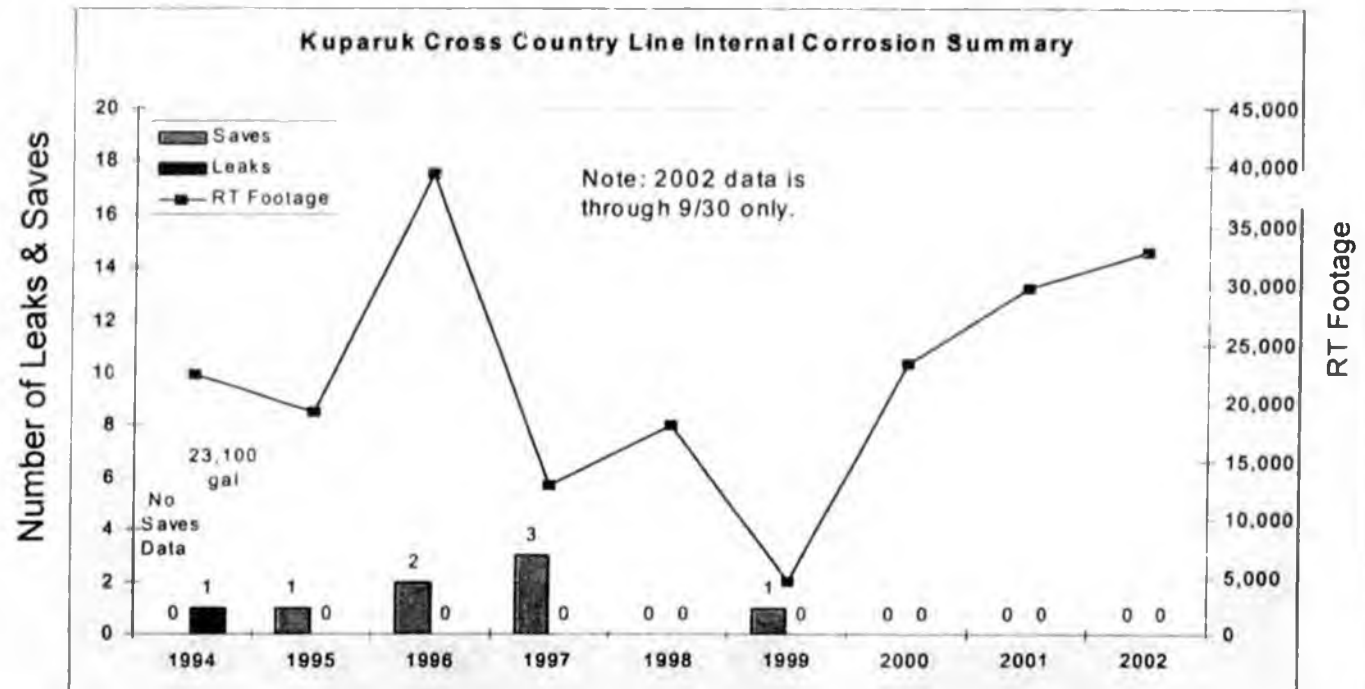

### Well Lines

#### Internal Inspection Focus Area

2002 YTD

On schedule with 2002 goal to complete all .312" lines.

- ✓ Over 12,000 ft of over 448 lines inspected (RTR and RT) through 9/30
- ✓ 12 lines required repair through 9/30 (4 injectors, 8 producers)
- ✓ 2 Leaks, 10 Saves through 9/30
- ✓ Pursuing expanded inspection scope @ DS 2T

#### Internal Corrosion Spills – Well Lines

38 Spills	1L-1 6" WI
	1L-3 6" WI
	1A-9 6" WI
2000 Spill	1G-8 6" PC
2002 Spills	2A-18 6" PC
	2T-13 6" PC

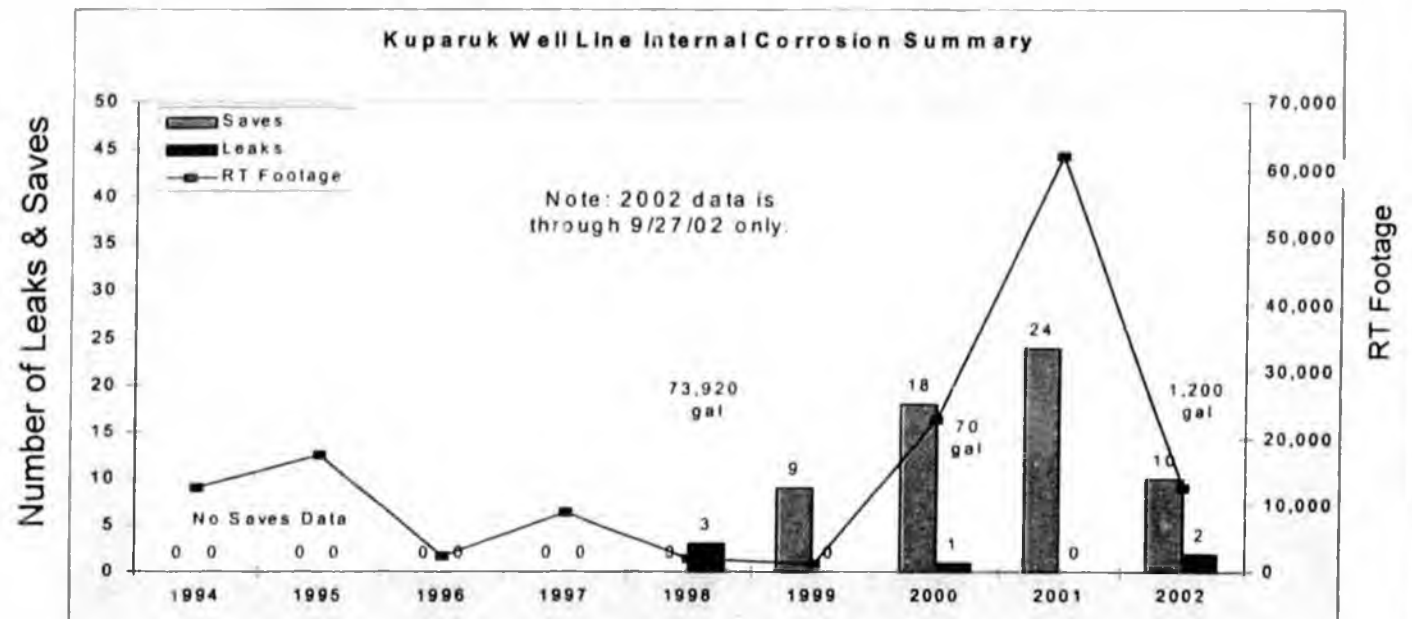



# Inspection Results

Internal Corrosion



2A-18 anomalies -  
2T-13 This is wall pitting thickness

- ✓ **Continue to Focus on and Inspect Well Lines**
  - Inspect next 100 highest priority well lines.
  - Priority based on wall thickness, age of line, and time since previous inspection
  
- ✓ **Maintain Inspection of Cross Country Lines**
  - Inspect roughly 15,000 feet by RTR *1/2 mil - much on 100 ft*
  - Complete backlog of "Turbulent Area Program" inspections (formerly called "Elbow Inspection Program")



# Monitoring/Mitigation

ConocoPhillips

## Results & Accomplishments

YTD 2002

### Monitoring:

- ✓ In the 3-phase production system, coupon general and pitting rate averages remain under threshold limits and are trending down
- ✓ Over 90% of 3-Phase Production CC lines with ER probe rates < 2 mpy
- ✓ Corrosion rates on the water injection well line coupons have decreased
- ✓ Corrosion rates on the wet oil cross country line coupons have decreased markedly

### Mitigation:

- ✓ Inspection data shows corrosion is under control in the cross country lines
- ✓ All inhibited 3-Phase Production CC lines with probe, coupon, or inspection rates above thresholds had corrective action taken (inhibitor rates were increased during 1<sup>st</sup> half 2002 opt cycle) \* excluding test DS1R, which was pulled after opt cycle and was 'A' grade  
*optimization cycle*
- ✓ Continuous wellhead injection system installed and operating at DS1G
  - Additional Drill Sites installations funded; construction to start this winter



# Monitoring/Mitigation Three-Phase Cross Country Lines



## Summary YTD 2002

*Bill calls them  
flow lines*

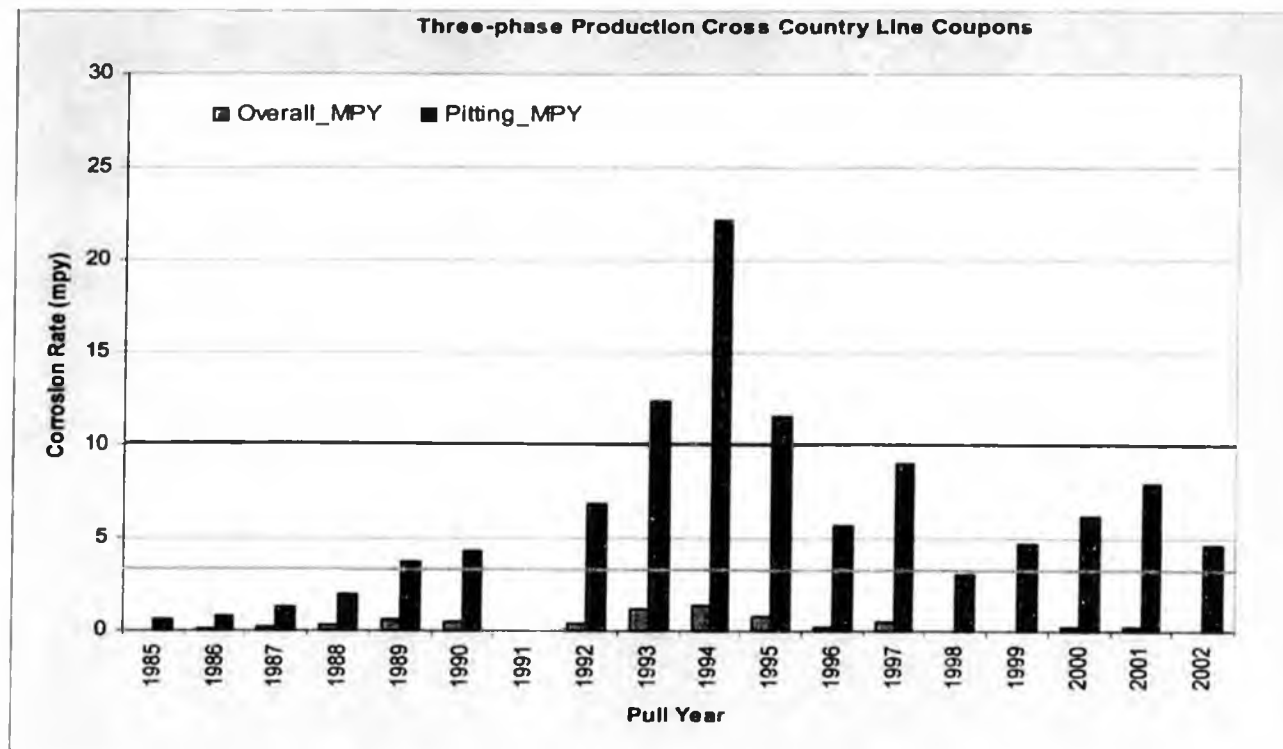

- ✓ Coupon average corrosion rates in the 3-phase production lines have improved due to optimization cycles and perhaps change to RU276
- ✓ Coupon corrosion rates are a conservative measure, and are an advance indicator
- ✓ Inspection data shows corrosion is under control in the 3-phase CC lines
  - Less than 5% of repeat inspection locations showed increases

*See record to news 1  
w/ M. 2/1/02*

*< .5 mil pt no show on 117*

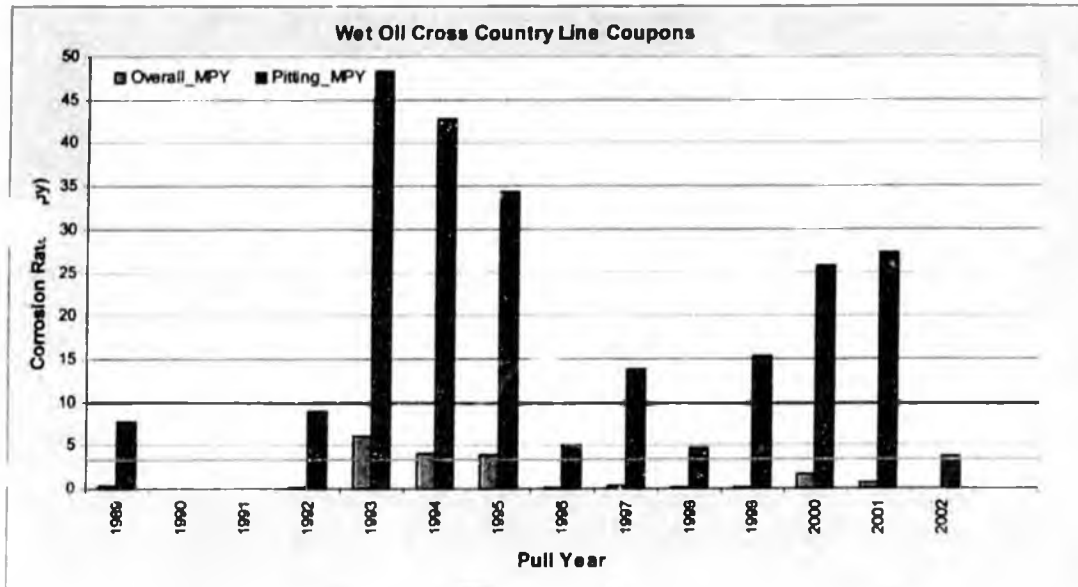

⇐⇐ Wet Oil CC Lines:

- ✓ Wet oil lines coupon corrosion rates have decreased markedly
- ✓ 24" wet oil line removed from service in 2001 *low velocity*
- ✓ 16" and 12" wet oil lines coupon corrosion rates are lower – more effective inhibition

Water Injection Well Lines: ⇒⇒

- ✓ Coupon corrosion rates have decreased slightly YTD
- ✓ Past upward trend is currently reversing

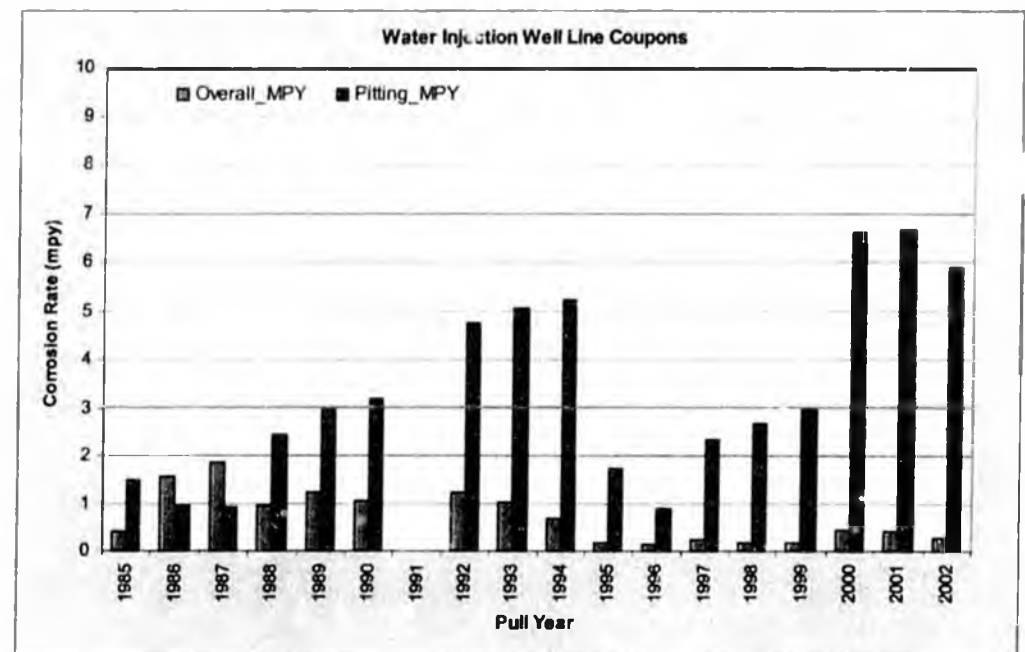

# Summary

## YTD 2002

*in survey avg*

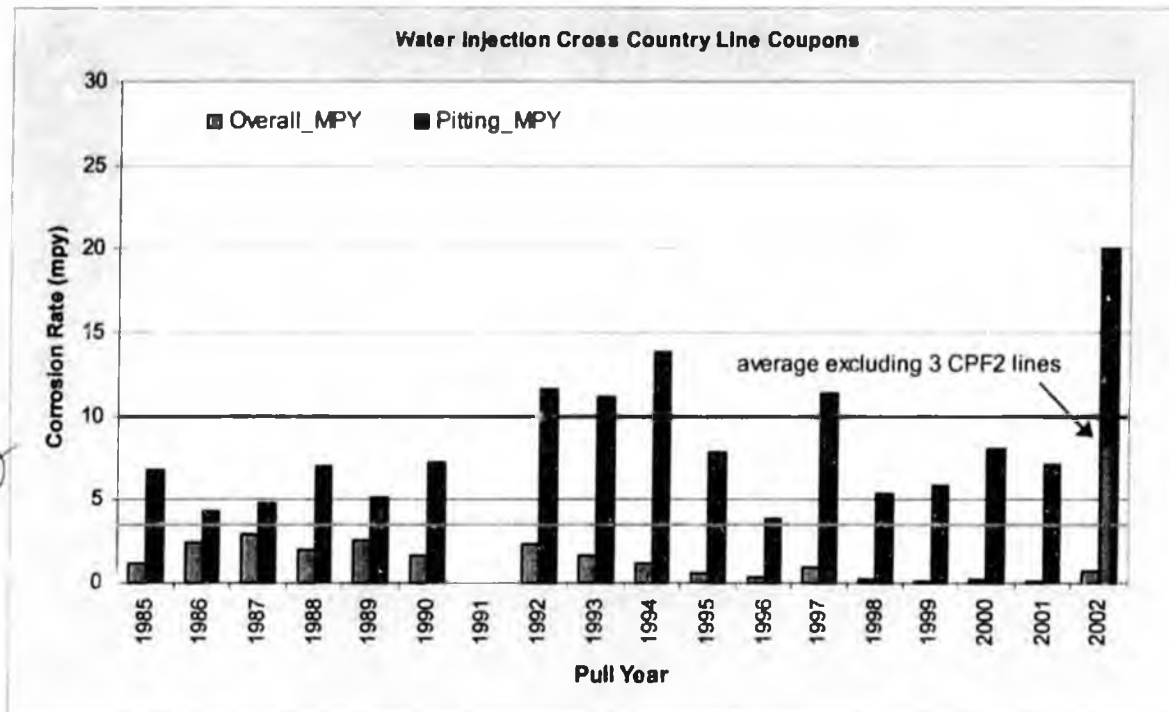

*CPF2 lines  
all @  
facility  
unpassable  
6-10-02  
100-100  
-103*

### Area of Concern

- ✓ Coupon average corrosion rates in the water injection cc lines have increased
- ✓ Average affected mainly by a 3 lines at CPF2. Field average pitting rate excluding "bad actors" falls below threshold.
- ✓ Recent inspection data from the 3 CPF2 lines shows only minor damage (worst case B grade)
- ✓ Nevertheless, work is underway to find the cause

*Ru270 used in 1999  
in lower concentrations*

*TRCO → PA1 is - manufactured  
API 570 regime, nearby*

## 2002 Goals Update

✓ **Find more effective corrosion inhibitors**

- Implemented RU-276 field-wide in first quarter of 2002
- Previous upward trend in coupon rates appears to have turned
- Field test completed at DS1R yielded good quality data
- New lab screening process implemented with good results

✓ **Implement wellhead continuous injection**

- New system is pumping corrosion inhibitor at DS1G well head locations.
- Technology evaluation in progress (automated system)
- Starting construction this winter at additional drill sites.

✓ **Schmoo B Gone Test Update**

- Capital project funded and in design stage.

*- poss. mit. injection  
for low-flow areas to keep  
solids from building*



# Inspection Results

External Corrosion

ConocoPhillips

## 2002 YTD Summary

Historical GKA External Leaks and Saves

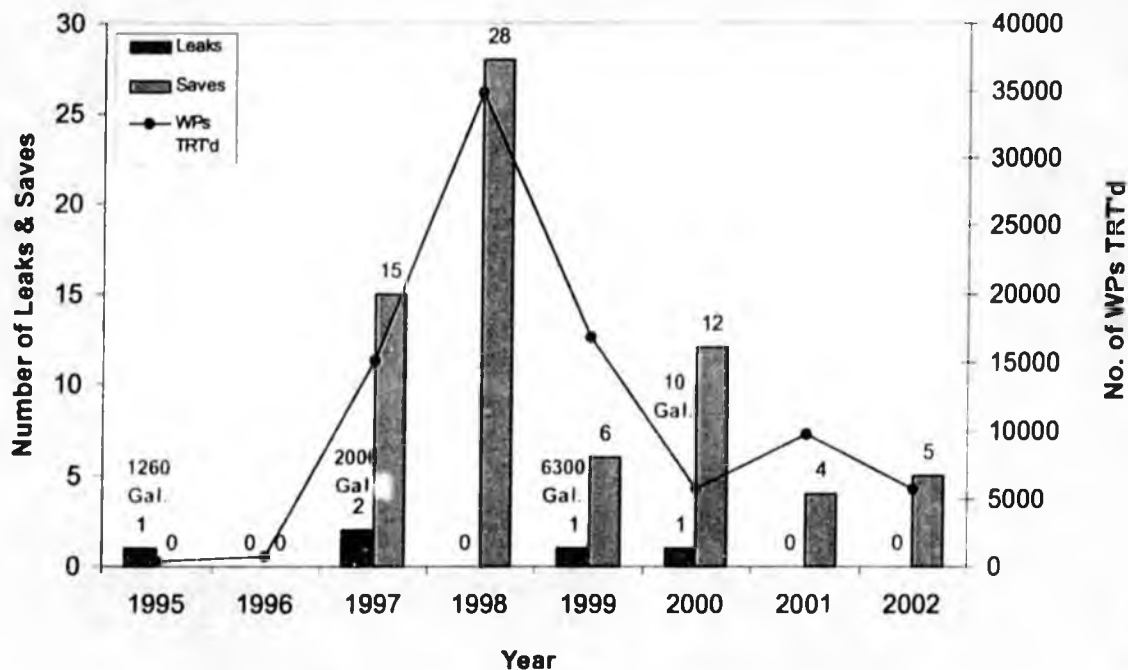

ABU GRADE

### External Corrosion Line Failure History

- 1995 2C-04 Well Line
- 1997 2 ea. 24" Crude CC Lines (Weld Pack @ Saddle)
- 1999 1A-15 Well Line (Weld Pack @Saddle)
- 2000 2X-16 Well Line



# Inspection Results

CC Lines External Corrosion

ConocoPhillips

## CC Lines Over Tundra:

- ✓ Initial TRT inspection of over-tundra CC weld packs and refurbishment of heavy wet and corroded weld packs was completed by YE 2001. Final walk down verifications are underway.

Began initial recur effort in 2002, targeted medium-wet weld packs in saddles from initial survey

- ✓ Increase in %-Corroded was expected due to target population

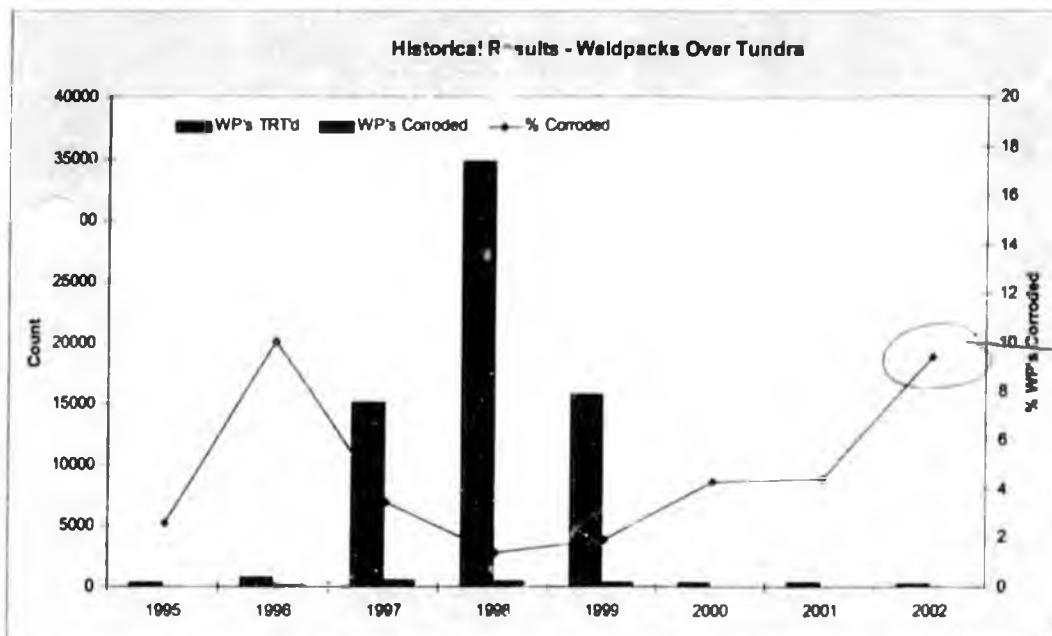

*near cycle 7003 - should move to a more even cycle ~ 5000/yr*

## CC Lines On Pad: ⇒⇒

- ✓ TRT'd 2542 on-pad cross country weld packs YTD, exceeding 2002 FY goal of 1780
- ✓ 91% of on pad cross-country line weld packs have been TRT'd to-date
- ✓ The % corroded weld packs found has dropped slightly, ~ 1.8%

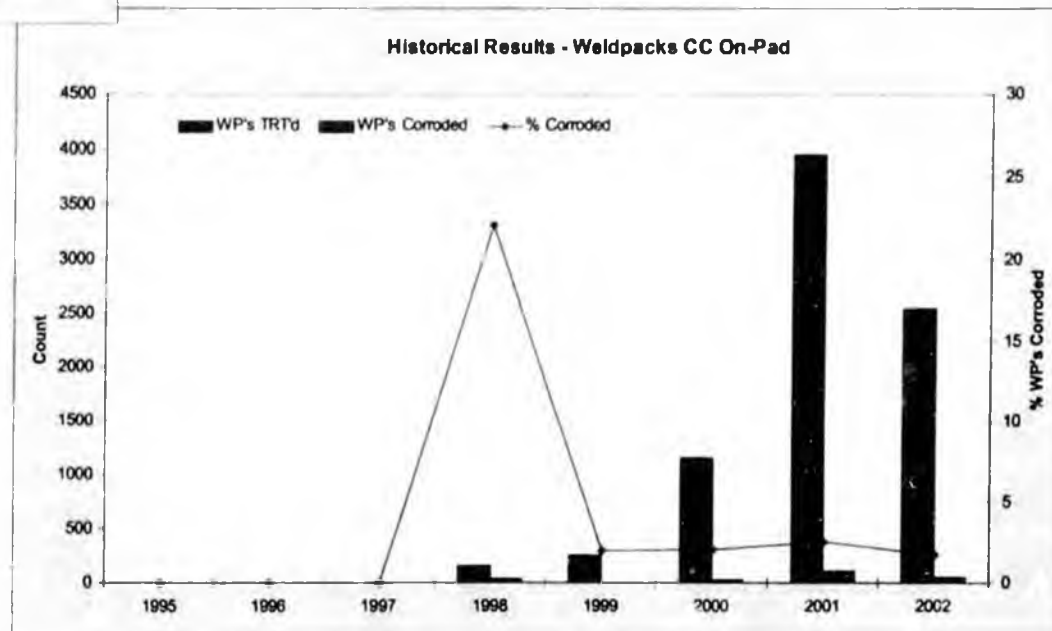



# Inspection Results

## Well Lines External Corrosion

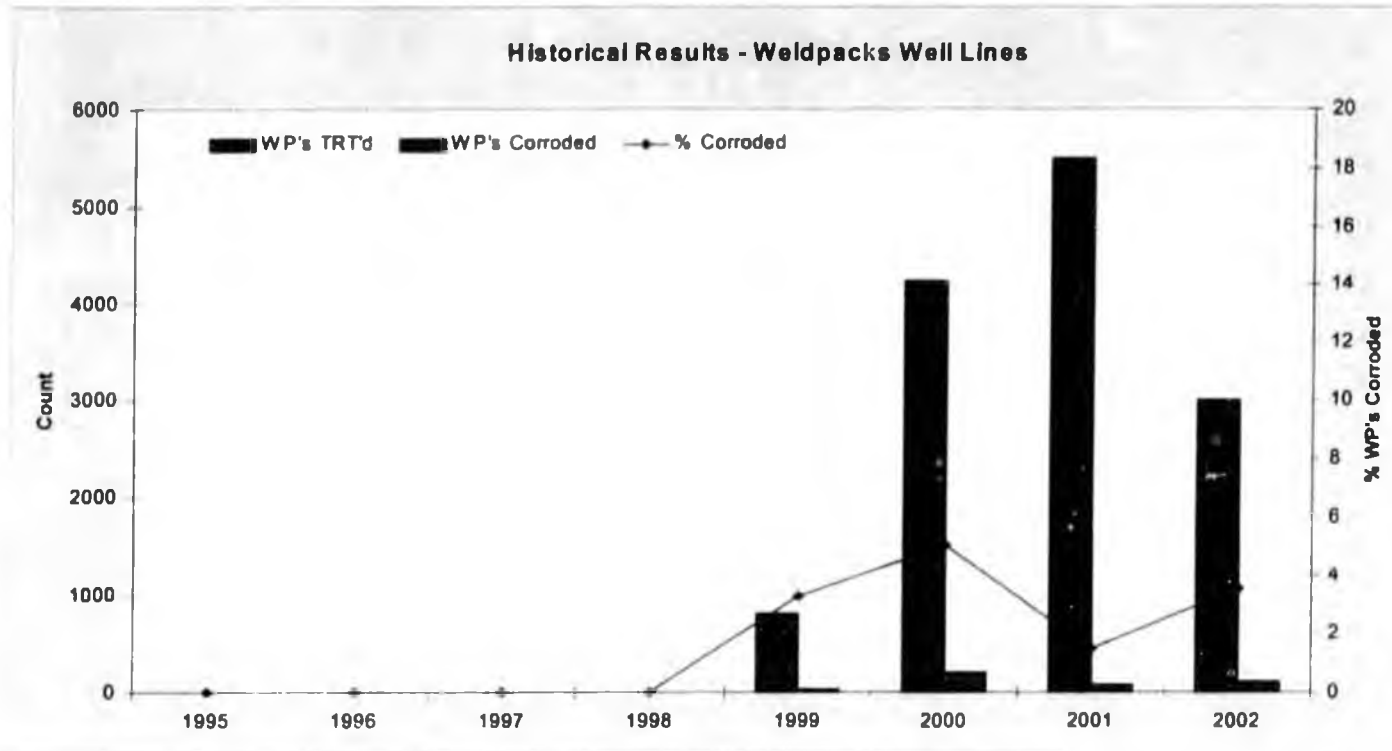

### Well Lines :

- ✓ TRT'd 3007 well line weld packs YTD
- ✓ On-track to reach 2002 goal of 4000 weld packs TRT'd *now met*
- ✓ 55% of the well line weld packs have been TRT'd YTD
- ✓ Goal is to complete well line weld pack TRT baseline inspections by YE 2005
- ✓ Continue to monitor %-corroded and respond to trends

2002



# Inspection Results

Below Grade Piping



*Cased Pipe*

2002 YTD

## Met Goal of Inspecting All Priority 1 Pipes

*used to be category 1-2-3*

- ✓ Inspected all 130 previously un-inspected priority 1 locations with PTI/TWI
- ✓ 8 cased pipes were excavated (goal was 5 to 9)
  - 2 had severe to moderate damage (1 internal, 1 external).
  - The external damage was sleeved, the internal damage was replaced/upgraded
  - 6 had minor or no significant corrosion
- ✓ 8 Refurbishments, 2 Saves, No Leaks
- ✓ Completed Annual Visual Casing Inspection; cleared all obstructions
- ✓ Will share BP's evaluation of Magneto Strictive technology from B&E

*EM general issues  
(conductance issues)*

*inconclusive / incomplete results → patch or replacement*

# Inspection Results

Below Grade Piping



2003 Goals

- ✓ **Re-inspect roughly 60 priority 1 pipes**
  - Inspect using PTI and/or TWI technologies
- ✓ **Complete initial inspection of all priority 2 lines ~ 115 lines**
  - Mostly atmospheric/low pressure flare/gas lines - Inspect by visual inspection and “sniff” for gas
  - Selectively use PTI and/or TWI technologies where warranted
- ✓ **Prioritize and excavate lines as appropriate ~ 5-9 lines**
- ✓ **Work with equipment vendors, Phillips R&D, and BP to improve technology, and explore new technologies**



# Inspection Results

## Below Grade Piping

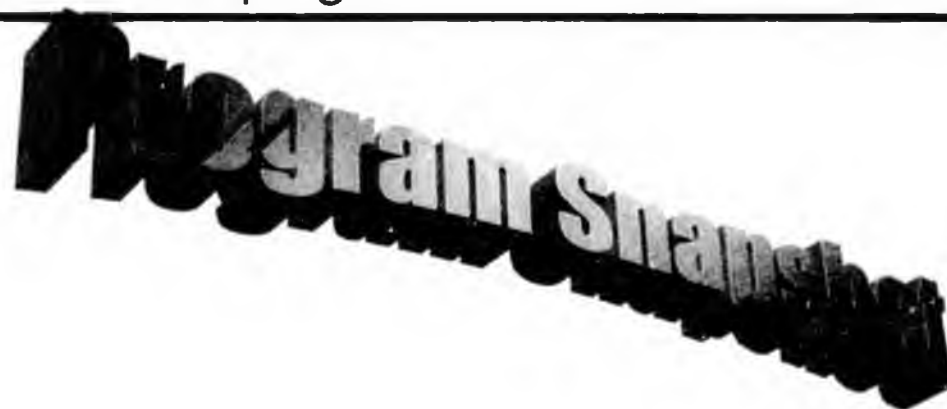

Note: The only uninspected priority 1 lines are those that are newer than 10 years old

All Lines in GKA/AOA Inventory	Inspected Thru 10/31/02	Un-inspected Lines	Total	Previously Uninspected Lines Inspected in 2002
Priority 1 Oil	331	44	375	38
Priority 1 Non-Oil	225	17	243	92
Priority 2 Oil	1	18	19	0
Priority 2 Non-Oil	0	98	98	0
Priority 3 Oil	1	21	22	0
Priority 3 lines Non-Oil	2	13	15	0
<b>2002 Total Inventory</b>	<b>561</b>	<b>211</b>	<b>772</b>	<b>130</b>

## Subsidence Mitigation at the Drill Sites

### Existing Well Upgrade Program - 2002:

- ✓ Installed approximately 53 floors with pipe supports
  - Drill Sites 1A, 1D, 2T, 3F, 3O, and 3Q
- ✓ Installation of approximately 23 heat tubes in progress at Drill Sites 1D & 1R
  - Heat tubes are used to keep the ground frozen or to re-freeze the ground where it has been thawed
- ✓ Installation of permanent fixed pipe supports in progress at Drill Sites 2K & 2M

*well head shelter floor  
safe working platform for operations*

### New Wells & Producer to Water Injection Well Conversions:

- ✓ New wells had heat tubes, and floors with permanent pipe supports
- ✓ Producers converted to water injection wells, and EOR conversions were also upgraded with heat tubes and floors with permanent pipe support (approximately 15 heat tubes)

### Effectiveness/Monitoring

- ✓ Periodic subsurface thermistor monitoring indicates the heat tubes are achieving the desired results, showing the expected thaw bulb contraction

## Subsidence Mitigation at Drill Site 2M

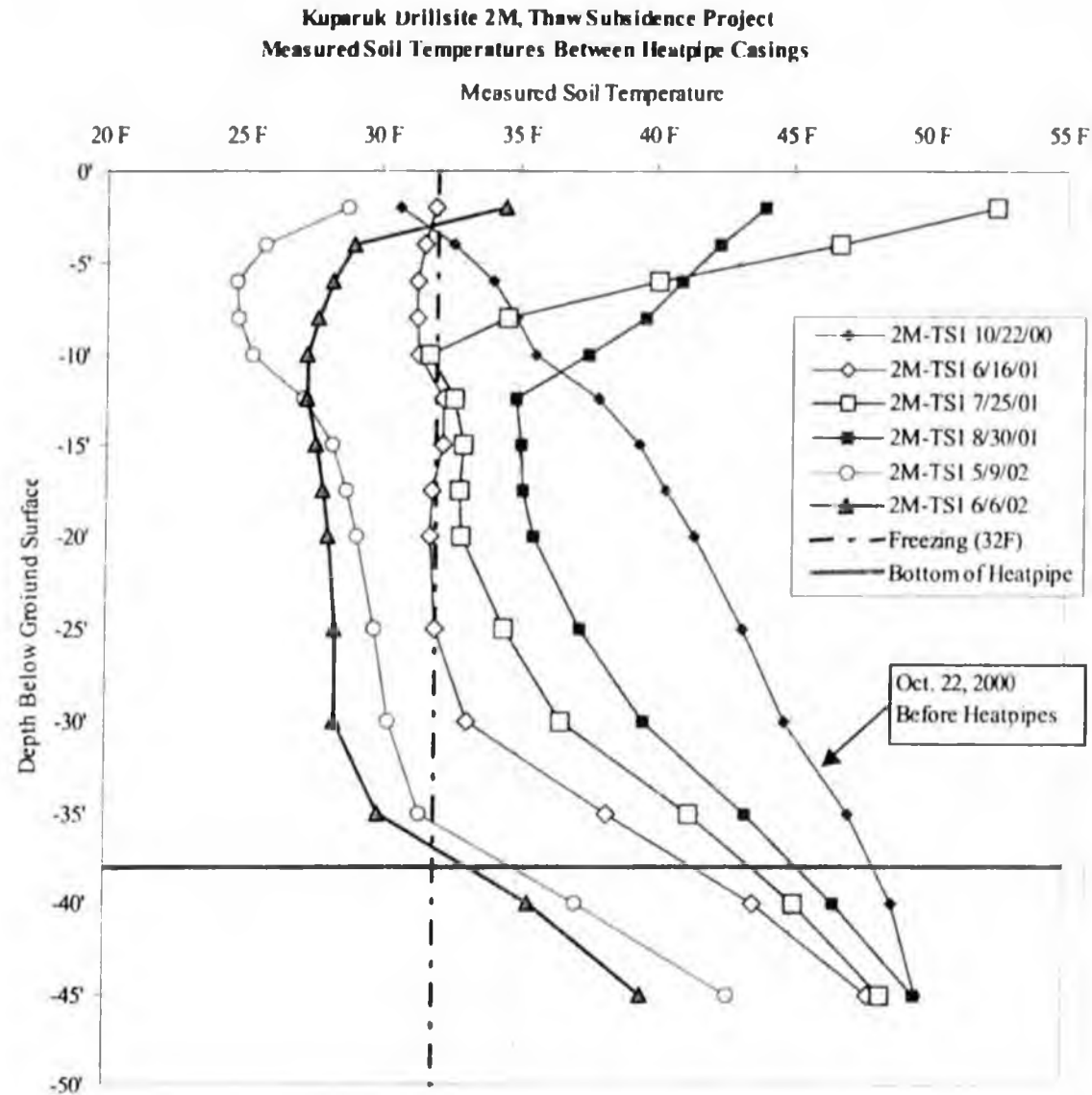

## Wind Induced Vibration

- ✓ Progressive improvement since program inception - 1991
  - PVD elastomer improvements (Generation I, II, III & IV elastomers) - *seal to degrade*
  - TVA development *active v. vibration dampener*
    - Eliminates elastomer problems - *shielded from elements*
    - Decreases maintenance
    - Decreases device failure frequency
    - Increases system performance
- ✓ Annual PM conducted by Engineering & Operations to review all existing PVD/TVA installations and to repair/replace any deficient devices
- ✓ WIV study on 12" and 14" Alpine Pipelines (November 2000 – November 2001)
  - Existing WIV Mitigation Program performs as designed
  - Design wind fan criteria valid (N45°W-N30°E) *paper & field wedge use TVA/PVDs*
- ✓ NO failures attributed to pipelines employing PVD/TVA devices since program inception *place*
  - 2X failure in January, 2002 (small LOF in weld root) *Small low displacement passing by what was*
    - 1° outside wind fan design criteria *(= 10% of design)*
    - No PVD/TVA devices installed prior to failure

## Wind Induced Vibration

- ✓ Identified 6 cross-country pipeline routes within design envelope requiring PVD/TVA devices
  - Design/installation in progress
  - DS3N to be monitored – falls directly on N45°W periphery of design envelope
- ✓ PVD/TVA installation effectively remediates initiation and/or propagation of any indications or defects
  - Vibration P-P amplitude limited
  - Stress range limited
- ✓ Quantitative & Qualitative Assessment
  - TRT, VT – (435 weld pack locations – 70 locations w/ C-rank & D-rank damage)
  - UT – (22 locations – 1 locations w/ C-rank damage)
  - RTR – (Aggregate total of 10,892 ft – 11% worst-case wall loss)
  - Exhaustive NDE techniques during construction
  - Tough, ductile materials (Specifications, CVN, CTOD, hardness, etc.) *Co. Specs for -50° requirements - goes beyond wall*
  - Continuous improvement of PVD/TVA system performance
  - Regardless of pipe wall damage mechanism, no failures have occurred since program inception validating the remediation effectiveness of PVD/TVA installations

2002

## External Corrosion

- No incidents to report

## Internal Corrosion

- 2A-18 Well Line Leak at Cosasco Fitting/Elbow (4/7/02); previously reported
- 2T-13 Well Line Leak (7/25/02)

## Other Structural

- No incidents to report

# Spills/Incidents

6" 2A-18 PO Well Line Leak

4/7/02

ConocoPhillips

## Scenario:

- Leak area was a pinhole located just above the weld, where a thread-o-let used for Cosasco fitting access was located in a 90° elbow
- 1200 gallons of product (8% oil and 92% produced water) on-pad
- ⇒ Cause appeared to be flow-assisted corrosion in flow disturbance area



## All Action Items Complete:

- ✓ Inspected remainder of 2A-18 well line prior to returning to service
  - Post-spill inspection of well line showed no areas required repair, other than leak location
- ✓ Completed survey for similar locations at all Drill Sites (283 locations)
- ✓ Completed RT inspections on all 283 similar locations on 6/22/02
  - No repairs required due to this corrosion mechanism
  - Two repairs due to other causes (questionable original weld, deteriorated threads)
- ⇒ Inspections confirm theory of isolated mechanism
- ✓ Added these locations to recurring interval survey for each well line

*2000 ft of pipe  
had been in numerous  
service types - do not think  
there is benefit in making surveys  
for rep interval determinations*

# Spills/Incidents

6" 2T-13 PO Well Line Leak

7/25/02

ConocoPhillips

## Scenario:

- Leak occurred shortly after shutting-in well at manifold building
- Leak was isolated within 5 minutes by closing wing valve at wellhead
- 10 gallons of product (41% oil and 59% produced water) spilled, contained on-pad
- Leak occurred in 0.375" wall thickness section of line at a weld pack
- Completion of investigation delayed due to lack of access

*as determined at 2 weeks ago*

## Background/Inspection History:

- Pre-spill inspections on this line consisted of:
  - weld-packs
  - branch connections (part of 2A-18 follow-up inspections)
- Piping was originally installed at DS 3R, then reclaimed for use at 2T-13 in 1996
  - Pipe was new when installed and abandoned at DS 3.
  - Condition of pipe when installed at 2T-13 in 1996 is unknown
- Based on age (6 years) and wall thickness of 0.375", this section was not scheduled for initial internal inspection until 2004.

*don't know if hydrotested  
@ 3R was Hydrotested  
@ 2T*



# Spills/Incidents

6" 2T-13 PO Well Line Leak

7/25/02 ConocoPhillips

## Post-Spill Inspections:

- Post-spill inspections initially limited to accessible areas:
  - Showed substantial, but non-derating damage on 0.312" wt section
  - Showed only minor (<20%) damage in accessible 0.375" wt section
- Access finally allows completion of inspections (October 2002):
  - Showed cause to be severe internal under-deposit corrosion, evident throughout the 0.375" wt section
  - Low fluid velocity is causal factor (???)

*diff Reservoir*

## Action Plan:

- Evaluate replacement line size for well 2T-13 to minimize under deposit corrosion when well is placed back into service - **Complete** (4" piping will be used)
- Inspect all well lines at DS 2T for internal corrosion, to determine if similar conditions exist
- Based on inspection results, determine if inspection criteria across field should be modified
- Target completion March 2003

*not just 0.312"*

*rechemical or other 3R lines  
 re configuration pipe - also need @ 2T  
 must det FFS in place -  
 11/4/02 when*

- **CUI Buffer Spikes installed at 76 test locations in fall 2002**
- **Initial pH readings found at 6 to 7 pH** *- Baseline*
- **Follow-up pH testing and evaluation scheduled for summer 2003**

*Test for diffusion*

## Buffer spike:

stick of sodium phosphate (a buffer salt)

Dissolve into weld pack moisture

Create an environment with a stable pH of about 10 (basic):

*capillary action*

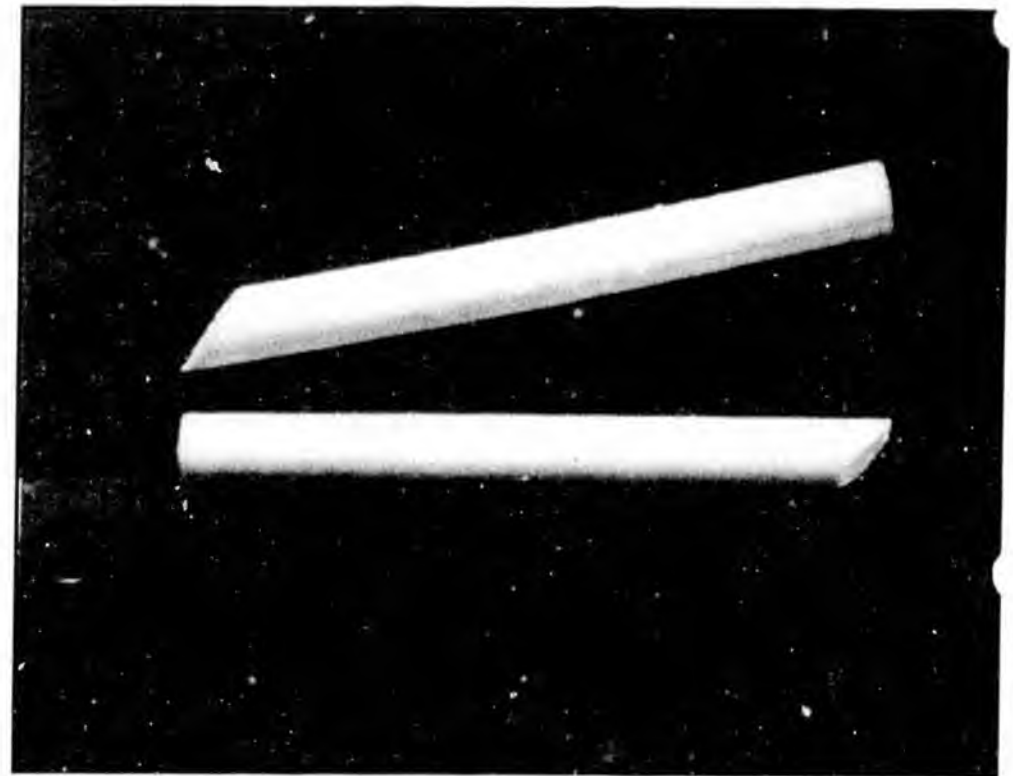

Steel corrosion rates decrease as pH increases  
(Alkaline solutions slow corrosion)

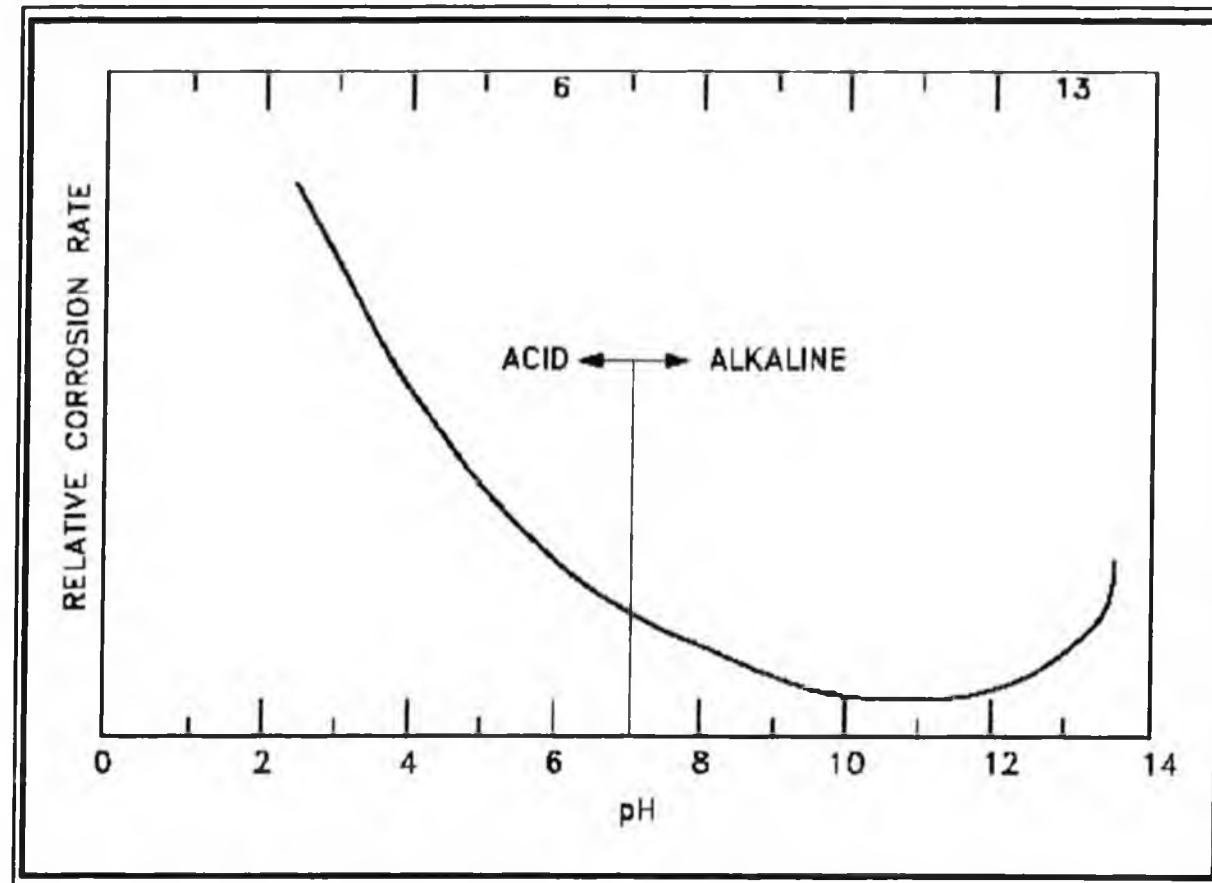

SPRING 2003

4/28/03

# ADEC MEET & CONFERENCE

<u>NAME/TITLE</u>	<u>COMPANY</u>	<u>PHONE/EMAIL</u>
FELIX / CORR ENGR	BP	564-4466 / felixrd@bp.com
KIP SPRAGUE / INT. ANALYST	BP	564-4462 / spraguokp@bp.com
RICHARD C WOOLAM / CIC MANAGER	BP	564-4437 / woollarc@bp.com
MIKE SCRIBNER / Prod Assurance	COP	918-661-0400 / mikes.scribner@conocophillips.com
DAVID BLUNTER / Prod Assurance	COP	918-661-5414 / david.blunter@conocophillips.com
JEFF HUBER / CPF3 Prod. Sup	CPAI	659-7682 / n1175@conocophillips.com
BOB BRAY / O&A OPERATIONS SUPPORT MGR	CPAI	659-7289 / rdbray@poco.com
CHRIS DASH / CORROSION ENGINEER	CPAI	263-4878 / Chris.Dash@conocophillips.com
KRISTIN FROST / CORROSION	CPAI	550-... / n1462@conocophillips.com
EL GOLDMANN / CORR ENGR	CPAI	659-7149 / n1462@conocophillips.com
KU ZHANG / CORR ENGR	BP&A	564-4449 / kuzhang@bp.com
RANDY HEALD / Director of Process Analysis	ConocoPhillips	918-661-3156 / Randy.L.Heald@conocophillips.com
MIKE GAHR / CORR ENGR	CPAI	907-659-7869 n1297@conoco
TOM DEKUYTER / Environmental Specialist	ADEC	451-2145 Tom.Dekuyter@DEC.state.ak.us
MICHAEL WATTS / CORROSION ENG	1ST PRIN	310-367-8632 / MIKEBIKE1@att.net
AL DANQUIST / CPA corrosion Eng (Insp)	CPAI	657-7773 / n1115@conocophillips.com
TIM BIERI / COFFMAN ENGINEERS		276-6664 / bieri@alaska.coffman.com
LYDIA MINER / EPR Section Manager	ADEC	264-7480 / lydia-miner@dec.state.ak.us
SAM SAENGSUDHAM / <del>PTI</del> SECTION MANAGER	ADEC/SPAR	269-5078 / SAM_SAENGSUDHAM@DEC.STATE.AK.US
TED MOORE / EST III	ADEC/SPAR/IPF	267-2567 / TED_MOORE@DEC.STATE.AK.
MARIA CHERRY / Eng & Corr Supv		

NAME/TITLE

COMPANY

PHONE/EMAIL

Gary R Crawford <sup>aka North Slope</sup> TL  
 George Blankenship / BP CPD Ad Mgr  
 John Williams  
 Bill Hutmacher

BP  
 BP  
 BP  
 ADEC

659-5050 <sup>crawfordg@nsl</sup>  
 509-5111 <sup>blankensg@bp</sup>  
 859-5000 / <sup>williamsj@nsl</sup>  
 269-3054 /  
 bill-hutmacher@dec.sta  
 ak.u

BP

28 April 2003



**BP and State of Alaska Charter Agreement**  
**Corrosion Monitoring Review 2002**  
**Meet and Confer V**

**April 28<sup>th</sup>, 2003**

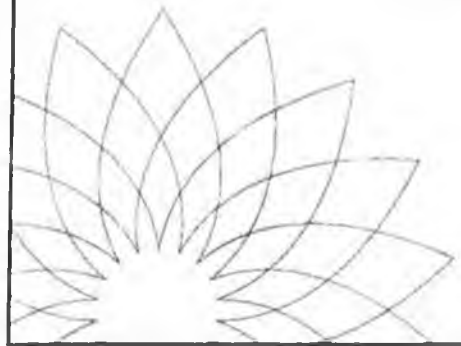

**Outline**

- ▶ **Corrosion Management Program/Objectives**
- ▶ **GPB**
  - » **3 Phase Production**
    - Weight loss coupons
    - ER probe
    - Corrective actions
  - » **Water Injection Systems**
    - Weight loss coupons
    - Corrective actions
  - » **External Corrosion**
    - Inspection
    - Cased Piping Segments
- ▶ **ACT**
  - » **GPB and ACT Comparison**
    - Size and corrosivity
  - » **ACT Highlights**
    - Selected corrosion management examples
- ▶ **Summary**

## Corrosion Management Program



### ▶ Strategic Objectives

- ▶ Minimize HSE Impacts
  - Corrosion loss of containment
- ▶ Fit-for-service Infrastructure
  - Remaining field life
  - With gas sales 50+ years
- ▶ Infrastructure Integrity
  - Satellite fields
  - Use of existing infrastructure
- ▶ Future Major Gas Development
  - Utilize existing facilities
  - Gas sales demands longevity

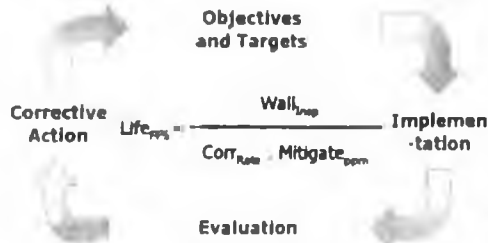

Step  
Plan

**Program Elements**  
**Objective**

Program objective and purpose

**Target**

Performance metric

**Implementation**

Plan to achieve objective

**Evaluation**

Method to evaluate performance

**Corrective Action**

Correct deviation from target

Do

Check

Act

April 2003

BP/ADEC Meet and Confer V

3

## System-by-System Review

bp



### ▶ Elements of Long Term Fitness For Service

- ▶ Corrosion monitoring
- ▶ Inspection
  - Condition
  - Increases
- ▶ Mitigation/corrosion control
- ▶ **Weight Loss Coupons**
  - ▶ Flow Line
  - ▶ Well Line
- ▶ **Inspection Increases**
  - ▶ Correlation between inspection increases and WLC
- ▶ **Equipment Condition**
  - ▶ Increases and condition correlation
- ▶ **Mitigation**
  - ▶ Correlation between corrosion rate and CI concentration

April 2003

BP/ADEC Meet and Confer V

4



### 3 Phase Production

- ▶ **Weight Loss Coupons**
  - ▶▶ Flow lines
  - ▶▶ Well lines
- ▶ **ER Probe Example**
- ▶ **Corrosion Inhibitor Injection**
  - ▶▶ Concentration
  - ▶▶ Water rates
- ▶ **Monitoring Corrective Actions**
  - ▶▶ ER probes and coupons
- ▶ **Inspection**
  - ▶▶ Flow and well line summaries
- ▶ **Inspection Corrective Actions**
- ▶ **3 Phase Inhibition Summary**

April 2003

BP/ADEC Meet and Confer V

5



### 3 Phase – Flow Line Coupons

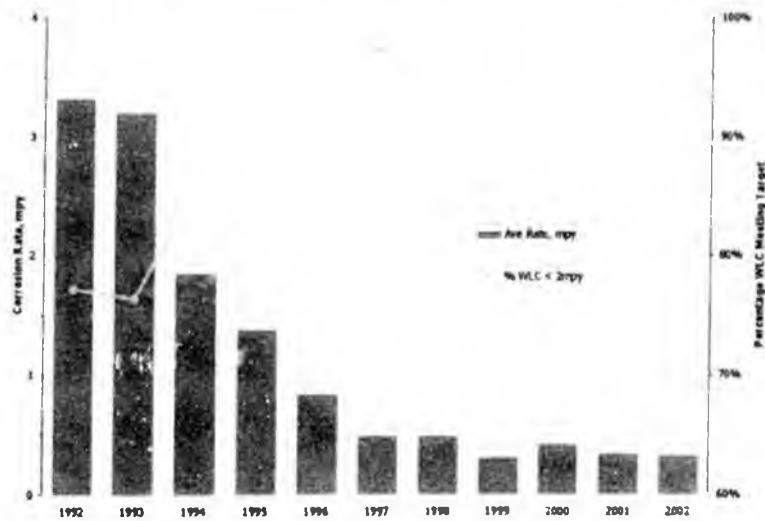

April 2003

BP/ADEC Meet and Confer V

6

### 3 Phase – Well Line Coupons

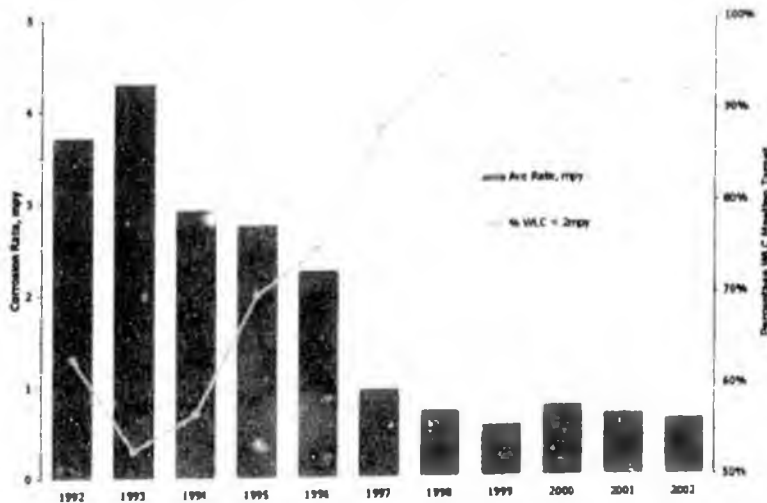

April 2003

BP/ADEC Meet and Confer V

7

*7/3 wells are in continuous well head injection*

### ER Probe Example I

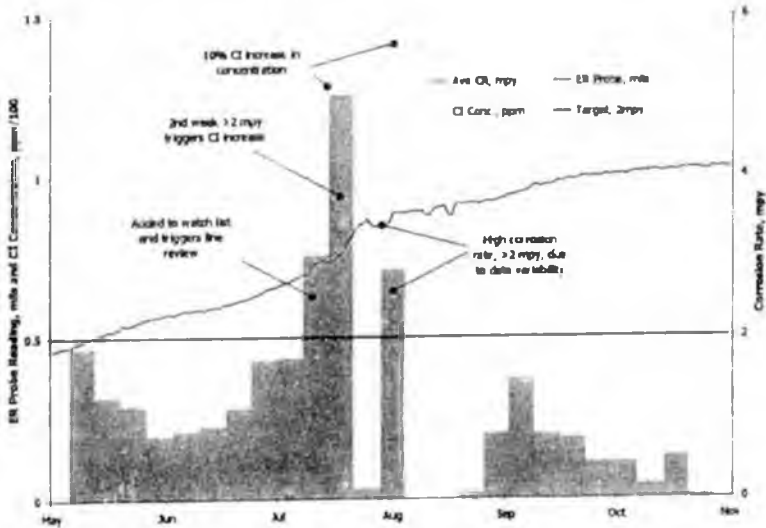

April 2003

BP/ADEC Meet and Confer V

8

## ER Probe Example II

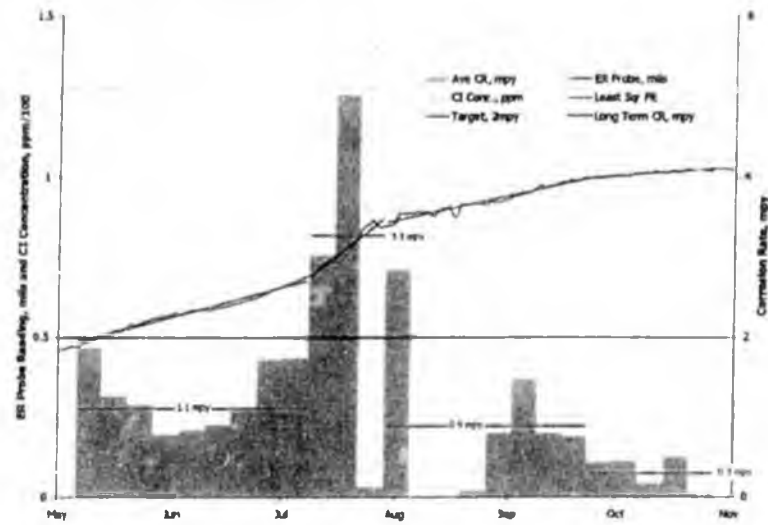

April 2003

BP/ADEC Meet and Confer V

9

## Monitoring Corrective Actions

### ▶ ER Probe Corrective Actions

Equipment ID	Cause	Action
A Pad	Increased Corrosivity	Increased CI by 5%
A Pad	increased Corrosivity	increased CI by 5%
DS04	increased Corrosivity	increased CI by 5%
GRX-E	increased Corrosivity	See Table H 4
A Pad	increased Corrosivity	increased CI by 5%
CL05B	increased Corrosivity	increased from 3 to 4 gpd

### ▶ Coupon Corrective Actions

Equipment ID	Cause	Action
DS14	increased Corrosivity	increased CI by 10%
CL14D	increased Corrosivity	increased CI by 10%
CL05D	increased Corrosivity	increased CI by 20%
F Pad	increased Corrosivity	See Table H 4
Seawater	O <sub>2</sub> Microbiological	Multiple

April 2003

BP/ADEC Meet and Confer V

10

## Inspection Program

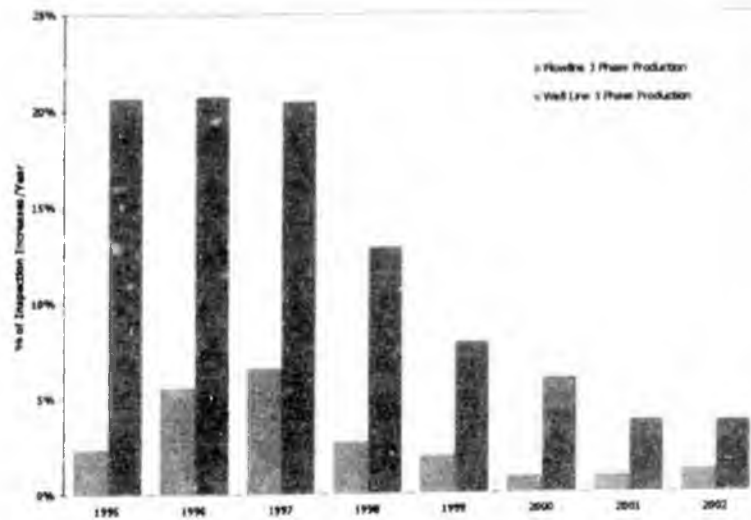

April 2003

BP/ADEC Meet and Confer V

11

## Inspection Corrective Actions



Equipment ID	Cause	Action
D509	Increased Corrosivity	Increased $\square$ by 10%
H Pad	Increased Corrosivity	Increased $\square$ by 10%
F Pad	Increased Corrosivity	Increased $\square$ by 10%
GH-E	Increased Corrosivity	Increased $\square$ by 25%
PW system	Increased Corrosivity	Multiple
SW system	O <sub>2</sub> /Microbiological	Multiple

April 2003

BP/ADEC Meet and Confer V

12

## Corrosion Inhibition Summary I

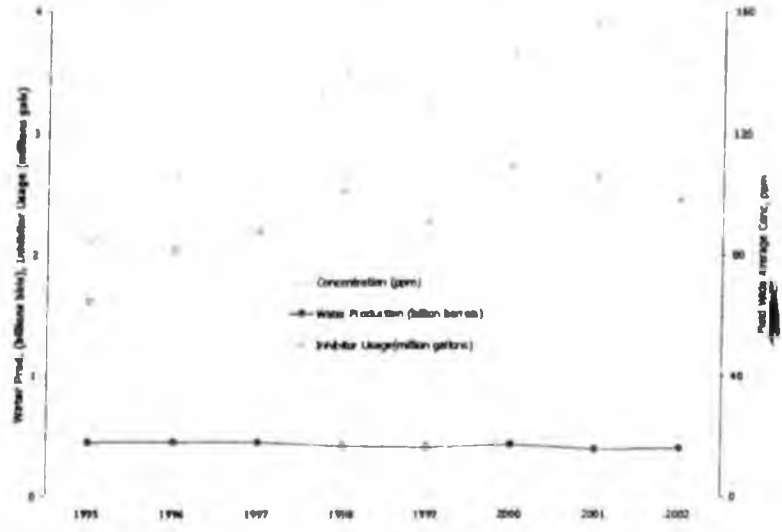

April 2003

BP/ADEC Meet and Confer V

13

## Corrosion Inhibition Summary II



*3 phase Flow Line Coupons*

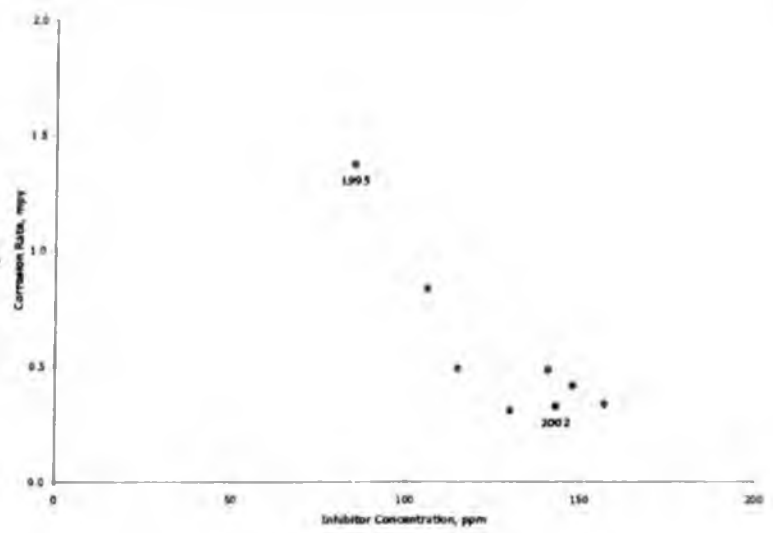

April 2003

BP/ADEC Meet and Confer V

14

## Water Injection Systems



- ▶ **Flow Line Water Injection**
  - ▶ Mixed service
- ▶ **Reporting Format**
  - ▶ Single service
  - ▶ Service plurality
- ▶ **Weight Loss Coupons**
  - ▶ Produced Water system
  - ▶ Seawater system
- ▶ **SW Mitigation**
  - ▶ Oxygen control
  - ▶ Biocide and corrosion rate
- ▶ **Inspection**
  - ▶ Flow and well line

April 2003

BP/ADEC Meet and Confer V

15

*Upstream CI helps*

## Water Injection Flow Line

*dominant*  
*produced water and seawater*

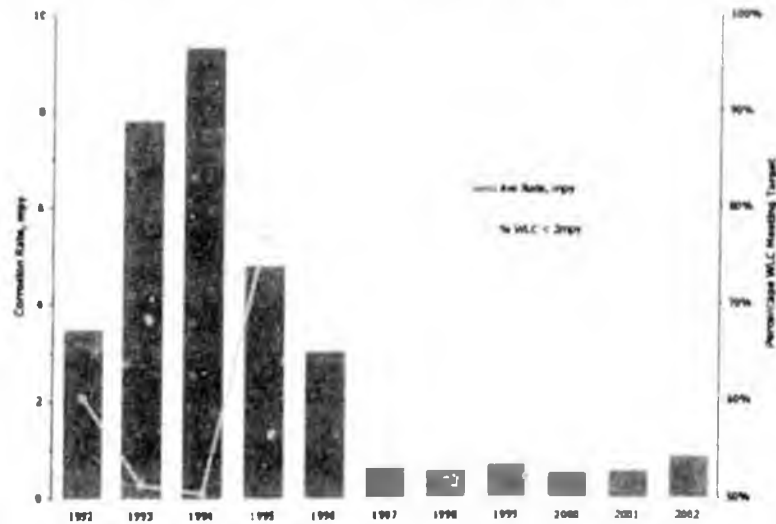

April 2003

BP/ADEC Meet and Confer V

16



## Well Line Reporting Format Change

- ▶ Follow-up to 4Q 2002 Meet and Confer Session
- ▶ Subsequent BP Activities to Address ADEC Concerns
  - ▶ Investment in IT technology
  - ▶ Dynamic link production database with corrosion and inspection database
  - ▶ Positive
    - Can now report detailed service changes
    - Improved data quality and tracking
  - ▶ Negative
    - Change in reported results format
- ▶ Proposed Change to Reporting Format
  - ▶ By Report Date      Mid point of the exposure period  
Date In + (Date Out - Date In)/2
  - ▶ By Service Type      (a) Ave corrosion rate with 100% exposure to service  
                                  (b) Ave corrosion rate with simple service plurality



## PW System - Well Line

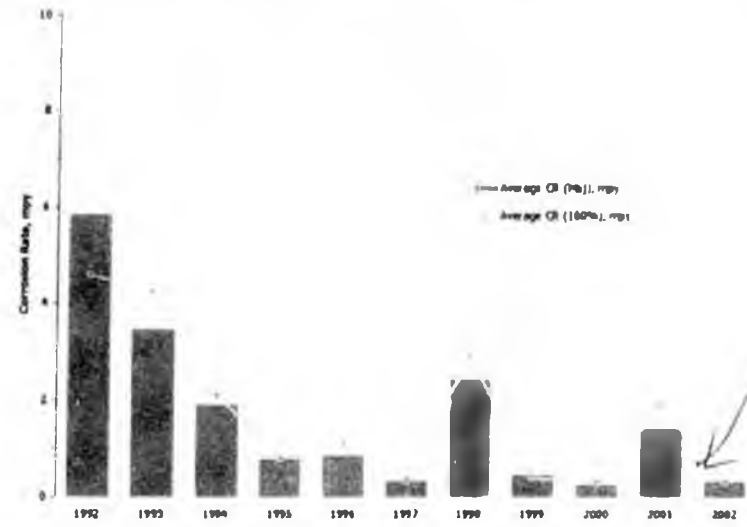

Changed chemical to potentially go to water system.  
Added CI at Island ES3

### SW System – Well Line – Corrosion Rate

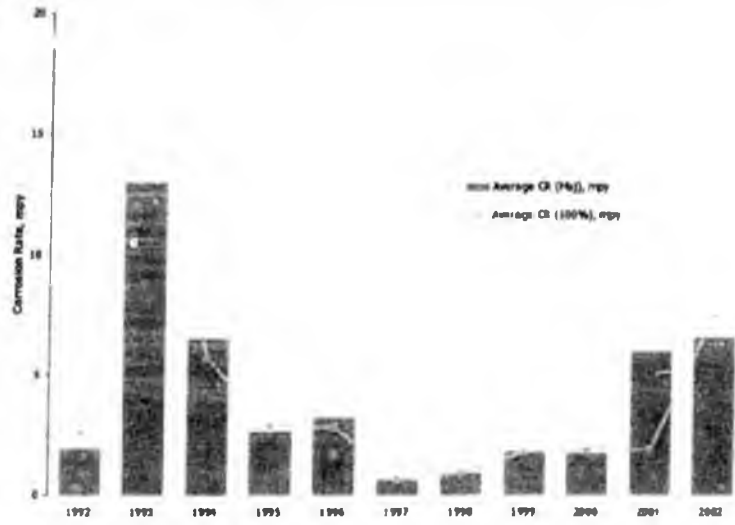

April 2003

BP/ADEC Meet and Confer V

19

*100% SW since is a very small data set (about 5 coupons)*

### SW System – Well Line – Pitting Rate

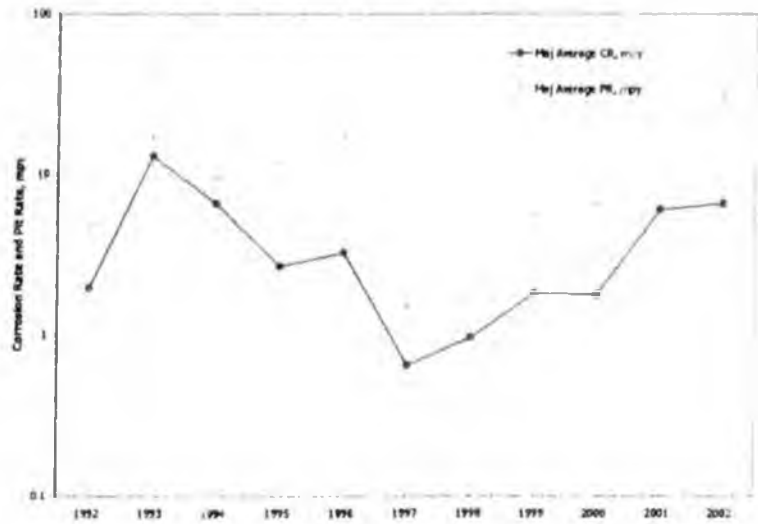

April 2003

BP/ADEC Meet and Confer V

20

## 2002 Oxygen Control

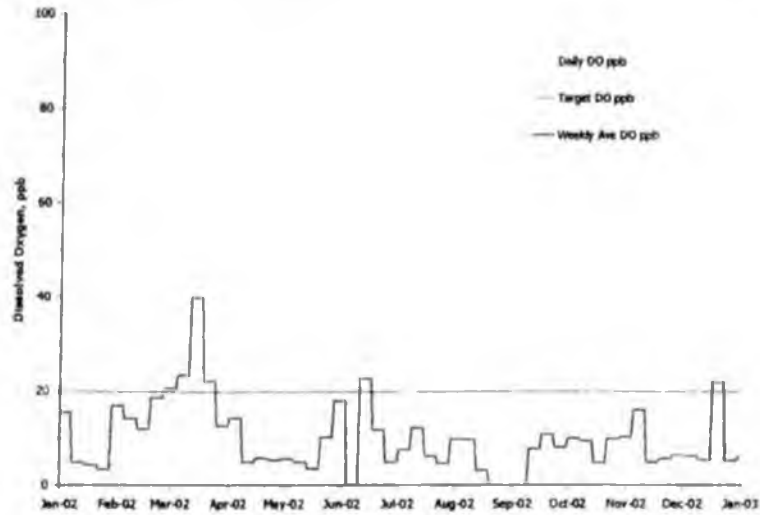

April 2003

BP/ADEC Meet and Confer V

21

## Biocide and Corrosion Rate

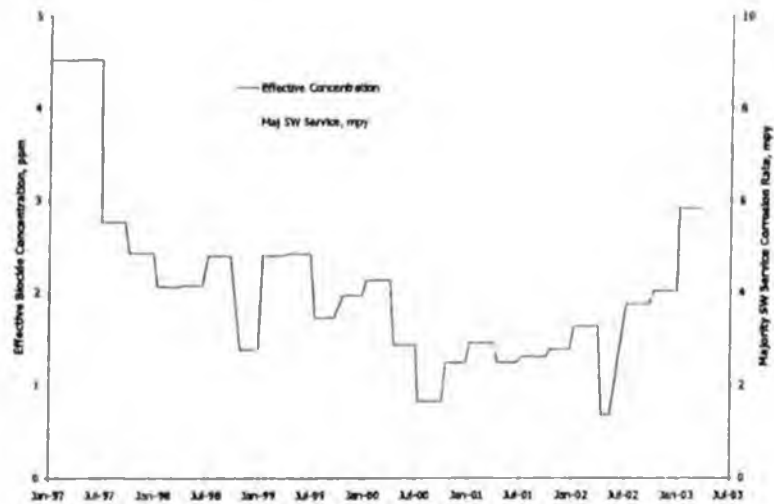

April 2003

BP/ADEC Meet and Confer V

22

## Flow and Well Line Inspection

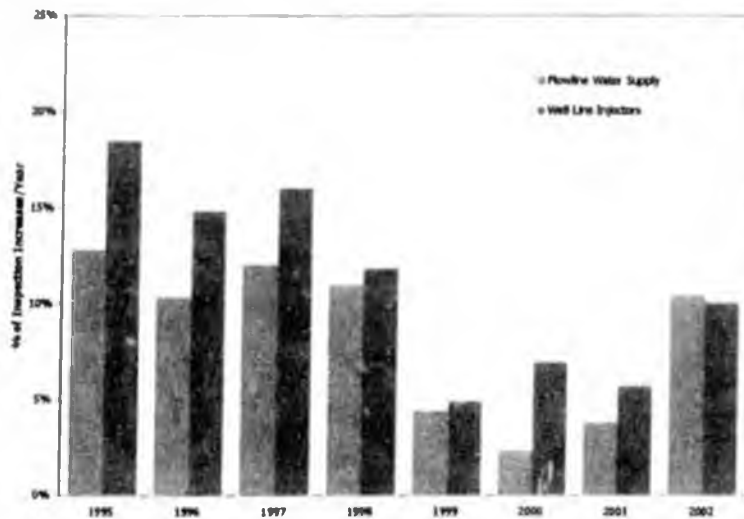

April 2003

BP/ADEC Meet and Confer V

23

## External Corrosion Inspection

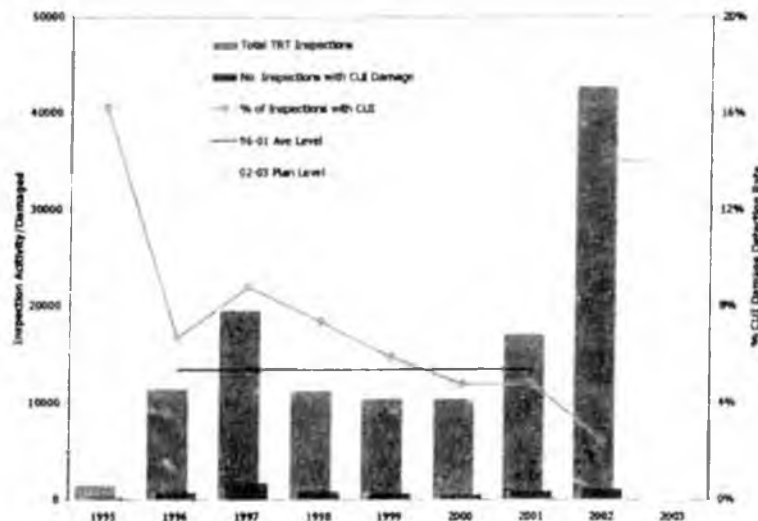

April 2003

BP/ADEC Meet and Confer V

24

## Cased Piping Inspection I

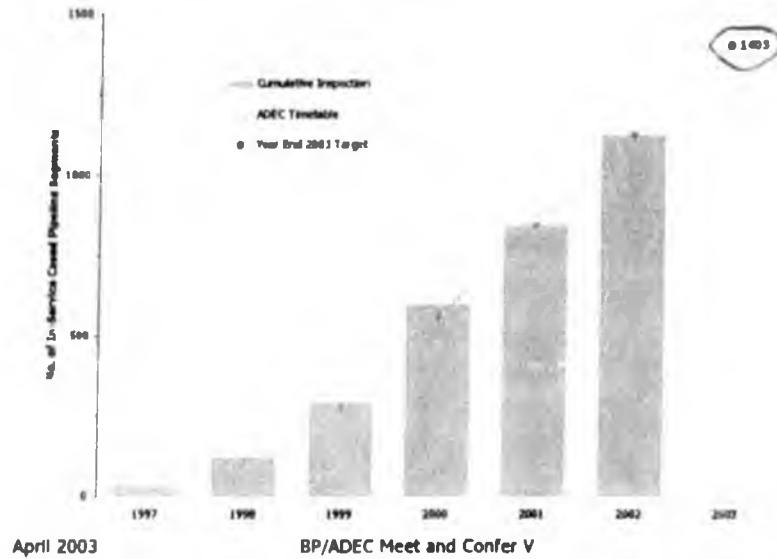

## Cased Piping Inspection II

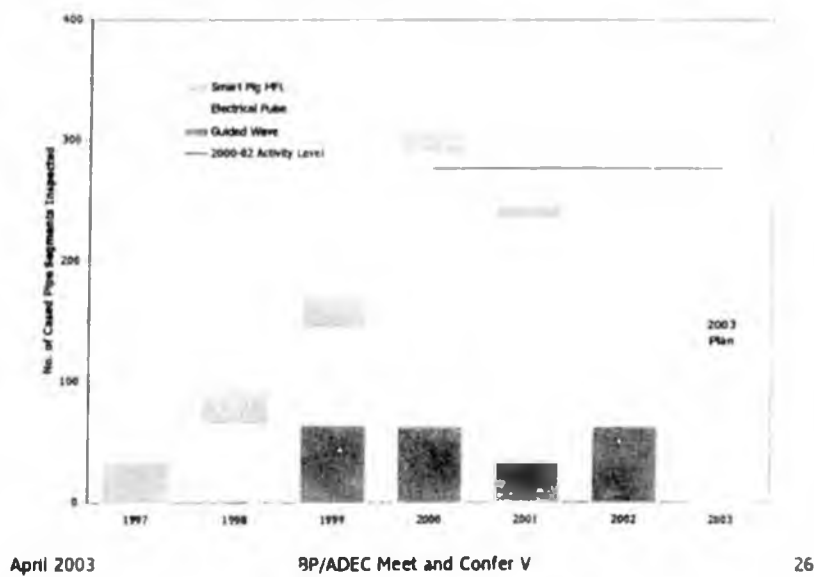



## 2002 Program Performance I

### ▶ 4 Corrosion Related Leaks in 2002

Service	Location	Type	Date	Mechanism	Volume
3 phase production	F-48	S-riser	14-Jan-02	Erosion	115 gal
	H-21	S-riser	18-Apr-02	Int	84 gal
	13-12	WL	14-Jun-02	Ext	1 qt
	Z-LDF	FL	4-Oct-02	Ext	4 gal

	Surface		Service		Mechanism		
	Int	Ext	OIL	SW/PW	CO <sub>2</sub>	Erosion	CUI
WL	2	1	3		1	1	1
FL		1	1				1

### ▶ Repairs

- ▶▶ 78 repairs
  - 57 - external corrosion
  - 20 - internal/erosion
  - 1 - mechanical damage

April 2003

BP/ADEC Meet and Confer V

27



## 2002 Overview

### ▶ Maintained Three-Phase System

- ▶▶ No impact as a result of chemical change

### ▶ SW/PW Program Improvement

- ▶▶ Seawater
  - Performance improvement from implemented corrective actions
  - Additional actions as required in 2003
- ▶▶ Produced water
  - Supplemental corrosion inhibitor
  - Improved compatibility of upstream inhibition

### ▶ Inspection Program

- ▶▶ Implementation of expanded External Corrosion Program
  - ~43,000 items versus historical ~13,000
- ▶▶ Baseline Inspection of cased piping segments
  - ~269 segments to be inspected in 2002
  - On target to complete baseline in 2003

April 2003

BP/ADEC Meet and Confer V

28



## 2002 Corrosion Rate Status Against History

\* Difference Between CR 2002 and Best in Last 10 Years / Difference Between CR 2002 and Worst in the Last 10 Years

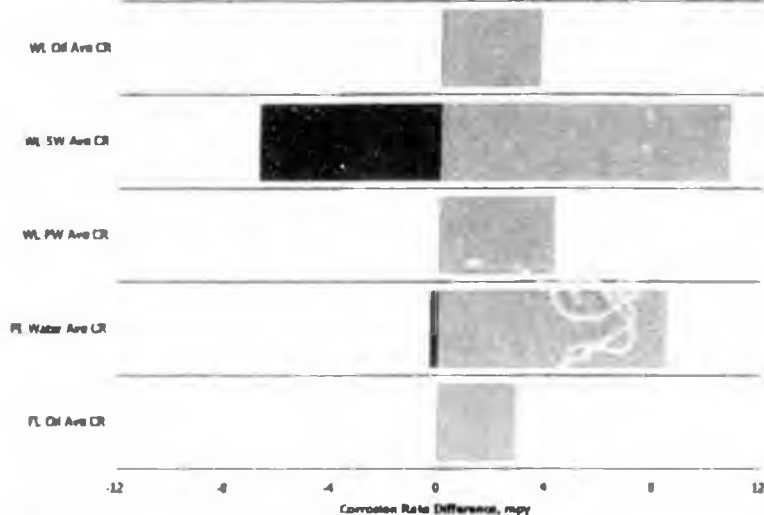

April 2003

BP/ADEC Meet and Confer V

29



## GPB 2003 Goals and Objectives

- ▶ **Corrosion Monitoring**
  - ▶▶ Coupon – no significant changes
  - ▶▶ ER probes – no significant changes
- ▶ **Inspection Program**
  - ▶▶ No significant changes planned for 2003
- ▶ **External Corrosion Inspection**
  - ▶▶ Weld pack inspections ~35,000
- ▶ **Cased Piping Inspection**
  - ▶▶ Complete baseline assessments
- ▶ **Chemical Mitigation**
  - ▶▶ Large scale changes – none planned
  - ▶▶ Testing/field trials – significant activity planned
- ▶ **Technology**
  - ▶▶ High speed/sensitivity ER probes
  - ▶▶ Remote tank strap reading – CI trucks

April 2003

BP/ADEC Meet and Confer V

30

*to monitor injection rate*



## Alaska Consolidated Team (ACT)

### ▶ Producing Fields

- ▶▶ Endicott
- ▶▶ Milne Point
- ▶▶ Badami
- ▶▶ Northstar

### ▶ Relative Comparison

- ▶▶ ACT smaller than GPB
- ▶▶ Differences in age
- ▶▶ Non-common carrier FL
  - None at Northstar
  - None at Badami
- ▶▶ Materials of construction

Metric	ACT	GPB	ACT (ACT / GPB)
Production Trains	4	21	16%
Prod and Inj Wells	230	1475	13%
Non-common carrier FL	105	1350	7%
Acreage	75000	203000	27%

April 2003

BP/ADEC Meet and Confer V

31

bp



## Relative Corrosivity of BP North Slope Fields

Field	Prod Fluid Characteristics				Material of Construction <sup>(a)</sup>			
	H <sub>2</sub> O, %	T °F	P <sub>CO2</sub> %	CR <sup>(b)</sup>	Production		Injection	
					WL	PL	WL	PL
GPB	70	150	12	H	CS+CI	CS+CI <sup>(c)</sup>	CS+CI	CS+CI
END	90	150	18	H	DSS	D+SS	CS+CI	CS+CI
MPU	47	125	1.5	L/M	CS	CS <sup>(d)</sup>	CS+CI	CS+CI
Northstar	0.8	160	5	M	CS+CI	N/A	N/A	N/A
Badami	0.3	65	0	L	CS	N/A	N/A	N/A

Notes

(a) CS is carbon steel, CI is corrosion inhibitor, DSS is duplex stainless steel

(b) Unmitigated relative corrosion rate, H - high, M - medium, and L - low

(c) There are a limited number of Duplex Stainless Steel flow lines in GPB

(d) Two production flow lines are inhibited at MPU

April 2003

BP/ADEC Meet and Confer V

32



## Endicott Overview

### ► Production System

- Primarily Duplex Stainless Steel
- Exception are the carbon steel C-spools
  - Velocity monitoring
  - Inspection program
  - Manage to repair/replace

### ► PWSW Injection System

- Inter-Island Water Line (IIWL) main concern
  - Control by:
    - Maintenance pigging
    - Biocide
    - Inhibition (Increased in 2003)

### ► External Corrosion

- Primary 2002 focus on common-carrier oil sales line

April 2003

BP/ADEC Meet and Confer V

33



## Endicott IIWL Quarterly UT Inspections

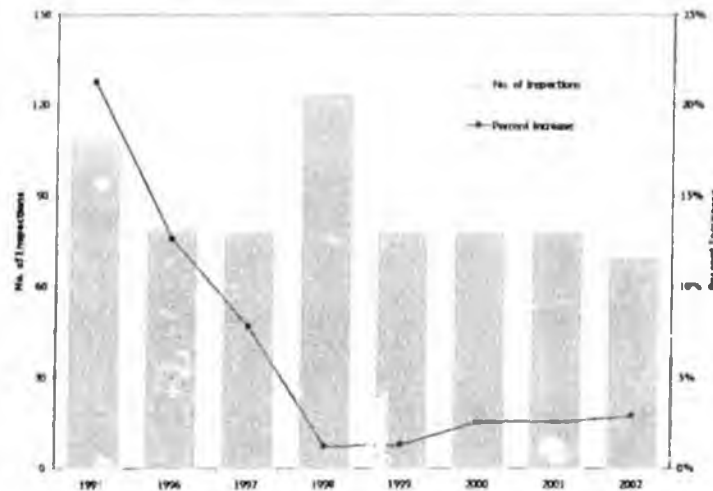

April 2003

BP/ADEC Meet ar. 1 Confer V

34

## Milne Point Unit Overview



### ▶ Production System

- ▶ Initiating inhibition program
  - K-Pad flow line initiated in 2001
  - New S-Pad designed for inhibition
  - Remaining facilities under review for inhibition
    - Flow characteristics
    - Inspection and corrosion monitoring data

*Continuous treatment*

### ▶ Water Injection system

- ▶ Inhibition initiated in 2000
- ▶ Along with more aggressive maintenance rigging program
- ▶ Significant decrease in corrosion activity

### ▶ External Corrosion

- ▶ Primary 2002 focus on common-carrier oil sales line
- ▶ Five excavations on I-Pad
  - 70 inspection items - 8 with corrosion with < 20% wall loss

April 2003

BP/ADEC Meet and Confer V

35

## MPU Produced Water Corrosion Rate Trend

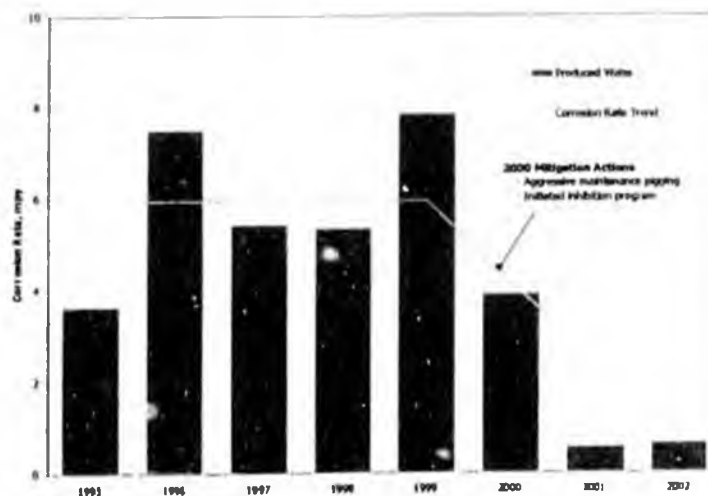

April 2003

BP/ADEC Meet and Confer V

36



## Badami and Northstar

### ▶ Badami

- ▶ On production since 1998
- ▶ Production well below expectations
- ▶ No water injection system
  - Water cut <1%
- ▶ No significant corrosion experienced

### ▶ Northstar

- ▶ On stream in late 2001
- ▶ Continuous inhibition into well production lines
- ▶ No water injection system
  - Water cut <1%
- ▶ Corrosion monitoring program developing
- ▶ Inspection baseline and historical record being established

April 2003

BP/ADEC Meet and Confer V

37



## ACT – Corrosion/Structural Related Spills

Service	Leaks	Saves	Sleeves	Comments
Oil Flow lines	0	0	0	
Oil Well Lines	0	6	0	Well 2-30 erosion
Water Flow lines	0	1	0	
Water Well Lines	1	0	0	Well 1-31 pin hole
GLT/MI Flow lines	0	0	0	
GLT/MI Well lines	0	0	0	

April 2003

BP/ADEC Meet and Confer V

38



## ACT 2003 Goals and Objectives

- ▶ **Endicott**
  - ▶ Inter-Island Water Line (IIWL) and PW/SW well lines
    - Slight increase based on inspection data - Inhibitor Increase Apr-03
- ▶ **Northstar**
  - ▶ Continue to establish corrosion monitoring and inspection history
  - ▶ Inspection and mitigation programs responding as appropriate
- ▶ **Badami**
  - ▶ Relatively low corrosivity
  - ▶ No major changes are anticipated
- ▶ **Milne Point Unit**
  - ▶ Continuing to build a more comprehensive baseline inspection
  - ▶ Inspection and mitigation programs responding as appropriate
  - ▶ Developing 3 Phase System Program
    - Continued analysis of production flow lines
    - Initiate corrosion inhibition as applicable
  - ▶ Buried flow lines
    - Trial GUT technology that uses fixed monitoring locations

April 2003

BP/ADEC Meet and Confer V

39



## Summary

- ▶ **Delivery of Objectives**
  - ▶ Long term Fitness For Service
- ▶ **Corrosion Management System**
  - ▶ Integration of key elements
    - Thickness - Inspection program
    - Rate - Corrosion monitoring
    - Mitigation - Corrosion inhibition
- ▶ **GP Focus for 2003**
  - ▶ 3-Phase - Maintain performance
  - ▶ SW - DO and MIC control
  - ▶ PW - Monitor effects of chemical change
- ▶ **ACT Focus for 2003**
  - ▶ Badami - monitor fit status
  - ▶ Northstar - respond to baseline data
  - ▶ Endicott - PW/SW injection system
  - ▶ Milne Point - 3 phase production system

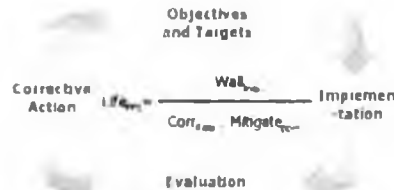

April 2003

BP/ADEC Meet and Confer V

40

# Commitment to Corrosion Monitoring

30 October 2003  
10:00 am to 3:00 pm

ConocoPhillips Building 700 "G" Street  
Conference Room ATO-1167

2<sup>nd</sup>-Half 2003 Meet and Confer  
(Meeting # 6)

## Agenda

Introductions/Opening Remarks – (10:00 to 10:30 am)

- ConocoPhillips new staffing
- ADEC update on new staffing for Charter *(Horne, - Mike. Watts)*
- BP new staffing

BP Review (10:30 to 11:45 am)

Lunch in ATO-1167 (11:45 am to 12:45 pm)

ConocoPhillips Review (12:45 to 2:00 pm)

ADEC (2:00 to 2:30pm)

Open discussion, questions, and feedback (2:30 to 3:00 pm)

*Mike. Watts - gave notice mid-October - maybe using Oliver  
from CC Technologies now*

*→ Line marking minimum should be contact identified*

*→ 4-36 Flow line spill - final report*



**BP and State of Alaska Charter Agreement**  
**Corrosion Monitoring Review 2003**  
**Meet and Confer VI**

October 30<sup>th</sup>, 2003

*Focus on Gr Prudhoe Bay*



**Outline**

- ▶ **Corrosion Monitoring**
  - ▶ 3 Phase Production
    - Flow line and well line coupons
  - ▶ Water Injection System
    - Flow line and well line
- ▶ **Internal Inspection**
  - ▶ 3 Phase
  - ▶ Water injection
- ▶ **External Corrosion**
- ▶ **Cased Piping Inspection**
- ▶ **Smart Pigging Activity**
- ▶ **2003 Corrosion Related Spills**
  - ▶ Y-36 incident and follow-up
- ▶ **Summary**

## Corrosion Monitoring 3 Phase Production



- ▶ **Weight Loss Coupons**
  - ▶ Well lines
  - ▶ Flow lines
- ▶ **Monitoring Corrective Actions**
  - ▶ ER probes and coupons
- ▶ **ER Probe Example**
- ▶ **Corrosion Inhibitor Injection**
  - ▶ Concentration
  - ▶ Water rates
- ▶ **Inspection**
  - ▶ Flow and well line summaries
- ▶ **Inspection Corrective Actions**
- ▶ **3 Phase Inhibition Summary**

Oct 2003

BP/ADEC Meet and Confer VI

3

## 3 Phase – Well Line Coupons

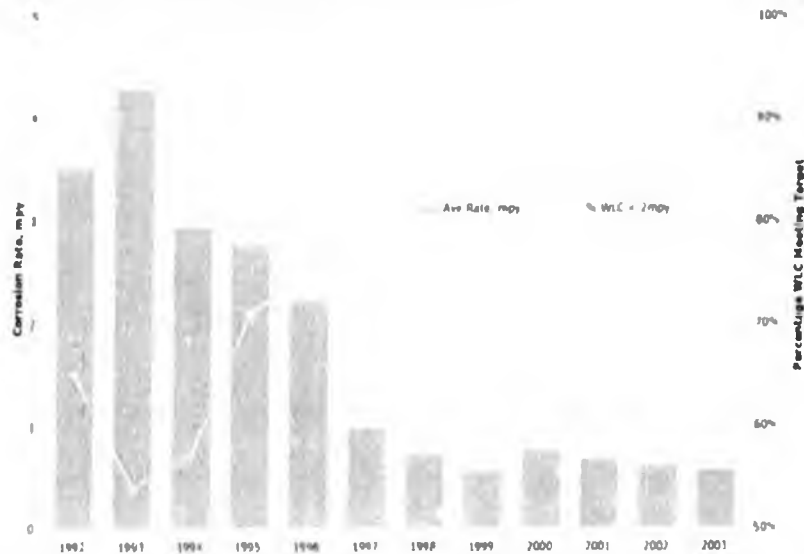

Oct 2003

BP/ADEC Meet and Confer VI

4

### 3 Phase- Flow Line Coupons

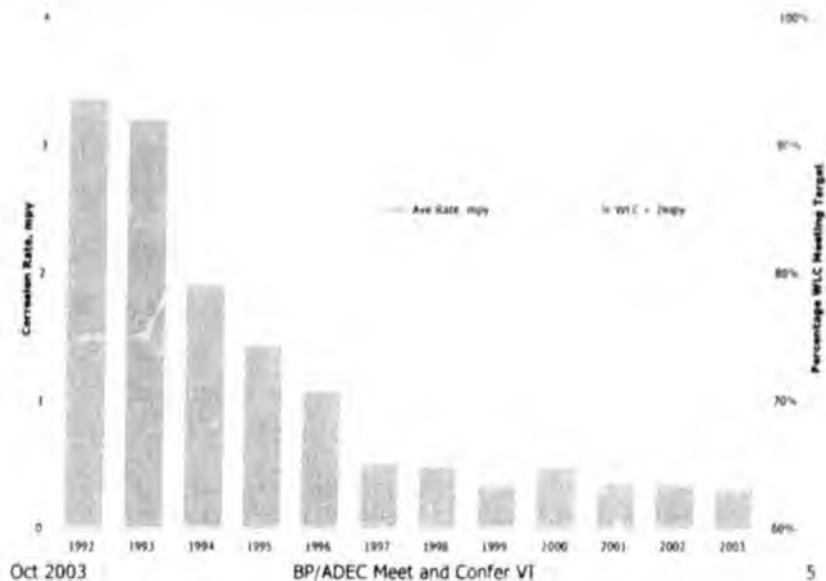

### 1997 Onward- Corrosion Rate Focus

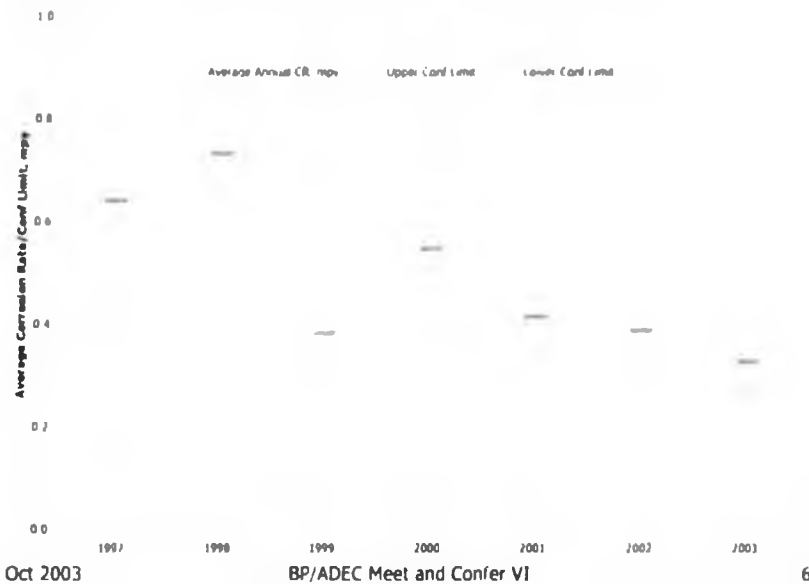

*Review on a weekly basis and response*

## Flow Line Monitoring Corrective Actions



### ER Probes

	No.	Equip ID
⇨ Action	6	01D
⇨ Action	3	03D Y-36
⇨ Action	1	01C 05D 17D F-49 16D

Equip ID	Cause	Action
03D	Increased Corrosivity	Increased CI by 6 gpd
05D	Increased Corrosivity	Increased CI by 25 gpd
17D	Increased Corrosivity	Increased CI by 5%
01D	Increased Corrosivity	Increased CI by 5%
03D	Increased Corrosivity	Increased CI by 10%
01D	Increased Corrosivity	Increased CI by 5%
01D	Increased Corrosivity	Increased CI by 5%
01D	Increased Corrosivity	Increased CI 18 gpd
01D & 01C	Increased Corrosivity	Increased CI by 5%
01D	Increased Corrosivity	Increased CI by 10%
03D	Increased Corrosivity	Increased CI by 5%
F-49	Increased Corrosivity	Increased CI by 5%
16D	Increased Corrosivity	Increased CI by 5%
Y-36	Increased Corrosivity	Increased CI by 10%
Y-36	Increased Corrosivity	Increased CI by 10%
Y-36	Increased Corrosivity	Production routing change

### Weight Loss Coupons

Equip ID	Cause	Action
14D	Increased Corrosivity	Increased CI by 10%
Q-01	Increased Corrosivity	Increased CI by -100%

Oct 2003

BP/ADEC Meet and Confer VI

7

## ER Probe Corrective Action Example

(10)

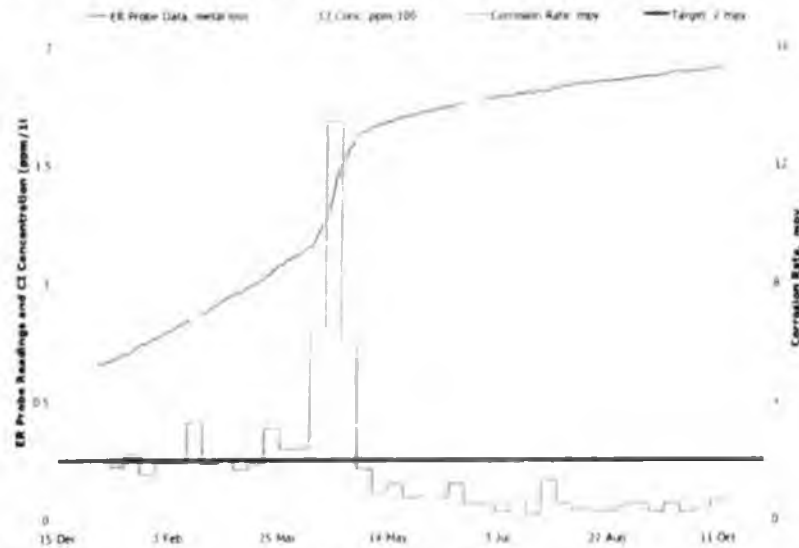

Oct 2003

BP/ADEC Meet and Confer VI

8

## GPB Wide Corrosion Inhibitor Concentrations

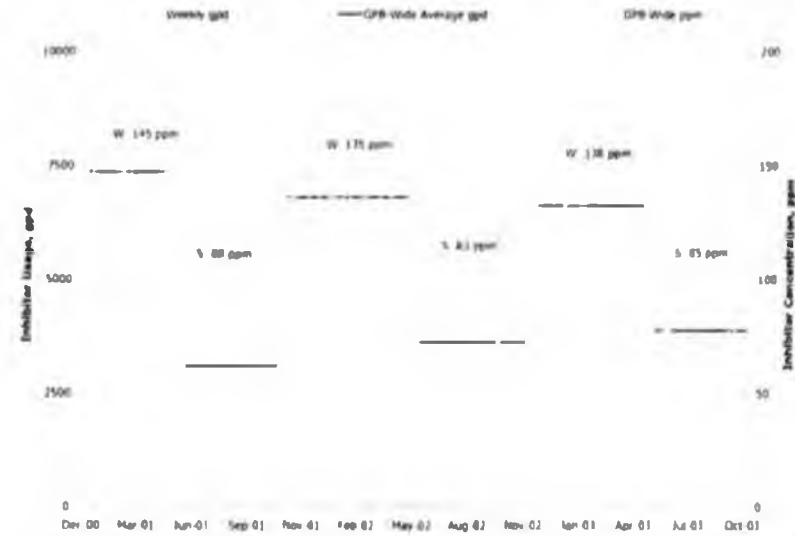

Oct 2003

BP/ADEC Meet and Confer VI

9

*Winter  
Summer  
use different blends  
of corrosion inhibitors  
seasonally*

## Water Injection Systems

- ▶ **Flow Line Water Injection**
  - ▶ Mixed service
- ▶ **Well Line Reporting Format**
  - ▶ Single service
  - ▶ Service plurality
- ▶ **Weight Loss Coupons**
  - ▶ Produced Water system
  - ▶ Seawater system
- ▶ **SW Mitigation Update**
  - ▶ Oxygen control
  - ▶ Biocide and corrosion rate
- ▶ **Inspection**
  - ▶ Flow and well line

Oct 2003

BP/ADEC Meet and Confer VI

10

### Aggregate Water Injection Flow Line Coupons

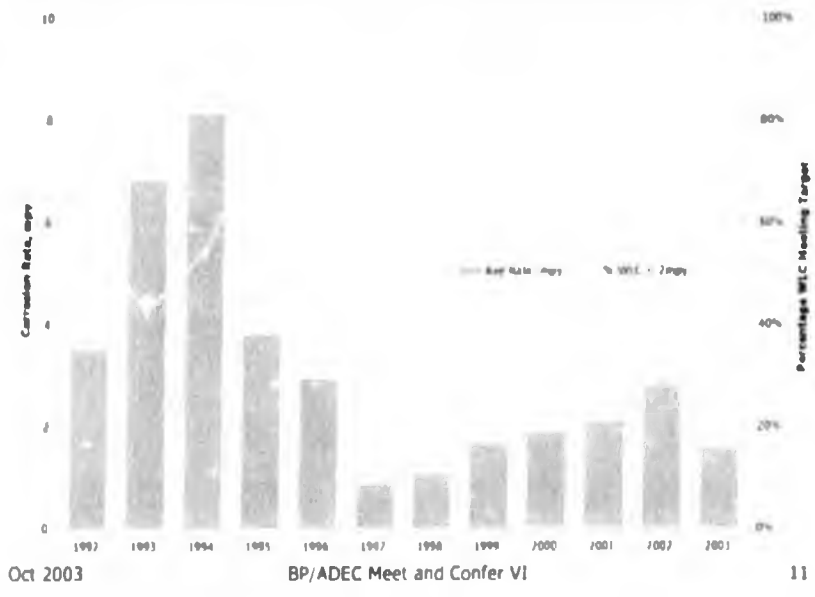

### PW System— Well Line Coupons

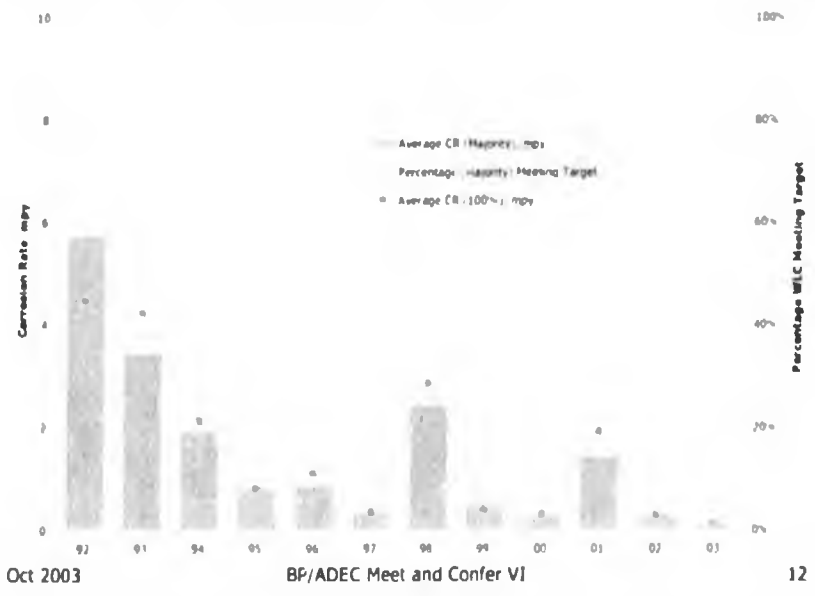

## SW System- 2002/2003 Corrective Actions



- ▶ **Upstream Corrosion Control**
  - ▶ Improved dissolved oxygen control
- ▶ **Downstream Corrosion Control**
  - ▶ Improved microbiological/biocide efficacy
- ▶ **Oxygen Control- Corrective Actions**
  - ▶ Set O<sub>2</sub> control < 20 ppb
    - Mechanical fixes to tower
    - Continuous O<sub>2</sub> scavenger
- ▶ **Microbiological- Corrective Action**
  - ▶ Increased biocide frequency
    - 2002 from once every two weeks to once a week
  - ▶ Increased effective biocide concentration
    - 2003 from 500 ppm to 750 ppm
    - Increases downstream biocide residual levels

Oct 2003

BP/ADEC Meet and Confer VI

13

## SW System- Well Line Coupons

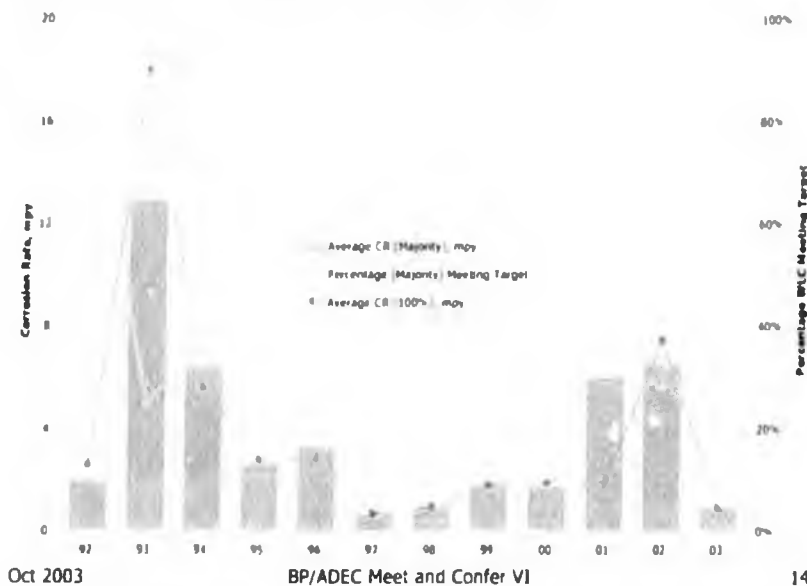

Oct 2003

BP/ADEC Meet and Confer VI

14

*1993 - most time in service since*

*100% - old time in service since*

*Limited data set*

*Extended shutdown period not considered*

## Inspection Program

- ▶ **Inspection Activity**
  - ▶ Internal
  - ▶ External
- ▶ **Internal Inspection**
  - ▶ 3 phase - flow and well line
    - Flow line corrective action
  - ▶ Water Injection - flow and well line
- ▶ **External Inspection**
  - ▶ Activity level
- ▶ **Cased Piping Inspection**
  - ▶ Activity level
  - ▶ Type and method
- ▶ **Smart Pigging Activity**
- ▶ **Spill Summary**
  - ▶ Y-36 Incident

*Changed internal inspection contractor*

Oct 2003

BP/ADEC Meet and Confer VI

15

## Flow/Well Line Inspection Activity

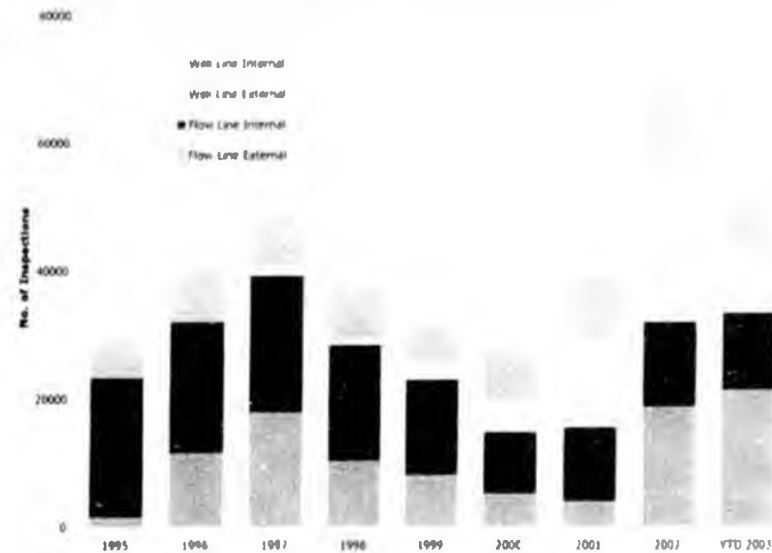

Oct 2003

BP/ADEC Meet and Confer VI

16

*External 30,000 from year should be met  
No change in inspection activity (internal)*

### 3 Phase Inspection Program

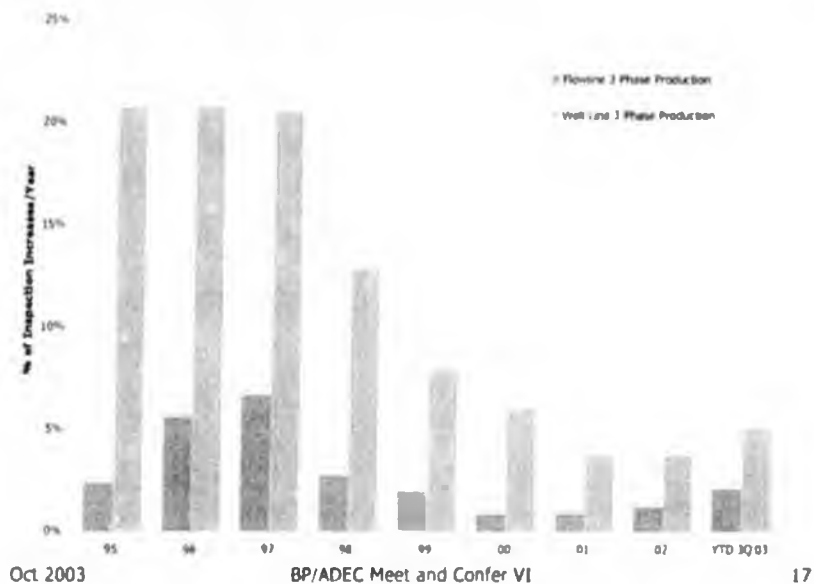

Oct 2003

BP/ADEC Meet and Confer VI

17

### Flow Line Inspection- Corrective Actions



#### ► Inspection

Equipment ID	Cause	Action
Y36	Increased Corrosivity	See ER Probe Action Log
16C/17C	Increased Corrosivity	Increased CI by 5%
W-74	Increased Corrosivity	Increased CI by 10%

Oct 2003

BP/ADEC Meet and Confer VI

18

## Water Injection Inspection Program

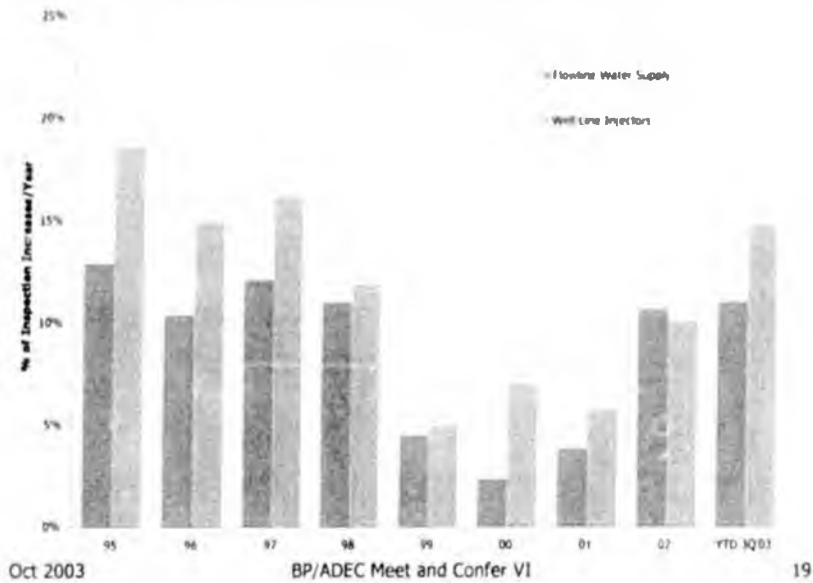

## External Corrosion Inspection

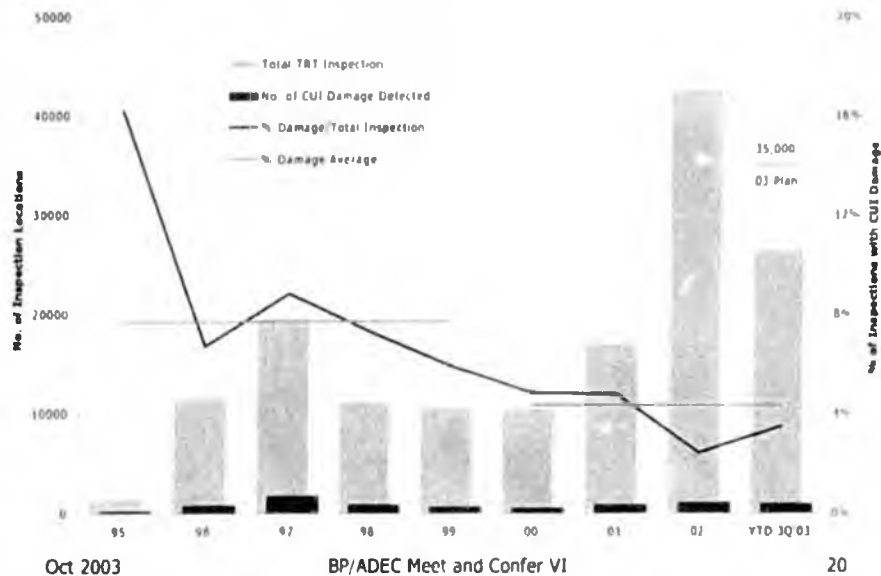

## Cased Pipe Inspection I



### ► Completed Initial Baseline Inspection

► Awaiting 2003 NDE provider(s) report

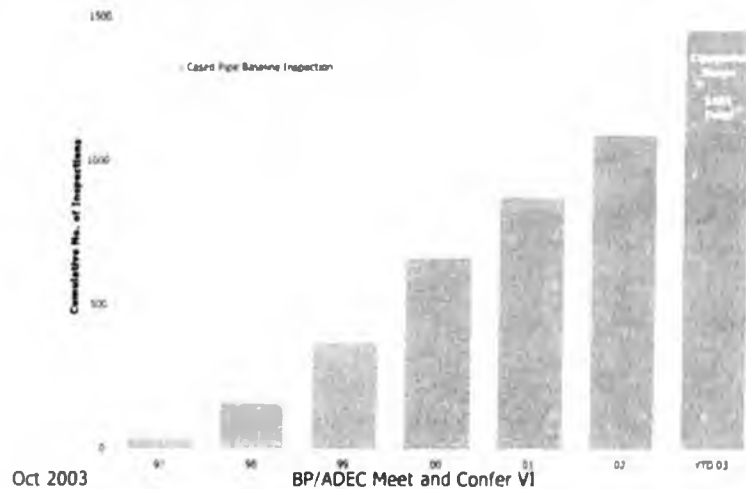

Oct 2003

BP/ADEC Meet and Confer VI

21

## Cased Piping Inspection II



### ► Inspection Activity

► Baseline plus repeat inspection

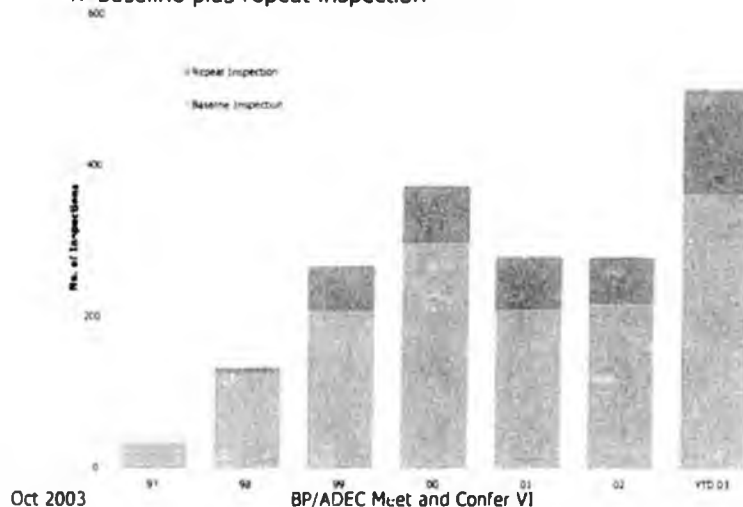

Oct 2003

BP/ADEC Meet and Confer VI

22

## Cased Piping Inspection III

### ▶ Inspection Activity

#### ▶ NDE Method

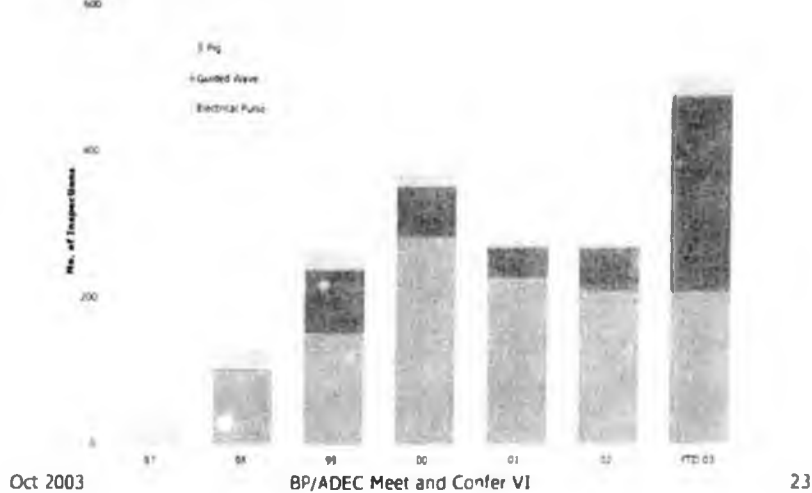

*Not many lines  
can be smart  
pigged.*

## Smart Pig Inspection

### ▶ Completed 3Q'03

Equipment ID	Diameter	Material Thickness	From	To	Service	Length (miles)
PTMCLS01/02	24"	0.375"	Drill Site L1	LPC	3 Phase Production	5
S-36	24"	0.375"	S Pad	GC2	3 Phase Production	6
Y-36	24"	0.375"	Y Pad	GC1	3 Phase Production	6

### ▶ Tentative 4Q'03

Equipment ID	Diameter	Material Thickness	From	To	Service	Length (miles)
STP-36	36"	0.375"	PM2	GC1	3 Phase Production	~11

Oct 2003

BP/ADEC Meet and Confer VI

24

## Smart Pig Inspection II

*Fit for Service*



### ► Interim Report

- 2 locations on PTMCLS01/02 *Flagged as potential problems*
- Field verification of interim report damage assessment
  - FFS assessed by PR-3-805 Modified Criterion as cited in CFR 195
  - 1<sup>st</sup> location
    - CUI damage - failed B31.4 80% criteria
    - Line immediately shut-in and sectional repair completed
  - 2<sup>nd</sup> location
    - Coincident internal and external damage
    - Fit-for-service with MOP greater than design

### ► Final reports

- Not yet received

### ► Smart Pig FollowUp

- Validation and verification with NDE
- Results reported under routine NDE

Oct 2003

BP/ADEC Meet and Confer VI

25

## YTD 2003 Spill Summary



### ► Spill Location Summary

	Affected Surface	
	Internal	External
Well Line	-	-
Flow Line	-	1

### ► Spill Mechanism Summary

	Mechanism		
	CO <sub>2</sub>	Erosion	CUI
Well Line	-	-	-
Flow Line	-	-	1

### ► Spill Fluid Summary

	Service		
	Prod	SW	PW
Well Line	-	-	-
Flow Line	1	-	-

Oct 2003

BP/ADEC Meet and Confer VI

26

*Remove insulation  
back 5 feet*

## Y-36 Large Diameter Flowline

### ▶ Incident Summary

- ▶ May 27<sup>th</sup> 2003 leak detected
- ▶ Line shut-in and insulation removed
- ▶ Leak occurred at caribou crossing

### ▶ Inspection

- ▶ Gravel and casing cut back approx. 8'
- ▶ Corrosion network present 360°
  - Leak at 06:00 o'clock position
  - Network stopped 12" inside of insulation

### ▶ Cause

- ▶ Failure caused by external corrosion
  - Water ingress via UT insulation 'window'

### ▶ Corrective Action Plan

- ▶ Sleeve installed at location
- ▶ Additional visual/NDE inspection
  - Similar configurations across GPB



Line leak and sleeve installation



Oct 2003

BP/ADEC Meet and Confer VI

27

## Y-36 Corrective Action Plan Scope

### ▶ Visual Inspection of All Below Grade Piping *2/14/05*

- ▶ Observations recorded at each crossing
  - Insulation missing/damaged
    - Evidence of corrosion/visible by-product
  - Tide/water marks
  - Casing blockage/debris
  - Casing overburden
  - Non-bearing/unsupported pipe

- ▶ Review inspection history
- ▶ Audit cased pipe inventory records

### ▶ Additional 2003 Cased Pipe Inspection Over Plan

- ▶ All segments with missing insulation at or near crossing
- ▶ All segments with water/tide marks not examined in prior 3 years
- ▶ Any segments resulting from audit not inspected

*1701 includes copied*

*above original plan*

Oct 2003

BP/ADEC Meet and Confer VI

28

## Y-36 Corrective Action Plan- YTD Progress I



- ▶ **Visual Survey and Audit Completed**
  - ▶▶ Observed 31 segments with external corrosion at missing insulation
  - ▶▶ All locations with missing insulation identified
- ▶ **NDE Follow-up**
  - ▶▶ 31 locations examined and prioritized by TRT
    - 3 locations for immediate excavation/mitigation
    - 28 locations added to expanded 2003 NDE program
  - ▶▶ 3 Segments - Excavation/Mitigation
    - Sleeve repair upstream/downstream - 1 crossing (24" X-74)
    - Replaced complete pipe segment - 1 crossing (14" NGI/CCP)
    - Location fit-for-service - 1 crossing (24" F-74)
- ▶ **Additional 2003 Inspection Program**
  - ▶▶ Increased cased pipe NDE scope by ~200 segments
  - ▶▶ Total 2003 program scope ~500 locations

Oct 2003

BP/ADEC Meet and Confer VI

29

## Y-36 Corrective Action Plan- YTD Progress II



- ▶ **2003 Cased Pipe Scope Breakdown**

	No.	%	Notes
▶▶ Electrical Pulse	207	41%	
▶▶ Guided Wave	268	54%	28 with corrosion All with missing insulation Electrical pulse validation
▶▶ Smart Pigging	25	5%	Includes Y-36 post spill
- ▶ **Thermal Insulation**
  - ▶▶ Replacement of missing insulation at cased crossing
    - On-going ~75% complete *by end of year*
- ▶ **Outstanding Actions**
  - ▶▶ Awaiting final analysis of cased pipe inspection results
  - ▶▶ Develop recommendation/prioritization of reported damage
  - ▶▶ Develop long term cased pipe program
    - On-going activity versus baseline
    - Monitoring versus discovery

Oct 2003

BP/ADEC Meet and Confer VI

30



## Summary

### ▶ Internal Corrosion

- ▶ 3 Phase Systems
  - Lines showing sustained performance
  - Proactive process of corrective action
- ▶ Water Injection Systems
  - Well line PW and SW systems improving
    - Caution - SW system limited/preliminary data
  - Flow line water injection
    - Coupon program showing improvement
    - Discrepancy between coupon and inspection trends

### ▶ External Corrosion

- ▶ On track to deliver 35,000 locations in 2003
- ▶ Cased pipe baseline inspection on-track for completion by end 2003

### ▶ Y-36 Spill and Followup Actions

- ▶ Significant increase in cased pipe effort

Oct 2003

BP/ADEC Meet and Confer VI

31

CPA

28 April 2003

# ConocoPhillips

## Commitment To Corrosion Monitoring Overview

presented to the

*5<sup>th</sup> Meet & Confer*

April 2003

Corrosion is Under Control on Phase Production Lines

2002

- ✓ Over 30,000 ft of over 233 lines inspected (RTR and RT)
- ✓ Integrated Turbulent Area Inspection Program
- ✓ 0 Leaks, 0 Saves
- ✓ Smart Pig of water lines >10" – Cost Prohibitive, evaluating alternatives

↘ \*100K just for smart pig (not including catfish)  
↓

**Internal Corrosion Spills  
- Cross Country Lines**  
1994 Spill 24" 1Y/R Crude CC Line

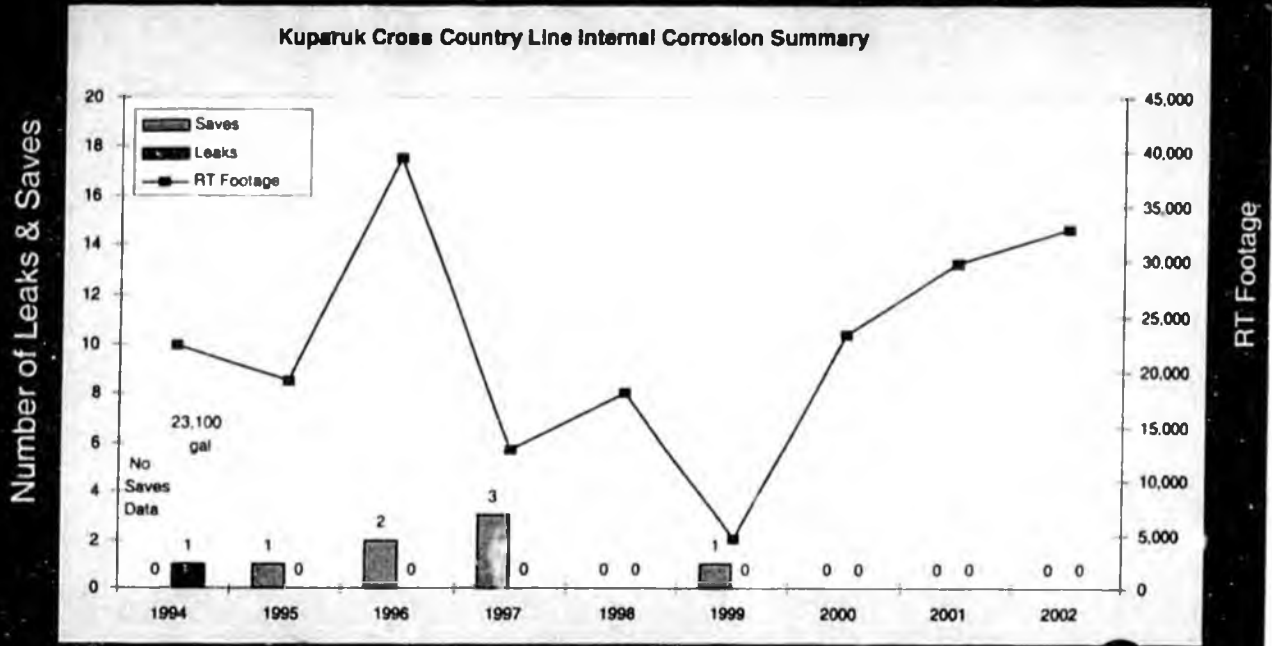

Internal Inspection Focus Area

- ✓ Completed goal of inspecting all .312" lines due for inspection
- ✓ Over 22,000 ft of over 500 lines inspected (RTR and RT)
- ✓ 17 lines required repair (8 injectors, 9 producers)
- ✓ 2 Leaks, 15 Saves
- ✓ Expanded inspection scope @ DS 2T

2002

Internal Corrosion Spills  
- Well Lines

1998 Spills: 1L-1 6" WI  
1L-3 6" WI  
1A-1 6" WI

2000 Spill: 1G-8 6" PC

2002 Spills: 2A-18 6" PC  
2T-13 6" PC

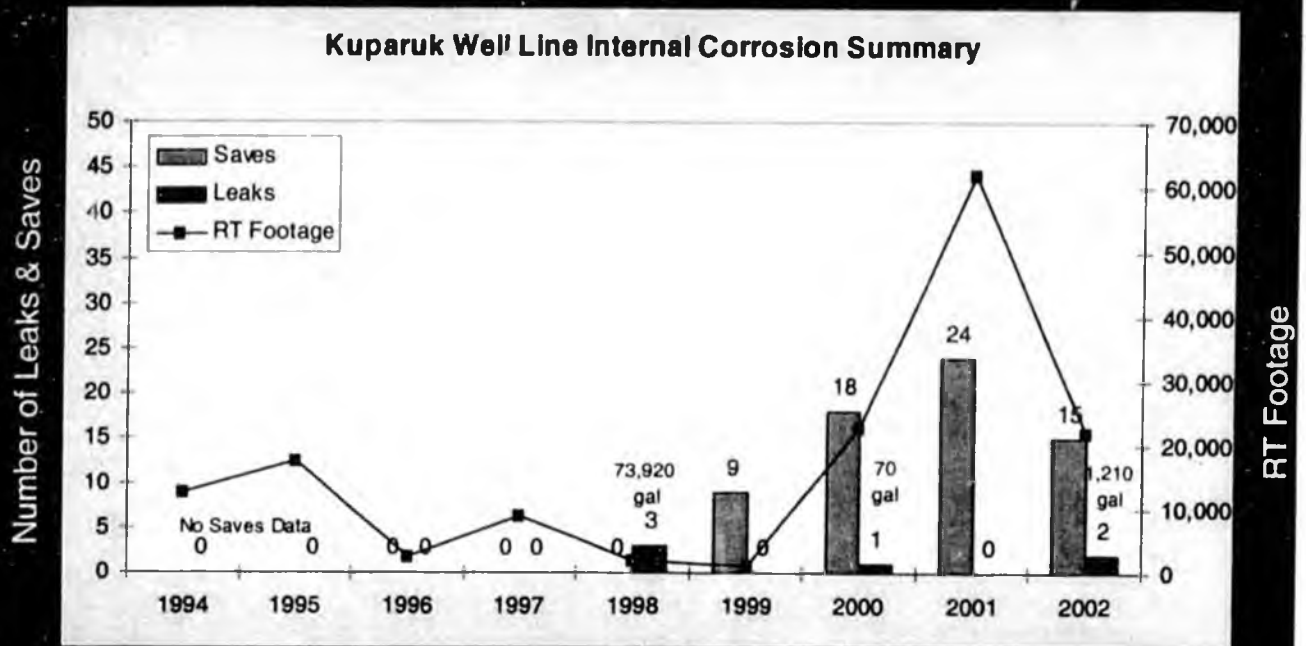

✓ **Continue to Focus on and Inspect Well Lines**

- Complete baseline inspection of 6" OD, .312 and .375 lines six years or older
- Priority based on wall thickness, age of line, and time since previous inspection.

✓ **Maintain Inspection of Cross Country Lines**

- Inspect roughly 15,000+ feet by RTR
- Complete inspection of elevation change elbows scheduled as part of the "Turbulent Area Program" inspections (formerly called "Elbow Inspection Program")
- Prioritize & finalize plan to inspect Water Injection CCL's >10"

Corrosion Inhibition is effective

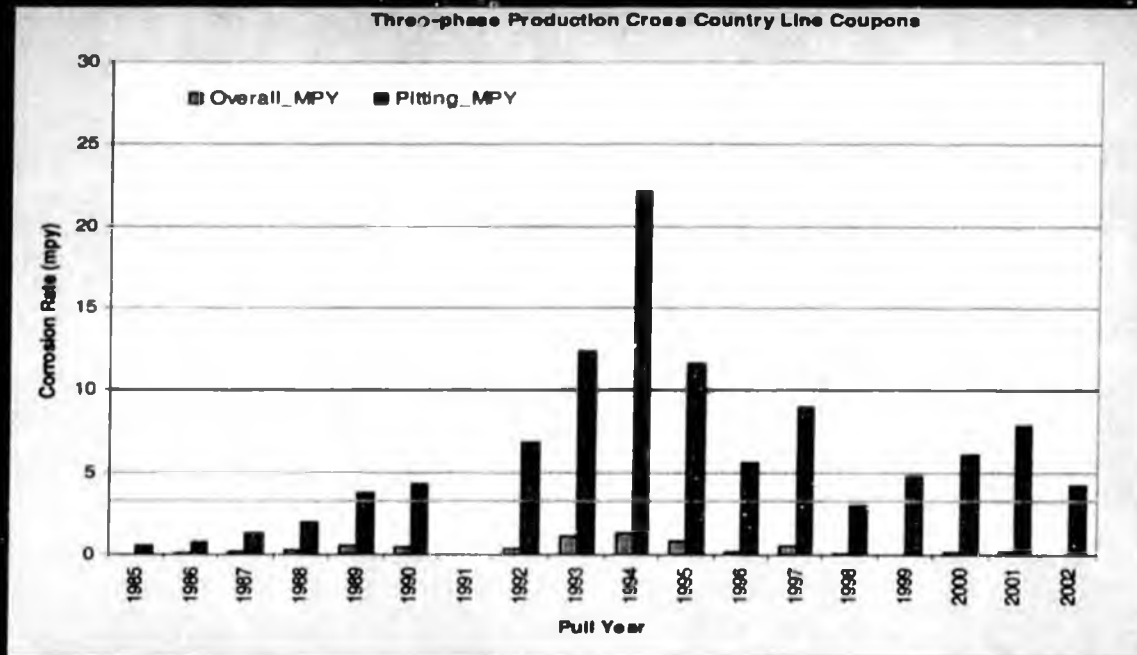

2002

- ✓ Coupon average rates remain below thresholds, and are trending down
- ✓ Over 90% of 3-Phase Production CG lines have ER probe rates < 2 mpy
- ✓ Less than 3% of repeat inspection locations showed increases
- ✓ All inhibited 3-Phase Production CG lines with probe, coupon, or inspection rates above thresholds had corrective action taken

Continuing Focus Area

2002

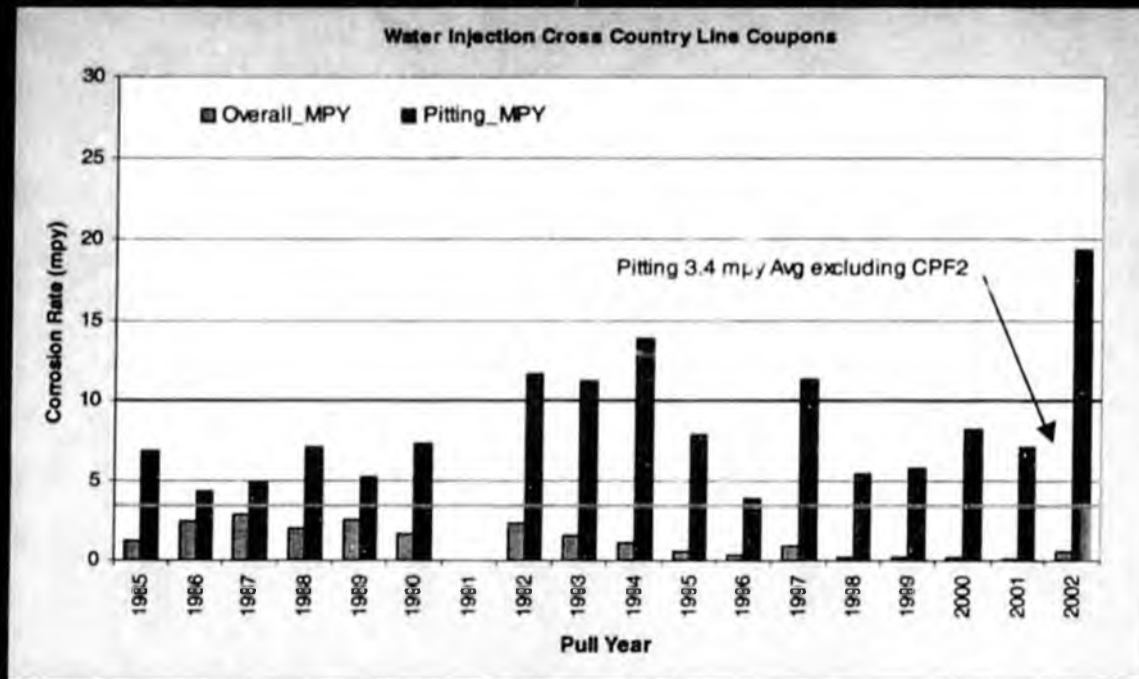

- ✓ Field average pitting rate excluding “bad actors” falls below threshold (Average affected by lines at CPF2)
- ✓ Recent inspection data from the CPF2 lines show some damage on three lines.
- ✓ Investigation into CPF2 PW System anomalies – some corrective steps already taken (i.e. biocide treatment concentration increased)

*batch treatment weekly of biocide @ CPF2*

*47 mpy @ CPF2*

2002

3 Phase Production Well Lines

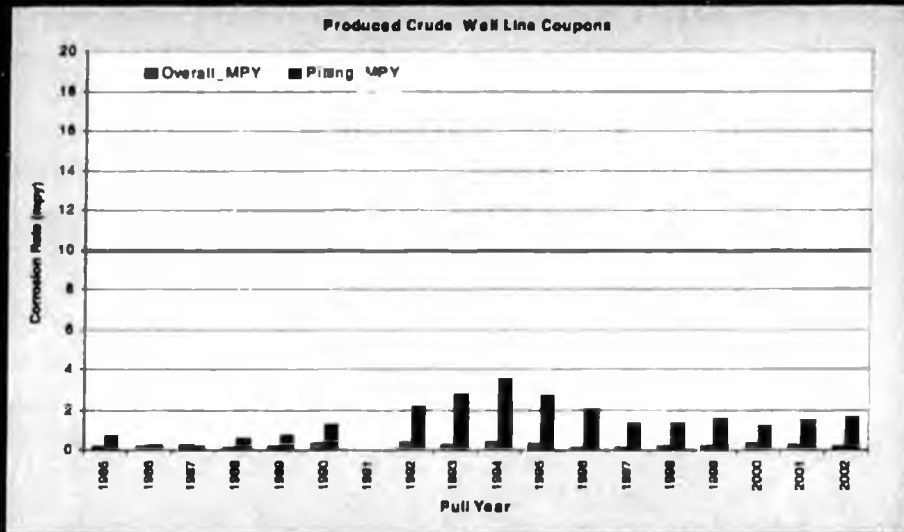

- ✓ Coupon average corrosion rates remain below threshold levels
- ✓ Well head CI injection design selection finalized
- ✓ Well head CI added at selected Tabasco wells & trunk piping

Water Injection Well Lines

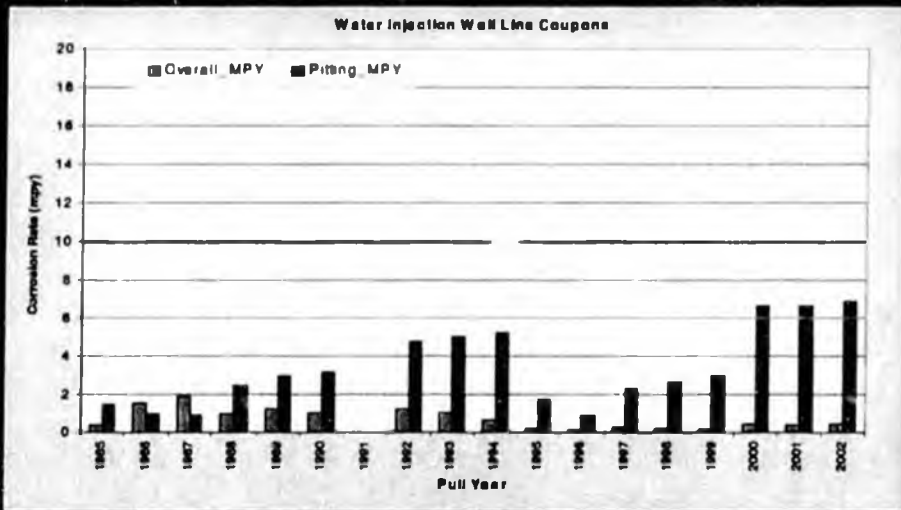

- ✓ Coupon corrosion rates remain below targets
- ✓ Inspection data indicates that higher rates are actually being experienced

2743

- ✓ Continue testing for more effective corrosion inhibitors
  - Field test of Champion 2002-49A underway at DS1R
  - At least two additional field tests candidates targeted
- ✓ Complete Implementation of wellhead corrosion inhibitor injection at at least 4 more Drill Sites
- ✓ Complete initial investigation of CPF2 PW System anomalies
- ✓ SBG (Surfactant) Produced Water System Pilot Test
  - Design stage and chemical formulation complete, planning on mid year start-up at DS1E

✓ Schmoob to engine

DS 74  
now

SBG  
pilot

Need to look at where wellhead injection occurs. (H2I sensor)

Kuparik - replaces insulation w/ tape \*Ted - get the photos and show c

ConocoPhillips

External Inspection

Mature Ongoing Program

2002

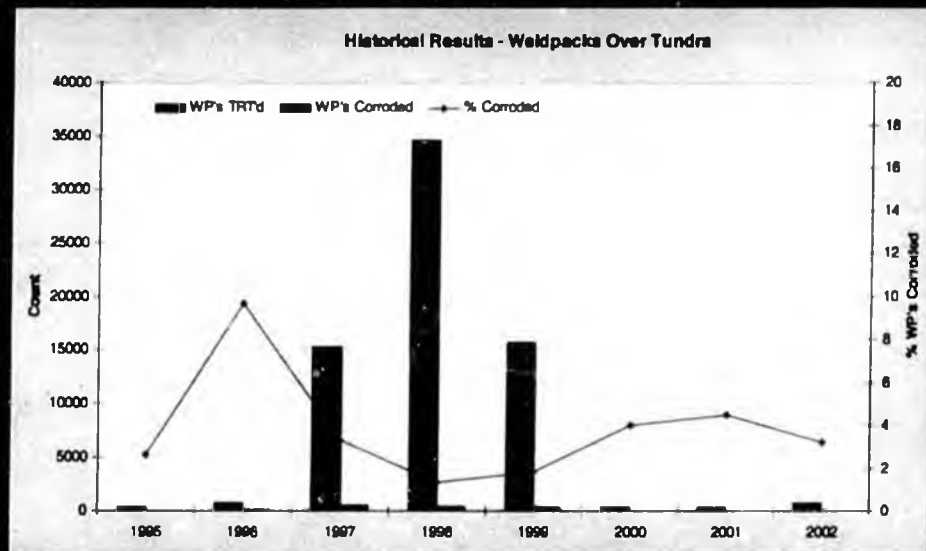

CC Lines Over Tundra

- ✓ Initiated limited scope recur effort
- ✓ Targeted medium-wet weld packs in saddles identified during initial survey.
- ✓ 12% were found with increased water saturation.

CC Lines On Pad

- ✓ Overall program completion - 92%
- ✓ TRT'd 2658 weld packs, 150% of annual goal
- ✓ The % corroded weld packs found dropped slightly, ~ 1.8%

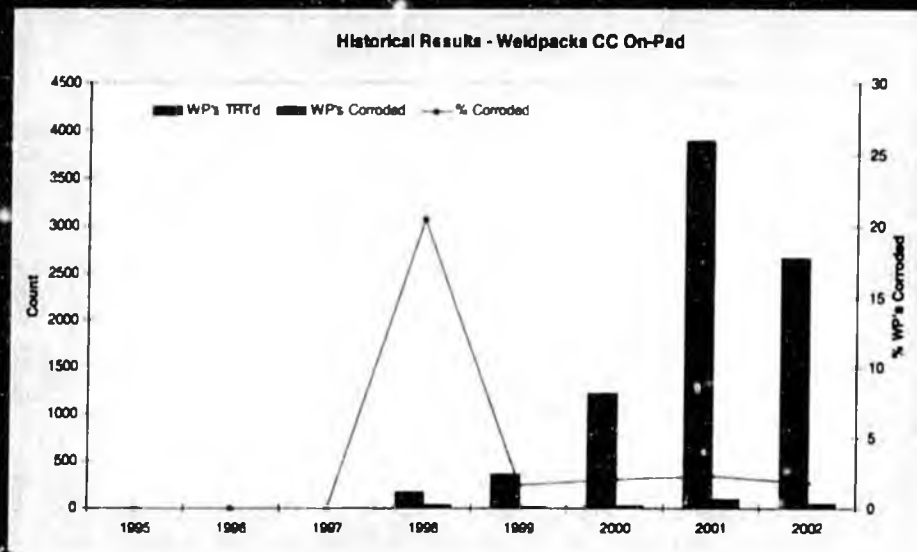

no repair

Continuing to Monitor External Corrosion

- ✓ Overall program completion - 60%
- ✓ Goal is to complete TRT baseline inspections by YE 2005
- ✓ TRT'd 4116 weld packs by YE, 103% of annual goal
- ✓ % Corroded increased to 3.5%
- ✓ Two locations repaired

2002

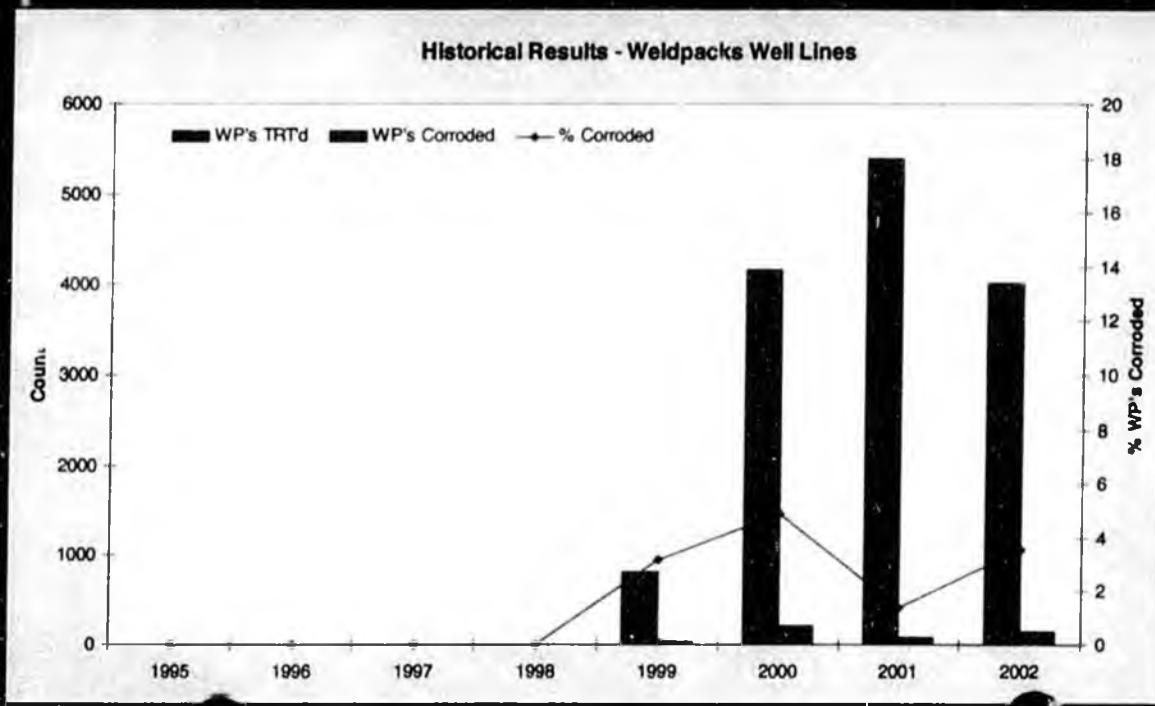

## 2003 Goals

- ✓ Cross-Country Lines Over Tundra
  - Recur TRT approximately 1500 CUI locations
  - TRT approximately 100 'Tarn Design' weld packs
  - Continue monitoring of 'Denso Tape' protocol
  - Develop prioritized long term recur schedule / program
- ✓ Cross-Country On-Pad
  - Inspect 50% of remaining weld packs, with goal of 2004 YE completion
- ✓ Well-Line Weld Packs
  - Inspect 17% of weld packs, with goal of 2005 YE completion
- ✓ Perform initial evaluation of last summer's CUI Buffer Spike pilot program

2002

Completed Goal of Inspecting All Priority 1 Pipes

- ✓ Inspected all 130 previously un-inspected priority 1 locations with PTI/TWI
- ✓ 8 cased pipes were excavated (goal was 5 to 9)
  - 2 had severe to moderate damage (1 internal, 1 external)
  - external damage was sleeved, internal damage was replaced & upgraded
  - 6 had minor or no significant corrosion
- ✓ 8 Refurbishments, 2 Saves, No Leaks
- ✓ Completed Annual Visual Casing Inspection - cleared all obstructions

*Program Snapshot*

Note: The only uninspected priority 1 lines are those that are newer than 10 years old

All Lines in GKA/AOA Inventory	Inspected Thru 10/31/02	Un-inspected Lines	Total	Previously Uninspected Lines Inspected in 2002
Priority 1 Oil	331	44	375	38
Priority 1 Non-Oil	226	17	243	92
Priority 2 Oil	1	18	19	0
Priority 2 Non-Oil	0	98	98	0
Priority 3 Oil	1	21	22	0
Priority 3 lines Non-Oil	2	13	15	0
<b>2002 Total Inventory</b>	<b>561</b>	<b>211</b>	<b>772</b>	<b>130</b>

- ✓ Re-inspect approximately 60 priority 1 pipes
  - Inspect using PTI and/or TWI technologies
- ✓ Complete initial inspection of all priority 2 lines ~ 115 lines
  - Selectively use PTI and/or TWI technologies where warranted.
- ✓ Prioritize and excavate lines as appropriate ~ 5-9 lines
- ✓ Continue cooperative efforts with equipment vendors, COP R&D, and BP to improve technology, and explore new technologies

Summary

2002

### External Corrosion

- ✓ No incidents to report

### Internal Corrosion

- ✓ 2A-18 Well Line Leak at Cosasco Fitting/Elbow (4/7/02); previously reported
- ✓ 2T-13 Well Line Leak (7/25/02)

### Other Structural

- ✓ No incidents to report

3T-2T-13 PO Well Line Leak 7-25-02

- Leak occurred shortly after shutting-in well at manifold building
- 10 gallons of product (41% oil and 59% produced water) spilled, contained on-pad
- Leak occurred in 0.375" wall thickness section of line at a weld pack
- Completion of investigation delayed due to lack of access

Background Inspection History:

- Pre-spill inspections on this line consisted of:
  - weld-packs
  - branch connections (part of 2A-18 follow-up inspections)
- Piping was originally installed at DS 3R, then reclaimed for use at 2T-13 in 1996
  - Pipe was new when installed and abandoned at DS 3R
  - Condition of pipe when installed at 2T-13 in 1996 is unknown
- Based on age (6 years) and wall thickness of 0.375", this section was not scheduled for initial internal inspection until 2004.

*Inspection unknown*  
↓

Activity/Phase

6" 2T-13 PO Well Line Leak

7/25/02

- Evaluate replacement line size for well 2T-13 to minimize under deposit corrosion
  - ✓ **Complete** (4" piping installed)
- Inspect all well lines at DS 2T for internal corrosion, to determine if similar conditions exist
  - ✓ **Complete** - inspected 34 well lines at DS 2T.
    - 28 well lines showed no corrosion damage
    - 6 well lines showed much less severe damage, similar to 2T-13 mechanism
    - 1 well line (2T-08) met "Best Practice" (not derated) repair criteria.
  - ✓ Additionally, inspected 6 of all DS 3R well lines (origin of pipe used on DS 2T)
    - No significant damage was noted on any of the DS 3R well lines.
- Based on inspection results, determine if inspection criteria across field should be modified
  - ✓ 20 lines, with similar design and operating conditions as 2T-13, were added to the 2003 inspection schedule
  - ✓ Continuing to verify conclusion that severity of 2T-13 corrosion was an isolated incident.
    - All prior inspection results continue to support current program criteria

put in service in 1986

ConocoPhillips

Spills/Incidents

# 2003 Update

## Scenario:

- On 4/14/03 at 7:00 a.m., a leak from a small ¼ inch hole was discovered on an 8 inch Cross-Country Seawater Injection line located approximately 300 feet off the Kuparuk CPF3 pad.
- The leak was discovered during a normally scheduled visual inspection.
- Estimated 135 BBL of sea water was spilled, contacting an area of tundra approximated by a circle 75 feet in diameter.

Seawater and produced water service

8" 3B Seawater Line Leak

4/14/03

- In 1999, 274 weld packs were inspected for Corrosion Under Insulation
  - 3 weld packs were stripped and refurbished, no repairs required
- In 1999, two internal corrosion areas identified, 30% and 25% wall loss.
- In 12/2001, recurring internal inspection at 30% location showed no increase.
- On 7/28/2002, recurring internal inspection showed minor area increase, and 31% wall loss.
- In 1<sup>st</sup> Qtr 2003, scheduled RTR internal corrosion crawler showed 'F' rated damage at several internal locations near welds.
  - Worst damage was 73% wall loss.
  - Recommendation to shutdown and depressure the line was issued.

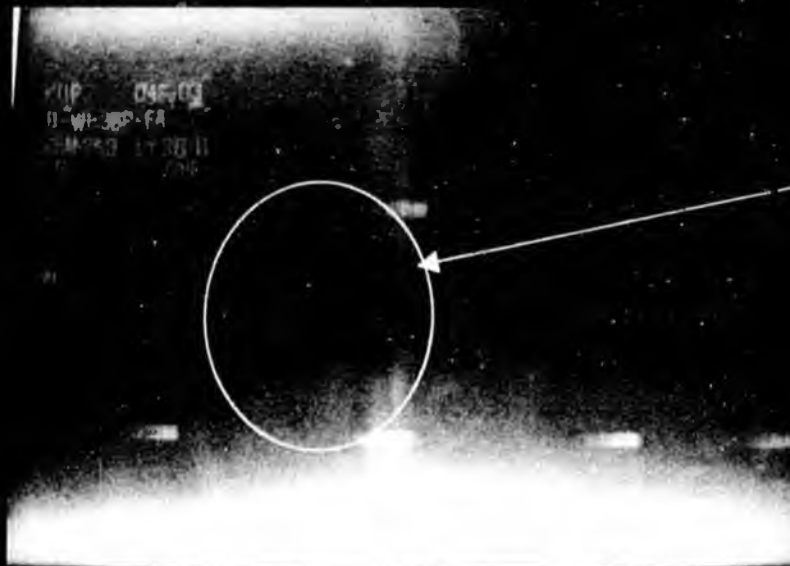

typical Internal corrosion found near welds on 8 in. Line  
- not a film of actual leak site.

**Equipment Classification:**

**Well Line** – Pipe from the wellhead to the Drill Site manifold. For production wells, a well line handles the flow from a single well prior to commingling with fluids from other wells and transportation to the Central Processing Facility. For water injection wells, a well line handles the water flow going from a common manifold to a single wellhead.

**Cross-Country Line** – Pipe from the Drill Site manifold to the Central Processing Facility (CPF).

**Below-Grade Location** – That portion of a single pipeline, which crosses underneath a road or other earthen feature at a single location. The linear extent of the location consists of the length of pipeline between casing ends.

**Service Definitions:**

**Three-phase Production** – Basic reservoir fluids (oil, water, and gas) produced from down hole through to the CPF. Typically sees changes in temperature and pressure only from reservoir changes and are essentially un-separated.

**Seawater (SW)** – Water from the Beaufort Sea that has been treated at the Seawater Treatment Plant (STP). Note that seawater treatment at the Kuparuk STP consists of filtration, oxygen stripping using produced gas, and biociding.

**Produced Water (PW)** – The water separated at the CPF from three-phase production.

**Mixed Water (MW)** – Produced water and seawater that have been commingled.

**Gas** – Generic term for the different gas systems that transport dry (no liquids) gas between facilities. Includes fuel gas, artificial lift gas, and miscible Injectant.

**Produced Oil** – The liquid hydrocarbon separated at the CPF from three-phase production.

**Inspection Terminology:**

**CRM** – Corrosion rate monitoring.

**UT** – Ultrasonic testing

**RT** – Radiographic testing

**RTR** – Real time radiographic testing

**TRT** – Tangential radiographic testing

**PTI** – Profile Technologies Inc. (Electro magnetic inspection)

**TWI** – The Welding Institute (Long range UT)

**KDR** – Known damage recur inspection

# ConocoPhillips

## Commitment To Corrosion Monitoring Overview

presented to the  
Alaska Department of Environmental Conservation  
*6<sup>th</sup> Meet & Confer*

October 30, 2003

2003

- ✓ Over 38,000 ft of over 198 lines inspected (RTR and RT)
- ✓ On schedule to complete baseline inspection on elbows due for inspection under our Turbulent Flow Area Inspection Program
- ✓ 1 Leak (injector), 3 Saves (1 injector, 2 producers)
- ✓ Linear Array appears to work on 16" and smaller water packed lines.

**Internal Corrosion Spills  
- Cross Country Lines**  
 1994 Spill 24" 1Y/R Crude Oil  
 2003 Spill 8" 3B Sea Water

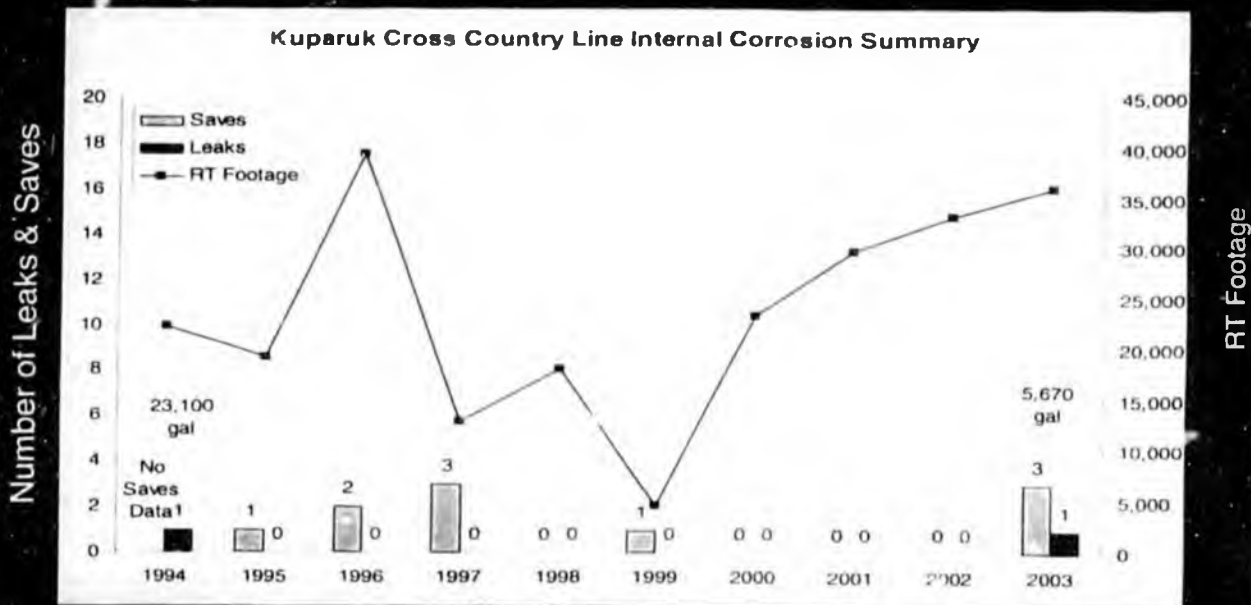

2003

*going to reassign insp time*

- ✓ On schedule to complete baseline inspection of all well lines due for inspection
- ✓ Over 13,000 ft of over 469 lines inspected (RTR and RT) so far.
- ✓ 21 lines required repair (17 injectors, 4 producers)
- ✓ 0 Leaks, 21 Saves

**Internal Corrosion Spills - Well Lines**

1998 Spills	1L-1 6" WI
	1L-3 6" WI
	1A-9 6" WI
2000 Spill	1G-8 6" PC
2002 Spills	2A-18 6" PC
	2T-13 6" PC

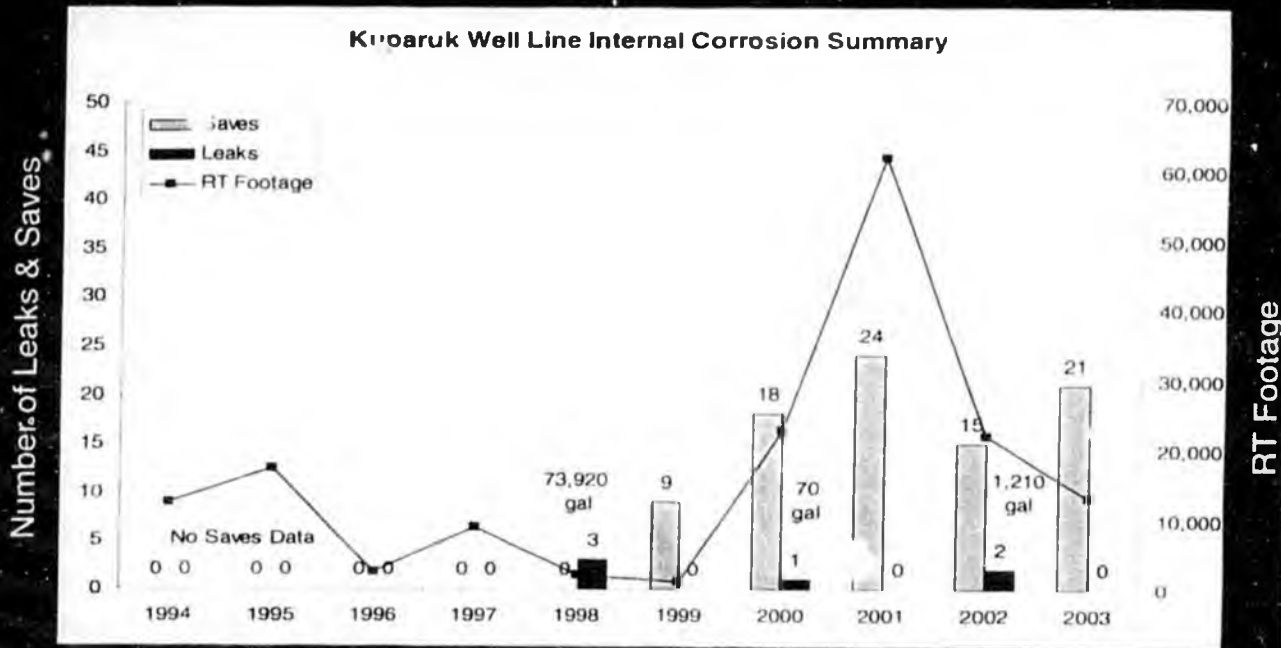

*Under direct corrosion - SRBs are major cause*

*Increased corrosion from 1st to 2nd lines*

<b>Cross-Country Lines</b>	
<i>Goal</i>	<i>Status</i>
Inspect ~ 15,000 feet by RTR.	Inspected 38,000 feet
Complete elevation change elbow inspections	On schedule to complete
Prioritize and finalize plan to inspect WI lines >10" OD.	List compiled, Finalizing '04 plan.
<b>Well Lines</b>	
Complete baseline inspection of all 6" OD, 0.312 and 0.375" six years old or older or since previous inspection.	On schedule to complete

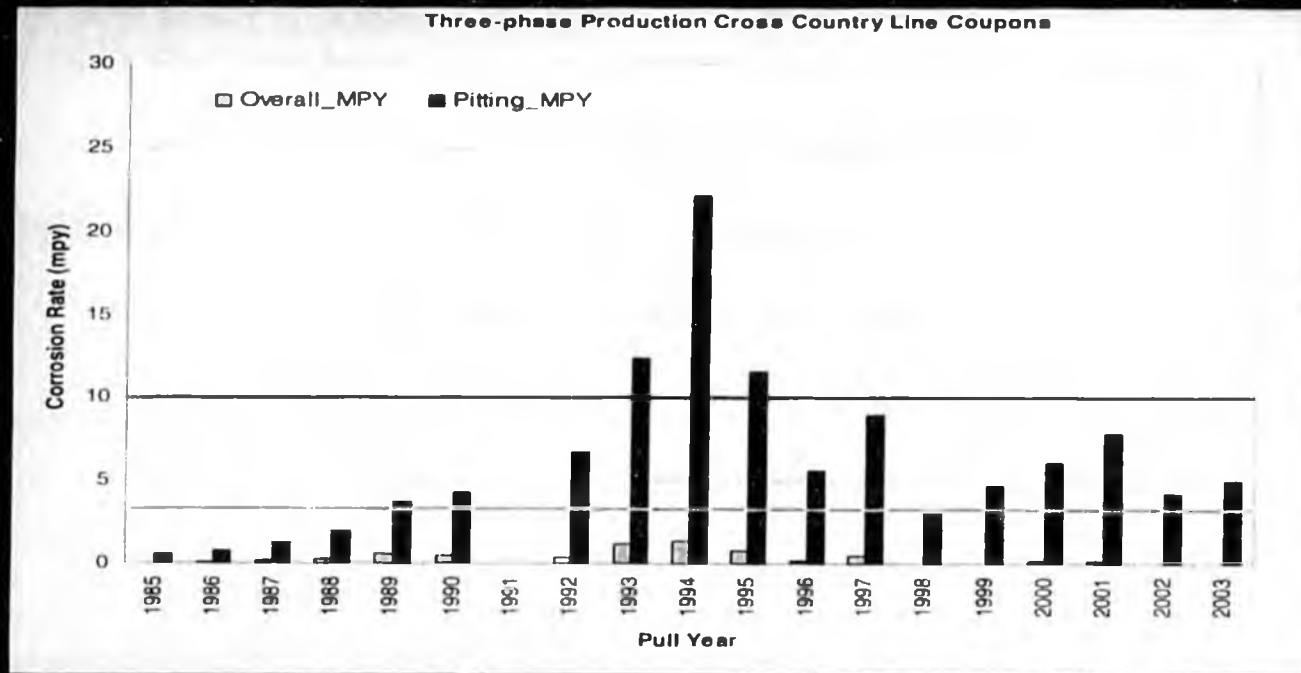

2003

- ✓ Coupon average rates remain below thresholds
- ✓ 95% of 3-Phase Production CC lines have ER probe rates < 2 mpy
- ✓ 3% of repeat inspection locations showed increases
- ✓ All inhibited 3-Phase Production CC lines with probe, coupon, or inspection corrosion rates above thresholds had corrective action taken

2003

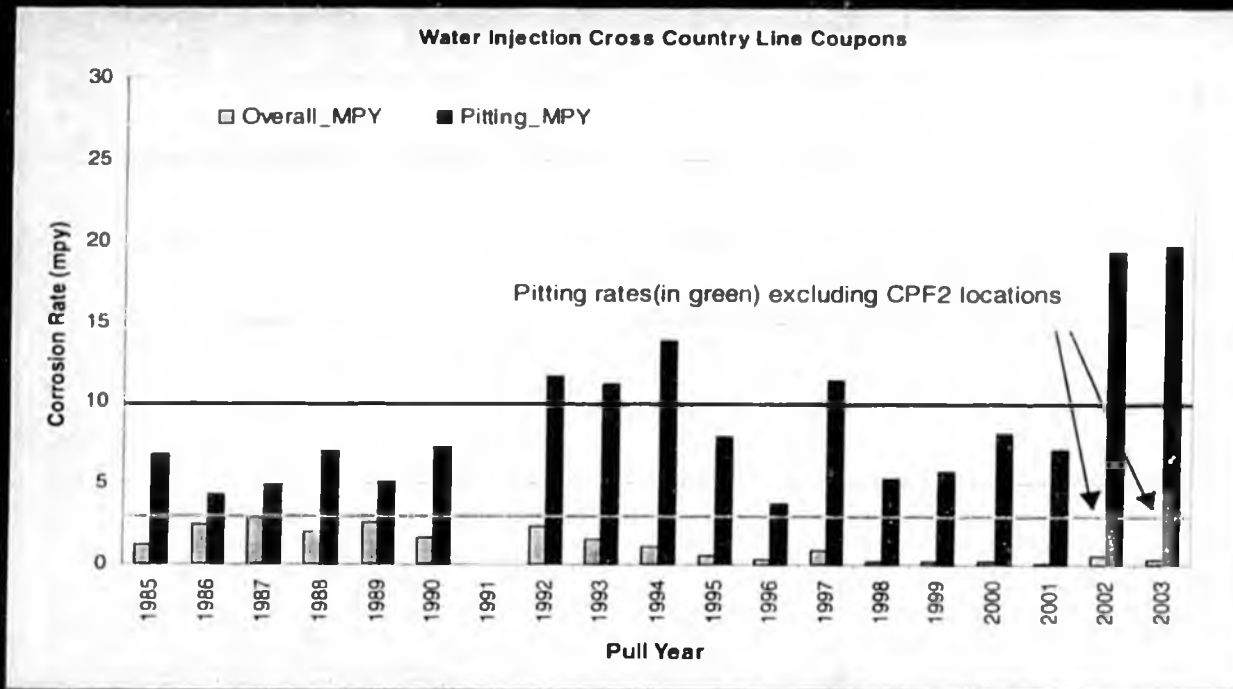

- ✓ Average corrosion rates affected by lines at CPF2.
- ✓ Since 2001, all 16 CPF2 CC WI lines under 12" dia. inspected with RTR. Two lines showed damage greater than 30% wall loss using UT.
- ✓ Biocide study completed and formal recommendations implemented at CPF2 and in progress at other two CPF's.

*Coupons located in area - 10/10/03*

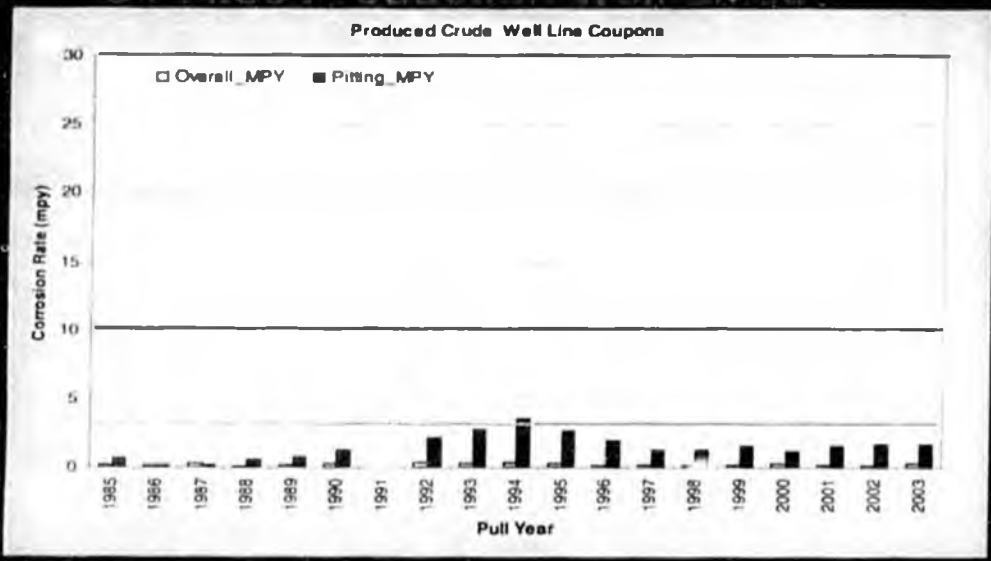

- ✓ Coupon average corrosion rates remain below threshold levels
- ✓ Well head Cl injection being installed at DS's 2T, 1H, 1A, 1Y

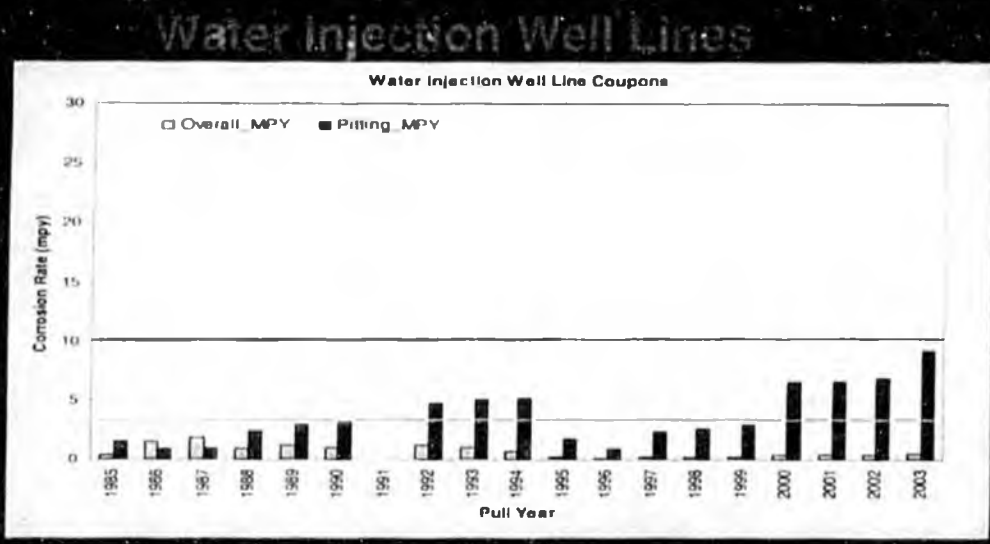

- ✓ Coupon average corrosion rates remain below targets
- ✓ Inspection data indicates higher corrosion rates in some lines
- ✓ KDR locations are identified

*Handwritten notes:* V. ...

Monitoring & Mitigation	
Goal	Status
Continue testing for more effective corrosion inhibitors	<ul style="list-style-type: none"> <li>• Field test of Champion 2002-049A completed at DS1R. Next test planned for 2UVW system in November</li> <li>• Field test of Champion 2002-050B pending at DS1R. Evaluation of another field test candidate in progress.</li> </ul>
Complete Implementation of wellhead corrosion inhibitor injection at 4 more Drill Sites	<ul style="list-style-type: none"> <li>• DS's 1A, 1H, 1Y, 2T engineering and construction in progress</li> <li>• Added chemical tech position to perform system maintenance</li> </ul>
Complete initial investigation of CPF2 PW System anomalies	<ul style="list-style-type: none"> <li>• Biocide study completed</li> <li>• Recommendations are being implemented</li> </ul>
SBG (Surfactant) Produced Water System Pilot Test	<ul style="list-style-type: none"> <li>• Hardware installed, remaining work in progress</li> </ul>

2003

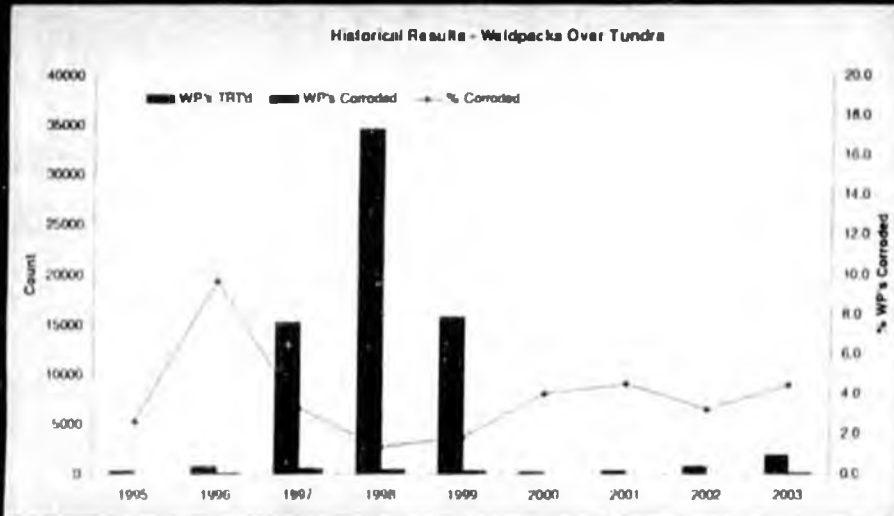

- ✓ 1864 weld packs TRT inspected. 83 had corrosion or ~5%. No repairs.
- ✓ Walkdown verification underway
- ✓ Approx. 1,000 weld packs identified so far that need baseline inspection.

CC Lines On Pad

- ✓ Overall program completion - 96%
- ✓ 352 weld packs TRT'd YTD (long weld packs, high)
- ✓ The % corroded weld packs found increased to 5.1%. No Repairs

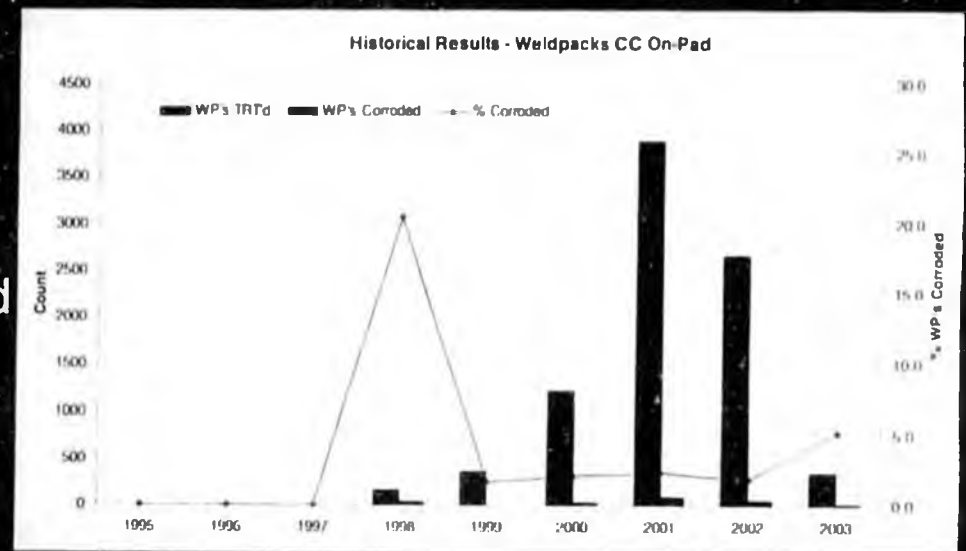

*Completed baseline 2005*

2003

- ✓ Overall program completion - 77%
- ✓ Annual goals for 2003, 2004, and 2005 revised to 2,500.
- ✓ 2358 weld packs TRT'd YTD
- ✓ % Corroded decreased to 1.5%
- ✓ Two locations repaired

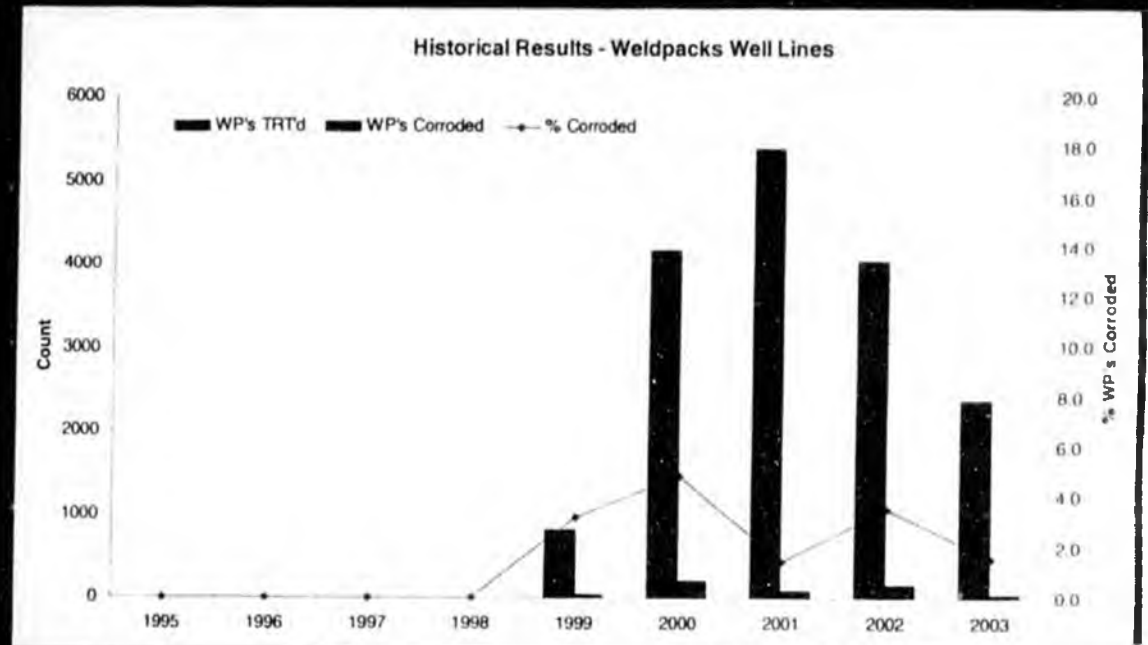

## Buffer Spike Summary

- pH data was obtained on all test locations.
- Field review of this data indicates that the pH increased substantially in the wet insulation.
- The 2003 progress report has not yet been completed.
- TRT of the test locations planned for 2004

**Cross-Country Lines Over Tundra**

<b>Goal</b>	<b>Status</b>
Complete walk down verification of 172 high priority lines.	Have completed 140 lines YTD, 81%
TRT approx. 100 'Tarn Design' WPs	<b>Complete:</b> 100 WPs were inspected using C-arm. No water was found.
Continue monitoring of 'Denso Tape' refurb. technique	Continued spot checks of locations. No failures found
Develop long term recur schedule/program	In progress. Gathering inspection data.
<b>Cross-Country On-Pad</b>	
Inspect 50% of remaining WPs (343) with goal of 2004 YE completion of baseline inspections	<b>Complete:</b> 352 WPs TRT'd YTD
<b>Well Line Weld Packs</b>	
Inspect 17% of weld packs, 2005 completion	Goal revised to 2500. 2358 WPs TRT'd YTD; on track for 2005 completion
<b>Misc.</b>	
Evaluate last summer's CUI Buffer Spike pilot program	Pending final report from B'ville

2003

- ✓ Re-inspected 82 priority 1 locations with PTI/TWI
- ✓ Inspected all priority 2 locations
- ✓ 6 cased pipes excavated so far (goal was 5 to 9)
  - One had severe internal damage - pipe was replaced
  - One had moderate internal damage - scheduled for replacement in 2004
  - Four had only minor or no significant corrosion
  - Tally so far: 6 Refurbishments, 2 Saves, No Leaks
- ✓ Completed Annual Visual Casing Inspection - cleared all obstructions

*Program Snapshot*

Note: The only uninspected priority 1 lines are those that are newer than 10 years old

All Lines in GKA/AOA Inventory	Inspected Thru 10/31/03	Un-inspected Lines	Total	Previously Uninspected Lines inspected in 2003
Priority 1 Oil	327	40	367	0
Priority 1 Non-Oil	236	21	257	1
Priority 2 Oil	14	1	15	0
Priority 2 Non-Oil	84	0	84	0
Priority 3 Oil	3	26	29	0
Priority 3 lines Non-Oil	1	22	23	0
<b>2002 Total Inventory</b>	<b>665</b>	<b>110</b>	<b>775</b>	<b>1</b>

2003 Goals - Status Update

<b>Goal</b>	<b>Status</b>
Reinspect ~ 60 priority 1 pipes using PTI/TWI.	Inspected 82.
Complete baseline inspection of all ~ 115 priority 2 pipes using PTI/TWI selectively where warranted	Completed visual and casing gas analysis on all pipes, no PTI/TWI inspections warranted.
Prioritize and excavate 5-9 pipes.	Completed 6 excavations so far.
Continue cooperative effort with equipment vendors, COP R&D and BP to improve current technology and explore new technologies.	B&E tested in '03. Found no reason to switch to this technology at this time.

Summary

2003

**External Corrosion**

✓ No incidents to report

**Internal Corrosion**

✓ No new incidents to report since April meeting

*Matt Collins*

*Fr. H. H. H.*

- 13 pipeline supports failed – Attributed to fatigue
- No breach or reduction of pipeline integrity
- Pipeline support reinstated successfully w/o incident
- Best practices captured & implemented
- Field-wide inspections for similar installations complete
- All support installations surveyed confirmed fit-for-service

*View Report: 1/11/10 11:00 AM*

ConocoPhillips

**THE END**

**Equipment Classification:**

**Well Line** – Pipe from the wellhead to the Drill Site manifold. For production wells, a well line handles the flow from a single well prior to commingling with fluids from other wells and transportation to the Central Processing Facility. For water injection wells, a well line handles the water flow going from a common manifold to a single wellhead.

**Cross-Country Line** – Pipe from the Drill Site manifold to the Central Processing Facility (CPF).

**Below-Grade Location** – That portion of a single pipeline, which crosses underneath a road or other earthen feature at a single location. The linear extent of the location consists of the length of pipeline between casing ends.

**Service Definitions:**

**Three-phase Production** – Basic reservoir fluids (oil, water, and gas) produced from down hole through to the CPF. Typically sees changes in temperature and pressure only from reservoir changes and are essentially un-separated.

**Seawater (SW)** – Water from the Beaufort Sea that has been treated at the Seawater Treatment Plant (STP). Note that seawater treatment at the Kuparuk STP consists of filtration, oxygen stripping using produced gas, and biociding.

**Produced Water (PW)** – The water separated at the CPF from three-phase production.

**Mixed Water (MW)** – Produced water and seawater that have been commingled.

**Gas** – Generic term for the different gas systems that transport dry (no liquids) gas between facilities. Includes fuel gas, artificial lift gas, and miscible Injectant.

**Produced Oil** – The liquid hydrocarbon separated at the CPF from three-phase production.

**Inspection Terminology:**

**CRM** – Corrosion rate monitoring.

**UT** – Ultrasonic testing

**RT** – Radiographic testing

**RTR** – Real time radiographic testing

**TRT** – Tangential radiographic testing

**PTI** – Profile Technologies Inc. (Electro magnetic inspection)

**TWI** – The Welding Institute (Long range UT)

**KDR** – Known damage recur inspection

FALL 2003

30<sup>th</sup> 30.50.3

## **Commitment to Corrosion Monitoring**

**30 October 2003  
10:00 am to 3:00 pm**

**ConocoPhillips Building 700 "G" Street  
Conference Room ATO-1167**

**2<sup>nd</sup>-Half 2003 Meet and Confer  
(Meeting # 6)**

### Agenda

Introductions/Opening Remarks – (10:00 to 10:30 am)

- ConocoPhillips new staffing
- ADEC update on new staffing for Charter
- BP new staffing

BP Review (10:30 to 11:45 am)

Lunch in ATO-1167 (11:45 am to 12:45 pm)

ConocoPhillips Review (12:45 to 2:00 pm)

ADEC (2:00 to 2:30pm)

Open discussion, questions, and feedback (2:30 to 3:00 pm)

BP



**BP and State of Alaska Charter Agreement**  
**Corrosion Monitoring Review 2003**  
**Meet and Confer VI**

**October 30<sup>th</sup>, 2003**



**Outline**

- ▶ **Corrosion Monitoring**
  - » 3 Phase Production
    - Flow line and well line coupons
  - » Water Injection System
    - Flow line and well line
- ▶ **Internal Inspection**
  - » 3 Phase
  - » Water injection
- ▶ **External Corrosion**
- ▶ **Cased Piping Inspection**
- ▶ **Smart Pigging Activity**
- ▶ **2003 Corrosion Related Spills**
  - » Y-36 incident and follow-up
- ▶ **Summary**

## Corrosion Monitoring 3 Phase Production



- ▶ **Weight Loss Coupons**
  - ▶ Well lines
  - ▶ Flow lines
- ▶ **Monitoring Corrective Actions**
  - ▶ ER probes and coupons
- ▶ **ER Probe Example**
- ▶ **Corrosion Inhibitor Injection**
  - ▶ Concentration
  - ▶ Water rates
- ▶ **Inspection**
  - ▶ Flow and well line summaries
- ▶ **Inspection Corrective Actions**
- ▶ **3 Phase Inhibition Summary**

Oct 2003

BP/ADEC Meet and Confer VI

3

## 3 Phase – Well Line Coupons

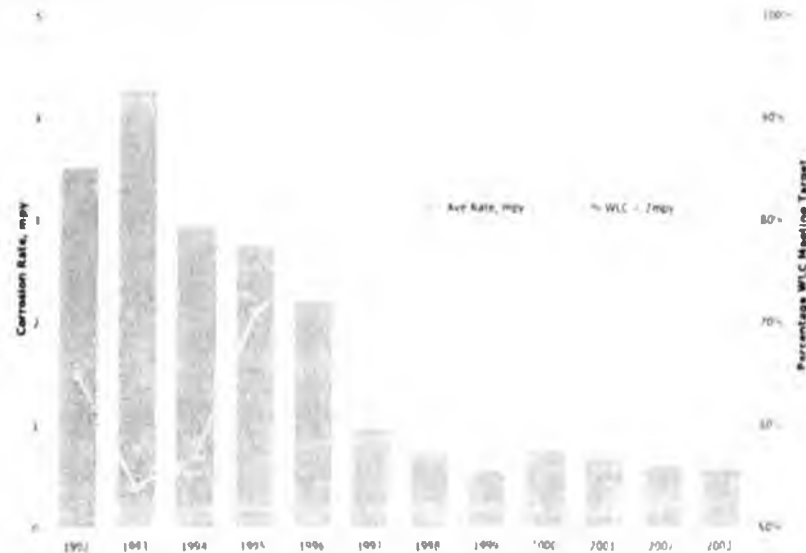

Oct 2003

BP/ADEC Meet and Confer VI

4

### 3 Phase- Flow Line Coupons

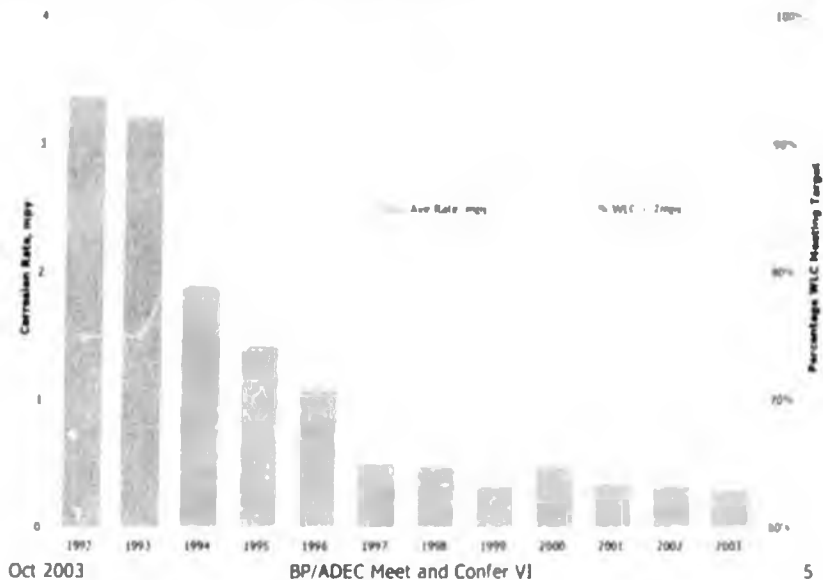

*Confidence intervals/flucts*

### 1997 Onward- Corrosion Rate Focus

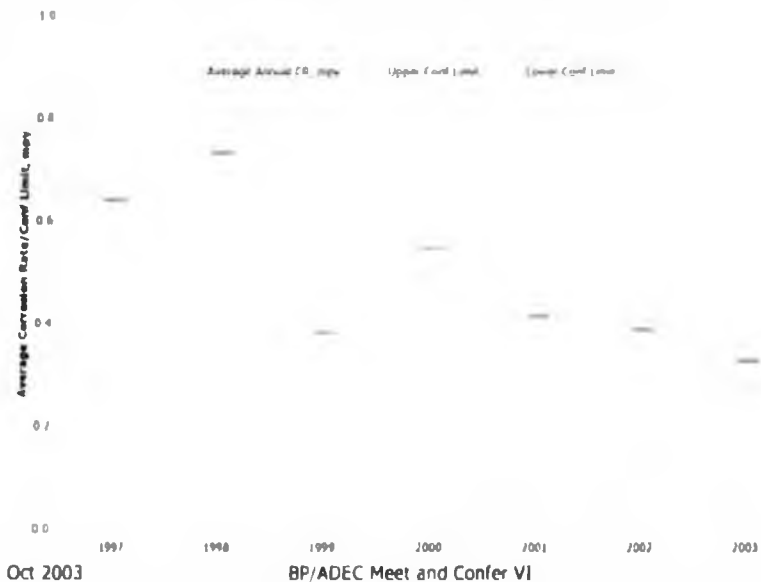

*actions  
lead to cleaner  
lines*

## Flow Line Monitoring Corrective Actions



### ER Probes

	No.	Equip ID
» Action	6	01D
» Action	3	03D
		Y-36
» Action	1	01C
		05D
		17D
		F-49
		16D

Equip ID	Cause	Action
03D	Increased Corrosivity	Increased CI by 6 gpd
05D	Increased Corrosivity	Increased CI by 25 gpd
17D	Increased Corrosivity	Increased CI by 5%
01D	Increased Corrosivity	Increased CI by 5%
03D	Increased Corrosivity	Increased CI by 10%
01D	Increased Corrosivity	Increased CI by 5%
01D	Increased Corrosivity	Increased CI by 5%
01D	Increased Corrosivity	Increased CI 18 gpd
01D & 01C	Increased Corrosivity	Increased CI by 5%
01D	Increased Corrosivity	Increased CI by 10%
03D	Increased Corrosivity	Increased CI by 5%
F-49	Increased Corrosivity	Increased CI by 5%
16D	Increased Corrosivity	Increased CI by 5%
Y-36	Increased Corrosivity	Increased CI by 10%
Y-36	Increased Corrosivity	Increased CI by 10%
Y-36	Increased Corrosivity	Production routing change

### Weight Loss Coupons

Equip ID	Cause	Action
14D	Increased Corrosivity	Increased CI by 10%
Q-01	Increased Corrosivity	Increased CI by ~100%

Oct 2003

BP/ADEC Meet and Confer VI

7

*match up for timing of CI increase*

## ER Probe Corrective Action Example

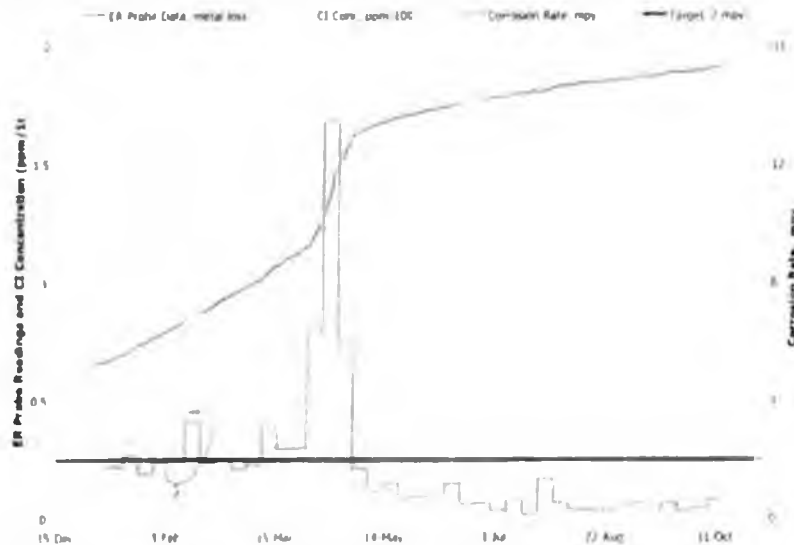

*1D →*

*Location  
downstream  
end*

*changed probe*

Oct 2003

BP/ADEC Meet and Confer VI

8

2 different blends of same CI  
 use  
 of product  
 assess impact  
 represents different methods

## GPB Wide Corrosion Inhibitor Concentrations

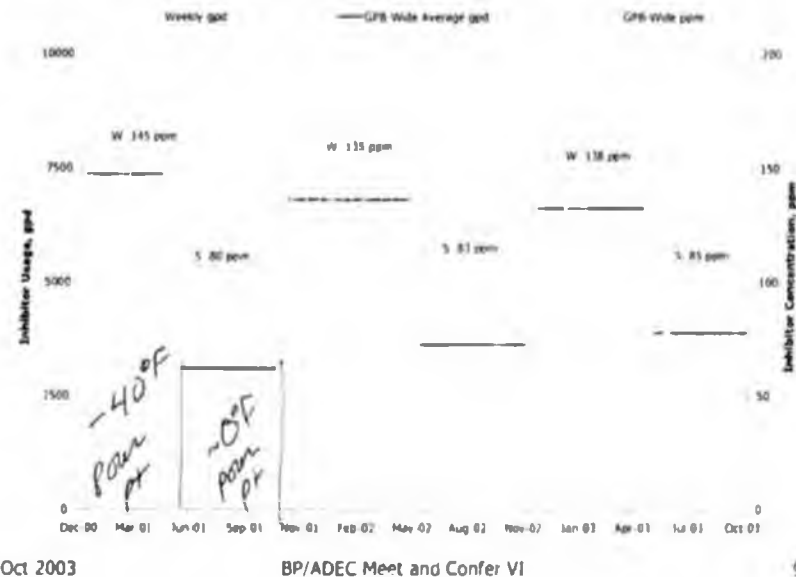

Oct 2003

BP/ADEC Meet and Confer VI

9

## Water Injection Systems

- ▶ **Flow Line Water Injection**
  - ▶▶ Mixed service
- ▶ **Well Line Reporting Format**
  - ▶▶ Single service
  - ▶▶ Service plurality
- ▶ **Weight Loss Coupons**
  - ▶▶ Produced Water system
  - ▶▶ Seawater system
- ▶ **SW Mitigation Update**
  - ▶▶ Oxygen control
  - ▶▶ Biocide and corrosion rate
- ▶ **Inspection**
  - ▶▶ Flow and well line

Oct 2003

BP/ADEC Meet and Confer VI

10

### Aggregate Water Injection Flow Line Coupons

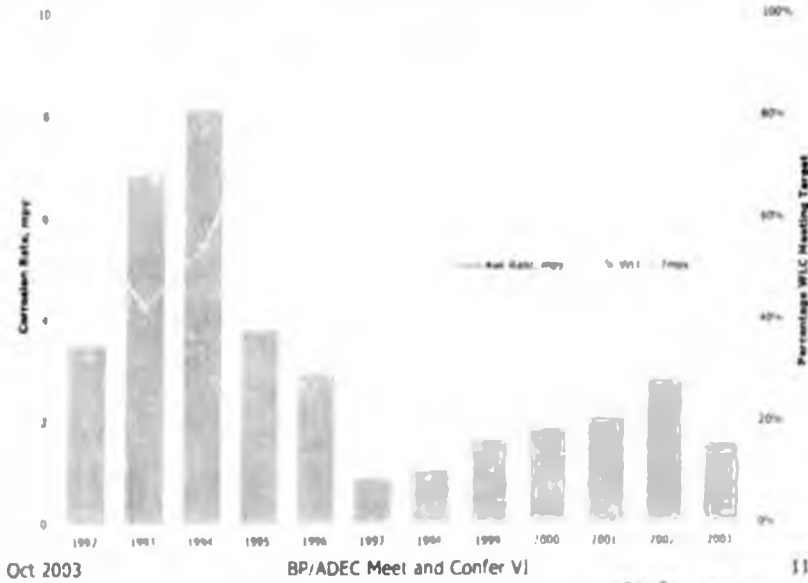

Oct 2003

BP/ADEC Meet and Confer VI

11

*reases*

*due to seawater system*

### PW System- Well Line Coupons

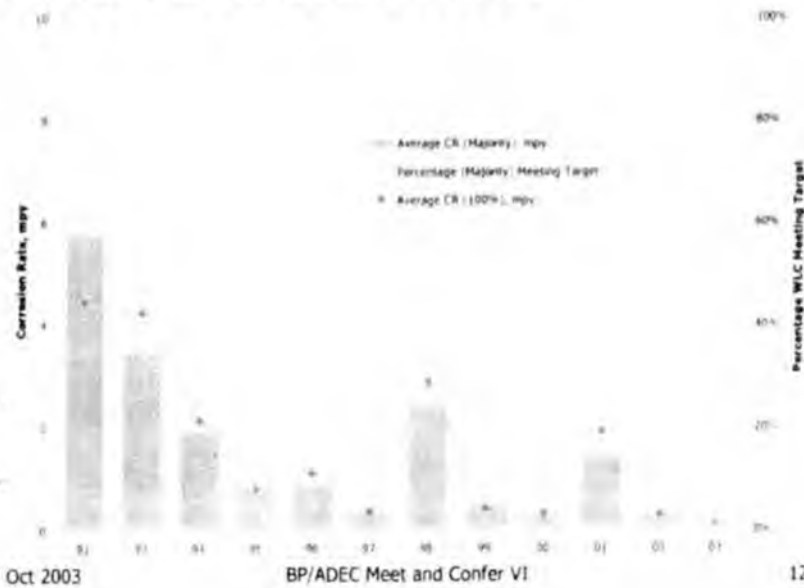

Oct 2003

BP/ADEC Meet and Confer VI

12

*linked data set represents the orange line re: 100% meeting target*

## SW System– 2002/2003 Corrective Actions



- ▶ **Upstream Corrosion Control**
  - ▶ Improved dissolved oxygen control
- ▶ **Downstream Corrosion Control**
  - ▶ Improved microbiological/biocide efficacy
- ▶ **Oxygen Control– Corrective Actions**
  - ▶ Set O<sub>2</sub> control < 20 ppb
    - Mechanical fixes to tower
    - Continuous O<sub>2</sub> scavenger
- ▶ **Microbiological– Corrective Action**
  - ▶ Increased biocide frequency
    - 2002 from once every two weeks to once a week
  - ▶ Increased effective biocide concentration
    - 2003 from 500 ppm to 750 ppm
    - Increases downstream biocide residual levels

Oct 2003

BP/ADEC Meet and Confer VI

13

## SW System– Well Line Coupons

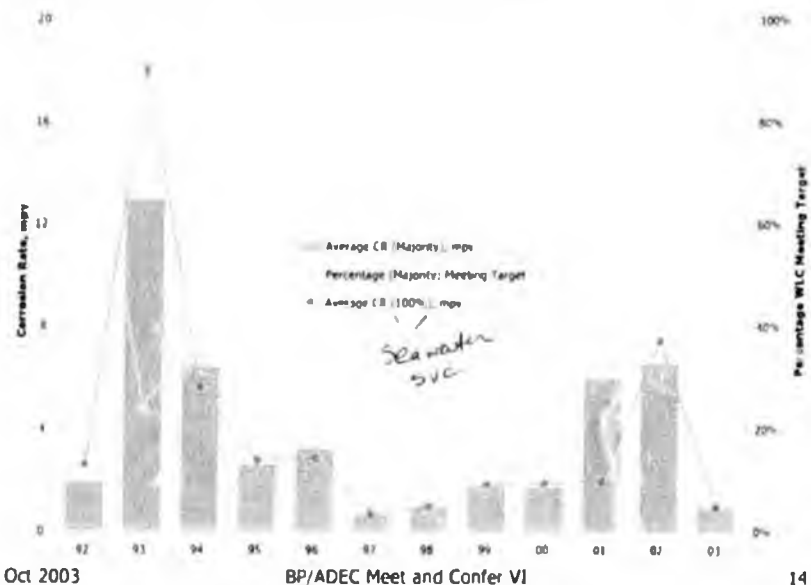

Oct 2003

BP/ADEC Meet and Confer VI

14

*Very limited  
dataset  
system just  
shut  
down  
recently*

*Sub-Contractor in 2003*

## Inspection Program



- ▶ **Inspection Activity**
  - ▶▶ Internal
  - ▶▶ External
- ▶ **Internal Inspection**
  - ▶▶ 3 phase – flow and well line
    - Flow line corrective action
  - ▶▶ Water injection – flow and well line
- ▶ **External Inspection**
  - ▶▶ Activity level
- ▶ **Cased Piping Inspection**
  - ▶▶ Activity level
  - ▶▶ Type and method
- ▶ **Smart Pigging Activity**
- ▶ **Spill Summary**
  - ▶▶ Y-36 Incident

Oct 2003

BP/ADEC Meet and Confer VI

15

## Flow/Well Line Inspection Activity

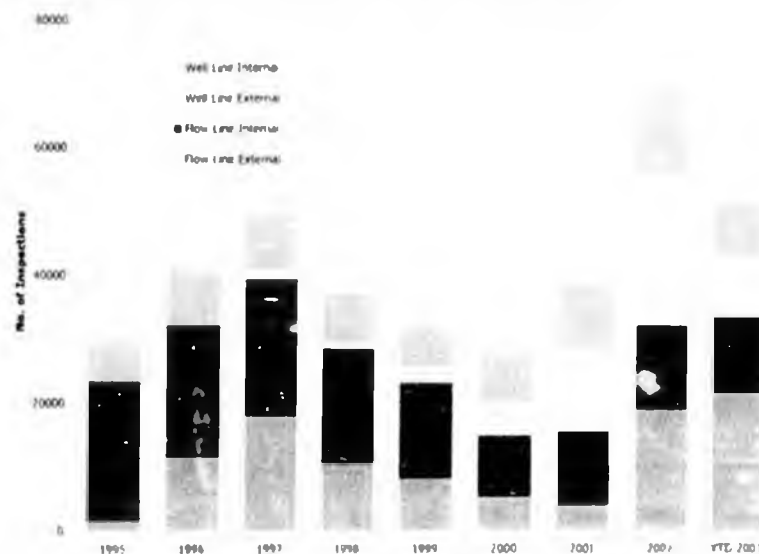

Oct 2003

BP/ADEC Meet and Confer VI

16

*Thru Sept 30*

### 3 Phase Inspection Program

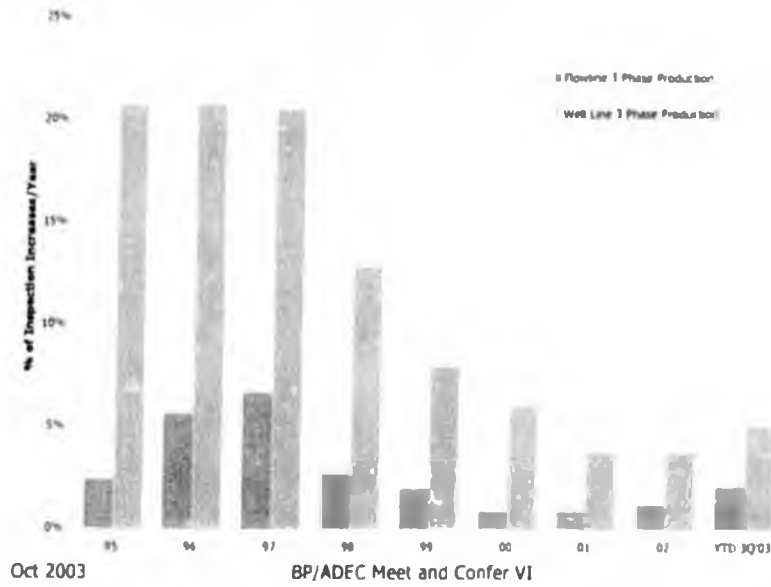

### Flow Line Inspection- Corrective Actions



#### ► Inspection

Equipment ID	Cause	Action
Y36	Increased Corrosivity	See ER Probe Action Log
16C/17C	Increased Corrosivity	Increased CI by 5%
W-74	Increased Corrosivity	Increased CI by 10%

Oct 2003

BP/ADEC Meet and Confer VI

18

## Water Injection Inspection Program

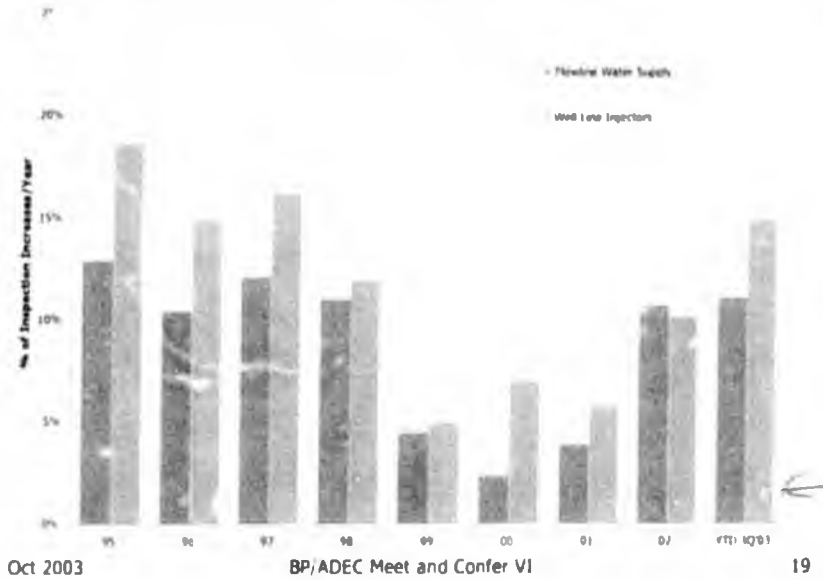

*2 yrs lag time*

*reports change over 2 yrs*

*overlay w/ inspection strategy*

## External Corrosion Inspection

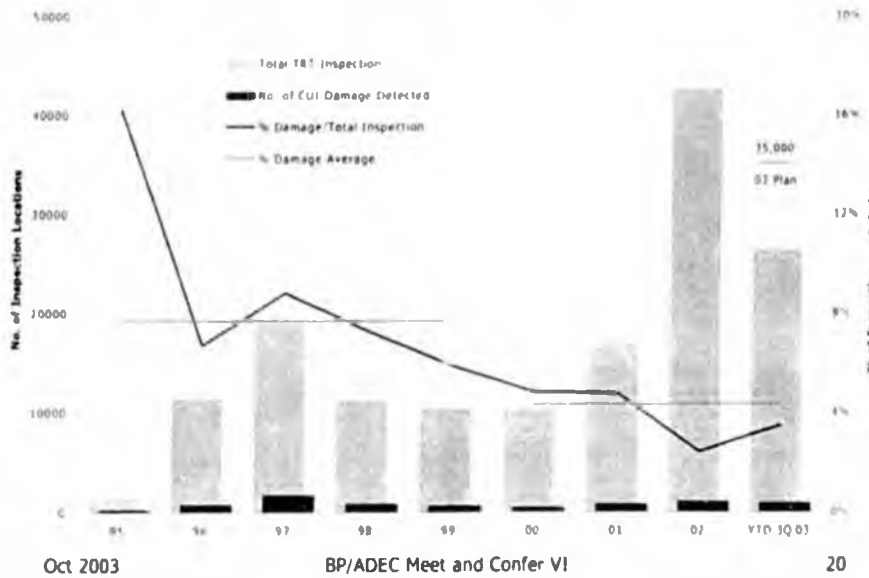

## Cased Pipe Inspection I

### ► Completed Initial Baseline Inspection

► Awaiting 2003 NDE provider(s) report

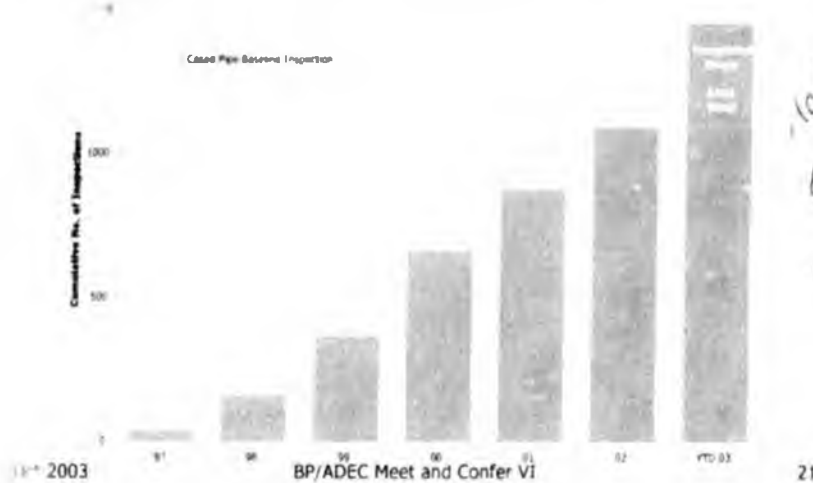

*reflects actual equipment installed since too 2 #s still installing this type of pipe*

## Cased Piping Inspection II

### ► Inspection Activity

► Baseline plus repeat inspection

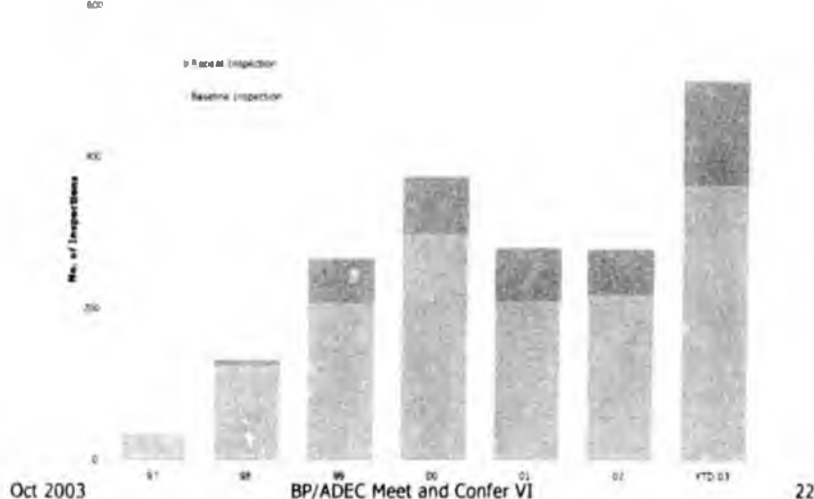

## Cased Piping Inspection III



### ► Inspection Activity

►► NDE Method

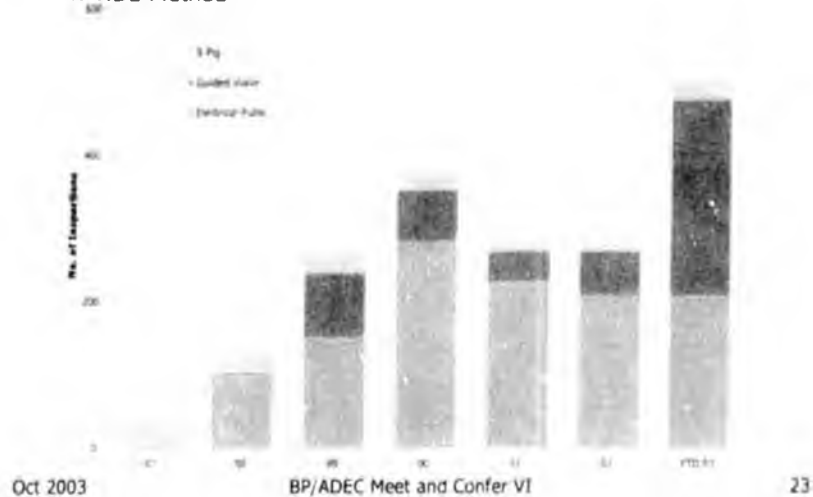

Oct 2003

BP/ADEC Meet and Confer VI

23

## Smart Pig Inspection



### ► Completed 3Q'03

Equipment ID	Diameter	Material Thickness	From	To	Service	Length (miles)
PTMCLS01/02	24"	0.375"	Drill Site L1	LPC	3 Phase Production	5
S-36	24"	0.375"	S Pad	GC2	3 Phase Production	6
Y-36	24"	0.375"	Y Pad	GC1	3 Phase Production	6

### ► Tentative 4Q'03

Equipment ID	Diameter	Material Thickness	From	To	Service	Length (miles)
STP-36	36"	0.375"	PM2	GC1	3 Phase Production	~11

Oct 2003

BP/ADEC Meet and Confer VI

24

## Smart Pig Inspection II

### ▶ Interim Report

- Pt. Mac Common Line*
- ▶▶ 2 locations on PTMCLS01/02
  - ▶▶ Field verification of interim report damage assessment
    - FFS assessed by PR-3-805 Modified Criterion as cited in CFR 195
    - 1<sup>st</sup> location *31G annular heater*
      - CUI damage - failed B31.4 80% criteria
      - Line immediately shut-in and sectional repair completed
    - 2<sup>nd</sup> location
      - Coincident internal and external damage
      - Fit-for-service with MOP greater than design

### ▶ Final reports

- ▶▶ Not yet received

### ▶ Smart Pig FollowUp

- ▶▶ Validation and verification with NDE
- ▶▶ Results reported under routine NDE

Oct 2003

BP/ADEC Meet and Confer VI

25

## YTD 2003 Spill Summary

### ▶ Spill Location Summary

	Affected Surface	
	Internal	External
Well Line	-	-
Flow Line	-	1

### ▶ Spill Mechanism Summary

	Mechanism		
	CO <sub>2</sub>	Erosion	CUI
Well Line	-	-	-
Flow Line	-	-	1

### ▶ Spill Fluid Summary

	Service		
	Prod	SW	PW
Well Line	-	-	-
Flow Line	1	-	-

Oct 2003

BP/ADEC Meet and Confer VI

26

## Y-36 Large Diameter Flowline



### ▶ Incident Summary

- ▶▶ May 27<sup>th</sup> 2003 leak detected
- ▶▶ Line shut-in and insulation removed
- ▶▶ Leak occurred at caribou crossing

### ▶ Inspection

- ▶▶ Gravel and casing cut back approx. 8'
- ▶▶ Corrosion network present 360°
  - Leak at 06:00 o'clock position
  - Network stopped 12" inside of insulation

### ▶ Cause

- ▶▶ Failure caused by external corrosion
  - Water ingress via UT insulation window

### ▶ Corrective Action Plan

- ▶▶ Sleeve installed at location
- ▶▶ Additional visual/NDE inspection
  - Similar configurations across GPB



Line leak and sleeve installation



Oct 2003

BP/ADEC Meet and Confer VI

27

*Sleeve was welded out after 4 am part repaired*

## Y-36 Corrective Action Plan Scope



### ▶ Visual Inspection of All Below Grade Piping

- ▶▶ Observations recorded at each crossing
  - Insulation missing/damaged
    - Evidence of corrosion/visible by-product
  - Tide/water marks
  - Casing blockage/debris
  - Casing overburden
  - Non-bearing/unsupported pipe

- ▶▶ Review inspection history
- ▶▶ Audit cased pipe inventory records

### ▶ Additional 2003 Cased Pipe Inspection Over Plan

- ▶▶ All segments with missing insulation at or near crossing
- ▶▶ All segments with water/tide marks not examined in prior 3 years
- ▶▶ Any segments resulting from audit not inspected

*1700' - all on pad, welded*

Oct 2003

BP/ADEC Meet and Confer VI

28

## Y-36 Corrective Action Plan YTD Progress I



- ▶ **Visual Survey and Audit Completed**
  - ▶ Observed 31 segments with external corrosion at missing insulation
  - ▶ All locations with missing insulation identified
- ▶ **NDE Followup**
  - ▶ 31 locations examined and prioritized by TRT
    - 3 locations for immediate excavation/mitigation
    - 28 locations added to expanded 2003 NDE program
  - ▶ 3 Segments - Excavation/Mitigation
    - Sleeve repair upstream/downstream - 1 crossing (24" X-74)
    - Replaced complete pipe segment - 1 crossing (14" NGI/CCP)
    - Location fit-for-service - 1 crossing (24" F-74)
- ▶ **Additional 2003 Inspection Program**
  - ▶ Increased cased pipe NDE scope by ~200 segments
  - ▶ Total 2003 program scope ~500 locations

Oct 2003

BP/ADEC Meet and Confer VI

29

## Y-36 Corrective Action Plan YTD Progress II



- ▶ **2003 Cased Pipe Scope Breakdown**

	No.	%	Notes
▶ Electrical Pulse	207	41%	
▶ Guided Wave	268	54%	28 with corrosion All with missing insulation Electrical pulse validation
▶ Smart Pigging	25	5%	Includes Y-36 post spill
- ▶ **Thermal Insulation**
  - ▶ Replacement of missing insulation at cased crossing
    - On-going ~75% complete
- ▶ **Outstanding Actions**
  - ▶ Awaiting final analysis of cased pipe inspection results
  - ▶ Develop recommendation/prioritization of reported damage
  - ▶ Develop long term cased pipe program
    - On-going activity versus baseline
    - Monitoring versus discovery

Oct 2003

BP/ADEC Meet and Confer VI

30



## Summary

### ▶ **Internal Corrosion**

#### ▶ 3 Phase Systems

- Lines showing sustained performance
- Proactive process of corrective action

#### ▶ Water Injection Systems

- Well line PW and SW systems improving
  - Caution - SW system limited/preliminary data
- Flow line water injection
  - Coupon program showing improvement
  - Discrepancy between coupon and inspection trends

### ▶ **External Corrosion**

- ▶ On track to deliver 35,000 locations in 2003
- ▶ Cased pipe baseline inspection on-track for completion by end 2003

### ▶ **Y-36 Spill and Followup Actions**

- ▶ Significant increase in cased pipe effort

Oct 2003

BP/ADEC Meet and Confer VI

31

CPA

# ConocoPhillips

## Commitment To Corrosion Monitoring Overview

presented to the  
Alaska Department of Environmental Conservation  
*6<sup>th</sup> Meet. & Confer*

October 30, 2003

Corrosion Spills - Cross Country Lines

- ✓ Over 38,000 ft of over 198 lines inspected (RTR and RT)
- ✓ On schedule to complete baseline inspection on elbows due for inspection under our Turbulent Flow Area Inspection Program
- ✓ 1 Leak (injector), 3 Saves (1 injector, 2 producers)
- ✓ Linear Array appears to work on 16" and smaller water packed lines.

2003

**Internal Corrosion Spills - Cross Country Lines**  
 1994 Spill 24" 1Y/R Crude Oil  
 2003 Spill 8" 3B Sea Water

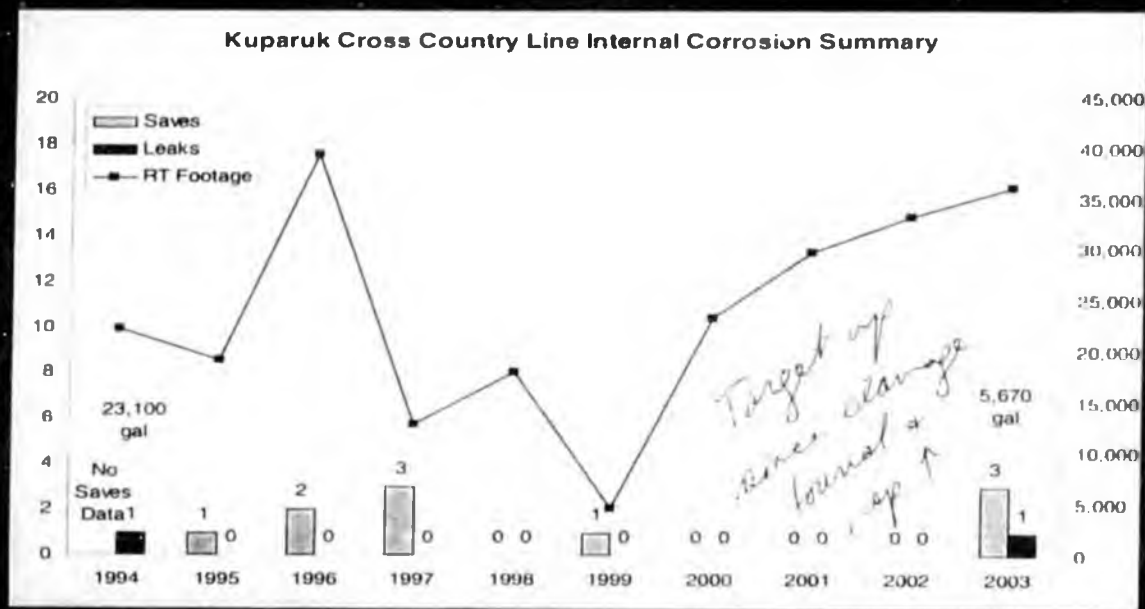

2003

- ✓ On schedule to complete baseline inspection of all well lines due for inspection
- ✓ Over 13,000 ft of over 469 lines inspected (RTR and RT) so far.
- ✓ 21 lines required repair (17 injectors, 4 producers)
- ✓ 0 Leaks, 21 Saves

**Internal Corrosion Spills  
- Well Lines**

1998 Spills	1L-1 6" WI
	1L-3 6" WI
	1A-9 6" WI
2000 Spill	1G-8 6" PC
2002 Spills	2A-18 6" PC
	2T-13 6" PC

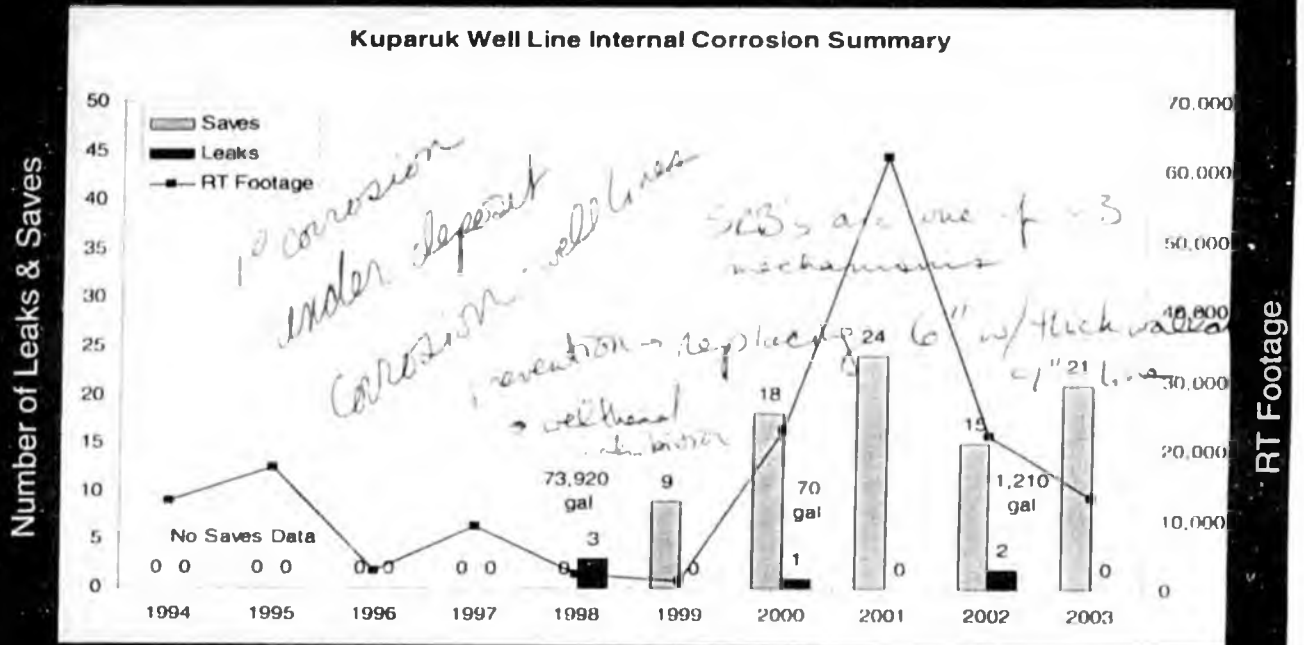

2003 Goals - 50% Increase in RTR

<b>Cross-Country Lines</b>	
<i>Goal</i>	<i>Status</i>
Inspect ~ 15,000 feet by RTR.	Inspected 38,000 feet
Complete elevation change elbow inspections	On schedule to complete
Prioritize and finalize plan to inspect WI lines >10" OD.	List compiled, Finalizing '04 plan.
<b>Well Lines</b>	
Complete baseline inspection of all 6" OD, 0.312 and 0.375" six years old or older or since previous inspection.	On schedule to complete

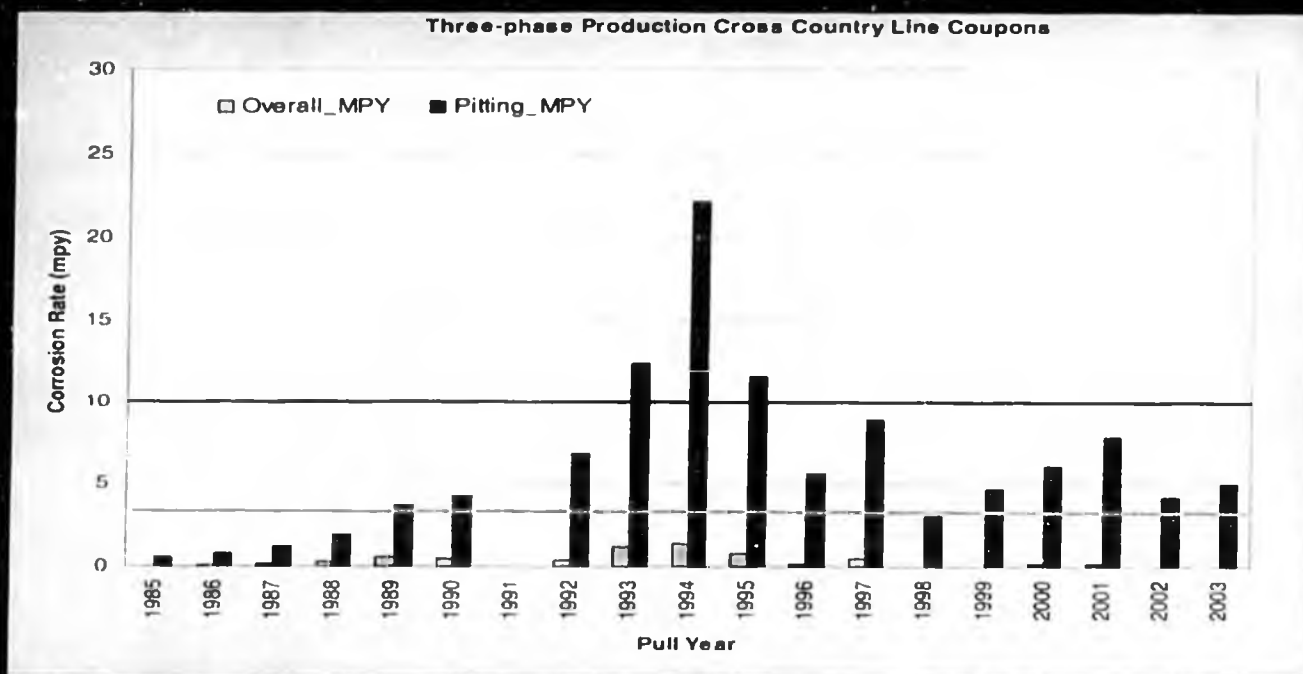

2003

- ✓ Coupon average rates remain below thresholds
- ✓ 95% of 3-Phase Production CC lines have ER probe rates < 2 mpy
- ✓ 3% of repeat inspection locations showed increases
- ✓ All inhibited 3-Phase Production CC lines with probe, coupon, or inspection corrosion rates above thresholds had corrective action taken

2003

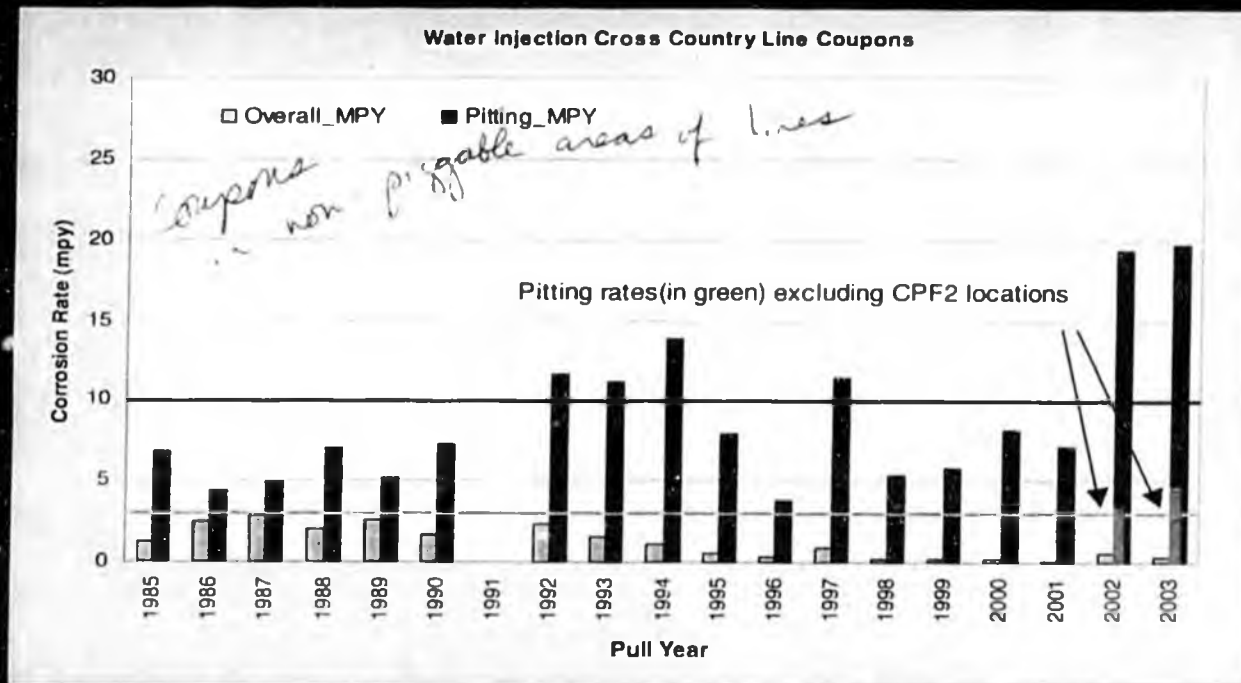

- ✓ Average corrosion rates affected by lines at CPF2.
- ✓ Since 2001, all 16 CPF2 CC WI lines under 12" dia. inspected with RTR. Two lines showed damage greater than 30% wall loss using UT.
- ✓ Biocide study completed and formal recommendations implemented at CPF2 and in progress at other two CPF's.

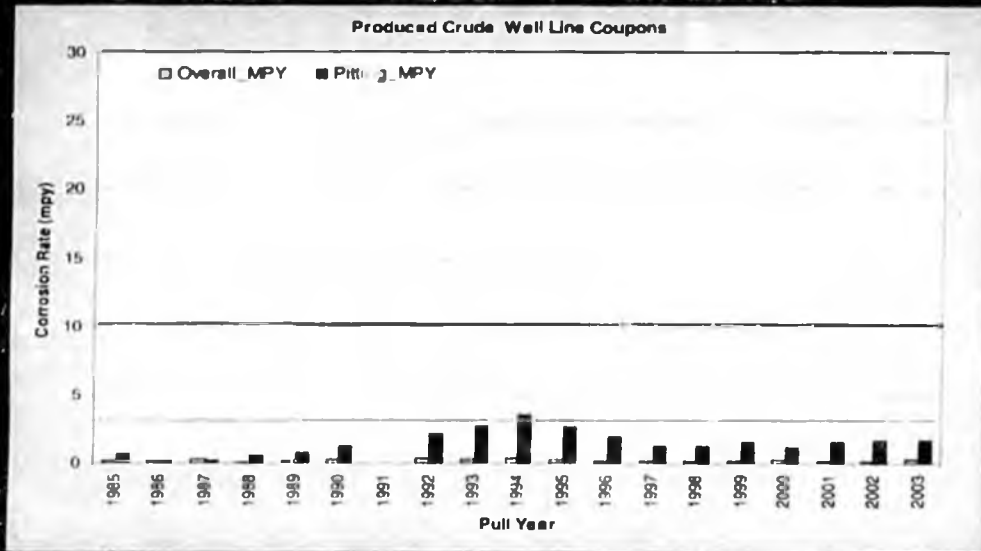

- ✓ Coupon average corrosion rates remain below threshold levels
- ✓ Well head Cl injection being installed at DS's 2T, 1H, 1A, 1Y

Water Injection Well Lines

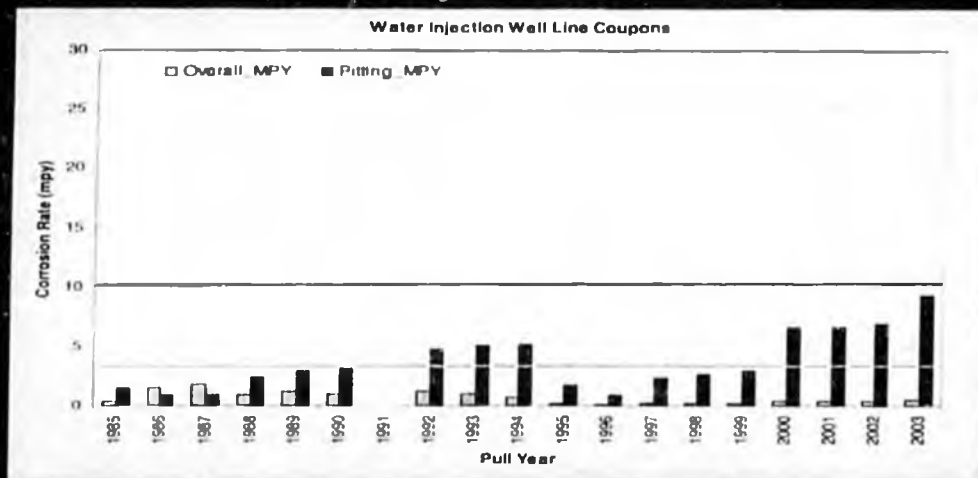

- ✓ Coupon average corrosion rates remain below targets
- ✓ Inspection data indicates higher corrosion rates in some lines
- ✓ KDR locations are identified

<b>Monitoring &amp; Mitigation</b>	
<b>Goal</b>	<b>Status</b>
Continue testing for more effective corrosion inhibitors	<ul style="list-style-type: none"> <li>• Field test of Champion 2002-049A completed at DS1R. Next test planned for 2UVW system in November</li> <li>• Field test of Champion 2002-050B pending at DS1R. Evaluation of another field test candidate in progress</li> </ul>
Complete Implementation of wellhead corrosion inhibitor injection at 4 more Drill Sites	<ul style="list-style-type: none"> <li>• DS's 1A, 1H, 1Y, 2T engineering and construction in progress</li> <li>• Added chemical tech position to perform system maintenance</li> </ul>
Complete initial investigation of CPF2 PW System anomalies	<ul style="list-style-type: none"> <li>• Biocide study completed</li> <li>• Recommendations are being implemented</li> </ul>
SBG (Surfactant) Produced Water System Pilot Test	<ul style="list-style-type: none"> <li>• Hardware installed, remaining work in progress</li> </ul>

2003

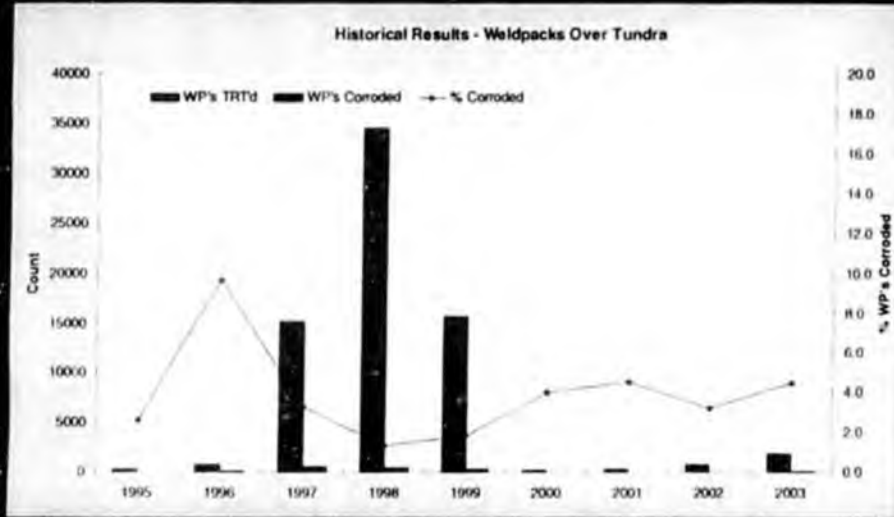

- ✓ 1864 weld packs TRT inspected. 83 had corrosion or ~5%. No repairs.
- ✓ Walkdown verification underway
- ✓ Approx. 1,000 weld packs identified so far that need baseline inspection.

CC Lines On Pad

- ✓ Overall program completion - 96%
- ✓ 352 weld packs TRT'd YTD (long weld packs, high)
- ✓ The % corroded weld packs found increased to 5.1%. No Repairs

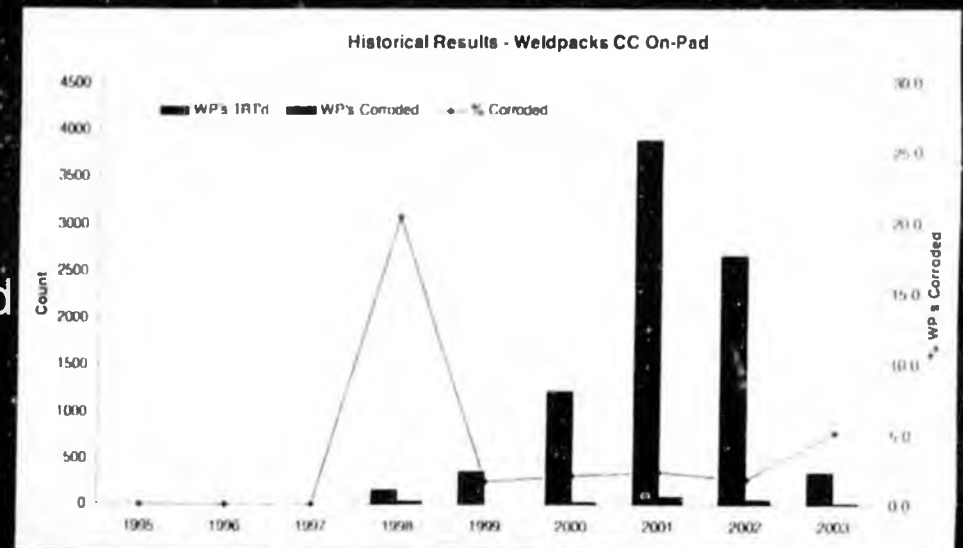

2003

- ✓ Overall program completion - 77%
- ✓ Annual goals for 2003, 2004, and 2005 revised to 2,500.
- ✓ 2358 weld packs TRT'd YTD
- ✓ % Corroded decreased to 1.5%
- ✓ Two locations repaired

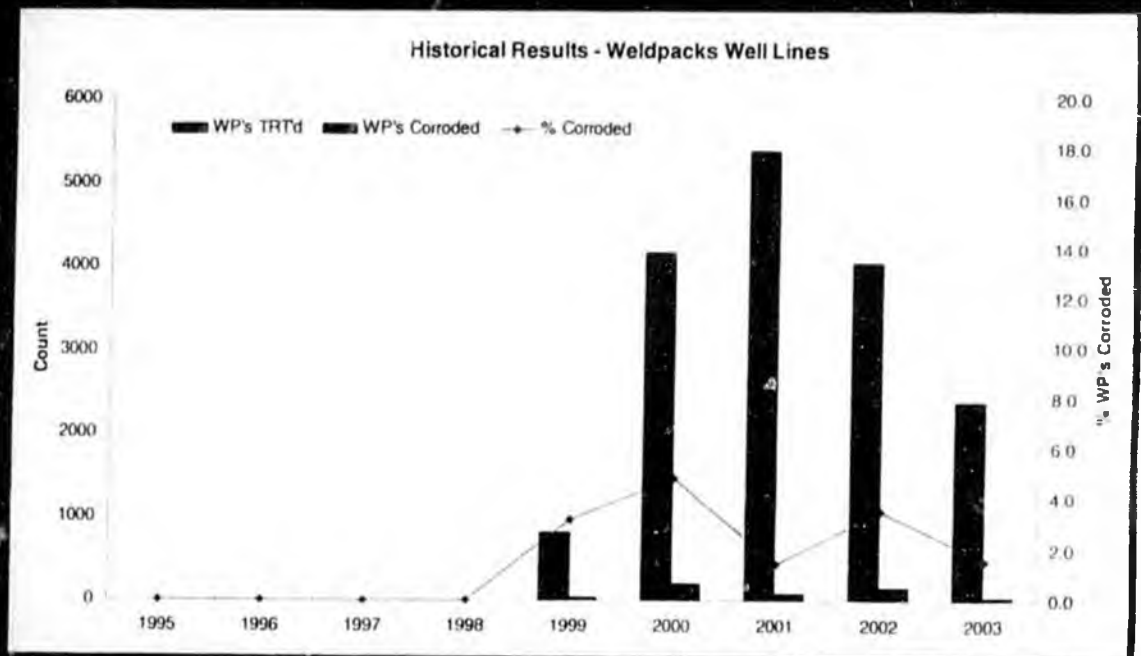

## Buffer Spike Summary

- pH data was obtained on all test locations.
- Field review of this data indicates that the pH increased substantially in the wet insulation.
- The 2003 progress report has not yet been completed.
- TRT of the test locations planned for 2004

<b>Cross-Country Lines Over Tundra</b>	
<b>Goal</b>	<b>Status</b>
Complete walk down verification of 172 high priority lines.	Have completed 140 lines YTD, 81%.
TRT approx. 100 'Tarn Design' WPs	<b>Complete:</b> 100 WPs were inspected using C-arm. No water was found.
Continue monitoring of 'Denso Tape' refurb. technique	Continued spot checks of locations. No failures found
Develop long term recur.schedule/program	In progress. Gathering inspection data.
<b>Cross-Country On-Pad</b>	
Inspect 50% of remaining WPs (343) with goal of 2004 YE completion of baseline inspections	<b>Complete:</b> 352 WPs TRT'd YTD
<b>Well Line Weld Packs</b>	
Inspect 17% of weld packs, 2005 completion	Goal revised to 2500. 2358 WPs TRT'd YTD; on track for 2005 completion
<b>Misc.</b>	
Evaluate last summer's CUI Buffer Spike pilot program	Pending final report from B'ville

2003

- ✓ Re-inspected 82 priority 1 locations with PTI/TWI
- ✓ Inspected all priority 2 locations
- ✓ 6 cased pipes excavated so far (goal was 5 to 9)
  - One had severe internal damage - pipe was replaced
  - One had moderate internal damage - scheduled for replacement in 2004
  - Four had only minor or no significant corrosion
  - Tally so far: 6 Refurbishments, 2 Saves, No Leaks
- ✓ Completed Annual Visual Casing Inspection - cleared all obstructions

Note: The only uninspected priority 1 lines are those that are newer than 10 years old

All Lines in GKA/AOA Inventory	Inspected Thru 10/31/03	Un-inspected Lines	Total	Previously Uninspected Lines Inspected in 2003
Priority 1 Oil	327	40	367	0
Priority 1 Non-Oil	236	21	257	1
Priority 2 Oil	14	1	15	0
Priority 2 Non-Oil	84	0	84	0
Priority 3 Oil	3	26	29	0
Priority 3 lines Non-Oil	1	22	23	0
<b>2002 Total Inventory</b>	<b>665</b>	<b>110</b>	<b>775</b>	<b>1</b>

<i>Goal</i>	<i>Status</i>
Reinspect ~ 60 priority 1 pipes using PTI/TWI.	Inspected 82.
Complete baseline inspection of all ~ 115 priority 2 pipes using PTI/TWI selectively where warranted	Completed visual and casing gas analysis on all pipes, no PTI/TWI inspections warranted.
Prioritize and excavate 5-9 pipes.	Completed 6 excavations so far.
Continue cooperative effort with equipment vendors, COP R&D and BP to improve current technology and explore new technologies.	B&E tested in '03. Found no reason to switch to this technology at this time.

2003

**External Corrosion**

✓ No incidents to report

**Internal Corrosion**

✓ No new incidents to report since April meeting

- 13 pipeline supports failed – Attributed to fatigue
- No breach or reduction of pipeline integrity
- Pipeline support reinstated successfully w/o incident
- Best practices captured & implemented
- Field-wide inspections for similar installations complete
- All support installations surveyed confirmed fit-for-service

ConocoPhillips

**THE END**

**Equipment Classification:**

**Well Line** – Pipe from the wellhead to the Drill Site manifold. For production wells, a well line handles the flow from a single well prior to commingling with fluids from other wells and transportation to the Central Processing Facility. For water injection wells, a well line handles the water flow going from a common manifold to a single wellhead.

**Cross-Country Line** – Pipe from the Drill Site manifold to the Central Processing Facility (CPF).

**Below-Grade Location** – That portion of a single pipeline, which crosses underneath a road or other earthen feature at a single location. The linear extent of the location consists of the length of pipeline between casing ends.

**Service Definitions:**

**Three-phase Production** – Basic reservoir fluids (oil, water, and gas) produced from down hole through to the CPF. Typically sees changes in temperature and pressure only from reservoir changes and are essentially un-separated.

**Seawater (SW)** – Water from the Beaufort Sea that has been treated at the Seawater Treatment Plant (STP). Note that seawater treatment at the Kuparuk STP consists of filtration, oxygen stripping using produced gas, and biociding.

**Produced Water (PW)** – The water separated at the CPF from three-phase production.

**Mixed Water (MW)** – Produced water and seawater that have been commingled.

**Gas** – Generic term for the different gas systems that transport dry (no liquids) gas between facilities. Includes fuel gas, artificial lift gas, and miscible Injectant.

**Produced Oil** – The liquid hydrocarbon separated at the CPF from three-phase production.

**Inspection Terminology:**

**CRM** – Corrosion rate monitoring.

**UT** – Ultrasonic testing

**RT** – Radiographic testing

**RTR** – Real time radiographic testing

**TRT** – Tangential radiographic testing

**PTI** – Profile Technologies Inc. (Electro magnetic inspection)

**TWI** – The Welding Institute (Long range UT)

**KDR** – Known damage recur inspection