

SB

111

FISCAL NOTE

STATE OF ALASKA
2001 LEGISLATIVE SESSION

Fiscal Note Number: _____
 Bill Version: SB 111
 () Publish Date: _____

Revision Date/Time (Note if correction): _____ Dept. Affect: Revenue
 Title: Bonds to Fund Ports and Harbors BRU: Alaska Housing Finance Corp
harbors Component: Operations
 Sponsor: Senator Taylor
 Requester: Senate Transportation Component Number: 110

Expenditures/Revenues (Thousands of Dollars)

Note: Amounts do not include inflation unless otherwise noted below.

OPERATING EXPENDITURES	FY 2002	FY 2003	FY 2004	FY 2005	FY 2006	FY 2007
Personal Services						
Travel						
Contractual						
Supplies						
Equipment						
Land & Structures						
Grants & Claims						
Miscellaneous						
TOTAL OPERATING	0.0	0.0	0.0	0.0	0.0	0.0

CAPITAL EXPENDITURES						
-----------------------------	--	--	--	--	--	--

CHANGE IN REVENUES ()						
-------------------------------	--	--	--	--	--	--

FUND SOURCE (Thousands of Dollars)

1002 Federal Receipts						
1003 GF Match						
1004 GF						
1005 GF/Program Receipts						
1037 GF/Mental Health						
Other (Specify Type)						
TOTAL	0.0	0.0	0.0	0.0	0.0	0.0

Estimate of any current year (FY2001) cost: 0.0

Check this box (X) if funding for this bill is included in the Governor's FY 2002 budget proposal:

POSITIONS

Full-time						
Part-time						
Temporary						

ANALYSIS: (Attach a separate page if necessary)
 SB111 authorizes the Alaska Housing Finance Corporation to issue general obligation bonds of the corporation to pay for \$34,627,500 in improvements for ports and harbors statewide. The bill is written as a retroactive amendment to Ch. 130, SLA 2000, which authorized financing for ports, harbors, the university, senior housing and student housing.

Bonds for the projects authorized in Ch. 130 have already been sold, with AHFC's \$50 million dividend pledged as a debt service payment for the bonds through fiscal year 2007. Additional bonding capacity of AHFC for state capital projects is currently zero. Therefore, this fiscal note is drafted as a zero based on the belief that additional AHFC state capital project bonding capacity is unavailable.

Prepared by: John Bitney, Legislative Liaison Phone 330-8445
 Division: Alaska Housing Finance Corporation Date/Time 3/19/01 12:00 AM
 Approved by: Larry Persily, Deputy Commissioner Date 03/19/2001
 Agency: Department of Revenue

For distribution information, call the Governor's Legislative Office

22-LS0621F

Cook

3/23/01

CS FOR SENATE BILL NO. 111(TRA)
IN THE LEGISLATURE OF THE STATE OF ALASKA
TWENTY-SECOND LEGISLATURE - FIRST SESSION

BY THE SENATE TRANSPORTATION COMMITTEE

Offered:
Referred:

Sponsor(s): SENATOR TAYLOR

A BILL
FOR AN ACT ENTITLED

1 "An Act relating to the issuance of certificates of participation to finance deferred
2 maintenance and construction projects for certain public harbor facilities; giving notice
3 of and approving the entry into, and the issuance of certificates of participation in, lease-
4 financing agreements for those public harbor facility projects; repealing a provision
5 relating to the financing of construction and renovation of facilities for certain ports and
6 harbors; and providing for an effective date."

7 **BE IT ENACTED BY THE LEGISLATURE OF THE STATE OF ALASKA:**

8 * **Section 1.** The uncodified law of the State of Alaska is amended by adding a new section
9 to read:

10 FINDINGS; INTENT. (a) Except for the harbors and docks in Nome and Adak, the
11 facilities described in sec. 2 of this Act are currently owned by the state and are in need of
12 substantial investment in capital maintenance and upgrades. The City of Nome is in need of
13 additional money for a capital project at the Nome harbor and dock. The Adak harbor and

1 dock facilities are currently in federal ownership but will pass to local Alaska interests in the
2 fall of 2001.

3 (b) The legislature intends to provide for the required investment, and intends transfer
4 of ultimate ownership of and responsibility for the state-owned harbor facilities to local
5 municipalities.

6 (c) The legislature intends to provide public investment in the Adak harbor and dock
7 facilities under this Act if the ownership of the harbor and dock facilities is ultimately vested
8 in the City of Adak.

9 * Sec. 2. The uncodified law of the State of Alaska is amended by adding a new section to
10 read:

11 HARBOR FACILITIES LEASES AUTHORIZED. (a) The Department of
12 Transportation and Public Facilities is authorized and directed to develop a plan for
13 improvement and financing of the state-owned harbor facilities listed in (b) of this section and
14 for the transfer of ownership and responsibility for the improved facilities, subject to the
15 limitations set out in this Act, to the municipalities listed in (b) of this section. The
16 Department of Transportation and Public Facilities is authorized to lease the harbor facilities
17 from the municipalities listed in (b) of this section, including the City of Nome, under the
18 authority of AS 35.10.110.

19 (b) The Department of Transportation and Public Facilities shall allocate the net
20 proceeds derived from the lease-financing agreements authorized in sec. 6 of this Act for
21 capital maintenance and upgrade projects, including the City of Nome's project and the Adak
22 project, to the following harbor facility projects, in the amount allocated for each facility:

23 FACILITY/PROJECT	ALLOCATION
24 (1) Whittier - Whittier Small Boat Harbor	\$2,449,000
25 (2) Valdez - Valdez Small Boat Harbor	3,212,000
26 (3) Seldovia - Seldovia Small Boat Harbor	2,628,000
27 (4) Petersburg - North Harbor, Middle Harbor, South Harbor	3,729,000
28 (5) Juneau - Auke Bay Harbor, Aurora Basin, Harris Harbor, 29 Douglas Harbor and Dock, North Douglas Launch 30 Ramp, Taku Harbor	7,119,000
31 (6) Ketchikan - Thomas Basin Harbor, Ryus Float, Bar Harbor	

1	South, Bar Harbor North, Hole-in-the-Wall Harbor,	
2	Knudson Cove Harbor	7,876,000
3	(7) Sitka - Thomsen Harbor, Crescent Harbor,	
4	Sealing Cove Harbor	4,469,000
5	(8) Cordova - Cordova Harbor	4,876,000
6	(9) Klawock - Klawock Harbor and Seaplane Float	896,000
7	(10) Yakutat - Yakutat Harbor	526,000
8	(11) Wrangell - Standard Harbor, Reliance Float, Inner Harbor	
9	Fish and Game Dock, Shoemaker Harbor	3,492,000
10	(12) Nome - Nome Harbor and Dock	1,000,000
11	(13) Adak - Adak Boat Harbor	500,000

12 * Sec. 3. The uncodified law of the State of Alaska is amended by adding a new section to
13 read:

14 DELEGATION OF AUTHORITY FOR LEASE-FINANCING AGREEMENTS. The
15 Department of Transportation and Public Facilities is delegated the Department of
16 Administration's authority under AS 36.30.085 to enter into lease-financing agreements for
17 the harbor facility projects described in sec. 2 of this Act.

18 * Sec. 4. The uncodified law of the State of Alaska is amended by adding a new section to
19 read:

20 PROVISIONS REGARDING ESTABLISHMENT OF THE CITY OF ADAK AND
21 THE ADAK HARBOR AND DOCK FACILITIES. (a) Adak is a naval air station that has
22 closed. The Adak Reuse Corporation has developed, with financial assistance from the
23 federal government, a reuse plan for the redevelopment of the former naval air station and its
24 facilities to support fishing operations in the North Pacific Ocean and the Bering Sea. In the
25 fall of 2001, the Adak Reuse Corporation will receive title to the former naval air station from
26 the federal government. The Adak community is presently not incorporated as a municipality
27 under state law. The Local Boundary Commission has approved the community's application
28 to establish a second class city at Adak. The division of elections has scheduled for April 3,
29 2001, a local election in Adak to approve its incorporation as a second class city.

30 (b) The commissioner of transportation and public facilities is authorized to enter into
31 a lease with the Adak Reuse Corporation for the Adak harbor and dock facilities under the

1 terms the commissioner determines appropriate, so long as title to the harbor and dock
2 facilities is vested in the City of Adak at the end of the lease term.

3 * Sec. 5. The uncodified law of the State of Alaska is amended by adding a new section to
4 read:

5 LEASE-FINANCING PAYMENTS. (a) The lease payments owed under lease-
6 financing agreements executed under sec. 3 of this Act are subject to annual appropriation by
7 the legislature.

8 (b) The legislature intends that the marine motor fuel tax collected under
9 AS 43.40.010 will provide enough revenue to the general fund to make all lease payments;
10 however, if that revenue source is insufficient, the payments may be made from any other
11 valid revenue source, subject to appropriation.

12 * Sec. 6. The uncodified law of the State of Alaska is amended by adding a new section to
13 read:

14 NOTICE OF THE ENTRY INTO AND FINANCING OF LEASE-FINANCING
15 AGREEMENTS. (a) Subject to annual appropriation, the Department of Transportation and
16 Public Facilities is authorized to enter into lease-financing agreements for the harbor facility
17 projects described in sec. 2 of this Act.

18 (b) The state bond committee is authorized to provide for the issuance of certificates
19 of participation in one or more series in the aggregate principal amount of \$42,772,000 for the
20 cost of the projects described in sec. 2 of this Act. The estimated total cost of construction,
21 acquisition, and equipping the projects is \$42,772,000. The estimated annual amount of rental
22 obligations under the lease-financing agreements is \$4,525,000. The estimated total lease
23 payments for the full term of the lease-financing agreements is \$66,335,500. In this
24 subsection, "costs of construction" includes credit enhancement and underwriting expenses,
25 rating agency fees, bond counsel fees, financial advisor fees, printing fees, trustee fees,
26 capitalized interest, and interest earnings used for lease payments.

27 (c) Under terms approved by the Department of Transportation and Public Facilities,
28 the leasehold interests of the state in projects described in sec. 2 of this Act that are financed
29 under this section may terminate following the payment and retirement of the certificates of
30 participation or at another later date as considered reasonable by the Department of
31 Transportation and Public Facilities. The plan prepared by the Department of Transportation

1 and Public Facilities under sec. 2 of this Act may provide for the transfer of title to some or all
2 of the state-owned harbor facilities to the municipalities identified in sec. 2 of this Act, with a
3 leaseback to the department, as long as the title to the state-owned facilities transfers to
4 municipal ownership no later than the final payment and retirement of all certificates of
5 participation issued to finance the respective projects.

6 (d) The state bond committee may contract for credit enhancement, underwriting,
7 credit ratings, bond counsel, financial advisor, printing, and trustee services that the
8 committee considers necessary in financing the projects described in sec. 2 of this Act.

9 * **Sec. 7.** The uncodified law of the State of Alaska is amended by adding a new section to
10 read:

11 NOTICE AND APPROVAL OF AGREEMENTS. Section 6 of this Act constitutes
12 the notice and approval of the lease-financing agreements described in sec. 2 this Act that is
13 required by AS 36.30.085.

14 * **Sec. 8.** AS 29.60.700 is repealed

15 * **Sec. 9.** This Act takes effect July 1, 2001.

Interim:
716 West 4th Ave.
Anchorage, AK 99501

Phone: 907-269-0222
Fax: 907-269-0223



Senator
John J. Cowdery

Session:
State Capitol Bldg.
Juneau, AK 99801

Phone: 907-465-3879
Fax: 907-465-2069
Toll Free: 1-888-269-3879

FAX COVER

DATE: 3/23/01 TIME: 8:40

TO: TAMARA COOK

FAX: 465-2029 PHONE: _____

FROM: AM SMITH - SENATE TRANSP.

FAX: _____ PHONE: _____

NUMBER OF PAGES: (INCLUDING COVER) _____

NOTES: Attached are the amendments
to SB 111 -

as we discussed on the phone
I believe these amendments would
create a bill identical to SB 118 -

This message is intended only for the use of the individual or entity to which it is addressed and may contain information that is privileged, confidential and exempt from disclosure under applicable law. If the reader of this message is not the intended recipient or the employee or agent responsible for delivering the message to the intended recipient, you are hereby notified that any dissemination, distribution, or copying of this communication is strictly prohibited. If you have received this communication in error, please notify us immediately by telephone and return the original message to us at the address listed above. Thank you.

**Changes required to comply with amendments made to SB 111
by Transportation Committee on March 22, 2001:**

Number 1

**Amend to allow public investment in Adak harbor provided
ownership is ultimately vested in the City of Adak.**

Number 2

**Amend to add Adak - \$500,000; Yakutat - \$526,000 and
Juneau - \$7,119,000.**

Number 3

**Amend to change mechanism of funding to Certificates of
Participation.**

22-LS0621\C
Cook
3/20/01

CS FOR SENATE BILL NO. 111()
IN THE LEGISLATURE OF THE STATE OF ALASKA
TWENTY-SECOND LEGISLATURE - FIRST SESSION

BY

Offered:
Referred:

Sponsor(s): SENATOR TAYLOR

A BILL

FOR AN ACT ENTITLED

1 **"An Act providing for and relating to the issuance of general obligation bonds for the**
2 **purpose of paying the cost of construction and renovation of port and harbor facilities;**
3 **and providing for an effective date."**

4 **BE IT ENACTED BY THE LEGISLATURE OF THE STATE OF ALASKA:**

5 *** Section 1.** The uncodified law of the State of Alaska is amended by adding a new section
6 to read:

7 **GENERAL OBLIGATION BONDS.** For the purpose of paying the cost of
8 construction and renovation of port and harbor facilities, general obligation bonds of the state
9 in the principal amount of not more than \$34,627,500, if authorized by the qualified voters of
10 the state, shall be issued and sold. The full faith, credit, and resources of the state are pledged
11 to the payment of the principal of and interest and redemption premium, if any, on the bonds.
12 The bonds shall be issued under the provisions of AS 37.15 as those provisions read at the
13 time of issuance.

14 *** Sec. 2.** The uncodified law of the State of Alaska is amended by adding a new section to

1 read:

2 PORTS AND HARBORS FUND. If the issuance of the bonds is authorized by the
3 qualified voters of the state, a special fund of the state to be known as the "Ports and Harbors
4 Fund" shall be established, to which shall be credited the proceeds of the sale of the bonds
5 described in sec. 1 of this Act except for the accrued interest and premiums.

6 * Sec. 3. The uncodified law of the State of Alaska is amended by adding a new section to
7 read:

8 DEPARTMENT OF TRANSPORTATION AND PUBLIC FACILITIES. The
9 amount of \$34,627,500 is appropriated from the Ports and Harbors Fund to the Department of
10 Transportation and Public Facilities to be allocated among the following projects for
11 construction and renovation of port and harbor facilities in the amounts listed subject to
12 reallocation between projects in accordance with AS 37.07.080(e):

13	PROJECT	AMOUNT
14	Ketchikan	\$ 7,876,000
15	Petersburg	3,729,000
16	Sitka	4,469,000
17	Wrangell	3,492,000
18	Klawock	896,000
19	Seldovia	2,628,000
20	Whittier	2,449,000
21	Valdez	3,212,500
22	Cordova	4,876,000
23	Nome	1,000,000

24 * Sec. 4. The uncodified law of the State of Alaska is amended by adding a new section to
25 read:

26 STATE BOND COMMITTEE. If the issuance of the bonds is authorized by the
27 qualified voters of the state, the amount of \$121,196 or as much of that amount as is found
28 necessary is appropriated from the general fund of the state to the state bond committee to
29 carry out the provisions of this Act and to pay expenses incident to the sale and issuance of
30 the bonds authorized in this Act. The amounts expended from the appropriation authorized by
31 this section shall be reimbursed to the general fund from the proceeds of the sale of the bonds

1 authorized by this Act.

2 * Sec. 5. The uncodified law of the State of Alaska is amended by adding a new section to
3 read:

4 ADVANCE PLANNING. The amount withdrawn from the public facility planning
5 fund (AS 35.10.135) for the purpose of advance planning for the capital improvements
6 financed under this Act shall be reimbursed to the fund from the proceeds of the sale of bonds
7 authorized by this Act.

8 * Sec. 6. The uncodified law of the State of Alaska is amended by adding a new section to
9 read:

10 LAPSE; REDEMPTION; REIMBURSEMENT. The unexpended and unobligated
11 balance of the appropriation made in sec. 3 of this Act lapses under AS 37.25.020 and is
12 appropriated to the state bond committee to redeem bonds sold under this Act. The amounts
13 expended from the general fund to pay the principal, interest, and redemption premium on
14 bonds issued under this Act shall be reimbursed to the general fund from the appropriation
15 made under this section to the extent that the money is not needed to redeem the bonds.

16 * Sec. 7. The uncodified law of the State of Alaska is amended by adding a new section to
17 read:

18 BALLOT QUESTION. The question whether the bonds authorized in this Act are to
19 be issued shall be submitted to the qualified voters of the state at the next general election and
20 shall read substantially as follows:

21 PROPOSITION

22 State General Obligation Ports and \$34,627,500

23 Harbors Bonds

24 Shall the State of Alaska issue its general obligation bonds in
25 the principal amount of not more than \$34,627,500 for the
26 purpose of paying the cost of ports and harbors?

27 Bonds Yes []

28 Bonds No []

29 * Sec. 8. This Act takes effect immediately under AS 01.10.070(c).



Peratrovich, Nottingham & Drage, Inc

Engineering Consultants

1506 West 36th Avenue, Anchorage, Alaska 99503, 907-561-1011, Fax 907-563-4220

March 15, 2001

PN&D: 01035

Chris Gates
Aleut Enterprise Corporation
840 K Street, Suite 202
Anchorage, Alaska 99501

Re: Adak Small Boat Harbor Upgrade Cost Estimate

Dear Chris:

Peratrovich, Nottingham & Drage, Inc. is pleased to provide a cost estimate and attached plan sheets (2) for the proposed Adak Small Boat Harbor Upgrade for the Aleut Enterprise Corporation. The information provided is a Rough Order of Magnitude preliminary cost estimate which will be refined as the design progresses and more information becomes available.

123 5574

No.	ITEM	ROM COST EST (\$)
1	Site Mobilization & Demobilization	\$50,000
2	Demolition of Existing Floats	\$50,000
3	Floats	\$150,000
4	Piles	\$150,000
5	Engineering/Development	\$30,000
6	Miscellaneous	\$20,000
	Subtotal	\$450,000
	Contingency	\$50,000
	ROM Total	\$500,000

FN&D appreciates the opportunity to assist the Aleut Enterprise Corporation in upgrading the Adak Small Boat Harbor. We recognize the tremendous opportunity which exists for future development and expansion of marine facilities and services at this location and look forward to closely working with you in this and future projects.

Please call either Alan B. Christopherson or myself if there are any questions.

Sincerely,

Peratrovich, Nottingham & Drage, Inc.

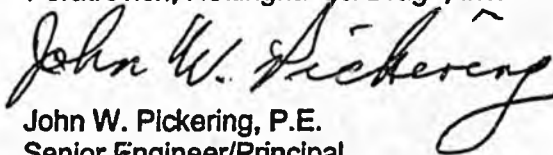

John W. Pickering, P.E.
Senior Engineer/Principal

Enc: 2 - plan sheets

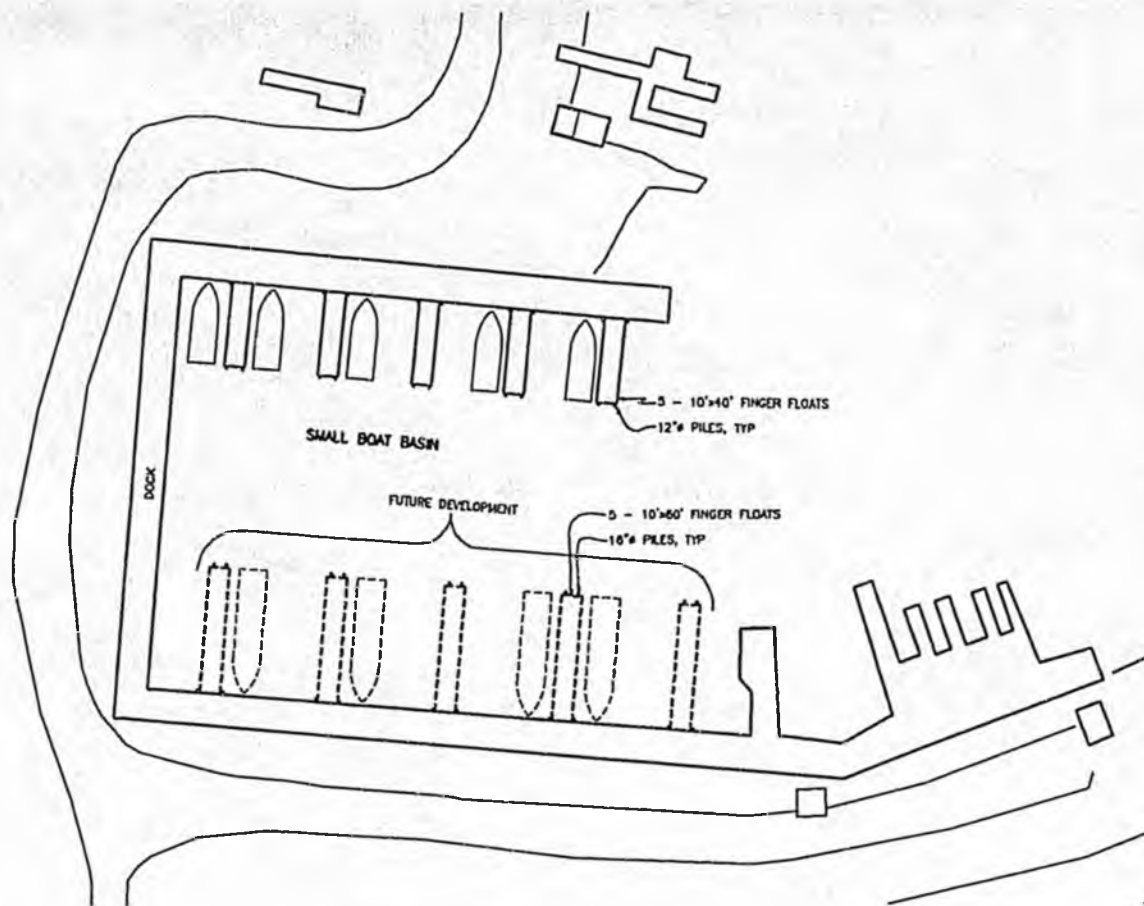

PLAN

SCALE IN FEET

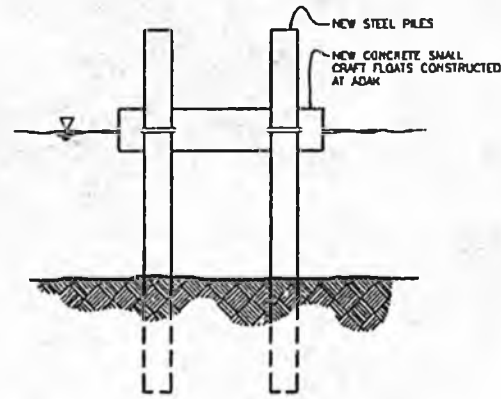

TYPICAL NEW FLOAT

**ADAK SMALL
BOAT HARBOR**

Designed: JWP
 Drawn: R.C.
 Checked: _____
 Project No: 01012
 Date: 01/22/01
 Scale: _____



Peratrovich, Nottingham & Drage, Inc.
 Engineering Consultants

1804 West 34th Avenue,
 Anchorage, Alaska 99503 (907) 561-1011 FAX (907) 943-4210

**NEW FLOAT
CONCEPT PLAN**

Sheet
2 of 2

640 File: A:\2001\010123 Adak Small Boat Harbor\Small Boat Harbor - Preliminary.dwg



**ADAK SMALL
BOAT HARBOR**

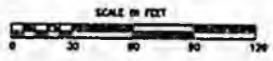

Designed J.P.
 Drawn J.C.
 Checked _____
 Project No. 21021

 **Peratrovich, Nottingham & Drage, Inc.**
 Engineering Consultants
 1508 West 38th Avenue,
 Anchorage, Alaska 99503 18071 565-1011 FAX 18071 565-4220

Date 02/22/08
 Scale 1" = 50'

EXISTING CONDITIONS

Sheet
1 - 2

500 PWS 2/10/08/10/03

Adak Reuse Corporation

PORT OF ADAK SMALL BOAT HARBOR RECONSTRUCTION AND REPAIR ISSUE PAPER

FEBRUARY 2001

Adak Island is building a new and important economic base in the Western Aleutians of Alaska.

The reuse of former Naval Air Facility Adak is being accomplished by a small corps of enthusiastic city pioneers and a non-profit, regional, advisory team called the Adak Reuse Corporation. These entities have worked with federal granting authorities to develop an Economic Reuse Plan that confirms the common sense that the successful community reuse of former Naval Facility Adak will center around fishing, port, airport, fuel farm and other opportunities.

These opportunities are derived from Adak's fundamental attributes. These include having a very unique geographic position in the Western Aleutians of Alaska (useful to serve crew change and vessel support needs of an extensive international fishing fleet), a high quality installed and working community infrastructure, over 20,000 acres of developable land, the best jet airport in the Aleutians, over 3000 linear feet of deep draught dock facilities, over 2 million square feet of commercial buildings, readily available housing for 2000 people, and a state of the art fuel terminal that can efficiently and easily store and transship over 20 million gallons of petroleum products.

In spite of the impressive listing of possible opportunities, the most important part of the reuse of Adak concerns timing. The weather and elements on Adak are expected to more quickly deteriorate new commercial and industrial facilities than almost anywhere in the country. Adak is attempting to ramp up leases and reuse of facilities as soon as possible, to put good assets into commercial use before they are lost to the elements. To act quickly Adak is focusing its limited marketing and outreach efforts towards the fishing industry.

Fishing on Adak has the potential to repopulate the community, bring in new processors and fishermen as well create a host of supply and maintenance companies to serve the fleet and the industry. Fishing in the Adak area is great. Federal regulators have given Adak a small community allocation of commercially caught cod to help start a viable fish catching and processing industry.

Unfortunately, Adak's history as a large and active military base - with regard to small boat facilities - is not well suited to transitioning into a fishing community. While the Navy had operated a recreational-oriented small boat harbor over the years, the requirements for a full fledged Aleutian fishing community are much different, and not currently available on Adak.

The existing small boat harbor is not a functional fishing vessel services harbor. It will not facilitate the establishment of a day fishery, or service other boats and parts of the industry that are needed to take advantage of the resource and facilities around Adak. The reworking, reconfiguring, repair and expansion of Adak's small boat harbor is the single most important requirement to continue the establishment of a sustainable economic foundation for the community.

The current status of the small boat harbor is in disrepair. The facility has numerous life safety and code violation issues, and is non-functional for the types of vessels that need to fish in the area. In addition, it has no adjacent utilities or area for support services, and is configured for a "Tupperware" fleet with tight turning radii and shallow draught with approaches that can put small boats in conflict with tankers using the fuel facilities at the Port of Adak.

The Adak Reuse Corporation is seeking approximately \$500,000 (Five Hundred Thousand) in financial assistance to immediately provide a safe haven for fishing vessel who use the Port of Adak as their home port. Preliminary engineering and budget range verification is currently in process and will be available shortly. Additional funds will be secured through federal sources to address expansion needs.

The use of funds is projected as follows:

- Immediately complete 2001 repair-engineering to optimize the current small boat harbor to make it as useful as possible for the Adak day-fishing fleet;
- Immediately repair life/safety and code related violations;
- Perform emergency debris removal and maintenance dredging in the existing small boat harbor entrance channel and turning basin;
- Renovate and replace small boat harbor approach ramps, pilings, passenger access areas and floats that are currently non-functional and/or missing or broken; and
- Renovate and replace decking and bull rails.

The Adak Reuse Corporation has worked for over 3 years to establish a new City of Adak under existing state law. That process is nearing completion with a new community vote leading to formal incorporation scheduled for April of this year. Adak's transitional status has not allowed access to normal small boat harbor improvements funds from the US Department of Commerce Economic Development Administration. It has also missed out on fish revenue funds from the State of Alaska that would normally be available to a community that has provided the tax revenues for the State of Alaska. Lack of normal community port development funding has led to further deterioration of the fishing vessel support infrastructure over the last 5 years of Navy environmental remediation of Adak. These facilities must be immediately repaired and rehabilitated and then expanded as soon as possible.

The Adak Reuse Corporation, the Port and the future City appreciate your willingness to consider emergency rehabilitation and expansions support for the small boat needs of Adak. Please call Agafon Krukoff, Mayor of the "pre-incorporation" Adak Community Council, or Mr. Christopher Gates at 907 562-5444 if you have any questions and/or requests for information regarding the need to fix the small boat harbor facilities on Adak.

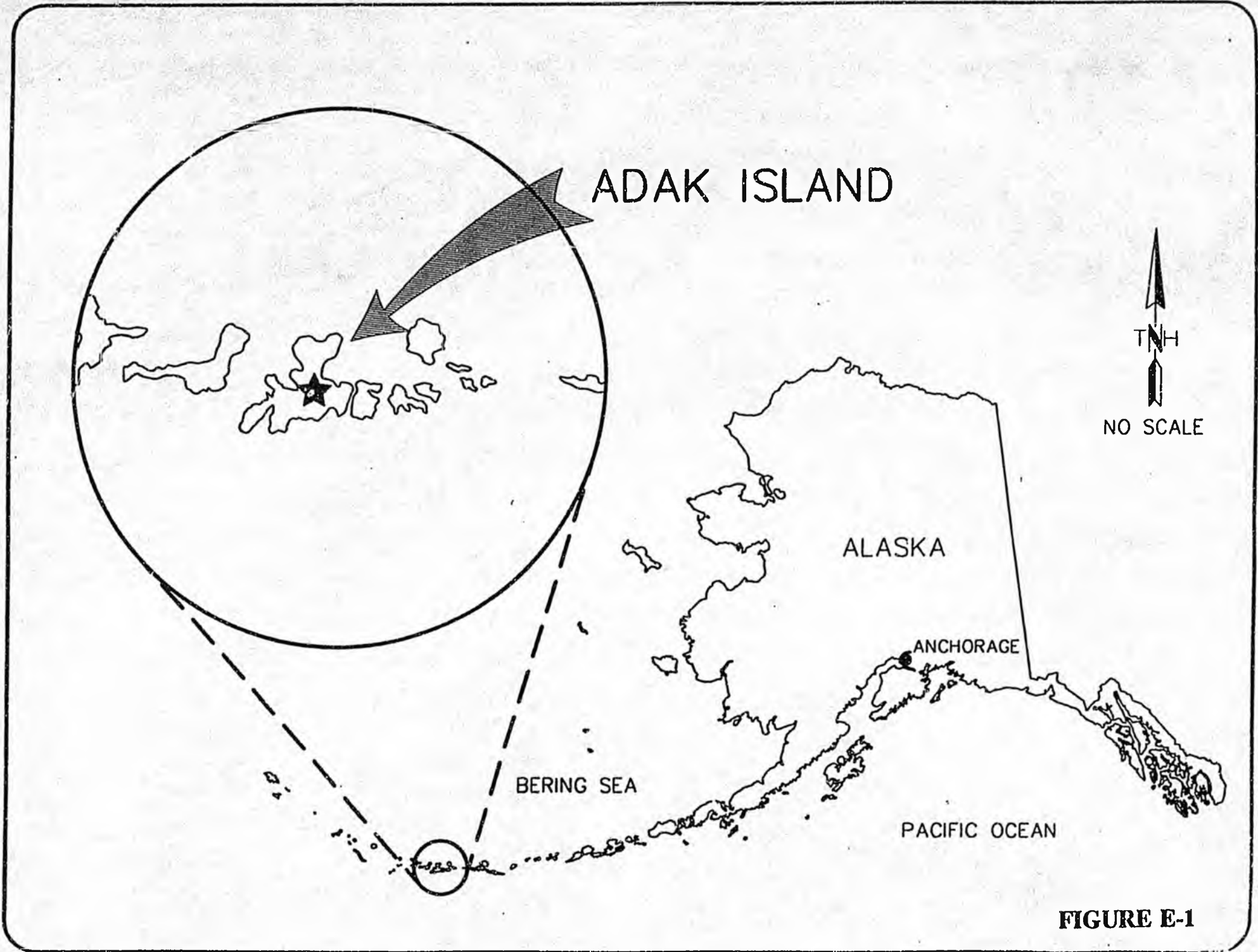

FIGURE E-1

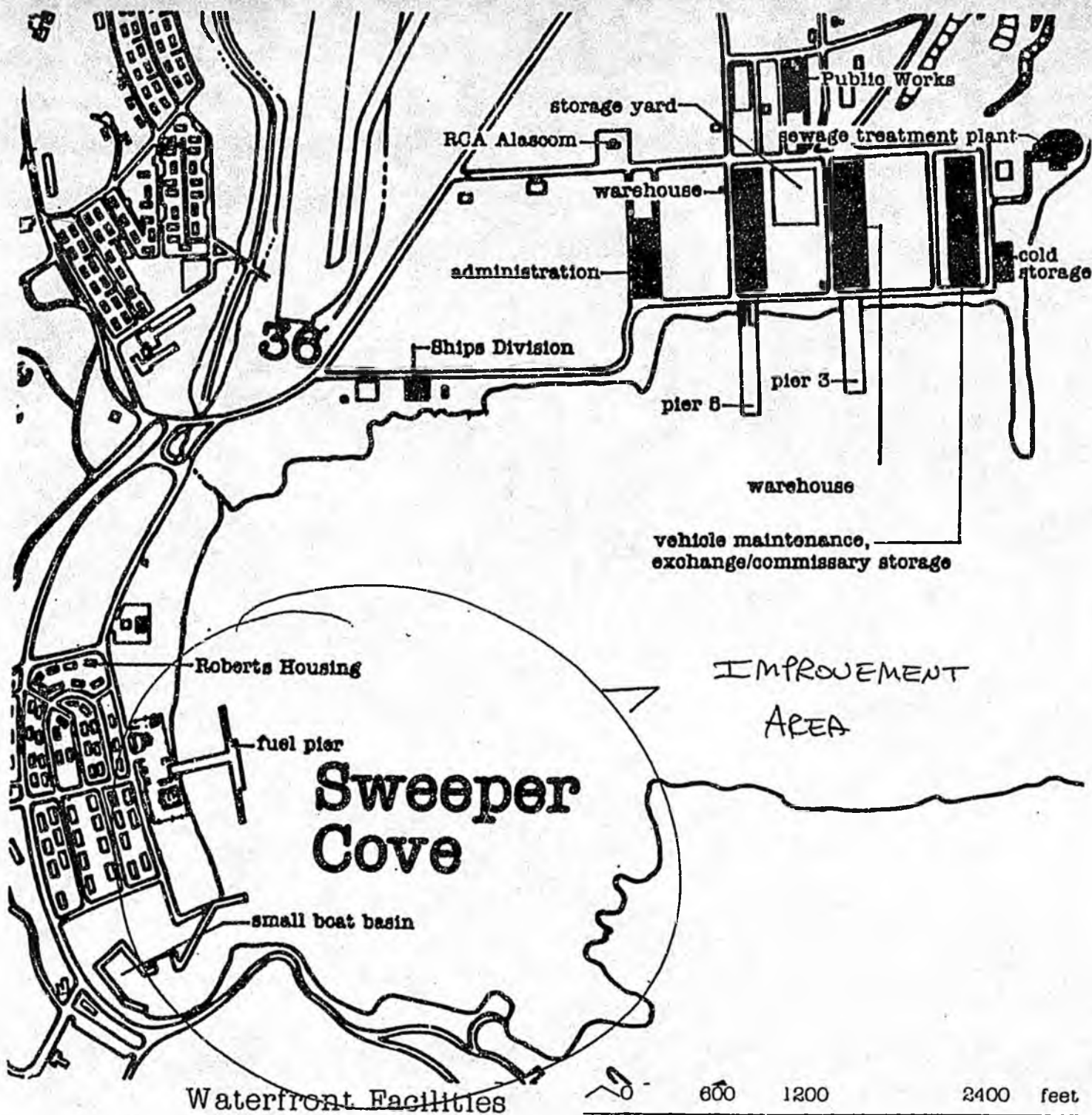

FIGURE IB-3.1

SITE: Mat-Su LIO

COMMITTEE: STRA

DATE: 03-22-01

SUBJECT OF MEETING:

SB 44

UPDATE #:

PLEASE SIGN IN

PLEASE PRINT:

NAME

ADDRESS (MAILING & ZIP)

REPRESENTING

DO YOU WANT

TO TESTIFY?

Y or N

NAME	ADDRESS (MAILING & ZIP)	REPRESENTING	DO YOU WANT TO TESTIFY? Y or N
Tim Anderson		MSB Mayor	SB 44 & 45 Y

AMENDMENT

To: CSSB 111()

Offered By: Senator Elton

Page 2

Amend Section 3:

Line 9: Delete "\$34,627,500" and in its place insert "41,746,500"

Line 23: Insert a new line beneath "Nome 1,000,000"
The new line will read "Juneau 7,119,000"

Page 3

Amend Section 7:

Line 22: Delete "34,627,500" and in its place insert "41,746,500"

Line 25: Delete "34,627,500" and in its place insert "41,746,500"

1 omel \$41,746,500 on line 9 pg 1

Alaska State Legislature

Chairman,
Judiciary Committee

Vice-Chairman,
Administrative Regulations
Revenue Committee

Member,
Transportation Committee
Resources Committee



Senator Robin L. Taylor

State Capitol
Juneau, Alaska 99801-1182
(907) 465-3873
Fax: (907) 465-3922

50 Front Street
Suite 203
Ketchikan, Alaska 99901
(907) 225-8088
Fax: (907) 225-0713

SPONSOR STATEMENT SB 111

Last year we passed legislation that provided for upgrading ports and harbors. Many municipalities were given the funds to upgrade their harbors. The municipalities listed in this bill were not. Before that legislation passed, it had been amended to make these municipalities responsible for issuing the bonding that would provide the funds necessary to make these improvements.

This legislation corrects that provision. These harbors have been neglected by the state and were rated high on the state's deferred maintenance list. They had been on DOT's list time and time again and were always moved to the deferred maintenance list.

It is time to make these municipalities whole. For the last year they have pondered their plight as a result of the old bill, their ports and harbors have continued to deteriorate. This is not responsible management of our ports and harbors. We need to fund the work on DOT's deferred maintenance list and turn these ports and harbors over to the municipalities. We should not be in the ports and harbors maintenance business.

District A:

Hyder • Ketchikan • Kupreanof • Meyers Chuck • Petersburg • Saxman • Sitka • Wrangell
E-mail: Senator_Robin_Taylor@legis.state.ak.us