

**HB**

**175**

Matanuska Electric Co-op:

Funds for Matanuska Electric Co-op are in this bill, obviously because they are part of the Railbelt electric family.

They are also the fastest growing segment of Alaska today and as you have seen in past Capital Budget requests in need of line extension funding to respond to their growing area.



ME

---

## MEMORANDUM

**DATE:** May 6, 2002

**TO:** Tuckerman Babcock  
Director of Governmental & Strategic Affairs

**FROM:** Bob Drake  
Acting Director of Engineering

**SUBJECT:** Transmission & Distribution Upgrades/Improvements

Several transmission and distribution projects have recently been discussed. This memo is intended to provide some very preliminary cost figures for these projects.

### UPGRADE ALASKA INTERTIE FROM KNIK ROAD (CEA's Teeland Substation) TO WILLOW (MEA's Douglas Substation)

Golden Valley Electric Association is evidently proposing this upgrade. It appears the intent is to build a transmission line parallel to one currently owned by MEA, or to upgrade MEA's existing line, and to convert the line from its current 138 kV to 230 kV or 345 kV. If the new line was built and operated at any voltage other than 138 kV, MEA will likely be forced to spend millions of dollars to convert existing facilities to the higher voltage. Improvements to MEA's Stevens Substation would cost approximately \$2,000,000, improvements to MEA's Douglas Substation would cost \$3,000,000 and improvements to our facilities near Teeland Substation would cost another \$2,000,000. Total substation improvements would approach \$7,000,000. However, this assumes the Intertie Operating Committee would allow the higher voltage line to be accessed as it is currently.

Most transmission line owners would not allow a 230 or 345 kV line to be tapped to provide power to distribution substations. Thus a more likely scenario is MEA would be forced to build new transmission lines to connect our Willow (Douglas) and Talkeetna (Stevens) Substations to our existing transmission grid. These lines would need to be operated at 115 kV. The costs to build transmission lines vary, but would likely be at least \$400,000 per mile. The total distance is 26.2 miles, for a cost of \$10,480,000.

## SUBSTATION AND DISTRIBUTION LINE IMPROVEMENTS

At numerous times over the years, MEA has been approached by city officials, community organizations and customers to move substations in Eagle River and Palmer away from the downtown areas. The cost to move these two substations would cost about \$3,500,000 each, for a total of \$7,000,000.

In addition, people in Wasilla, Palmer and Eagle River have long advocated the conversion of existing overhead lines to underground in most all areas, but specifically in the downtown areas. The cost to convert bury existing overhead facilities vary greatly with the nature of the line. A conversion in the Eagle River area last year cost approximately \$125 per foot for a main three-phase circuit. Thus it would easily cost at least \$18,000,000 to bury most lines in the downtown areas of the three communities.

Bb

May 6, 2002

To: Tuckerman Babcock

From: Don Zoerb



Subject: AEA Wheeling Rates

MEA is paying the AEA 5.4 mills per kWh to wheel energy over the Alaska Intertie from Willow to Talkeetna.

MEA receives .38 mills per kWh from the AEA for use of our Hollywood to Willow transmission line as part of the Alaska Intertie.

This is a ratio of about 14:1 for using roughly equivalent line segments (about 20 miles each).

Our contract with AEA provides for periodic adjustment of the rate we receive. MEA has been attempting to adjust this rate to .58 mills per kWh since 1996, but AEA refuses to pay the increased rate.



ALASKA INDUSTRIAL DEVELOPMENT  
AND EXPORT AUTHORITY



813 WEST NORTHERN LIGHTS BLVD. • ANCHORAGE, ALASKA 99503 • 907 / 269-3000 • FAX 907 / 269-3044  
TOLL FREE (ALASKA ONLY) 888 / 300-8534

Alaska Electric Generation & Trans. Co-op  
Attn: Don Stead  
3977 Lake Street  
Homer, AK 99603

# INVOICE

DATE	INVOICE #
11/14/2001	02-40

Due Upon Receipt

Period	DESCRIPTION	MWH	UNIT COST	AMOUNT
October 2001	Energy Usage	368	5.40	1,987.20

RECEIVED  
Payables  
NOV 29 2001  
Homer Electric Assn., Inc.

**Total Due:** \$1,987.20

Remit To:  
Alaska Energy Authority  
813 W Northern Lights  
Anchorage, AK 99503

Accounting Info: Credit E-501-18100-000

*Full*  
*186.90.*  
*Equivalent to .0054/kwh*

(BP)

ALASKA'S FIRST REC INCORPORATED 1941 ENERGIZED 1942



Matanuska Electric  
Association, Inc.

P.O. Box 2929  
Palmer, Alaska 99645  
Phone (907) 745-3231  
Fax (907) 761-9324

ATTN ACCOUNTING  
NAME ALASKA ENERGY AUTHORITY (AIDEA) DATE 4/10/02  
ADDRESS 813 W NORTHERN LIGHTS BLVD  
CITY ANCHORAGE STATE AK ZIP 99503  
WORK ORDER #/JOB ORDER # \_\_\_\_\_

QUANTITY	DESCRIPTION	UNIT PRICE	TOTAL
	Unpaid Balance from Prior Months \$468,729.26		
	Interest on Past Due Balance of \$464,293.19 from Prior Months @ 10.5%		\$4,116.44
	Wheeling Charges Anchorage-Fairbanks Intertie March 2002 FY2002		
	Northbound 5,782,000 @ .00058 = \$3,353.56		
	Teeland to Douglas 135KV Line Surcharge 5,782,000 @ .00000489 = 28.27		
	Total:		\$3,381.83
	Total Current Months Charges Due:		\$7,498.27
	10-456000 \$3,381.83 CE 6900 RC 980 OBJ 20 PRO 2		
	10-419000 \$4,116.44 CE 5660 RC 990 OBJ 20 PRO 2		

QSD 33-MEA 12/99 TERMS: ALL AMOUNTS ARE DUE & PAYABLE WITHIN 30 DAYS FROM INVOICE DATE

MC - 16632

AEA is paying @ .00038 RATE

Alaska State Legislature

SESSION ADDRESS:  
State Capitol  
Juneau, Alaska 99801-1182  
Phone (907) 465-2693  
Toll Free 800-463-2693  
Fax 907-465-3835



INTERIM ADDRESS:  
35477 Suite 101-B Spur Hwy  
Soldotna, Alaska 99669  
Phone 907-260-5236  
Fax 907-260-3044

Representative Ken Lancaster  
District 8

May 6, 2002

MEMORANDUM

To: Senator John Cowdery  
Chairman, Senate Transportation Committee

From: Representative Ken Lancaster

Subject: House Bill 175 – “An Act making an appropriation to the Alaska Energy Authority to secure repayment of bonds for power and intertie projects”

I would like to request a hearing as soon as possible for the above mentioned legislation. Attached is a copy of the bill and backup material for the legislation.

I look forward to this being scheduled as soon as possible and if you need further information, please let me know.

Thank you.

SESSION ADDRESS:  
State Capitol  
Juneau, Alaska 99801-1182  
Phone (907) 465-2693  
Toll Free 800-463-2693  
Fax 907-465-3835



INTERIM ADDRESS:  
35477 Suite 101-B Spur Hwy  
Soldotna, Alaska 99669  
Phone 907-260-5236  
Fax 907-260-3044

Representative Ken Lancaster  
District 8

Sponsor Statement

House Bill 175

"An Act making an appropriation to the Alaska Energy Authority to secure repayment of bonds for power and intertie projects"

This bill will allow the railbelt energy fund dollars to be appropriated to the Alaska Energy Authority for investment to secure repayment of bonds issued by the authority.

There will be \$20,300,000 allocated to upgrade and extend the Anchorage-Fairbanks intertie to the Teeland Station.

The following grants will be named:

Homer Electric Association	Replacement Power Supply For Seldovia	\$ 2,000,000
Anchorage Municipal Light and Power	Eklutna project transmission line upgrade	\$19,300,000
Golden Valley Electric	Line Extension	\$ 872,000
Matanuska Electric Assn.	Line Extension	\$ 500,000

Once the bonds have been repaid, Alaska Industrial Development and Export Authority (AIDEA) will develop a prioritized list of energy projects that can be funded from the revenue stream from the funds appropriated. This should be a continuing process.

Dated: 5/3/02

**Subject: House Votes Approval of Intertie Projects**

**Date:** Fri, 03 May 2002 10:37:58 -0800

**From:** Dan Saddler <Dan\_Saddler@legis.state.ak.us>

**Organization:** House Majority

Alaska State Legislature  
House of Representatives  
Representative Ken Lancaster

FOR IMMEDIATE RELEASE: May 3, 2002  
CONTACT: Rep. Ken Lancaster, (907) 465-2693

## **House Votes Approval of Intertie Projects**

### **HB 175 Finances Needed Railbelt Energy Grid Work**

(JUNEAU) – The House today passed legislation authorizing a financing mechanism aimed at funding \$43 million in rural electrical intertie projects to improve utility service to Railbelt communities.

Sponsored by Rep. Ken Lancaster (R-Soldotna), House Bill 175 represents an effort to bring cleaner, more reliable energy to residents of the Railbelt, he said.

“Many areas in Alaska have been waiting a long time for these projects to expand the grid and connect them with generation and transmission facilities,” said Lancaster, who has 25 years experience serving on various utility boards and working with the power industry around the state.

The money would fund several long-anticipated projects, Lancaster said:

- \$20.3 million for a three-phase power line from Mile 100 to Mile 133 of the Parks Highway
- \$2 million for power generation and transmission line upgrades in Seldovia
- \$19.3 million to replace the Eklutna project power transmission line in Anchorage
- \$500,000 for Matanuska Electric Association line extension in the Matanuska-Susitna Borough
- \$872,000 for Golden Valley Electric Association line extension in Interior Alaska.

The bill also eliminates the controversial Railbelt Energy Fund by transferring it into the assets of the Alaska Industrial and Export Authority. AIDEA will “securitize” the money, creating a revenue stream so that it can sell revenue bonds and pay the debt service with the proceeds from that securitization.

As those bonds are paid off, AIDEA will issue new bonds to fund other priority energy projects, repeating the cycle and continuing to use the funds to provide reliable energy for Alaskans, Lancaster said.

“By improving electrical service in these communities, the projects funded by this bill will improve the local economies and the quality of life for thousands of Alaskans, and I’m pleased to have the House’s support in this effort,” Lancaster said.

House Bill 175 moves next to the Senate for consideration.

###



# Homer Electric Association, Inc.

Corporate Office  
3977 Lake Street  
Homer, Alaska 99603-7680  
Phone (907) 235-8551  
FAX (907) 235-3313

Central Peninsula Service Center  
280 Airport Way  
Kenai, Alaska 99611-5280  
Phone (907) 283-5831  
FAX (907) 283-7122

January 17, 2002

RECEIVED  
JAN 23 2002

The Honorable Ken Lancaster  
Alaska State Legislature  
State Capitol (MS-3100)  
Juneau, Alaska 99801-1182

Dear Representative Lancaster:

We are very pleased to hear you are committing to another term. As state legislator, you have been very effective in representing the Kenai Peninsula. We greatly appreciate your continued support for Homer Electric's power projects.

A recent cost estimate update on the Regional Power Project for Seldovia, Port Graham and Nanwalek shows we are in need of funds beyond Senator Stevens' \$2 million grant. The following is a breakdown of costs:

Kachemak Submarine Cable	\$2,617,259
Seldovia Generation Replacement	\$1,104,400
Port Graham Stand-by Generation (new project)	\$ 255,000
Sub total	\$3,976,659
minus federal grant	< \$2,000,000 >
Net shortfall in funding	\$1,976,659

I look forward to working with you during the next legislative session in hopes you will be able to help with the budget shortfall. Plans are currently being made for our visit to Juneau. We look forward to visiting with you while there.

Sincerely,

HOMER ELECTRIC ASSOCIATION, INC.

N. L. Story  
General Manager



# Homer Electric Association, Inc.

Corporate Office  
3977 Lake Street  
Homer, Alaska 99603-7680  
Phone (907) 235-8551  
FAX (907) 235-3313

Central Peninsula Service Center  
280 Airport Way  
Kenai, Alaska 99611-5280  
Phone (907) 283-5851  
FAX (907) 283-7122

## Seldovia Generator Plant Rebuild

**PROJECT DESCRIPTION:** Rebuild existing generation facility in Seldovia, including the building, generators, switchgear, and associated distribution equipment.

**ESTIMATED COST:** \$1,104,400

**DISCUSSION:** Although the area south of Kachemak Bay is normally served from Hatfield Substation (via Homer Spit and underwater Kachemak Bay power cable), service is frequently interrupted by tree fall during storms. In good weather this area is accessible only by air or boat. During storms the area is not safely accessible, therefore outage response by line crews is typically delayed by as many as several days. To rapidly restore power to the area (with approximately 700 consumers), HEA maintains a resident power plant operator who is on call "24/7" to operate the Seldovia generator plant during outages.

The Seldovia generation and electrical distribution system was acquired from the local electric utility in 1964. In 1970 and 1981 additional generators were installed in the generator plant. These generators are 1950's vintage and require constant attention while running. The switchgear is of similar age. A recent review has determined the building to have several problems and that it is not economically repairable.

This work plan item proposes to provide a functionally new diesel generator plant by executing the following tasks:

- Demolition of the existing building
- Removal of generators and switchgear
- Repair and reinforcement of the existing foundation
- Construction of a new building and building systems
- Installation of new generator, switchgear, and the means to remotely operate and control this equipment
- Relocation of the outdoor fuel tank to indoors
- Replacement of transformer which links the generator bus to HEA's 25 kV distribution system



# Homer Electric Association, Inc.

Corporate Office  
3977 Lake Street  
Homer, Alaska 99603-7680  
Phone (907) 235-8551  
FAX (907) 235-3313

Central Peninsula Service Center  
280 Airport Way  
Kenai, Alaska 99611-5280  
Phone (907) 283-5831  
FAX (907) 283-7122

## Port Graham Standby Generator

**PROJECT DESCRIPTION:** Provide standby generation capabilities for this remote region of the service area.

**ESTIMATED COST:** \$255,000

**DISCUSSION:** The villages of Port Graham and Nanwalek are connected by an 8.5 mile single-phase line, which comprises the most rugged and inaccessible portion of HEA's distribution system. This line is subject to storm-related outages, the restoration of which can take several days to accomplish. This project, still in the conceptual phase, proposes to provide an alternate standby means to restore power to these villages. Project will take place in the Cannery at Port Graham.

**Stand Alone Generator:** Stand Alone Three-Phase Generator "star-connected" - The star connection would permit a standard "off-the-shelf" 3-phase generator to reliably serve a single phase load without damage.

Additional considerations include various ways to site and provide fuel to a stand-alone generator:

- Install generator in existing Spare Bay in Cannery Generator Room
- Install generator in Separate Out-Building - this could be located near Cannery Generators or elsewhere at Port Graham
- Additional Diesel Fuel Tank
- Add piping and metering to existing Cannery Fuel Storage

As noted above, the project would install a separate generator in the Cannery building. HEA plans to conduct a study, which will consider installed cost, operations costs, ease and safety of operation with preference given to remote control, maintenance costs, ownership and lease issues.



# Homer Electric Association, Inc.

**Corporate Office**  
3977 Lake Street  
Homer, Alaska 99603-7680  
Phone (907) 235-8551  
FAX (907) 235-3313

**Central Peninsula Service Center**  
280 Airport Way  
Kenai, Alaska 99611-5280  
Phone (907) 283-5831  
FAX (907) 283-7122

## Submarine Cable Replacement

**PROJECT DESCRIPTION:** Replace aging 25kV submarine cable which supplies power to the south side of Kachemak Bay and approximately 700 consumers.

**ESTIMATED COST:** \$2.4 million

**DISCUSSION:** Dryden & LaRue, Inc. was engaged to complete an engineering study on the South Kachemak Bay power supply situation. They considered three alternatives (cable replacement, construct overhead line from Bradley Lake, and local generation), and recommend replacing the submarine cable. It is the most cost effective option.

As the existing cable was operating beyond it's expected life, a new submarine cable was ordered, shipped and ultimately installed the week of November 5, 2001.

Project estimated to cost \$2.4 million (actual cost \$2,401,782)

Additional work to tie newly installed submarine cable to the HEA distribution system at the Homer Spit. (actual cost \$215,477)

Submarine cable installation	\$2,401,782
Termination work	\$215,477
<b>Total</b>	<b>\$2,617,259</b>

## Anchorage/Fairbanks Transmission Line Blockage

Current Situation: The interconnected transmission system between Anchorage and Fairbanks is presently owned by four entities: (1) Chugach Electric owns the 230 kV system from Anchorage to Teeland, (2) Matanuska Electric owns the 26-mile 115kv system from Teeland to Douglas (3) the Alaska Energy Authority owns the 190-mile 230 kV system from Douglas substation to Healy and is in the process of constructing a second 230 kV loop, and (4) Golden Valley Electric owns the 138 kV system from Healey to Fairbanks and is in the process of constructing a second 230kV loop. Because of the 26-mile 115 kV system bottleneck, the overall system has a transfer capability of only 70 mw of power between Anchorage and Fairbanks and the line losses across this short stretch are quite high.

Project Description: Construct a new line connecting the Chugach system (Lake Lorraine) to the State system at Douglas substation. The upgrade would double the transfer capacity between Anchorage and Fairbanks and significantly reduce line loss. From Douglas Substation on Douglas Creek, the route would follow a southeast course, generally paralleling the Parks Highway to the Nancy Lake Substation. From the Nancy Lake Substation, the route would extend due south to the Little Susitna substation on the Little Susitna River. The route would then turn to a southwest course and extend approximately 10 miles to a point southwest of Big Lake. From this point the route would follow a generally southeast course to the Lake Lorraine Substation located on the West Side of Knik Arm. Total length of the system would be approximately 26 miles consisting of Cortend steel guyed towers and conductored to operate at 230 kV.

Cost of the system: Total cost of the system based on unit costs anticipated for the Northern Latertie project presently under construction is \$17.2 million.

Benefits: Upgrade of the system would double the transfer capacity of the transmission line between Anchorage and Fairbanks. In addition to the economy energy transfer capability of the line, reserve capacity in the two load centers could be reduced, and line efficiency would be significantly increased. Future gas availability in Fairbanks could allow for siting of generation facilities or co-generation facilities in Fairbanks that would provide generation additions in the north with transfer capability south.

## Railbelt Transmission Line Upgrade Twenty-six mile upgrade to 230 kv

Current Situation: The interconnected transmission system between Anchorage and Fairbanks is presently owned by four entities: (1) Chugach Electric owns the 230 kv system from anchorage to Teeland, (2) Matanuska Electric owns the 26 mile 115kv system from Teeland to Douglas (3) the Alaska Energy Authority owns the 190 mile 230 kv system from Douglas substation to Healy and is in the process of constructing a second 230kv loop, and (4) Golden Valley Electric owns the 138 kv system from Healey to Fairbanks and is in the process of constructing a second 230kv loop. Because of the 26 mile 115 kv system, the overall system has a transfer capability of only 70 mw of power between Anchorage and Fairbanks and the line losses across this short stretch are quite high.

Proposal Construct a new line connecting the Chugach system (Lake Lorraine) to the State system at Douglas substation. The upgrade would double the transfer capacity between Anchorage and Fairbanks and significantly reduce line loss. From Douglas Substation on Douglas Creek, the route would follow a southeast course, generally paralleling the Parks Highway to the Nancy Lake Substation. From the Nancy Lake Substation, the route would extend due south to the Little Susitna substation on the Little Susitna River. The route would then turn to a southwest course and extend approximately 10 miles to a point southwest of Big Lake. From this point the route would follow a generally southeast course to the Lake Lorraine Substation located on the West Side of Knik Arm. Total length of the system would be approximately 26 miles consisting of Cortend steel guyed towers and conductored to operate at 230 kv.





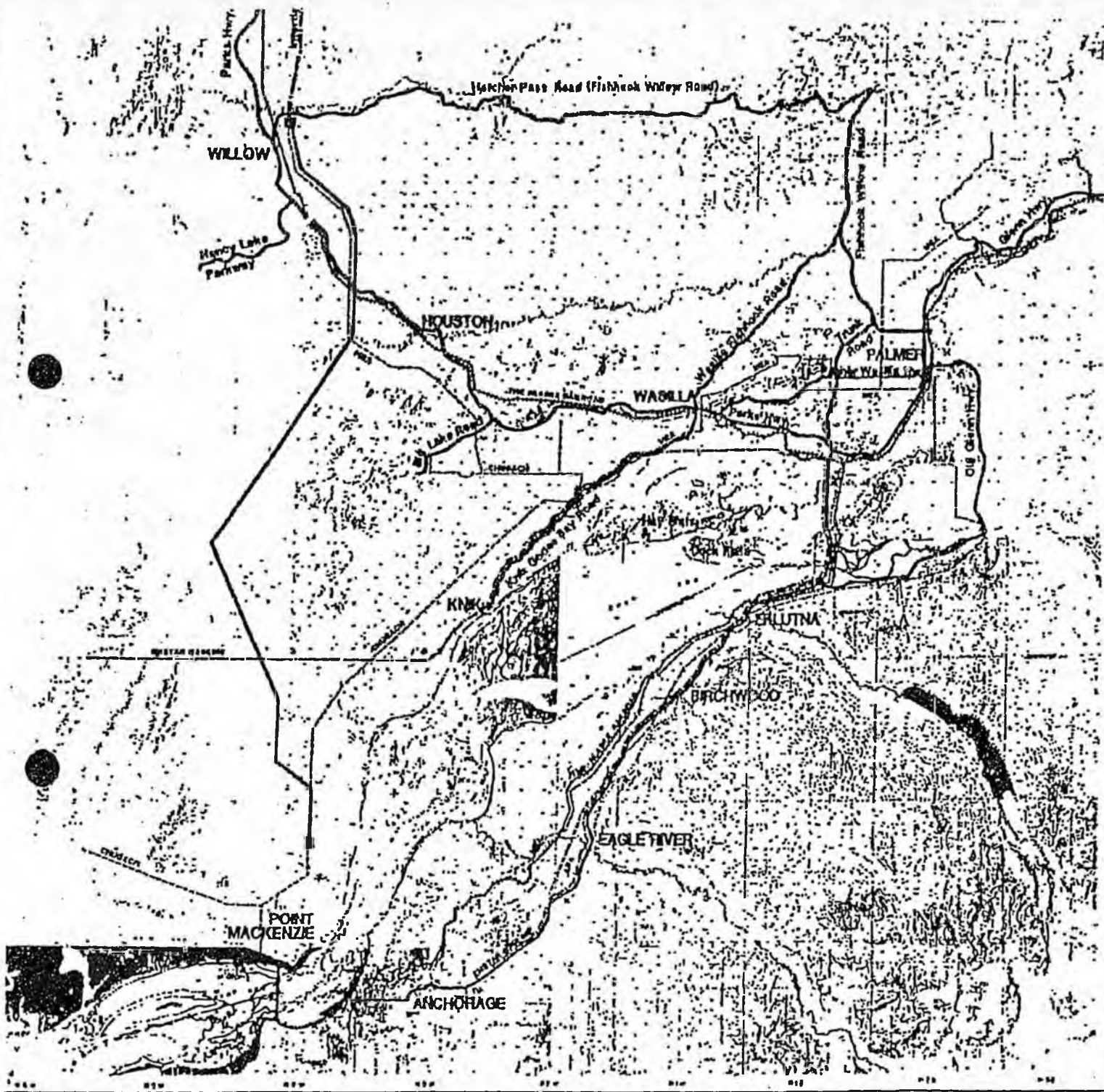

Cost of the system: Total cost of the system based on unit costs anticipated for the Northern Intertie project presently under construction is \$17.2 million.

Benefits: Upgrade of the system would double the transfer capacity of the transmission line between Anchorage and Fairbanks. In addition to the economy energy transfer capability of the line, reserve capacity in the two load centers could be reduced, and line efficiency would be significantly increased. Future gas availability in Fairbanks could allow for siting of generation facilities or co-generation facilities in Fairbanks that would provide generation additions in the north with transfer capability south.



DATA SOURCE  
 - USGS 1:250,000 Topographic Map  
 - 1974

**LEGEND**

-  Major Highways & Roads
-  Interdo
-  Electric Gasline
-  Existing Transmission Lines
-  Railroad
- 



**ALASKA POWER AUTHORITY**  
 ALASKA - FAIRBANKS DISTRICT  
**PROPOSED ROUTE**  
 DOUGLAS - LAKE  
 LORRAINE

11022 2000 07

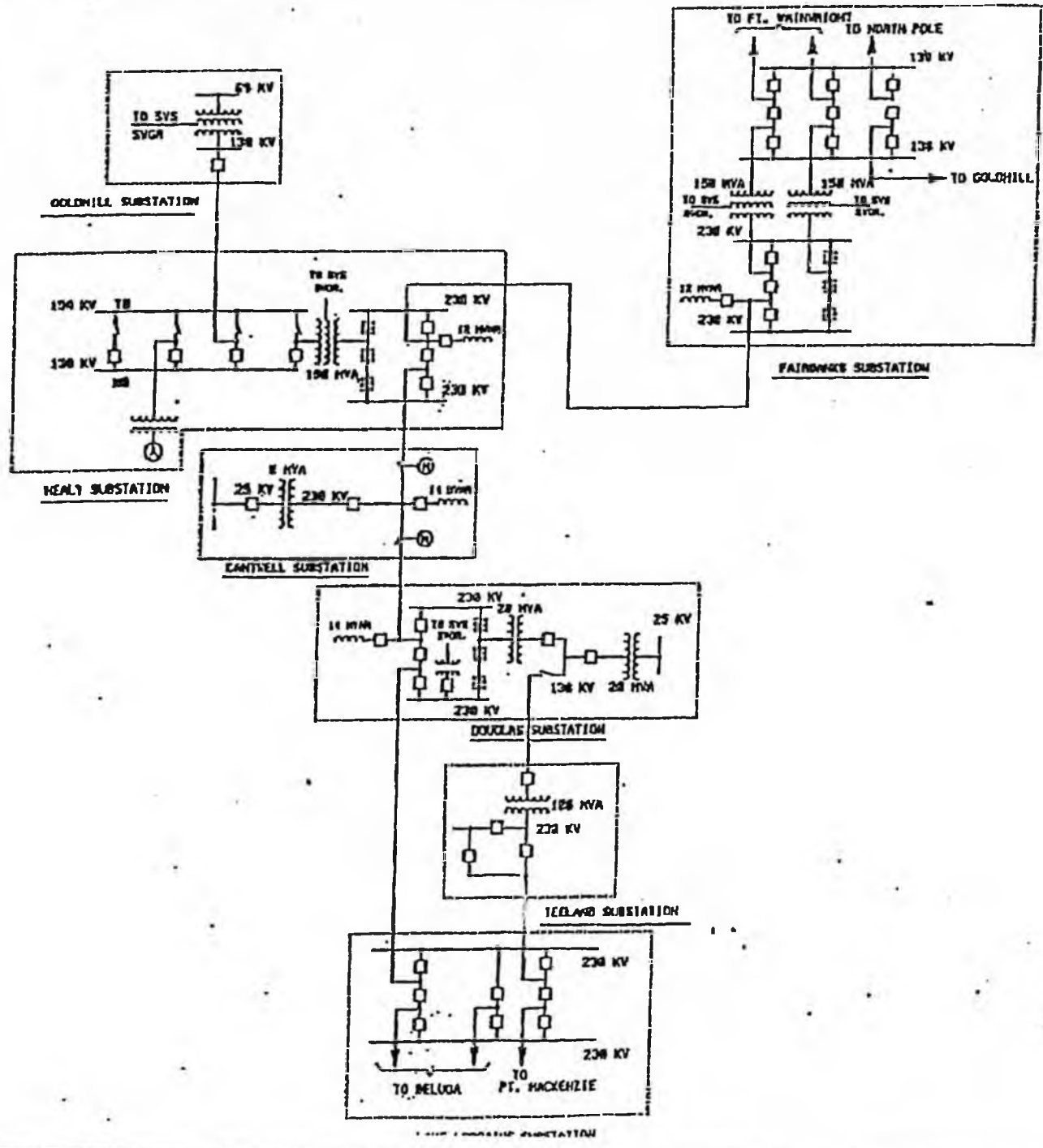

ALASKA POWER AUTHORITY  
 ANCHORAGE - FAIRBANKS  
 INTERTIE  
 SYSTEM DIAGRAM  
 230 KV

March 13, 2001

## 230 kilovolt Conversion of the Anchorage to Fairbanks Intertie

The existing intertie from Willow to Healy is constructed to operate at 345 kilovolts and is currently operating at 138 kilovolts. The Northern Intertie will be constructed to operate at 230 kilovolts and will operate in parallel with the existing 138 kV line between Healy and Fairbanks. Adding a new 26 mile 230 kV line from the Douglas substation in Willow to Teeland Substation in Wasilla would provide a 230 kV source to the north.

### CAPITAL COSTS:

Cost Estimate for Fairbanks to Healy 230 kV Conversion	
Transmission Line Design, Permitting, Construction	
26 miles at \$520,000 per mile	\$ 13,520,000.
<u>Conversions and transformers at multiple substations</u>	<u>\$ 11,008,000</u>
Total costs of 230 kV Conversion	\$ 24,528,000

### BENEFITS:

#### Increased Transmission Capacity

**Purchases from Anchorage (current):** The transfer capacity in to Healy would increase from 70 megawatts to approximately 130 megawatts after the conversion to 230 kilovolts. The increase in transfer capacity would provide access to new or existing gas-fired cogeneration in Anchorage.

**Sales to Anchorage (Post gas-pipeline):** Power can flow either direction on transmission lines. The transmission capacity increase will allow for delivery of 130 megawatts of North Slope gas-fired power to Anchorage, after construction of the gas pipeline.

#### Reduced Transmission Line Losses

**Teeland to Douglas Line:** From operation of a new parallel path at 230 kV

**Douglas to Healy:** From voltage conversion from 138 kV to 230 kV

**Healy to Fairbanks:** From Northern Intertie parallel path and conversion of the Northern Intertie to operate at 230 kV.

**Reliability Increases – Second Line Douglas to Teeland:** The addition of a second circuit will improve reliability across this section of line which is prone to line failures.

**Reconstruction Benefits:** The addition of the second line will allow for maintenance of either line while maintaining power delivery.

## 230KV Upgrade Cost Estimate

4/3/01

## BUSWORK

Item	Quantity	Unit	Material Cost	Mat Cost Per Unit	Installation Cost	Inst Cost Per Unit	Total Cost	
INSULATOR, STATION POST, 230KV	204	ea	\$180.00	\$38,760.00	\$355.00	\$72,420.00	\$111,180.00	
INSULATOR, STATION POST, 138KV	42	ea	\$105.00	\$4,410.00	\$355.00	\$14,910.00	\$19,320.00	
INSULATOR, SUSPENSION, 230KV	115	ea	\$180.00	\$20,700.00	\$540.00	\$62,100.00	\$82,800.00	
INSULATOR, SUSPENSION, 138KV	6	ea	\$120.00	\$720.00	\$540.00	\$3,240.00	\$3,960.00	
SURGE ARRESTER, STATION CLASS, 230KV MCOV	20	ea	\$1,750.00	\$35,000.00	\$1,680.00	\$33,600.00	\$68,600.00	
SURGE ARRESTER, STATION CLASS, 138KV MCOV	8	ea	\$1,010.00	\$8,080.00	\$1,680.00	\$13,440.00	\$21,520.00	
CONDUCTOR, PIPE, 4" ALUMINUM, SCHEDULE 40	2000	lf	\$12.00	\$24,000.00	\$13.00	\$26,000.00	\$50,000.00	
CONDUCTOR, PIPE, 2" ALUMINUM, SCHEDULE 40	2000	lf	\$8.00	\$16,000.00	\$13.00	\$26,000.00	\$42,000.00	
CONDUCTOR, CABLE	1000	lf	\$2.00	\$2,000.00	\$6.00	\$6,000.00	\$8,000.00	
PIPE CONNECTORS, MISC	500	ea	\$15.00	\$7,500.00	\$43.00	\$21,500.00	\$29,000.00	
CABLE CONNECTORS, MISC	100	ea	\$35.00	\$3,500.00	\$16.00	\$1,600.00	\$5,100.00	
TOTALS					\$160,670.00		\$280,810.00	\$441,480.00

230KV Upgrade Cost Estimate

4/3/01

Item	Quantity	Unit	Material Cost	Installation Cost	Total Cost
EQUIPMENT	1	lump	\$4,080,500.00	\$662,880.00	\$4,743,380.00
STRUCTURES	1	lump	\$307,395.00	\$456,632.00	\$783,107.00
BUSWORK	1	lump	\$160,670.00	\$280,810.00	\$441,480.00
FOUNDATIONS	1	lump	\$780,192.00	\$815,410.00	\$1,595,602.00
GROUNDING	1	lump	\$31,570.00	\$197,100.00	\$228,670.00
PROTECTIVE RELAYS	1	lump	\$250,000.00	\$120,000.00	\$370,000.00
CONDUIT AND CABLES	1	lump	\$289,500.00	\$156,000.00	\$445,500.00
SITE PREPARATION	600000	sf	\$1.50	\$1.00	\$1,500,000.00
CRUSHED ROCK	600000	sf	\$1.00	\$0.50	\$900,000.00
<b>TOTALS</b>					<b>\$11,007,739.00</b>

## 230KV Upgrade Cost Estimate

4/3/01

EQUIPMENT Item	Quantity	Unit	Material Cost	Mat Cost Per Unit	Installation Cost	Inst Cost Per Unit	Total Cost
POWER TRANSFORMER: 230/138KV, 150MVA	1	ea	\$750,000.00	\$750,000.00	\$126,780.00	\$126,780.00	\$876,780.00
POWER TRANSFORMER: 230/138KV, 100MVA	1	ea	\$650,000.00	\$650,000.00	\$126,780.00	\$126,780.00	\$776,780.00
POWER TRANSFORMER: 230/24.9KV, 12/16/20MVA	1	ea	\$380,000.00	\$380,000.00	\$72,450.00	\$72,450.00	\$452,450.00
POWER TRANSFORMER: 230/24.9KV, 6.25MVA	2	ea	\$345,000.00	\$690,000.00	\$52,450.00	\$104,900.00	\$794,900.00
POWER CIRCUIT BREAKERS 230KV, SF6, 1200 AMP	10	ea	\$89,000.00	\$890,000.00	\$10,920.00	\$109,200.00	\$999,200.00
POWER CIRCUIT BREAKERS 138KV, SF6, 1200 AMP	4	ea	\$80,000.00	\$320,000.00	\$10,920.00	\$43,680.00	\$363,680.00
SWITCH, GOAB, VERTICAL BREAK, 230KV, 1200 AMP	20	ea	\$16,500.00	\$330,000.00	\$3,120.00	\$62,400.00	\$392,400.00
SWITCH, GOAB, VERTICAL BREAK, 138KV, 1200 AMP	4	ea	\$12,500.00	\$50,000.00	\$3,120.00	\$12,480.00	\$62,480.00
SWITCH, GOAB, V-BREAK, 230KV, 1200 AMP, LIVE_BREAK WITH MOTOR OPERATOR	1	ea	\$20,500.00	\$20,500.00	\$4,210.00	\$4,210.00	\$24,710.00
TOTALS					\$4,080,500.00	\$662,880.00	\$4,743,380.00

## 230KV Upgrade Cost Estimate

4/3/01

## STRUCTURES

Item	Quantity	Unit	Material Cost	Mat Cost Per Unit	Installation Cost	Inst Cost Per Unit	Total Cost
230KV DEAD END STRUCTURE (SINGLE BAY)	5	ea	\$12,960.00	\$64,800.00	\$12,868.00	\$64,340.00	\$129,140.00
230KV SWITCH STAND	21	ea	\$3,055.00	\$64,155.00	\$4,130.00	\$86,730.00	\$150,885.00
230KV THREE PHASE BUS SUPPORT	21	ea	\$2,130.00	\$44,730.00	\$4,112.00	\$86,352.00	\$131,082.00
230KV SINGLE PHASE BUS SUPPORT	63	ea	\$1,590.00	\$100,170.00	\$2,310.00	\$145,530.00	\$245,700.00
138KV DEAD END STRUCTURE (SINGLE BAY)	2	ea	\$9,970.00	\$19,940.00	\$9,360.00	\$18,720.00	\$38,660.00
138KV SWITCH STAND	4	ea	\$1,765.00	\$7,060.00	\$3,410.00	\$13,640.00	\$20,700.00
138KV THREE PHASE BUS SUPPORT	4	ea	\$1,635.00	\$6,540.00	\$3,400.00	\$13,600.00	\$20,140.00
138KV SINGLE PHASE BUS SUPPORT	12	ea	\$1,590.00	\$19,080.00	\$2,310.00	\$27,720.00	\$46,800.00
TOTALS				\$307,395.00		\$456,632.00	\$783,107.00

## 230KV Upgrade Cost Estimate

4/3/01

FOUNDATION Item	Quantity	Unit	Material Cost	Mat Cost Per Unit	Installation Cost	Inst Cost Per Unit	Total Cost
FOUNDATION FOR TRANSFORMER, OIL CONTAINMENT	5	ea	\$78,700.00	\$393,500.00	\$72,450.00	\$362,250.00	\$755,750.00
FOUNDATION FOR BREAKER	14	ea	\$1,735.00	\$24,290.00	\$2,150.00	\$30,100.00	\$54,390.00
FOUNDATION FOR BUS SUPPORT, SWITCH, ETC	175	ea	\$1,918.00	\$335,825.00	\$2,310.00	\$404,250.00	\$740,075.00
FOUNDATION FOR DEAD END STRUCTURE	9	ea	\$2,953.00	\$26,577.00	\$2,090.00	\$18,810.00	\$45,387.00
TOTALS				\$780,192.00		\$815,410.00	\$1,595,602.00

230KV Upgrade Cost Estimate

4/3/01

GROUNDING Item	Quantity	Unit	Material Cost	Mat Cost Per Unit	Installation Cost	Inst Cost Per Unit	Total Cost
CONDUCTOR, GROUND	5000	lf	\$1.00	\$5,000.00	\$12.00	\$60,000.00	\$65,000.00
CONDUCTOR, FLEXIBLE COPPER BRAID	28	ea	\$65.00	\$1,820.00	\$75.00	\$2,100.00	\$3,920.00
GROUND RODS	200	ea	\$25.00	\$5,000.00	\$500.00	\$100,000.00	\$105,000.00
GROUND CLAMP, BRONZE	200	ea	\$30.00	\$6,000.00	\$35.00	\$7,000.00	\$13,000.00
GROUNDING PLATFORM	50	ea	\$275.00	\$13,750.00	\$560.00	\$28,000.00	\$41,750.00
TOTALS					\$31,570.00	\$197,100.00	\$228,670.00

## Eklutna Project Transmission Line Replacement

This is a request for replacing the existing Eklutna Hydroelectric power plant transmission line, which is part of a critical Railbelt transmission network and directly serves Municipal Light & Power (ML&P), Chugach Electric Association (CEA) and Matanuska Electric Association (MEA).

It is a 28-mile line that was constructed in the 1950's as part of the Eklutna Hydroelectric Project. The transmission line follows an easement to the West of the Glenn Highway and the Old Glenn Highway, which runs from Anchorage to Palmer. The line directly ties generation sources from Anchorage to the Eklutna Hydroelectric Plant. It also serves as the alternate connection that links ML&P to CEA's transmission system and provides electrical energy to a significant portion of MEA's customers that are connected to substations off the line.

Recently, detailed inspections of the Eklutna Transmission line, brought about by repairs that were made to sections of the line lost in last year's avalanche, show that most of the line is aged and in bad condition, and will require significant refurbishment.

Currently, the owners (ML&P, CEA & MEA) are reviewing replacement and refurbishment options of the Eklutna system. For example: new design and replacement costs for just the oldest section of the line, which extends from the Eklutna plant to the first MEA substation in Eagle River (DOW), are estimated at \$6,000,000.

In addition, the Eklutna transmission line crosses the Kink River on the old, unused bridge. In the past, this bridge has been slated for demolition since it only serves foot traffic and is in disrepair. A new river crossing is necessary in order to refurbish or replace the existing transmission line and enable demolition of the old bridge.

The requirements of this project would include a new double-circuit, 230 kV insulation line design that will replace the existing wood structures with more aesthetic frameworks. It will be more considerate of avalanche problems and provide better seismic resistance. It will have the capability of transferring twice as much power, provide more redundancy and more reliability to both Anchorage and Palmer.

The new line design will extend an additional 10-miles and connect to the Southern portion of the Anchorage - Fairbanks Intertie. This will increase the reliability of MEA's current system by providing redundant circuitry and reliability.

The investment would provide significant and needy improvements to the Anchorage area and would benefit residents for 50-years or more.

The cost to replace the entire Eklutna transmission line, to include a new river crossing, and redundancy to both ML&P and CEA's system, is estimated at \$25,000,000.

Repairs to the existing equipment are already being scheduled in order to retain the system's integrity. Therefore, it is of the essence that decisions are made on whether to repair or refurbish the existing transmission line.

- Construction could start as early as 2002
- Estimated total cost of the replacement project:
  - Design - \$3,750,000
  - Construction - \$21,250,000