

SB

67

SFIN

FILE

SENATE FINANCE COMMITTEE REPORT

DATE: 2/10/99

FURTHER: 5/3/99

Date of 5-Day Notice: _____
(in accordance with Uniform Rule 23)

DATE TURNED
IN TO OFFICE: 3 May 1999

Finance Committee considered SENATE BILL NO. 67

"An Act relating to taxation, including taxation of income of individuals, estates, and trusts; and providing for an effective date."

and recommends:

- be **replaced** with _____ CS _____ (_____)
- adopt **previous** _____ CS _____ (_____)
- attached amendment(s)
- adopt Letter of Intent by _____ Committee
- further referral to the _____ Committee

- Senate Bill:**
- same title
 - new title
- House Bill:**
- same title
 - technical title
 - new: SCR# _____

SIGNING DO PASS	DP	OTHER RECOMMENDATIONS	NR	DNP	AM
<i>Pat Kelly</i> <i>to allow gov jobs vote</i>	✓	<i>Staff et al</i>		✓	
		<i>David Brien</i>		✓	
		<i>Cal Adams</i>		X	
		<i>James Crowley</i>		X	
		<i>Gov. Wilbur</i>		✓	
		<i>Chris D. Lewis</i>		✓	
Co-Chair:		Co-Chair: <i>Adrian</i>		✓	
Co-Chair:		Co-Chair: <i>David Farrell</i>		✓	

NEW FISCAL NOTE(S):

Department	Date	Zero	Fiscal

PREVIOUS FISCAL NOTE(S):*

Department	Date	Zero	Fiscal
<i>Rubino</i>	<i>4/8/99</i>		<i>1156.7</i>

APPROPRIATION -- no fiscal note

*include fiscal notes accompanying Governor's bill

FISCAL NOTE

STATE OF ALASKA
1999 LEGISLATIVE SESSION

5/3/99

Revision Date/Time (Note if correction) _____ Dept. Affected No. 1
 Title Alaska Credit Individual Income Tax BRU Bill Version: SB 67
 Component (S) Publish Date: 2/10/99
 Sponso. Rules
 Requester Governor Component Serial No. 113

Expenditures/Revenues (Thousands of Dollars)

Note: Amounts do not include inflation unless otherwise noted below.

OPERATING EXPENDITURES	FY 2000	FY 2001	FY 2002	FY 2003	FY 2004	FY 2005
Personal Services	681.7	1,722.4	2,500.8	2,506.5	2,506.5	2,506.5
Travel	34.4	42.5	75.2	75.5	75.5	75.5
Contractual	247.8	616.1	819.9	820.9	820.9	820.9
Supplies	12.8	36.5	52.5	52.6	52.6	52.6
Equipment	180.0	187.5	120.0			
Land & Structures						
Grants & Claims						
Miscellaneous						
TOTAL OPERATING	1,159.7	2,605.0	3,568.4	3,455.5	3,455.5	3,455.5

CAPITAL EXPENDITURES**	1,942.0	2,217.0	1,226.0			
-------------------------------	----------------	----------------	----------------	--	--	--

CHANGE IN REVENUES ()	175,000.0	350,000.0	350,000.0	350,000.0	350,000.0	350,000.0
-------------------------------	------------------	------------------	------------------	------------------	------------------	------------------

FUND SOURCE (Thousands of Dollars)

1002 Federal Receipts						
1003 GF Match						
1004 GF	3,098.7	4,822.0	4,794.4	3,455.5	3,455.5	3,455.5
1005 GF/Program Receipts						
1037 GF/Mental Health						
Other (Specify Type)						
TOTAL	3,098.7	4,822.0	4,794.4	3,455.5	3,455.5	3,455.5

Estimate of current year (FY99) cost: 0.0

POSITIONS

Full-time	24	1	16			
Part-time						
Temporary		46	46	46	46	46

ANALYSIS: (See attached for further analysis)

** These estimates do not include a contingency allowance (see narrative).

Prepared by Brett Fried Phone 465-3682
 Division Income and Excise Audit Date/Time February 8, 1999
 Approved by Wilson L. Condon Date February 8, 1999
 Commissioner Wilson L. Condon
 Agency Department of Revenue

PREPARER TO PROVIDE ALL DISTRIBUTION COPIES TO GOVERNOR'S LEGISLATIVE OFFICE
 For further distribution information, call the Governor's Legislative Office

Alaska Credit Individual Income Tax
Draft 1-GB1057.A
February 8, 1999
Page 2 of 14

BILL ANALYSIS

The bill is designed to implement a state income tax on individuals, trusts, and estates, using a simplified format keyed to the income tax liability reported on the federal income tax return. A family unit, such as parents and children, will file one return combining all tax that may be shown on any federal returns filed by the children. The tax is imposed at the rate of 31% of the federal tax. The federal tax is the tax after federal credits but before other taxes (currently line 49 on the 1998 1040 form) such as the alternative minimum tax.

A tax credit of 33% of the permanent fund dividend is allowed for each family member claimed as a dependent who receives a dividend in the tax year. The design is to make the benefit of the tax credit go as far as possible within the family unit. In addition, a 10.2% tax credit is allowed on the amount of longevity bonus payments received in the tax year. This effectively removes the bonus payments from the federal tax and, correspondingly, the Alaska tax. The 10.2% is determined by multiplying a 31% state tax rate by an assumed 33% effective federal tax rate. Unlike the PFD credit, the longevity bonus credit is not designed to hold the recipient harmless from the effect of the federal income tax.

A 10.2% credit is also allowed for the amount of interest received on obligations of the United States. This credit only applies if the state is precluded by federal law from applying a state tax based upon a percentage of the federal tax, a portion of which is attributable to this type of interest.

Residents will compute the Alaska tax based upon 100% of the federal tax. However, residents are allowed a credit for taxes paid to other states. Nonresidents are taxed on the percentage of the total tax attributable to Alaska income. The methodology used to compute the Alaska tax for nonresidents is the percentage of the total tax that Alaska income bears to total income.

Withholding is required on wage income. Withholding is also required in the typical crew share arrangement in the fishing industry.

A tax on individuals requires that trusts and estates also be subject to the income tax. This is necessary for fairness and to avoid creating a potentially large tax loophole. The scheme for taxation of these entities essentially follows that for resident and nonresident individuals. An Alaska trust and estate is taxed by reference to the federal tax, with a credit allowed for taxes paid to other states, and all other trusts and estates are taxed only on a percentage of the total tax attributable to Alaska income. On balance, the tax scheme is inherently simple. A taxpayer can easily determine the tax without having to pay a

Alaska Credit Individual Income Tax
Draft 1-GB1057.A
February 8, 1999
Page 3 of 14

CPA or attorney to prepare the return. This simplicity also means that it will be easier and less costly for the state to administer than other tax schemes.

A section by section analysis of the bill follows:

SECTION 1 – FINDINGS AND PURPOSE

This section states the income tax is intended to be a revenue raising measure.

SECTION 2 – TAXPAYER REQUIREMENTS IN CONSTITUTIONAL DISPUTES

This section adds a new subsection to the taxpayer appeals provision. The bill provides that a taxpayer that intends to contest a tax on constitutional or preemption grounds must file a notice of protest with the return and pay the amount of the contested tax. A failure to file the notice with the return precludes a refund if the tax is subsequently determined to be unconstitutional. The notice begins the informal conference administrative appeal process but this procedure is terminated if the taxpayer subsequently files an action in superior court as provided by law. The provision is intended to provide early notice of, and expedited action on, constitutional claims, and to reduce the state exposure to refund claims.

SECTIONS 3 and 4 – REFUND CLAIMS IN CONSTITUTIONAL DISPUTES

In conformity with Section 1 that requires a notice of protest with the return as a refund condition, these sections amend the statutory refund provision to remove constitutional and preemption claims from the standard two and three year filing period. The notice of protest filed with the return is considered to be a timely refund claim. The sections further provide that a taxpayer may file an action with the superior court within 60 days of the notice of protest and avoid the administrative appeal process in an appropriate case.

SECTION 5 – IMPOSITION OF TAX

This section imposes the income tax on resident individuals, nonresident and part-year resident individuals, and estates and trusts with income from sources in the state. The tax rate is 31% of the federal income tax after federal credits and before other federal taxes.

Nonresident and part-year resident individuals first compute the tax as a resident would do by applying the 31% tax rate to the entire federal tax liability. The Alaska tax liability is then determined by multiplying that result by the percentage that Alaska source income bears to all income.

Alaska Credit Individual Income Tax
Draft 1-GB1057.A
February 8, 1997
Page 4 of 14

SECTION 6 – RETURNS REQUIRED

This section amends the current law that applies only to corporations to provide that individuals, trusts, estates, and partnerships are also required to file income tax returns within 30 days after the federal return is required to be filed. Partnership returns will be in the nature of information returns.

SECTION 7 – AMENDED RETURNS REQUIRED FOR IRS ADJUSTMENTS

This section provides that the department may require a copy of the federal return be filed with the state return. The department currently does not intend to require the filing of a copy of the federal return with resident individual returns.

This section also amends current law to provide an objective bright line rule for how to comply at the state level with adjustments to the federal income tax returns. An amended state return is required to be filed within 60 days after a federal amended return is filed, the date upon which a federal assessment is made, or the date upon which the taxpayer waives the restrictions on assessment. This is a generally a codification of a long-standing department interpretation of present law.

SECTION 8 – CONSOLIDATED RETURNS BY FAMILY UNITS

This section provides that a family unit shall file one consolidated income tax return. The family unit is defined as all resident individuals for whom a personal exemption is claimed. For example, parents may file a joint federal return and their children may file separate federal returns. For Alaska tax purposes the federal tax shown on those filings would be combined on one state return for purposes of determining the Alaska tax.

The consolidated return requirement is achieved by aggregating all the federal tax shown on all federal returns filed by individuals in the family unit. All available state credits are then aggregated as well and applied against the state tax.

SECTION 9 – DEDUCTION FOR TAXES BASED ON NET INCOME

This section is a housekeeping amendment to make clear that only corporations are not allowed to deduct any taxes based on or measured by net income. Under the simplified individual, trust and estate income tax scheme provided in the bill, taxes of this nature are characteristically deducted in arriving at the federal tax liability. This is not envisioned to be a specific modification requiring a recomputation of the federal tax pursuant to the bill.

SECTION 10 – INCOME FROM SOURCES IN THE STATE DEFINED

For purposes of better clarity, this section repeals and reenacts the provision that allocates by source the income of individuals, estates, and trusts. In addition, the section provides that all the income of a trust established under Alaska law and of an estate of an Alaska

Alaska Credit Individual Income Tax
Draft 1-GB1057.A
February 8, 1999
Page 5 of 14

decedent is from an Alaska source. Income from other trusts and estates is considered to be from an Alaska source only to the extent it arises from a taxable or business situs in Alaska. The income distributed from an Alaska trust to a beneficiary for which the trust receives an income distribution deduction is considered to be Alaska source income to the beneficiary.

SECTION 11 – STATE CREDITS ALLOWED AGAINST THE TAX

This section contains the entire universe of state specific credits that are available to individuals, estates, and trusts under the income tax scheme. Except for the federal credits incorporated into state law by basing the Alaska tax on the federal tax liability after credits, no other state specific credits outside AS 43.20.046 are allowed and the credits are limited to the amount of tax liability for the taxable year in which the credits are generated with no carryback or carryforward to any other tax year.

A resident, and a trust established under state law and an estate of an Alaska decedent, is allowed a credit on taxes paid to another state or territory on income derived in that other jurisdiction. Since the tax on these persons is based on all their income, the credit prevents income from being taxed twice. The credit amount is the percentage of the computed Alaska tax that the income derived in the other jurisdiction bears to all income, and it may not exceed the actual tax paid to the other state or territory.

A credit of 33% of the amount of a permanent fund dividend is allowed for each exemption claimed on the federal return. The 33% credit amount is a rough approximation of the federal tax payable to the IRS on the dividend and the additional state tax resulting from piggybacking the state tax upon the federal tax. Each person for whom the exemption is claimed must receive the dividend in that tax year in order for the credit to apply to that exemption. This provision matches the credit with the family unit. For example, a dependent may file a separate federal return. However, the exemption for this individual is taken on the federal return of the person who supports the dependent rather than on the dependent's return. The credit provided in this section is taken on the consolidated return of the family unit. This allows for ease of administration and also provides a greater benefit to the family unit since the dependent likely is not in a 33% federal tax bracket.

10.2% of the amount of longevity bonus payments are allowed as a credit against the Alaska tax. The purpose of this credit is to remove from the federal tax the portion attributable to the inclusion of longevity bonus payments. A 33% federal marginal tax rate is used for this purpose. Multiplying the amount of the longevity bonus payments received by 33% equals the federal tax and then multiplying that amount by the Alaska tax rate of 31% is the amount of the Alaska tax that would otherwise be imposed on the

Alaska Credit Individual Income Tax
Draft 1-GB1057.A
February 8, 1999
Page 6 of 14

longevity bonus payments. The 10.2% credit is thus the result of multiplying 33% by 31%.

A similar credit is provided for the amount of interest received on obligations of the United States, but only to the extent required by federal law. Federal law precludes a state from taxing this income but it is unclear whether that prohibition applies to a situation where the Alaska tax is based upon a percentage of the federal tax. This credit will be unavailable if Alaska is not required by federal law to provide a credit of this nature.

SECTION 12 - ADMINISTRATION

This section is a housekeeping amendment to delete archaic and outdated provisions.

SECTION 13 - WITHHOLDING OF TAX ON WAGES

This section requires that employers withhold the state income tax from wages paid to employees at a rate of withholding set by the department, and then to report and remit the tax. For purposes of withholding, a person who pays compensation to another in the form of a share of the income from a commercial fishing activity must withhold the state income tax from the payment. These "crew share" arrangements are generally not subject to federal withholding but are necessary at the state level because many of the recipients are nonresidents. Withholding avoids some of the problems that otherwise would arise in trying to collect the tax from persons outside the state.

SECTION 14 - HOUSEKEEPING

This section merely makes a housekeeping amendment consistent with the amended return requirement provided in SECTION 7 of the bill.

SECTION 15 - DEFINITIONS

This section defines the terms "domicile", "individual", "nonresident", and "resident". For tax purposes, a resident is not defined as a resident under the Alaska permanent fund dividend program. An individual may be a resident for income tax purposes and not qualify for a permanent fund dividend.

SECTION 16 - SECTIONS REPEALED

This section repeals AS 43.20.012, which excludes individuals, trusts, and estates from income tax, AS 43.20.013, which is a suspended refundable credit provision, AS 43.20.200(a), which deals with the review of returns that is covered in AS 43.05, and AS 43.20.300, which has been outdated since 1975 when provisions of the Internal Revenue Code were incorporated through AS 43.20.021.

#1

Alaska Credit Individual Income Tax
Draft 1-GB1057.A
February 8, 1999
Page 7 of 14

SECTION 17 - REGULATION TRANSITION

This section allows the department to adopt regulations in 1999 to take effect on or after the bill effective date.

SECTION 18 - PROVISIONS ARE SEVERABLE

This section provides that a provision held invalid is severable from the remaining unaffected provisions.

SECTION 19 - IMMEDIATE EFFECTIVE DATE FOR REGULATIONS

Provides that *SECTION 17*, which allows the department to adopt regulations in 1999, has an immediate effective date.

SECTION 20 - BILL EFFECTIVE DATE

Establishes a January 1, 2000 effective date for the income tax on individuals, estates,

OPERATING EXPENDITURES

A separate unit of the Income and Excise Audit Division will be created to administer the taxation of income of individuals, estates, and trusts.

In general, the unit would be responsible for educating taxpayers about the tax, and receiving and processing tax returns and payments. The current Income and Excise Audit Division processes approximately 30,000 returns and reports for 16 programs. These programs are small in comparison to the processing of the 370,000 tax returns and 64,000 employer quarterly reports expected each year under the new tax bill. The new unit would be more specialized with respect to high volume processing and enforcement. There are two systems necessary to implement the taxation of individuals, estates, and trusts:

- ✓ individual, estate, and trust system
- ✓ employer withholding system

Staffing

The Individual Income Tax unit would include the following sections:

- Taxpayer Service
- Data Entry
- Accounting & Cash Management
- Compliance
- Appeals
- Programming

Alaska Credit Individual Income Tax
Draft I-GB1057.A
February 8, 1999
Page 8 of 14

We would staff the unit with 41 permanent positions and 46 temporary positions. We would utilize the temporary positions for data entry, mail handling, and taxpayer service. Temporary personnel would work five months a year in data entry, or three months in mail handling and taxpayer service. We have planned two shifts a day to maximize client (taxpayer) service and to minimize equipment costs.

We calculated the staffing costs included in this fiscal note by patterning the new unit after the existing structure of the Income and Excise Audit Division with the addition of a Taxpayer Service Section and the augmentation of the Collection Section. We adjusted staffing for differences in the number of documents processed. We planned staffing utilizing the lowest staff grades possible.

We have checked the proposed staffing level for reasonableness by comparison to the states of Montana and North Dakota. We selected these states for comparability in population base and complexity of the income tax. We compared staffing requirements to the Permanent Fund Dividend Division for reasonableness and for the contingency that we would combine mail room and data entry operations to gain economies of scale.

We have planned staffing based on the first dates that particular staff is needed. For example, collection staffing would not be funded until FY 02, audit staffing funded in FY 01. One appeals position would be funded in FY 00 to draft regulations, policies, and procedures. The second appeals position would be funded in FY 02, as appealed cases increase.

CAPITAL EXPENDITURES

Start-up costs are difficult to quantify because the last state to build a new system was Connecticut in 1991. At the time, the best available technology was main-frame technology; their start-up costs were \$7.6 million in the first year of implementation of the tax. We would not choose a main-frame system because of its lack of flexibility. Most states are moving toward client-server technology. Wyoming has more recently studied (but not ultimately imposed) a personal income tax. Their start-up costs were estimated at \$3.8 million, based on a client-server environment. This included imaging equipment (to store the document), but did not include Optical Character Recognition software, which would take the place of data-entry. These estimates were rough and were not detailed.

We estimate that the costs will be approximately \$5.4 million spread out over the first three years of implementation. The Administrative Services Division based this estimate on the list of tasks to be performed by the system (see attached task list). Because we had such a short time frame to analyze costs and a true needs analysis was not performed,

#1

Alaska Credit Individual Income Tax
Draft 1-GB1057.A
February 8, 1999
Page 9 of 14

most experts would recommend a contingency allowance of 100-300 percent. These estimates do not include such a contingency allowance recognizing that budgets are reviewed and can be corrected on an annual basis. The estimated cost is significantly affected by the short time-frame for implementation. Projects of this magnitude, of such a critical nature, normally are designed, implemented, tested, and brought on-line in 18 months.

REVENUE

The attached analysis details the revenue increase due to the imposition of the Alaska Credit Individual Income tax. We used 1996 Internal Revenue Service data, plus the federal tax based upon a 10% increase in Alaska Gross Income to account for non-residents. In FY 00, we are estimating that the Alaska Credit Income Tax will result in 175 million dollars of revenue. This is half of the total annual revenue estimate of 350 million dollars. Actual revenue might be larger or smaller depending on the timing of withholding, refunds and estimated payments. For FY 01-05, we are estimating an annual revenue of 350 million dollars. Clearly, this does not account for inflation, growth of real income, population increases or labor market effects. We did not include any of these factors to try and minimize the amount of uncertainty in our revenue model. Additionally, any labor-supply effects will probably be counter balanced by income and population growth. Economists differ on the size of labor-supply effects but in a survey of the literature done by Heckman (1993), he found that elasticities are closer to zero than one. That is, the labor supply is not very responsive to changes in wages and income.

System Tasks

The computer hardware and software (the system) are necessary to process income tax returns, employer reports, and payments. We will use the system for the following tasks:

- credit withholding payments to employer payors and individual taxpayer accounts
- record employer quarterly reports including individual taxpayers to which the reports relate (names social security numbers, and amounts for each taxpayer.)
- credit estimated tax payments and payments received with individual income tax returns
- record individual income tax return information
- cross-match employer withholding to withholding claimed by individual taxpayers
- cross-match income tax filings with Internal Revenue Service data tapes to check validity of tax returns filed and to identify non-filers
- link to Permanent Fund Division data to establish taxpayer name, address, and social security data-base and to identify income tax non-filers who did not file a federal income tax return
- cross-match employer quarterly report filings with Department of Labor to identify non-filers
- record and cross-match Form 1099-equivalent to identify non-filers
- generate routine billings for tax, interest, and penalties due
- generate subsequent demand letters in the event of non-payment
- generate liens and levies upon determination by enforcement personnel
- link to Permanent Fund Division data for validity check on deductions or credits with respect to the Permanent Fund Dividend.
- provide access to taxpayers for electronic filing

Alaska Credit Individual Income Tax

Draft 1-GB1057.A

February 8, 1999

Page 11 of 14

- link to Child Support Enforcement Division for seizure of income tax refunds for application to delinquent child support obligations

- link to Permanent Fund Dividend Division and possibly Child Support Division data to provide an opportunity for taxpayers to choose to apply available money toward their income tax

Alaska Administration Costs Using Estimated Stalling Requirements (in thousands)

By Fiscal Year

Stalling	# Positions	Range	start date	annual costs excluding payroll**	Personal Services	Total annual costs	PERSONNEL DEPENDENT COSTS								
							FY 00		FY 01	FY 02	FY 03	FY 04	FY 05		
							equipment	operating							
Permanent Full Time															
Deputy Director adm	1		24 Jul-99	20.0	86.9	115.7	7.5	115.7	115.7	115.7	115.7	115.7	115.7	115.7	115.7
Appeals-RA IV appeals	1		20 Aug-99	17.6	67.7	85.3	7.5	78.2	85.3	85.3	85.3	85.3	85.3	85.3	85.3
Appeals-RA IV appeals	1		20 Aug-01	17.5	67.7	85.2	7.5		78.1	85.2	85.2	85.2	85.2	85.2	85.2
RAS I operations	1		22 Aug-99	17.6	76.6	94.2	7.5	86.4	94.2	94.2	94.2	94.2	94.2	94.2	94.2
RAS I exam	1		22 Jul-01	17.5	76.6	94.1	7.5		94.1	94.1	94.1	94.1	94.1	94.1	94.1
RA III exam	2		18 Jul-01	43.6	118.6	162.2	15.0		162.2	162.2	162.2	162.2	162.2	162.2	162.2
TE II exam	2		12 Apr-00	27.6	82.4	110.0	15.0	27.5	110.0	110.0	110.0	110.0	110.0	110.0	110.0
TE II exam	2		12 Jul-01	27.6	82.4	110.0	15.0		110.0	110.0	110.0	110.0	110.0	110.0	110.0
Ad Clk II exam	1		8 Apr-00	13.8	33.7	47.5	7.5	11.9	47.5	47.5	47.5	47.5	47.5	47.5	47.5
REO III collection/rets	1		18 Jul-00	10.8	59.3	78.1	7.5		78.1	78.1	78.1	78.1	78.1	78.1	78.1
REO II collection/rets	1		16 Jul-01	18.3	52.0	71.1	7.5		71.1	71.1	71.1	71.1	71.1	71.1	71.1
TCS II collection/rets	1		12 Jul-01	13.8	41.2	55.0	7.5		55.0	55.0	55.0	55.0	55.0	55.0	55.0
Ad Clk II collection/rets	1		8 Jul-01	13.8	33.7	47.5	7.5		47.5	47.5	47.5	47.5	47.5	47.5	47.5
TCS II collection/\$	2		12 Jul-01	27.6	82.4	110.0	15.0		110.0	110.0	110.0	110.0	110.0	110.0	110.0
REO III collection/\$	1		18 Jul-01	18.8	59.3	78.1	7.5		78.1	78.1	78.1	78.1	78.1	78.1	78.1
REO I collection/\$	1		14 Jul-01	13.8	45.3	59.1	7.5		59.1	59.1	59.1	59.1	59.1	59.1	59.1
Accl. Tech II collection/\$	2		14 Jul-01	27.6	90.6	118.2	15.0		118.2	118.2	118.2	118.2	118.2	118.2	118.2
Ad Clk II collection/\$	1		8 Jul-01	13.8	33.7	47.5	7.5		47.5	47.5	47.5	47.5	47.5	47.5	47.5
AP V programming	1		22 Sep-99	18.8	76.6	95.4	7.5	79.5	95.4	95.4	95.4	95.4	95.4	95.4	95.4
AP IV programming	1		20 Sep-99	18.8	67.7	86.5	7.5	72.1	86.5	86.5	86.5	86.5	86.5	86.5	86.5
AP II programming	1		16 Sep-99	18.8	52.8	71.6	7.5	59.7	71.6	71.6	71.6	71.6	71.6	71.6	71.6
TE II lps	1		12 Sep-99	13.8	41.2	55.0	7.5	45.8	55.0	55.0	55.0	55.0	55.0	55.0	55.0
TE II lps	2		12 Jan-00	27.6	82.4	110.0	15.0	55.0	110.0	110.0	110.0	110.0	110.0	110.0	110.0
Accl. Sup. II acc/\$ mgt	1		16 Mar-00	13.8	52.8	66.6	7.5	22.2	66.6	66.6	66.6	66.6	66.6	66.6	66.6
Accl. Tech II acc/\$ mgt	1		14 Mar-00	13.8	45.3	59.1	7.5	19.7	59.1	59.1	59.1	59.1	59.1	59.1	59.1
Accl. Tech I acc/\$ mgt	1		12 Mar-00	13.8	41.2	55.0	7.5	18.3	55.0	55.0	55.0	55.0	55.0	55.0	55.0
Ad Clk II acc/\$ mgt	1		8 Mar-00	13.8	33.7	47.5	7.5	15.8	47.5	47.5	47.5	47.5	47.5	47.5	47.5
Ad Clk I acc/\$ mgt	1		7 Mar-00	13.8	32.4	46.2	7.5	15.4	46.2	46.2	46.2	46.2	46.2	46.2	46.2
Accl. Tech II data entry	1		14 Apr-00	13.8	45.3	59.1	7.5	14.8	59.1	59.1	59.1	59.1	59.1	59.1	59.1
Ad Clk II data entry	4		8 Apr-00	55.2	134.8	190.0	30.0	47.5	190.0	190.0	190.0	190.0	190.0	190.0	190.0
Ad Mgr. adm	1		15 Jul-99	13.8	49.3	63.1	7.5	63.1	63.1	63.1	63.1	63.1	63.1	63.1	63.1
Ad Clk II adm	1		8 Aug-99	13.8	33.7	47.5	7.5	43.5	47.5	47.5	47.5	47.5	47.5	47.5	47.5
Subtotal permanent positions	41			611.3	1980.1	2621.4	307.5	892.1	1,583.4	2,614.3	2,621.4	2,621.4	2,621.4	2,621.4	2,621.4
Temporary															
Ad Clk II (mail/files (acctng))	4	8	2/20-5/19	15.1	33.6	48.7	15.0		48.7	48.7	48.7	48.7	48.7	48.7	48.7
TE II lps	17	8	2/20-5/19	64.9	142.8	207.7	67.5		207.7	207.7	207.7	207.7	207.7	207.7	207.7
Ad Clk II data entry	25	8	2/01-6/30	143.1	350.0	493.1	97.5		493.1	493.1	493.1	493.1	493.1	493.1	493.1
	46			223.1	526.4	749.5	180.0		749.5	749.5	749.5	749.5	749.5	749.5	749.5
Equipment															
								180.0	187.5	120.0					
SUBTOTAL--PERSONNEL-DEPENDENT COSTS															
	87			864.4	2,506.5	3,370.9	487.5	1,072.1	2,520.4	3,483.8	3,370.9	3,370.9	3,370.9	3,370.9	3,370.9
Add: Common area occupancy*															
				84.6		84.6		84.6	84.6	84.6	84.6	84.6	84.6	84.6	84.6
TOTAL COSTS															
				949.0	2,506.5	3,455.5	407.5	1,156.7	2,605.0	3,568.4	3,455.5	3,455.5	3,455.5	3,455.5	3,455.5

0% Personnel annual step increase assumed
 Implementation Team

* Common area includes: taxpayer lobby, mailroom, conference rooms, life space

** Includes travel, contractals, supplies, and space costs. Contractals include maintenance, copier lease, data-base access charges, outside services, etc.

12-14
 SR 17

1#

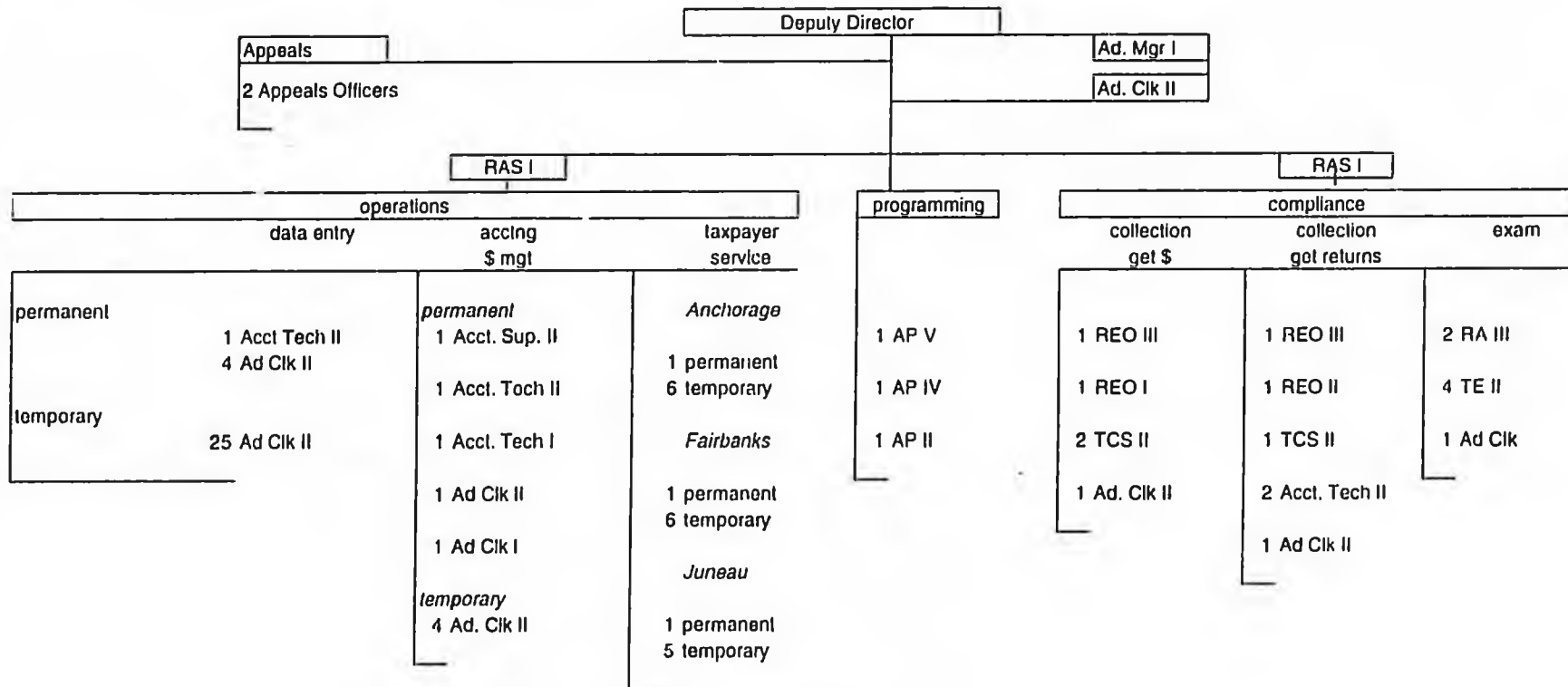

total FTE's		
permanent		41.0
temporary	21 * 3 mo. =	5.3
temporary	25 * 5 mo. =	10.4
total FTE's		<u>56.7</u> *

REO = Revenue Enforcement Officer (old class)
 ranges equal to Revenue Auditor class

TCS = Tax Collection Specialist (old class)
 ranges equal to Tax Examiner class

SB 67
13-14

	A	B	C	D	E	F	G
1	Alaska Credit Individual Income Tax						
2	Draft 1-GB1057.A						
3	February 8, 1999						
4	Page 14 of 14						
5							
6	1996 SOI Data		% of Federal Income Tax				
7							
8							
9	Target Revenue	\$ 350,000,000					
10	NR Business Income Tax Est.	\$ -	<<<Enter the revenue you expect from Non-resident business income				
11	Model Target Revenue	\$ 350,000,000					
12	Rate on Fed Tax < \$4,000	none	<<< none = flat				
13	PFD (individual amount)	\$ 1,500					
14	PFD Credit (Y or N)	y	>>>> If 'Y' enter >>>>>		% PFD for credit	33.3%	
16							
17	AGI range (000)	< \$30	\$30 < 50	\$50 < 75	\$75 < 100	>= \$100	Total
26							
27	Federal income tax	136,794,000	229,625,000	330,627,000	273,064,000	680,937,000	1,651,047,000
28	Est FIT on NR wages	21,821,820	25,063,995	30,207,345	20,641,650	25,906,425	123,641,235
29							
30	Alaska Tax Base	158,615,820	254,688,995	360,834,345	293,705,650	706,843,425	1,774,688,235
31	Amount over Bracket			360,834,345	293,705,650	706,843,425	
32							
33	Tax Generated (Base x Rate)	49,048,331	78,756,773	111,579,805	90,821,785	218,575,235	548,781,929
34							
35	PFD Credit	(40,844,430)	(49,665,035)	(46,477,726)	(24,500,969)	(20,959,769)	(182,453,929)
36	Credit: taxes pd to other states	(1,456,000)	(3,132,000)	(4,763,000)	(3,324,000)	(3,653,000)	(16,328,000)
37							
38							
39	Revenue (Tax - Credits)	6,747,901	25,959,737	60,339,080	62,990,816	193,962,466	350,000,000
40							
41	Flat Rate	31%	31%	31%	31%	31%	

5B 67
14-14

#1

TONY KNOWLES
GOVERNOR



P O Box 110001
Juneau, Alaska 99811-0001
(907) 465-3500
Fax (907) 465-3532

STATE OF ALASKA
OFFICE OF THE GOVERNOR
JUNEAU

February 9, 1999

The Honorable Drue Pearce
Senate President
Alaska State Legislature
State Capitol
Juneau, AK 99801-1182

Dear President ^{Drue} Pearce:

As part of the Alaska Balanced Budget Plan I proposed to close Alaska's budget gap within the next 18 months, today I am transmitting a bill to re-impose a state income tax on individuals.

The current size of our fiscal gap—the difference between annual revenues and expenditures—exceeds one billion dollars. Because of our sizeable savings account, the Constitutional Budget Reserve (CBR), we have been able to fill this gap over the past several years. However, the CBR is currently projected to run dry in the next three years. Although we have cut the budget substantially over the past four years, and further cuts and efficiencies must take place, budget cuts alone will not solve a budget gap of this proportion if basic state services to Alaskans are to be preserved.

One part of the plan is to transfer \$4 billion dollars from the Earnings Reserve Account of the Permanent Fund to the CBR. This will generate approximately \$550 million annually. However, this too will not close the gap. I believe an income tax is the fairest way to provide the additional \$350 million dollars needed to balance our budget in the next 18 months.

Alaska's tremendous natural resource wealth has allowed us to maintain the basic services of state government for many years without significant contributions from the Alaskans who benefit from those services. We also have been able to return dividends from that wealth to Alaskans. But existing revenue sources simply will not sustain the basic services -- the schools, protection of our children, contributions to local communities, and other basic health and safety programs -- on which Alaskans rely.

The Honorable Drue Pearce

February 9, 1999

Page 2

A state individual income tax is one way to address at least a part of the budget gap. Alaska is the only state that has neither a state personal income tax nor a statewide sales tax. I believe an income tax is one of the fairest ways to raise revenue. It taxes people on their ability to pay and taxes people who work in Alaska, whether they live here or not. Non-residents can begin to contribute to the state-provided services they receive.

The tax set out in the attached bill begins with a simple percentage of the federal tax we pay. It then provides every Alaskan a credit, based on the Permanent Fund Dividend that person receives, as a way to compensate for the federal tax we pay on our dividends. This feature of the bill, because it provides a per-capita credit, protects families. Under the bill, a family of four earning \$60,000 would pay no tax.

I urge your prompt consideration of this bill. You may not agree that the structure of the proposed tax is the best, and I welcome your suggestions for alternatives. But we cannot afford to wait until all our reserves are expended. The Legislature must act this year to protect the future of all Alaskans.

Sincerely,

Tony Knowles
Governor

SENATE FINANCE COMMITTEE

SIGN-IN

SB 67-GOVERNOR'S INC TAX:INDIVID/EST/TRUSTS

NAME: WILLIAM CONDON Subject/Bill No: 67
Co./Dept./Title: Commissioner of Revenue Phone: 465-2301
Address: _____ Zip: _____
Do you wish to testify? Yes No Respond To Questions

NAME: _____ Subject/Bill No: _____
Co./Dept./Title: _____ Phone: _____
Address: _____ Zip: _____
Do you wish to testify? Yes No Respond To Questions

NAME: _____ Subject/Bill No: _____
Co./Dept./Title: _____ Phone: _____
Address: _____ Zip: _____
Do you wish to testify? Yes No Respond To Questions

NAME: _____ Subject/Bill No: _____
Co./Dept./Title: _____ Phone: _____
Address: _____ Zip: _____
Do you wish to testify? Yes No Respond To Questions

SENATE FINANCE COMMITTEE

SIGN-IN

SB 67-GOVERNOR'S INC TAX:INDIVID/EST/TRUSTS

NAME: Wilson Condon Subject/Bill No: SB67
Co./Dept./Title: Comptroller, DOR Phone: 2317
Address: _____ Zip: _____

Do you wish to testify? Yes No Respond To Questions

NAME: _____ Subject/Bill No: _____
Co./Dept./Title: _____ Phone: _____
Address: _____ Zip: _____

Do you wish to testify? Yes No Respond To Questions

NAME: _____ Subject/Bill No: _____
Co./Dept./Title: _____ Phone: _____
Address: _____ Zip: _____

Do you wish to testify? Yes No Respond To Questions

NAME: _____ Subject/Bill No: _____
Co./Dept./Title: _____ Phone: _____
Address: _____ Zip: _____

Do you wish to testify? Yes No Respond To Questions