

**HB**

**287**

# SENATE COMMITTEE REPORT

DATE: 5/6/95

FURTHER:

DATE TURNED INTO OFFICE: 5/8/95

Transportation Committee considered HOUSE BILL NO. 287

"An Act relating to outdoor advertising on trash receptacles and restrictions on outdoor advertising."

and recommends:

- be replaced with \_\_\_\_\_ CS \_\_\_\_\_
- adopt previous \_\_\_\_\_ CS \_\_\_\_\_
- attached amendment(s)
- adopt Letter of Intent by \_\_\_\_\_ Committee
- further referral to the \_\_\_\_\_ Committee

**Senate Bill:**

same title  
new title

**House Bill:**

same title  
technical change  
new: SCR \_\_\_\_\_

SIGNING/DO PASS	DP	OTHER RECOMMENDATIONS	NR	DNP	AM
<i>Lynne Green</i>	✓	<i>Adrian L. Taylor</i> <del>_____</del>	✓		
<b>CHAIR:</b>		<i>Steve Kier</i>	✓		

**NEW FISCAL NOTE(S):**

Department                      Date      Zero      Fiscal

**PREVIOUS FISCAL NOTE(S):\***

Department                      Date      Zero      Fiscal

<i>DUIPF - 016-48</i> <i>Commissioner</i>	<i>4/1/95</i>	✓	

APPROPRIATION -- no fiscal note

\*Include fiscal notes accompanying Governor's bill

# FISCAL NOTE

STATE OF ALASKA  
1995 LEGISLATIVE SESSION

BILL NO. HB 287

Revision Date: _____	Dept. Affected: <u>Transportation and Public Facilities</u>
Title: <u>An Act relating to outdoor advertising on trash receptacles and restrictions on outdoor advertising</u>	BRU: <u>Office of the Commissioner</u>
Sponsor: <u>Representative Rokberg</u>	Component: <u>Commissioner's Office</u>
Requester: <u>Representative Rokberg</u>	COMPONENT SERIAL NO. <u>530</u>

**Expenditures/Revenues** (Thousands of Dollars)

OPERATING EXPENDITURES	FY 96	FY 97	FY 98	FY 99	FY 00	FY 01
PERSONAL SERVICES	0.0	0.0	0.0	0.0	0.0	0.0
TRAVEL						
CONTRACTUAL						
SUPPLIES						
EQUIPMENT						
LAND & STRUCTURES						
GRANTS, CLAIMS						
MISCELLANEOUS						
<b>TOTAL OPERATING</b>	<b>0.0</b>	<b>0.0</b>	<b>0.0</b>	<b>0.0</b>	<b>0.0</b>	<b>0.0</b>

CAPITAL EXPENDITURES						
----------------------	--	--	--	--	--	--

CHANGE IN REVENUES						
--------------------	--	--	--	--	--	--

**FUND SOURCE** (Thousands of Dollars)

FUND SOURCE	FY 96	FY 97	FY 98	FY 99	FY 00	FY 01
1002 Federal Receipts						
1003 GF Match						
1004 GF	0.0	0.0	0.0	0.0	0.0	0.0
1005 GF/Program Receipts						
1006 GF/MHTIA						
Other						
<b>TOTAL</b>	<b>0.0</b>	<b>0.0</b>	<b>0.0</b>	<b>0.0</b>	<b>0.0</b>	<b>0.0</b>

Estimate of any current year (FY95) cost: \$ 0.0

**POSITIONS**

FULL-TIME						
PART-TIME						
TEMPORARY						

**ANALYSIS:** (Attach a separate page if necessary)

This bill would not affect the Department. As written, it would only apply to trash receptacles adjacent to bus shelters or bus benches. No fiscal impact would be expected.

Prepared by: <u>Sam Kito III, P.E.</u>	Phone: <u>465-3804</u>
Division: <u>Commissioner's Office</u>	Date: <u>3/29/95</u>
Approved by Commissioner:	Date: <u>3/30/95</u>
Agency: <u>Department of Transportation and Public Facilities</u>	

**PREPARER TO PROVIDE ALL DISTRIBUTION COPIES TO GOVERNOR'S LEGISLATIVE OFFICE**

For further distribution information, call the Governor's Legislative Office

# ALASKA STATE LEGISLATURE

## House of Representatives

### COMMITTEE ASSIGNMENTS

W. S. JOHNSON  
LAWRENCE S. TUCKER, JR., VICE CHAIR  
ADMINISTRATIVE REGULATION REVIEW, VICE CHAIR  
HEALTH, EDUCATION & SOCIAL SERVICES, MEMBER  
ELECTIONS, GOVERNMENT MEMBER



INTERIM  
710 WEST 8TH AVENUE, SUITE 200  
ANCHORAGE, AK 99501  
PHONE (907) 258-8121

SESSION  
STATE CAPITOL  
JUNEAU, AK 99801-1102  
PHONE (907) 485-4968  
FAX (907) 485-2040

### Representative Norman Rokeberg

#### SPONSOR STATEMENT

HB 287 - "An Act relating to outdoor advertising on trash receptacles and restrictions on outdoor advertising."

---

HB 287 was introduced to allow commercial advertising on the sides of trash receptacles that are located adjacent bus shelters and bus benches located on state highways.

Currently, the Municipality of Anchorage allows advertising on trash receptacles. A number of potential locations exist for additional litter containers but they are located on state maintained highways. HB 287 would remove the prohibition.

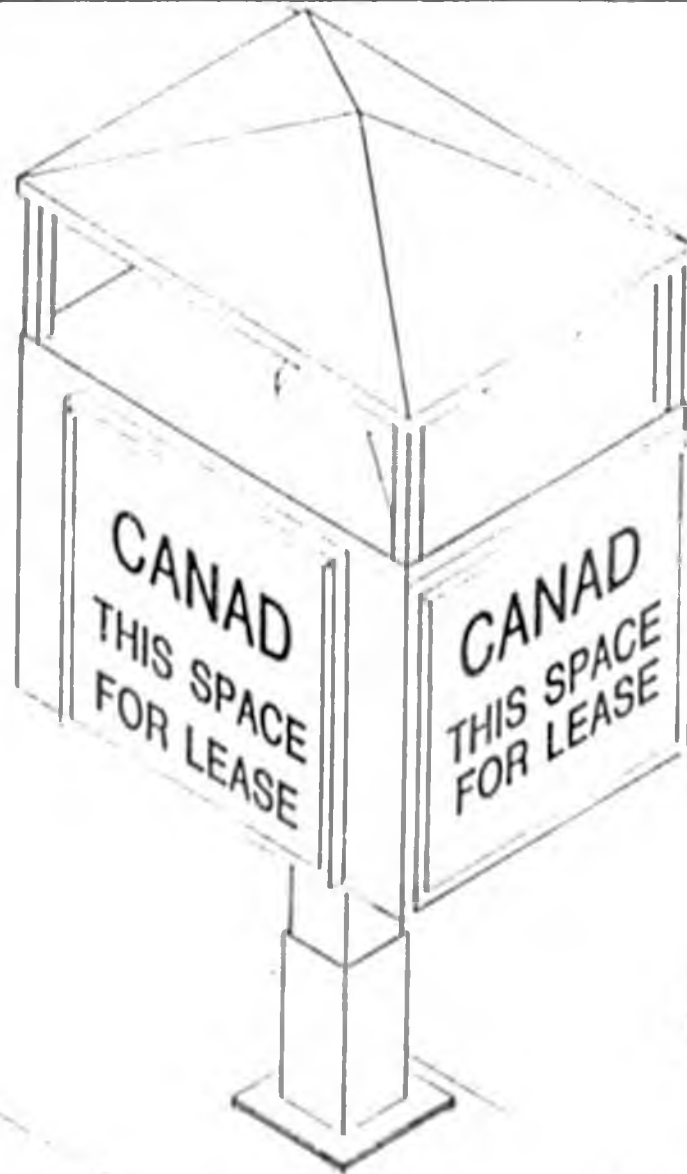

THIS MATERIAL MAY NOT BE REPRODUCED  
 IN WHOLE OR PART WITHOUT THE EXPRESS  
 WRITTEN PERMISSION OF CANAD PATENT  
 FENCING - COPYRIGHT 1993



**Design**  
 Drafting and Graphics

DATE	10/10/93
BY	10/10/93
SCALE	1:1
PROJECT	10/10/93
FILE NO.	10/10/93

ISOMETRIC  
 TRASH RECEPTACLE  
 FOR  
 CANAD

10/10/93  
 Eric C. Jones  
 PO Box 10771  
 MOBILE, ALABAMA 36688

NO.	DESCRIPTION	DATE



HOOD PLAN VIEW, PART 'E'

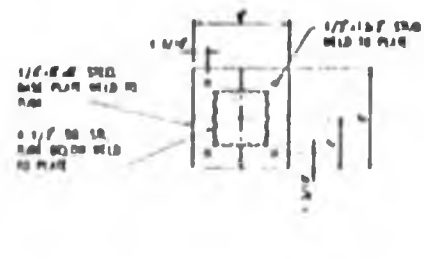

BASE & COLUMN PLAN VIEW, PART 'A'

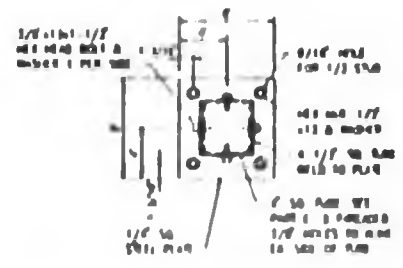

RECEPTACLE BASE-PLAN VIEW, PART 'B'

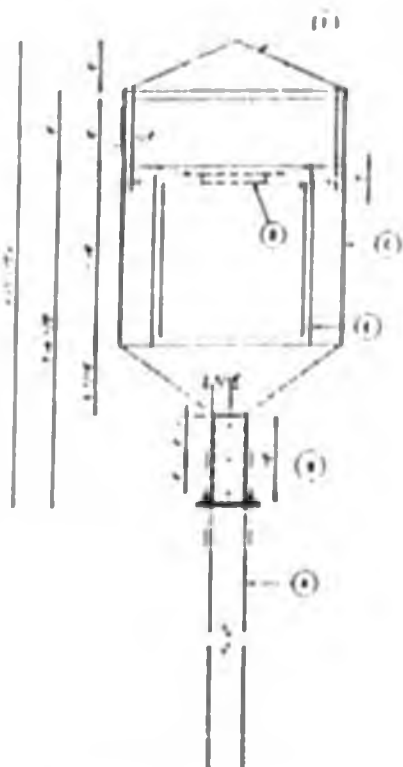

FRONT ELEVATION ASSEMBLY

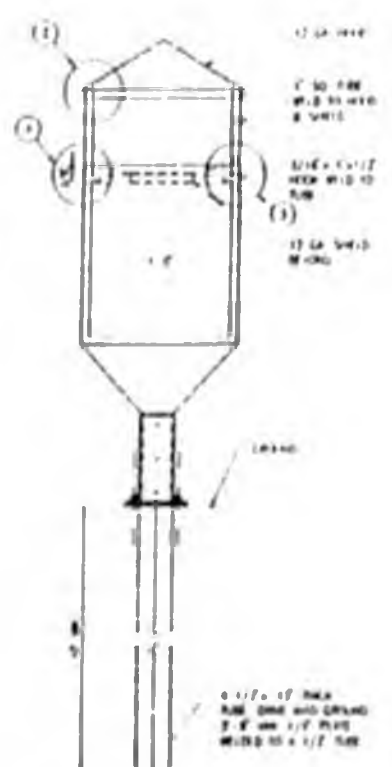

SIDE ELEVATION ASSEMBLY

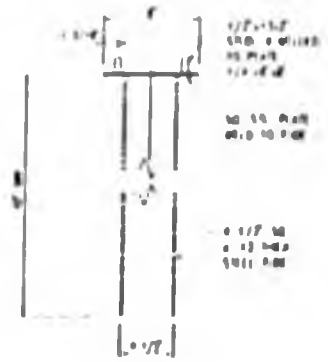

BASE & COLUMN ELEVATION PART 'A'

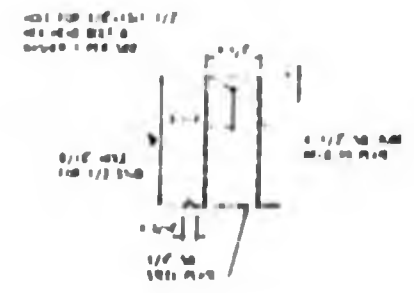

RECEPTACLE BASE-ELEVATION PART 'B'

- NOTES**
- ALL DIMS TO BE UNLESS OTHERWISE SPECIFIED
  - ALL DIMS TO BE CENTERLINE UNLESS OTHERWISE SPECIFIED
  - ALL DIMS TO BE TO CENTERLINE UNLESS OTHERWISE SPECIFIED
  - ALL DIMS TO BE TO CENTERLINE UNLESS OTHERWISE SPECIFIED
  - ALL DIMS TO BE TO CENTERLINE UNLESS OTHERWISE SPECIFIED

THIS MATERIAL MAY NOT BE REPRODUCED OR WHOLE OR PART WITHOUT THE EXPRESS WRITTEN PERMISSION OF CANAD PATENT PENDING - COPYRIGHT 1993



DATE	BY	CHKD

PLAN VIEW ELEVATIONS, & NOTES  
TRASH RECEPTACLE  
- CANAD

8400 C. Street  
P.O. Box 110721  
MEMPHIS, TENNESSEE 38111

NO.	REV.	DATE	BY	CHKD

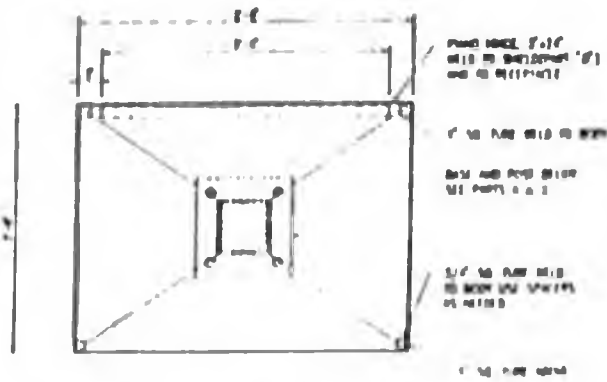

RECEPTACLE BODY-PLAN VIEW, PART C  
SCALE 1/2" = 1'-0"

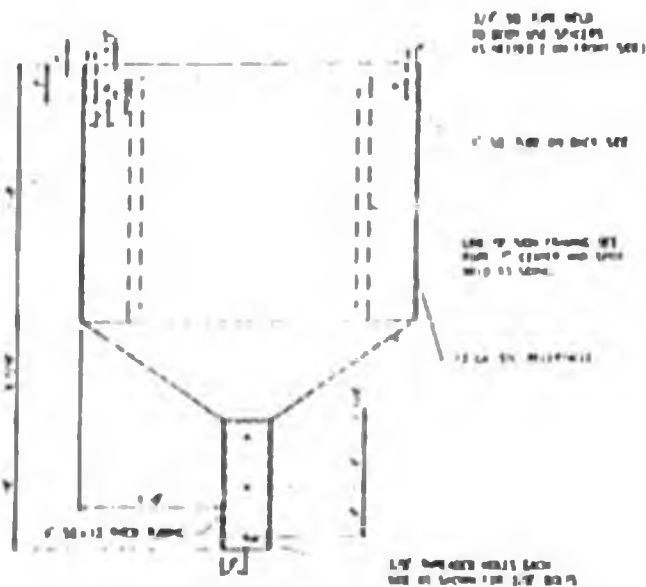

RECEPTACLE BODY-FRONT ELEV, PART C  
SCALE 1/2" = 1'-0"

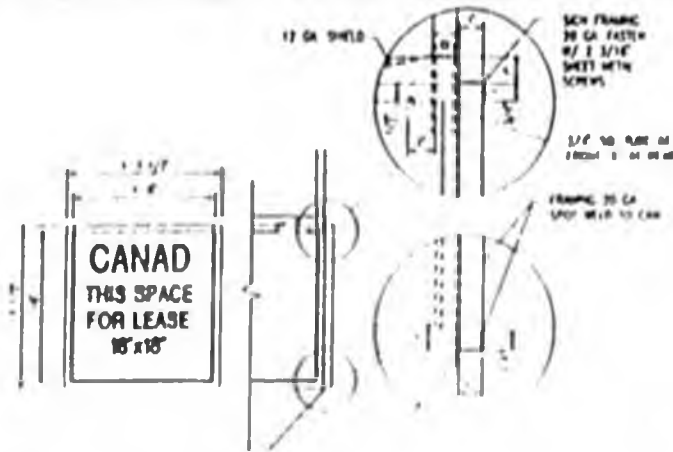

SIGN FRAMING, PART F  
SCALE 1/2" = 1'-0"  
PAGE 1 OF 1

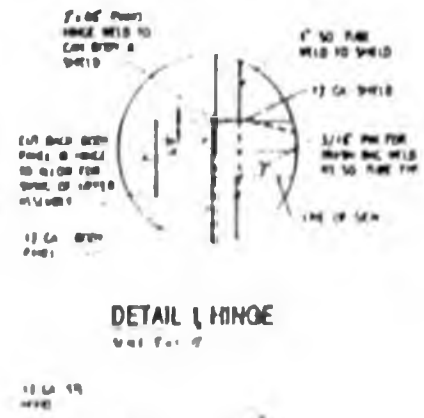

DETAIL 1, HINGE  
SCALE 1/2" = 1'-0"

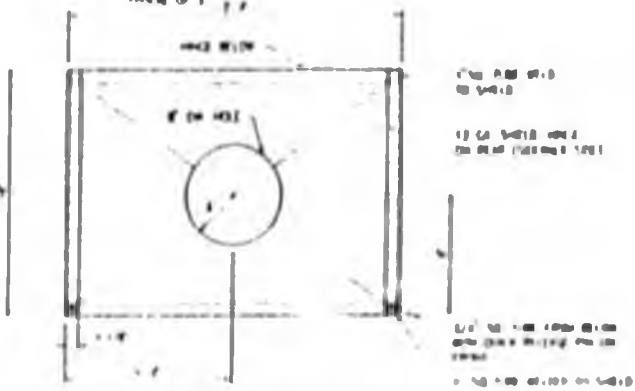

SHIELD PLAN VIEW, PART D  
SCALE 1/2" = 1'-0"

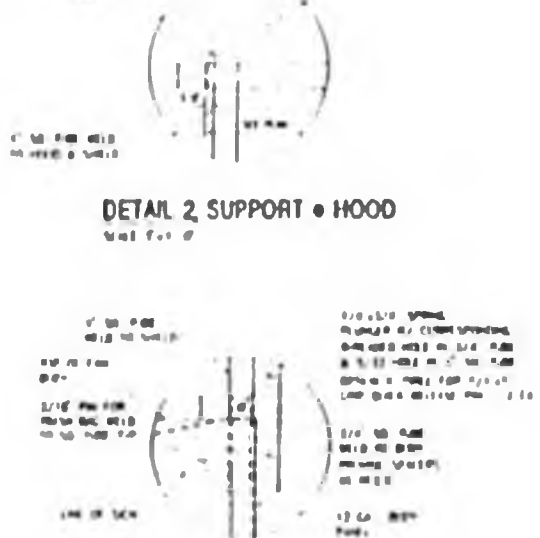

DETAIL 2, SUPPORT HOOD  
SCALE 1/2" = 1'-0"



SHIELD SIDE VIEW, PART D  
SCALE 1/2" = 1'-0"

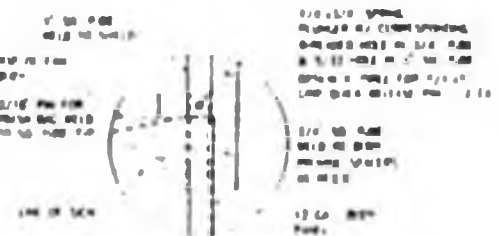

DETAIL 3, PIN SUPPORT  
SCALE 1/2" = 1'-0"

THIS MATERIAL MAY NOT BE REPRODUCED  
IN WHOLE OR PART WITHOUT THE EXPRESS  
WRITTEN PERMISSION OF CANAD PATENT  
PENDING - COPYRIGHT 1993



**Design**  
Drafting and Graphics

DATE	NO. OF SHEETS
BY	NO. OF SHEETS
CHECKED BY	NO. OF SHEETS
APPROVED BY	NO. OF SHEETS
DATE	NO. OF SHEETS

PLANS, ELEVATIONS, DETAILS  
TRASH RECEPTACLE  
by  
**CANAD**

PROJECT NO.  
Date: C. 1993  
P.O. Box 111721  
ANCHORAGE, ALASKA 99511

NO.	DESCRIPTION	DATE

# Alaska Statutes

## Title 19. Highways and Ferries.

### Chapter

- 05. Administration (§ 19 05 046)
- 25. Protection and Use of State Highways and Roads (§§ 19 25 010, 19 25 105, 19 25 123, 19 25 150, 19 25 200)
- 30. Access Roads (§§ 19 30 127, 19 30 233)
- 40. James Dalton Highway (§ 19 40 200)
- 45. Miscellaneous Provisions (§ 19 45 001)
- 60. Ferry Terminal Facilities (§ 19 60 030)
- 65. Alaska Marine Highway System (§§ 19 65 011, 19 65 025 — 19 65 100)

### Chapter 05. Administration.

#### Article

- 1. Department of Transportation and Public Facilities (§ 19 05 046)

#### Article 1. Department of Transportation and Public Facilities.

#### Section

- 46. [Repealed]

*Sec. 19 05 046. Accounting and disposition of receipts from non-state entities. [Repealed. § 25 ch 90 SLA 1991.]*

### Chapter 10. State Highway System.

#### Article 1. Designation, Marking, and Use.

#### Sec. 19.10.010. Dedication of land for public highways.

#### NOTES TO DECISIONS

**Rights of owners of subservient estates as to highways built on section line easements.** — A rule guaranteeing owners of subservient estates of section line easements a right of direct access to any highway which may be built on those easements would be inconsistent with the purpose of this statute, which is to provide easements on which it is relatively easy and inexpensive for the state to build highways. Compensation for loss

of direct access would have the opposite effect: it would greatly increase the cost of constructing controlled access highways on section line easements. 0 938 Acres v. State 142 P.2d 96; Alaska 1946; modified on other grounds 169 P.2d 99; Alaska 1949.

**Compensation owed when landowner deprived of reasonable access.** — When the state condemns the fee interest in land in which it owns a section line

ement, it owes no compensation for the loss of access to the easement, since no preexisting right was taken. Only if the taking deprives the landowner of reasonable access to the network of streets to which it previously had access would the state owe compensation. 096A Acres v. State, 762 P.2d 96 (Alaska 1988), modified on other grounds, 769 P.2d 990 (Alaska 1989).

The question whether a condemnee's remaining access to a condemned section line easement is reasonable is plainly a matter of degree. It involves an ad hoc analysis of the facts that actually or potentially lead to the property after the condemnation, to determine if they are suitable for the traffic that would likely go to the property. The analysis necessarily involves an examination of the potential use of the property. 096A Acres v. State, 762 P.2d 96 (Alaska 1988), modified

on other grounds, 769 P.2d 990 (Alaska 1989).

Nominal rather than actual damages are appropriate for condemnation of the fee underlying a highway right-of-way unless there is a showing of special value. 096B Acres v. State, 762 P.2d 96 (Alaska 1988), modified on other grounds, 769 P.2d 990 (Alaska 1989).

No duty to compensate for condemnee's increased burden of subdividing. — Even though section line easement condemnance may, as a result of the condemnation, have to dedicate more land for rights-of-way in subdividing their property than they would have in the absence of the condemnation, the state is not required to compensate them for that increased burden. 096A Acres v. State, 762 P.2d 96 (Alaska 1988), modified on other grounds, 769 P.2d 990 (Alaska 1989).

#### Sec. 19.10.085. Naming of a highway.

**Cross references.** For statutory provisions naming certain highways, see AS 15.40.

## Chapter 25. Protection and Use of State Highways and Roads.

### Article

1. Utilities in Highways (§ 19.25.010)
2. Outdoor Advertising (§§ 19.25.105, 19.25.123, 19.25.150)
3. Encroachments in Highways (§ 19.25.200)

### Article 1. Utilities in Highways.

#### Section

10. Use of rights-of-way for utilities

**Sec. 19.25.010. Use of rights-of-way for utilities.** A utility facility may be constructed, placed, or maintained across, along, over, under, or within a state right-of-way only in accordance with regulations adopted by the department and if authorized by a written permit issued by the department. The department may charge a fee for a permit issued under this section. (3 Stat VII title II ch 162 S.L.A. 1957, am 3-3 ch 106 S.L.A. 1977, am 4-36 ch 36 S.L.A. 1990)

**Effect of amendments.** The 1990 amendment, effective May 12, 1990, added the second sentence.

## Article 2. Outdoor Advertising.

### Section

105. Limitations of outdoor advertising signs, displays and devices
123. Fairbanks — Seward peninsula

### Section

- transportation and utility corridor
150. Unlawful advertising

**Sec. 19.25.105. Limitations of outdoor advertising signs, displays and devices.** (a) Outdoor advertising may not be erected or maintained within 660 feet of the nearest edge of the right-of-way and visible from the main-traveled way of the interstate, primary, or secondary highways in this state except the following:

(1) directional and other official signs and notices which include, but are not limited to, signs and notices pertaining to natural wonders, scenic and historic attractions, which are required or authorized by law, and which shall conform to federal standards for interstate and primary systems;

(2) signs, displays, and devices advertising the sale or lease of property upon which they are located or advertising activities conducted on the property;

(3) signs determined by the state, subject to concurrence of the United States Department of Transportation, to be landmark signs, including signs on farm structures, or natural surfaces, of historic or artistic significance, the preservation of which would be consistent with the provisions of this chapter;

(4) directional signs and notices pertaining to schools;

(5) advertising on bus benches or bus shelters if the state determines that the advertising conforms to local, state, and federal standards for interstate and primary highway systems.

(b) *[Repealed, 6-21 ch 94 S.L.A. 1980]*

(c) Outdoor advertising may not be erected or maintained beyond 660 feet of the nearest edge of the right-of-way of the main-traveled way of the interstate, primary, or secondary highways in this state with the purpose of their message being read from that travel way except those outdoor advertising signs, displays, or devices allowed under (a) of this section.

(d) Outdoor advertising may not be erected or maintained within the right-of-way of an interstate, primary, or secondary highway except that outdoor advertising is allowed on bus benches and bus shelters located within the right-of-way under the authority of a permit issued under AS 19.25.200, if the bus benches or bus shelters are located within a borough or unified municipality and the buses that stop at that location operate during the entire year. (3 ch 155 S.L.A. 1970, am 4-1, 2 ch 195 S.L.A. 1975, am 3-1 ch 30 S.L.A. 1980, am 3-21 ch 94 S.L.A. 1980, am 4-1 ch 6 S.L.A. 1987, am 3-2 ch 158 S.L.A. 1988)

# CANAD

APR 01 1995

April 1, 1995

Representative Norman Rokeberg  
State Capitol  
Juneau, Alaska 99801-1182

Dear Norm,

I would like to thank you and your staff for the support and interest you show in your district. The public meetings held March 11th received a good turn out; all we need now is for the general public to understand the steps that need to be taken to bring a wild bull under control.

In regard to House Bill NO.287, I would like to thank you and a special thanks to Shirley Armstrong for being persistent during such a busy period. I will make myself available on April 7th at 1:00 pm to participate in the teleconference to testify in support of this bill.

If I can be of any assistance to you please let me know and I will do my best to oblige.

Sincerely,

*Race G. Jones*

Race G. Jones

CANAD/President

Municipality  
of  
Anchorage



1111 E. 12th Ave.  
Anchorage, Alaska 99501-1111  
Telephone: (907) 463-4000  
Fax: (907) 463-4001  
Rick Mysterom Mayor

OFFICE OF THE MAYOR

December 2, 1994

Race G. Jones  
P. O. Box 111725  
Anchorage, AK 99511

Dear Mr. Jones:

I believe that a beautiful, clean city, will be a great asset in our community's strategy to increase economic development and reduce crime and violence.

It is my vision to have Anchorage recognized as the city of lights and flowers and it will take the enthusiasm and cooperation of many organizations to bring this about. I am confident that a beautification program will give our citizens a sense of well-being and pride that will improve the quality of life for all concerned.

Thank you for sharing information with me on your plan for litter prevention. I wish you all the best.

Sincerely,

Rick Mysterom  
Mayor

DEPARTMENT OF COMMERCE AND  
ECONOMIC DEVELOPMENT

DIVISION OF ECONOMIC DEVELOPMENT

1601 C STREET, SUITE 724  
ANCHORAGE, ALASKA 99503-5337  
PHONE (907) 563-2165  
FAX (907) 562-0048

March 14, 1994

Mr. Race G. Jones  
PO Box 111725  
Anchorage, AK 99511

Dear Mr. Jones:

Thank you for sending me your new brochure and pictures of your litter receptacles. It looks as if you are making some real progress with your business plans. I agree that the phrase "support litter free streets" is a motto we should all get behind, whether public or private. The trash and garbage on our public streets is a disgrace.

The department has a policy of not endorsing an individual product, and I am sure you can understand why. I have worked with you in the development of the CANAD litter receptacles, however, and I think it is a quality product. With your permission we will add your name to our list of goods and services that we make available in response to inquiries.

I have appreciated the opportunity of working with you on this product and I wish you continued good luck.

Yours truly

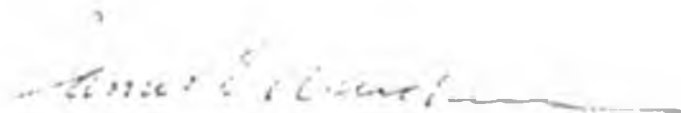

James E Wiedeman  
Development Officer

DEPARTMENT OF TRANSPORTATION  
AND PUBLIC FACILITIES  
OFFICE OF THE COMMISSIONER

WALTER J. HICKEL, GOVERNOR

3132 CHANNEL DRIVE  
JUNEAU, ALASKA 99801-7898

TEXT : 907 465-3652  
FAX : 907 586-8365  
PHONE : 907 465-3900

November 14, 1994

Mr. Race G. Jones, President  
CANAD  
P.O. Box 111725  
Anchorage, AK 99511

Dear Mr. Jones:

Thank you for your letter of October 21, 1994. I had my staff research the conditions surrounding your request to install litter receptacles in our right-of-way. Due to the fact that both Alaska Statute 19.25.110 and Alaska Administrative Code 20.010 only allow advertising on bus benches and bus shelters, this Department does not have statutory authority to approve your request.

The Department recognizes the benefit that the litter receptacles could offer. However, until the Alaska Statutes are changed our hands are tied.

I am sorry I could not have been more helpful in this matter.

Sincerely,

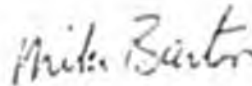

Michael A. Barton  
Commissioner

Municipality  
of  
Anchorage



5800 E. 34th Avenue  
Anchorage, Alaska 99516  
Telephone (907) 343-3333  
Fax (907) 343-3338

ANCHORAGE ASSEMBLY  
Pat Abney  
Assembly Member

March 8, 1994

Race G. Jones, General Manager  
CANAD  
P.O. Box 111725  
Anchorage, Alaska 99511-1725

Dear Race:

Thanks for taking the time to meet with me last week in regards to your proposal to address the problem of litter on our city streets. I think your idea of starting this program in the downtown business area is innovative and will prove to be well-received.

You mentioned that you were seeking assistance with the installation and service of litter receptacles and working on draft revisions to the right of way ordinance. It sounds as if you are doing everything to work with the appropriate officials to get this program underway.

I look forward to hearing from the Urban Design Commission regarding their recommendations and suggestions related to your proposal.

Let me know if I can be of further assistance. You may consider this letter my statement of support for the litter-free streets program in Anchorage.

Sincerely,

Pat Abney  
Assembly Vice-Chair

MUNICIPALITY  
OF  
Anchorage



111195002 037 24 11 94

Mark Begich, Vice Chair  
Anchorage Assembly  
P.O. Box 201027  
Anchorage, Alaska 99520

March 1, 1994

Race G. Jones, General Manager  
CANAD  
P.O. Box 111725  
Anchorage, Alaska 99511-17125

Dear Race:

Thanks for a most informative letter about your innovative program to address the problem of litter on our city streets. I think the idea of starting your program in the downtown business district is great! I am very interested in the concept and totally support your proposal.

You mentioned that you were seeking assistance with the installation and service of litter receptacles and working on draft revisions to the right of way ordinance. Let me know how I can help.

I look forward to hearing from you.

Sincerely,

  
Mark Begich  
Assembly