

S

B

Z

Z

7

Senator Vic Fischer

Alaska State Legislature
Pouch V • Juneau, Alaska 99811 • (907) 465-4954



May 16, 1983

TO: All Senators

FROM: Senator Vic Fischer

RE: SB 227--Alaska Council on Science and Technology

SB 227 continues the existence of the Alaska Council on Science and Technology but extensively modifies its purpose and functions. The main features of this bill are:

- 1) repeal of the council's grant making authority (sec 4);
- 2) repeal of the northern technology small grants program (sec 5);
- 3) elimination of the laundry list of purposes, powers and duties of the council (streamlining of functions);
- 4) gives the council a role in development and implementation of federal Arctic Science Policy;
- 5) moves the council to the Office of the Governor (OMB);
- 6) removes designated seats on the council and increases size to nine members; and,
- 7) continues the council through 1987.

I believe this bill meets most of the needs and concerns of the legislature, the governor's office, and the Alaska scientific community. It should assist Senator Murkowski in promoting the Arctic Research and Policy Act. It repeals the grants process which has generated concern among some legislators. It meets the Governor's need for scientific advice within the OMB. It allows for greater private sector involvement on the council.

SB 227 is the result of an extensive sunset hearing held jointly by the Senate and House State Affairs Committees. It has the support of the Governor as well as the council itself. The bill has a zero fiscal note because the council is a reduced continuation item in the Governor's budget (less than 50% of last year's budget).

I. REQUEST

II. FISCAL DETAIL

Bill/Resolution No.: SB 227 Agency Affected: Office of the Governor
 Title: "An Act relating to the AK Council on Science & Tech. BRU, Program of Subprogram(s) Affected: Exec. Operatio
 Sponsor: State Affairs Requestor: Sen. V. Fischer & providing for an effective date."
 OMB

EXPENDITURES/REVENUES: (Thousands of Dollars)

	FY 83	FY 84	FY 85	FY 86	FY 87	FY 88
OPERATING						
100 PERSONAL SERVICES		-0-	-0-	-0-		
200 TRAVEL		-0-	-0-	-0-		
300 CONTRACTUAL		-0-	-0-	-0-		
400 COMMODITIES		-0-	-0-	-0-		
500 EQUIPMENT		-0-	-0-	-0-		
600 LAND & STRUCTURES		-0-	-0-	-0-		
700 GRANTS, CLAIMS, ETC		-0-	-0-	-0-		
TOTAL OPERATING		-0-	-0-	-0-		

CAPITAL						
---------	--	--	--	--	--	--

REVENUE						
---------	--	--	--	--	--	--

FUNDING: (Thousands of Dollars)

GENERAL FUND		-0-	-0-	-0-		
FEDERAL FUNDS						
OTHER (Specify Source)						

POSITIONS:

FULL-TIME		-0-	-0-	-0-		
PART-TIME		-0-	-0-	-0-		
TEMPORARY		-0-	-0-	-0-		

III. SOURCE OF FUNDS TO OFFSET FISCAL IMPACT OF BILL:

There is currently 100.0 for FY 84 for the Alaska Council on Science and Technology within the Office of Management and Budget/Division of Strategic Planning Budget.

IV. ANALYSIS: Attach a separate page for any Analysis

Prepared By: Michael A. Nizich, Director Phone: 465-3616
 Division: Administrative Services Date: 4/6/83
 Approved by Commissioner: *Lawrence J. Yerman* Date: 4/6/83
 Department: Office of the Governor

Distribution:

- Original to Legislative Finance
- Copy to Office of Management and Budget (for Legislature introduced bills)
- Copy to Department (for Governor introduced bills)
- Copy to Sponsor
- Copy to Requestor (if different from Sponsor)

A

Editor's note. — Section 1, ch. 149, SLA 1977, provides: "The legislature finds that the substantial increase in the number of state agencies, boards and commissions, and the proliferation of rules and regulations which each has adopted have contributed to a public disenchantment with the operation of state government, and that there is need for an effective and regular system of scrutiny of the programs and activities of

all agencies, boards and commissions. The legislature further finds that the establishment of a system for periodic review by the public and the executive and legislative branches of certain state agencies, boards and commissions will help the governor and the legislature to determine the need for the continued existence of each of the agencies, boards and commissions."

Sec. 44.66.010. Termination of state boards and commissions.
 (a) Boards and commissions listed in this subsection expire on the date set out after each:

- (1) Alcoholic Beverage Control Board (AS 04.06.010) — June 30, 1981;
- (2) Alaska Transportation Commission (AS 42.07.011) — June 30, 1983;
- (3) State Board of Parole (AS 33.15.010) — June 30, 1980;
- (4) Alaska Public Utilities Commission (AS 42.00.010) — June 30, 1985;
- (5) Alaska Pipeline Commission (AS 42.06.010) — June 30, 1981;
- (6) Alaska Council on Science and Technology (AS 44.19.181) — June 30, 1983;
- (7) Alaska Renewable Resources Corporation (AS 37.12.010) — June 30, 1982;
- (8) Alaska Code Revision Commission (AS 24.20.075) — June 30, 1982;
- (9) Rural Development Council (AS 44.47.160 — 44.47.190) — June 30, 1987.

(b) Upon termination, a commission listed in (a) of this section shall continue in existence until June 30 of the next succeeding year for the purpose of concluding its affairs.

(c) A commission scheduled for termination under this chapter may be continued or reestablished by the legislature for a period not to exceed four years. (§ 3 ch 149 SLA 1977; am § 3 ch 101 SLA 1978; am § 10 ch 179 SLA 1978; am § 3 ch 44 SLA 1980; am § 1 ch 115 SLA 1980; am § 11 ch 131 SLA 1980; am § 11 ch 136 SLA 1980; am § 3 ch 172 SLA 1980)

Effect of amendments. — The first 1978 amendment added paragraph (6) of subsection (a).

The second 1978 amendment added paragraph (7) of subsection (a).

The first 1980 amendment substituted "(AS 04.06.010) — June 30, 1981" for "AS

04.06.010 — June 30, 1979" in paragraph (1) of subsection (a).

The second 1980 amendment substituted "1983" for "1979" at the end of the paragraph (2) of subsection (a).

The third 1980 amendment substituted "1985" for "1980" at the end of paragraph (4) of subsection (a).

The f
paragra

Sec.
activit
provid
legisla

(1) I
protect

(2) I
sity of

(3) I
Janua

(4) I
mana

(b) I
shall l

conver

termin

Budge

if und

Sec

sessio

Legisl

than i

progr:

fiscal

Comm

legisl

termi

1 of t

Sec

dissol

unde:

44.66
shall
in th
heari
depar
board
or cc
comr.
comr.
37.07
comr
divis

ssions. The that the or periodic ecutive and ain state ssions will islatore to continued ies, boards

The fourth 1980 amendment added paragraph (8) of subsection (a).

The fifth 1980 amendment added paragraph (9) of subsection (a).

Sec. 44.66.020. Agency programs. (a) Agency programs and activities listed in this subsection which are specifically designated as provided in AS 44.66.030 are subject to termination during the regular legislative session convening in the month and year set out after each:

- (1) programs in the budget categories of general government, public protection, and administration of justice — January, 1980;
- (2) programs in the budget categories of education and the University of Alaska — January, 1981;
- (3) programs in the budget categories of health and social services — January, 1982;
- (4) programs in the budget categories of natural resources management, development and transportation — January, 1983.

(b) An agency program or activity designated in (a) of this section shall be subject to termination during the regular legislative session convening four years after the preceding review and may be subject to termination at any time upon the recommendation of the Legislative Budget and Audit Committee and the concurrence of the legislature as if under AS 44.66.030. (§ 3 ch 149 SLA 1977)

Sec. 44.66.030. Program identification. During the legislative session preceding each of the years set out in AS 44.66.020, the Legislative Budget and Audit Committee shall designate, not later than March 1 of those years, the programs and activities within each program category which shall be subject to termination in the next fiscal year. The recommendations of the Legislative Budget and Audit Committee shall be submitted to the respective houses of the legislature in the form of a bill which, if enacted into law, would terminate those designated programs and activities on or before July 1 of the following year. (§ 3 ch 149 SLA 1977)

Sec. 44.66.050. Legislative oversight. (a) Before the termination, resolution, continuation or reestablishment of a board or commission under AS 08.03.010 or AS 44.66.010, or of an agency program under AS 44.66.020 and 44.66.030, a committee of reference of each house, which shall be the standing committee of legislative jurisdiction as provided in the Uniform Rules of the Legislature, shall hold one or more hearings to receive testimony from the public, the commissioner of the department having administrative responsibility for each named board, commission, or agency program, and the members of the board or commission involved. The hearings may be joint hearings. The committee shall also consider the proposed budget of the board, commission, or agency program, prepared in accordance with AS 37.07.050(f), and the performance audit of the activities of the board, commission, or agency program, prepared by the legislative audit division as prescribed in AS 24.20.271(1). The committee may consider

missions. the date
June 30,
June 30,
June 30,
0, 1981;
3.181) —
.010) —
June 30,
— June
ion shall
r for the
pter may
d not to
1978; am
115 SLA
m § 3 ch
paragraph
mendment
the end of
al,
ubstituted
paragraph

any other report of the activities of the board, commission or program, including but not limited to annual reports, summaries prepared by the Legislative Affairs Agency, and any evaluation or general report of the manner of conduct of activities of the board, commission, or agency program prepared by the office of the ombudsman.

(b) During a public hearing, the board, commission or agency shall have the burden of demonstrating a public need for its continued existence or the continuation of the program, and the extent to which any change in the manner of exercise of its functions or activities may increase efficiency of administration or operation consistent with the public interest.

(c) A determination as to whether a board or commission or agency program has demonstrated a public need for its continued existence shall take into consideration the following factors:

(1) the extent to which the board, commission or program has operated in the public interest;

(2) the extent to which the operation of the board, commission, or agency program has been impeded or enhanced by existing statutes, procedures, and practices which it has adopted, and any other matter, including budgetary, resource, and personnel matters;

(3) the extent to which the board, commission or agency has recommended statutory changes which are generally of benefit to the public interest;

(4) the extent to which the board, commission or agency has encouraged interested persons to report to it concerning the effect of its regulations and decisions on the effectiveness of service, economy of service, and availability of service which it has provided;

(5) the extent to which the board, commission or agency has encouraged public participation in the making of its regulations and decisions;

(6) the efficiency with which public inquiries or complaints regarding the activities of the board, commission or agency filed with it, with the department to which a board or commission is administratively assigned, or with the office of the ombudsman have been processed and resolved;

(7) the extent to which a board or commission which regulates entry into an occupation or profession has presented qualified applicants to serve the public;

(8) the extent to which state personnel practices, including affirmative action requirements, have been complied with by the board, commission or agency to its own activities and the area of activity or interest; and

(9) the extent to which statutory, regulatory, budgeting or other changes are necessary to enable the agency, board or commission to better serve the interests of the public and to comply with the factors enumerated in this subsection.

(d) As to for purposes of the 60th day officer of the of the comm program wi with a sumn following:

(1) an ide and activiti address;

(2) a stat program of anticipated

(3) an ic conflicting c

(4) an ass of the progr

(5) an as commission program, or

(6) a just. the board, c in which it

(7) any o would impr with respec interest.

(e) The co reorganizat program. N shall be co board, comm of the bill.

Sec. 44.0 termination commission which is su the departr this chapte 1977)

(d) As to each board, commission, or agency program assigned to it for purposes of review, the committee of reference shall, not later than the 60th day of the legislative session, submit a report to the presiding officer of the house. The report shall contain a summary of the findings of the committee as to the compliance of the board, commission or program with the factors enumerated in (c) of this section, together with a summary or recommendations of the committee as to each of the following:

(1) an identification of the problems or the needs that the programs and activities of the board, commission or agency are intended to address;

(2) a statement, to the extent practicable, of the objectives of the program of the board, commission, or agency program, and its anticipated accomplishments;

(3) an identification of any other programs having similar, conflicting or duplicate objectives;

(4) an assessment of alternative methods of achieving the purposes of the program;

(5) an assessment of the consequences of eliminating the board, commission or program and consolidating its activities with another program, or of funding it at a lower level;

(6) a justification for the recommended continuation or extension of the board, commission or program, and an explanation of the manner in which it avoids duplication of or conflict with other efforts; and

(7) any other information which, in the opinion of the committee, would improve the performance of the board, commission or agency with respect to its representation of and responsiveness to the public interest.

(e) The committee of reference may introduce a bill providing for the reorganization or continuation of the board, commission or agency program. No more than one board, commission, or agency program shall be continued or reestablished in any legislative bill, and the board, commission, or agency program shall be mentioned in the title of the bill. (§ 3 ch 149 SLA 1977)

Sec. 44.66.060. Existing claims. This chapter shall not cause the termination or dismissal of a claim or right of a citizen against a board, commission or program of an agency terminated under this chapter which is subject to litigation. Claims and rights shall be assumed by the department to which the board or commission terminated under this chapter was attached for administrative purposes. (§ 3 ch 149 SLA 1977)

B

Editor's notes. — The Older Americans Act, P.L. 89-73, may be found in 42 U.S.C. § 3001 et seq.

Section 14 of ch. 79, SLA 1981, provides: "TRANSFER OF PROGRAMS AND RESPONSIBILITIES. The following programs transferred to the Older Alaskans Commission in the Department of Administration:

(1) the programs conducted under the Older Americans Act, P.L. 89-73, as amended, and the persons who administer those programs in the division of adult and aging services, Department of Health and Social Services;

(2) the programs conducted under AS 47.65.010 — 47.65.060, and the persons

who administer those programs in the division of adult and aging services, Department of Health and Social Services; and

(3) the Governor's Advisory Committee on Aging."

Section 15 of ch. 79, SLA 1981, provides: "CONTINUING RESPONSIBILITY OF THE DEPARTMENT OF ADMINISTRATION. This Act does not affect the responsibility of the Department of Administration for the Alaska longevity bonus program (AS 47.45.010 — 47.45.170) or the Alaska Pioneers' Homes (AS 47.25.010 — 47.25.110)."

Sec. 44.21.240. Definitions. In AS 44.21.200 — 44.21.240, "commission" means the Older Alaskans Commission. (§ 2 ch 79 SLA 1981)

Article 5. Alaska Council on Science and Technology.

Section	Section
241. Council established	254. Definitions
242. Purpose, powers, and duties	255. Short title
253. Records, reports	

Editor's notes. — This article derived from AS 44.46.070 — 44.46.110.

Sec. 44.21.241. Council established. (a) There is established in the Department of Administration the Alaska Council on Science and Technology. The council consists of seven members who are appointed by the governor upon the recommendations of the state's scientific, engineering, and related communities and organizations. Members have overlapping three-year terms, except that, of the first members, two have terms of one year, two have terms of two years, and three have terms of three years. Two members shall be selected from different executive departments of state government having significant research activities, two members shall be selected from the Alaska academic community, two members must have significant activities or direct interests in research and shall be selected from the general public, and one member shall be selected from the staff of the legislature. The council shall elect one of its members as chairman. A chairman may be elected for successive terms as chairman and serves until his successor is designated. Four members constitute a quorum.

(b) Council members receive no compensation but are entitled to the travel and per diem provided by law for members of boards or commissions. (AS 44.21.200; Executive Order No. 48, § 4 (1981))

Editor's Notes. — As enacted, this section was designated AS 44.21.200 and was renumbered by the revisor of statutes pursuant to AS 01.05.031(b).

Sec. 44.21.242. Purpose, powers, and duties. (a) The purpose of the council is to review and recommend the scientific and technological research needs of state government, to issue research grants and contracts, to oversee the issued grants and contracts, to promote high standards of research for the priorities proposed by the council, and to address stated legislative or administrative requests for research.

(b) The council may

(1) apprise itself of local, state, federal, and private research programs, activities, and needs;

(2) convene committees, task forces, conferences, public hearings, and other meetings necessary to carry out the council's purposes;

(3) award research grants and contracts on a fair and competitive basis and administer those grants and contracts;

(4) enter into agreements creating one or more systems of information exchange with any appropriate research funding sources;

(5) at the request of any state agency, enter into and administer, but not perform, the research under research grants and contracts funded by that state agency;

(6) investigate the need for and when necessary establish advisory committees for reviewing its program;

(7) request and receive from any agency of the state government the assistance and data needed to carry out the requirements of this section;

(8) hire an executive director and staff that may be necessary to implement AS 44.21.241 — 44.21.255.

(c) The council shall

(1) develop methods of surveying research needs of the state, based on the present and future information needs of policy makers, state agencies, and the public at large;

(2) annually review the research needs and propose priorities for funding;

(3) annually submit to the governor and the legislature the findings of the council, including a listing, description, ranking, and justification of research needs, and a commentary on significant research activities of the preceding year funded by the state and including the relationship of that research to the state's needs and priorities;

(4) promote and enhance standards for research activities for which the council has administrative oversight;

(5) establish review procedures for research proposals;

(6) at a time commencing

(7) e product prepar applic the fin

(8) c organi

(9) ther t

(10) able i counz

matic which 44.21

Rev 44.21.

44.21. by th 01.05 of the

St fina

acce pres and

(f gov atic

las ((A)

F tio

cil in

44 44 A

(6) at the request of either the governor or the legislature, advise in a timely fashion on inquiries concerning scientific investigation or comment;

(7) evaluate and forward to appropriate agencies and persons products of research activities funded by the council; the council shall prepare comments to accompany research reports summarizing the applications, importance, or further research needs demonstrated by the findings of council-supported research;

(8) coordinate its data and information needs with other research organizations in order to avoid unnecessary duplication;

(9) not conduct any research itself other than that necessary to further the purpose of the council as provided in (a) of this section;

(10) supply to any person or agency requesting assistance the available information on past or present research activities for which the council has information, except that the council shall not release information which may endanger the acceptance of any research proposal which is at the time competing with other proposals for funding. (AS 44.21.210; Executive Order No. 48, § 4 (1981))

Revisor's notes. — A reference to AS 44.21.200 — 44.21.240 was changed to AS 44.21.241 — 44.21.255 in subsection (b)(8) by the revisor of statutes under AS 01.05.031 to conform to the renumbering of the chapter.

Editor's notes. — As enacted, this section was designated AS 44.21.210 and was renumbered by the revisor of statutes pursuant to AS 01.05.031(b).

Sec. 44.21.253. Records, reports. (a) The council shall have its financial records audited by an independent certified public accountant. The internal auditor and legislative auditor shall jointly prescribe the form and content of the financial records of the council and shall be afforded access to these records at any time.

(b) Before January 15 of each year, the council shall submit to the governor and the legislature a comprehensive report describing operations and expenditures and the status of grants and contracts for the last preceding fiscal year.

(c) The provisions of AS 09.25.110 — 09.25.120 apply to the council. (AS 44.21.220; Executive Order No. 48, § 4 (1981))

Editor's notes. — As enacted, this section was designated AS 44.21.220 and was renumbered by the revisor of statutes pursuant to AS 01.05.031(b).

Sec. 44.21.254. Definitions. In AS 44.21.241 — 44.21.255, "council" means the Alaska Council on Science and Technology established in AS 44.21.241. (AS 44.21.230; Executive Order No. 48, § 4 (1981))

Revisor's notes. — A reference to AS 44.21.200 — 44.21.240 was changed to AS 44.21.241 — 44.21.255 and a reference to AS 44.21.200 was changed to AS 44.21.241 by the revisor of statutes under AS 01.05.031 to conform to the renumbering of this article.

C

A PERFORMANCE REPORT ON THE
DEPARTMENT OF ADMINISTRATION
ALASKA COUNCIL ON
SCIENCE AND TECHNOLOGY

December 1, 1982

Commissioner, Department
of Administration

Lisa Rudd

Deputy Commissioners, Department
of Administration:

Administrative Management
Personnel Management
Telecommunications

Anselm Staack
Eleanor Andrews

Alaska Council on Science and Technology

Chairman
Member
Member
Member
Member
Member
Member

David Hickok
T. Neil Davis
Mim Dixon
Richard R. Straty
Robert D. Burkett
Jay Hogan
Charles Webber

STATE OF ALASKA

AUDIT DIVISION
POUCH W
JUNEAU, ALASKA 99811

THE LEGISLATURE

BUDGET AND AUDIT COMMITTEE

January 6, 1983

Members of the
Legislative Budget and Audit Committee:

In accordance with the intent of Titles 24 and 44 of the
Alaska Statutes, the attached report is submitted for your
review.

A PERFORMANCE REPORT ON THE
DEPARTMENT OF ADMINISTRATION
ALASKA COUNCIL ON
SCIENCE AND TECHNOLOGY

December 1, 1982

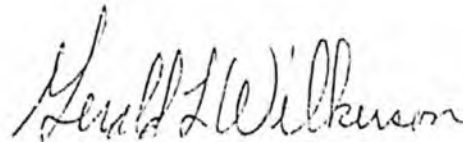

Gerald L. Wilkerson, CPA
Legislative Auditor
Division of Legislative Audit

TABLE OF CONTENTS

	<u>Page</u>
Purpose and Scope of the Report.	1
Organization and Function.	3
Report Conclusion.	5
Findings and Recommendations	7
Analysis of Public Need.	15
Appendixes:	
A. Summary of Questionnaires.	21
B. Appropriations Compared with Expenditures.	27
Agency Response:	
Council on Science and Technology.	29

PURPOSE AND SCOPE OF THE REPORT

Purpose

In accordance with the intent of Titles 24 and 44 (sunset legislation) we conducted an examination of the Department of Administration, Alaska Council on Science and Technology to determine if the Council has been operating in an effective and efficient manner and if there is a public need for the program.

As required by legislative intent this report shall be considered during the legislative oversight function in determining whether the Alaska Council on Science and Technology should be reestablished. The law currently specifies that this program will terminate as of June 30, 1983.

Scope

Our review consisted of evaluating the efficiency and effectiveness of the Council in (1) coordinating and centralizing research information in the State in order to identify and reduce unnecessary duplication, (2) determining and prioritizing State research needs; and (3) awarding and administering research grants in priority areas. We reviewed the following sources of information:

1. Applicable statutes and legislative intent
2. Budget documents
3. Research needs reports
4. Minutes of Council meetings
5. Correspondence files
6. Surveys of academic, private and governmental institutions
7. Surveys of Council members
8. Tests of records and documents of the Council, and
9. Any complaints filed with the Office of the Ombudsman, State Equal Employment Opportunity Office, or Human Rights Commission.

ORGANIZATION AND FUNCTION

The Alaska Council on Science and Technology was established by the 1978 Session Laws of Alaska, Chapter 101. There are seven Council members: two members are from executive agencies having significant research activities, two members from the Alaska academic community, two members from the general public who have significant activities or direct interest in research, and one member from the staff of the Legislature. Members are appointed by the Governor for overlapping three year terms.

The Council is organized under the Department of Administration which provides financial support. The Council has no regulatory function.

The Council was established to provide research data coordination through information centralization and review and to provide the scientific and technological community with a mechanism to advise decision makers on scientific issues. The purposes of the Council are as follows:

1. Review and recommend the scientific and technological research needs of State government
2. To issue research grants and contracts
3. To oversee the issued grants and contracts
4. To promote high standards of research for the priorities proposed by the Council
5. To address stated legislative or administrative requests for research.

REPORT CONCLUSIONS

Policy Issues

This report contains policy issues raised as a result of our evaluation of various Council endeavors. The final policy decisions affecting these endeavors are not within the scope of this review but require legislative consideration. In debating these issues, the legislative oversight committees should consider the findings and alternatives presented in this report so that the potential impact of policy changes can be evaluated.

Report Conclusions

In our opinion the continuation of the Alaska Council on Science and Technology is not necessary (see Recommendation No. 1).

In the event the Council is reestablished by the Legislature, certain changes need to be made to enable the Council to effectively and efficiently perform the duties intended by the Legislature, and to serve the public interest. These changes are outlined below.

1. Legislation should be introduced requiring State agencies and the University of Alaska to report to the Council on all research funded or contracted out during the year (see Recommendation No. 2).
2. The Council should comply with AS 44.21.242(C)(2) and (3) which require comment on significant State research activities and annual review of research needs. Additionally, the Council should more effectively prioritize research needs (see Recommendation No. 3).
3. The legislature should consider eliminating the authority of the Council to award research grants (see Recommendation No. 4).
4. The Council should formally review its performance in accomplishing the goals and objectives of the program (see Recommendation No. 5).

FINDINGS AND RECOMMENDATIONS

Recommendation No. 1

The Council on Science and Technology should be allowed to terminate.

We have reviewed the activities of the Council in relation to the enabling legislation and the statutory duties and obligations set forth in the Session Laws of Alaska 1978, Chapter 101. The review was performed in order to analyze the efficiency and effectiveness of the Council in meeting the objectives of the Legislature. The primary legislative goals were to coordinate and centralize research information in order to (1) provide concise, relevant scientific information from which informed policy decisions could be made; (2) discover and eliminate unnecessary duplicative research funded by public monies; and (3) to identify areas where research gaps exist. Furthermore, the legislature only intended the Council's coordination function to be a passive collection, commentary on, and dissemination of research information. The Council was never given the authority to actively control research funded by the State. It is in this sense that we use the term "coordination" in the following findings.

In the performance of our review, we found that the Council has been ineffective in meeting the objectives of the Legislature and in some cases has failed to fulfill statutory duties. Due to the analysis presented below, we believe the Council on Science and Technology should be allowed to terminate.

- A. The Council has been ineffective in coordinating statewide research information for the following reasons:
1. Research dollars are appropriated to other entities without requiring coordination with the Council. For example, the University of Alaska was appropriated \$47.7 million for organized research in Fiscal Year 1982. None of this research was coordinated through the Council.
 2. Other State agencies involved in research are not required to report to the Council about what research was funded or performed during the year. Council staff has suggested that some agencies do not consider that the Council's coordination function includes their research programs. Consequently, interaction with State agencies has been limited. Questionnaires received from agency personnel support the conclusion that the Council has had limited effect on State research programs. Some

State employees responding to our questionnaire were unaware of the existence of the Council. Due to this lack of interaction, substantial research monies are not coordinated by the council and any duplicative research has remained undiscovered.

3. Even though we realize that the Council has been limited in its ability to effectively coordinate research information because of the above problems, the Council has also been ineffective in gathering information on research available to them through departmental budget documents, session laws, and various reports required by the Legislature. The Council has limited itself to coordination of its own research budget which has totalled \$3.3 million from Fiscal Year 1979 to 1983. When compared to the University of Alaska's research budget alone, it is clear that the Council has had little statewide effect on research coordination or on reduction of unnecessary duplication.

On two separate occasions we have met and discussed our findings with representatives of the Council. After initial confusion over our use of the term coordination, the Council agreed that they do have a coordination function, as defined earlier in this report. Furthermore, the Council maintains that they have indirectly coordinated statewide research information by means of research needs reports, seminars, conferences, and policy proposals. However, we do not agree that this fulfills the Council's coordination function as envisioned by the Legislature.

The Legislature wanted information not only on research that needed to be done but also on research that was already completed or in progress. Additionally, this process of data collection was seen as a method to discover the use of public monies to fund research that was unnecessarily duplicative. By this the Legislature meant projects authorized and funded by one agency for information that was already available had the agency known of its existence.

Therefore, in our review of the Council, we expected to find a data file and retrieval system at the offices of the Council that would enable legislators or State agencies to readily obtain information on research in Alaska. For example, if a legislator wanted information on hydroelectric power research, he or she would be able to contact the Council and obtain information on projects completed, in

progress or contemplated by any State agency or the University of Alaska and the costs associated with that research. Also, he or she would obtain some commentary by the Council on the results of the research performed including whether it was relevant or valid.

Since we were unable to find information of this type at the Council Office, we concluded that the Council has been ineffective in this regard.

- B. The Council has not complied with the intent of AS 44-.21.242(c)(3) requiring comment on significant research activities funded by the State during the preceding year. This information is required to be in the Council's annual report to the Governor and the Legislature. The Council is hampered in fulfilling this requirement by its lack of knowledge of the types and cost of research funded by public monies. As stated in Section A., causes of this lack of knowledge are due in part to research monies being appropriated to other agencies without requiring coordination through the Council or without requiring agencies to report to the Council.

The Council maintains that they have complied with this requirement. We again reviewed the Council's annual report to determine if the intent of the legislation was fulfilled. The Council's annual report is, in our judgement, a general review of research topics of interest to the State. There is no report or commentary on significant research funded by the State during the preceding year as required by the statute. There is no accumulation of costs. We believe that this is due to a lack of detailed knowledge on the part of the Council as we saw no information of this type at the Council's Office.

- C. The Council is required by AS 44.21.242(c)(2) to annually review the research needs of the State of Alaska, as determined by the Council, and to prioritize those needs for funding. The Council has produced ten research needs reports since its inception, seven reports were prepared in 1980 and three in 1981. None of the needs reports have been annually reviewed and only one of the 1980 reports was revised in 1982.

Within the research needs reports, the Council listed ninety areas needing research. Eighty-five of these needs were listed as priorities in the 1981 annual report to the Governor and Legislature. We believe it would be more effective to limit the number of research needs identified as priorities because it is unrealistic to expect the Legislature to fund eighty-five projects.

Concise, effective presentation of research priorities should result in necessary research being funded by the Legislature.

The Council, on the other hand, maintains that their function is to identify research needs, while priorities for funding can only be determined by the Legislature. We can only reiterate that the Council is obliged to prioritize research needs and in our opinion, concise presentation of priorities is a more effective means of obtaining necessary research funding.

- D. According to AS 44.21.242(b)(3) the Council may award and administer research grants and contracts. We reviewed each research grant awarded since FY'81. During our review, we found that 79% of the grants were being awarded to the University of Alaska. Included in each research grant was a budget detailing costs for performance of the research. Each budget included overhead charged by the University for performance of research. These overhead charges ranged from 25% to 62% of the grant awarded less any expenditures budgeted for research equipment. Total overhead charged amounted to \$677,000 of the \$2,700,000 awarded to the University during Fiscal Years 1981 and 1982. At this same time the Council expended at least \$263,000 administering these same grants. We believe it is an inefficient use of public monies to unnecessarily increase research costs. Since the University of Alaska is receiving 79% of the grants and it is in the business of doing research it would be more efficient to directly appropriate the funds to the University thus saving the State, in this case, at least \$263,000.
- E. In addition to the above, we believe that the primary objectives of the Council are essentially duplicative of functions presently performed by the Arctic Environmental Information and Data Center (AEIDC), University of Alaska, Anchorage. AEIDC's Information Services section performs research data accumulation and centralization functions with the objectives of creating an awareness of research performed or being performed in Alaska, of identifying research needs or gaps, and to aid in avoiding unnecessary duplication of research. AEIDC publishes a yearly Current Research Profile from information accumulated in its data files. This profile outlines research performed in Alaska by subject, investigator, and funding source. This profile and the data files are the basic tools needed for coordination of research information. We believe that it would be more efficient to coordinate research through AEIDC because it is presently equipped with the necessary tools for statewide data collection and retrieval.

In discussions with the Council, they have maintained that AEIDC has no primary objectives in determining and prioritizing research needs or in advising State policy makers, obligations which are important Council functions. Furthermore, the Council states, AEIDC's functions are information storage and retrieval, data dissemination, and problem solving. However, in a publication put out by the Council titled "Scientific and Technological Research Needs in Alaska", a result of joint meetings of the Council and the Polar Research Board, the supervisor of AEIDC Information Services stated the objectives of AEIDC included identifying research needs or gaps and aiding in avoiding unnecessary duplication. Also, in a research grant proposal written by a researcher employed at AEIDC, there is the statement that AEIDC does answer requests for information from governmental entities or in effect, gives advice as to what information is available and what is unknown. Additionally, the Council has stated that it uses the resources of AEIDC to perform its functions of information dissemination.

This evidence supports our conclusion that AEIDC does perform similar functions also attributed to the Council. AEIDC serves as a data collection and retrieval center, identifies research needs or gaps, and on request advises governmental entities on research information. In our judgement, AEIDC is a practical, cost effective alternative to the Council on Science and Technology.

We base our recommendation for allowing the Council on Science and Technology to terminate on our perception of the evidence presented above. However, if the Legislature determines that continuation of the Council is in the best interest of the public, the following recommendations should be implemented.

Recommendation No. 2

Legislation should be introduced requiring all State agencies to report to the Council on all research contracted or performed during the year.

As addressed in section A, the Council has little tangible information and no control over almost all of the monies appropriated each year for research. Coordination in this type of situation is nearly impossible. Attempts to centralize information is made very difficult and time consuming when extensive researching of agency documents is required. Since it is unrealistic to expect all monies for research to be appropriated to the Council, a reasonable alternative is to require all agencies with research budgets to report to the Council on the ultimate allocations and

expenditures of those funds. This would result in a more efficient means of collection and analysis of research information.

Recommendation No. 3

The Council should fulfill its statutory obligations as stated in AS 44.21.242(c)(2) and (3).

- A. As addressed in Section B. of the preceding analysis, the Council has not commented in its annual report on the significant research activities funded by the State during the preceding year. Since the Legislature requires this information, we recommend the Council comply with this requirement.
- B. As addressed in Section C., the Council does not review or effectively prioritize its research needs. We recommend the Council comply with the requirement to annually review its research needs reports. We also recommend the Council rank its priorities by some criteria that would establish a direct relation to policy issues facing decision makers and limit the priorities to a realistic number.

Recommendation No. 4

The Legislature should consider eliminating the authority of the Council to award research grants.

As addressed in Section D. of the preceding analysis, the University of Alaska has received most of the research budget appropriated to the Council. By funnelling the money through the Council, unnecessary costs of at least \$263,000 have been added to the cost of the research. Additionally, the Council has spent a large percentage of its time in reviewing, awarding and administering the grants to the detriment of its other duties. We do not believe that elimination of the authority to award research grants will adversely affect the ability of the Council to coordinate research information, if State agencies are required to report to the Council. Effective coordination can be accomplished by concise reports to the Legislature and Governor on projects funded that were unnecessarily duplicative, poorly done or invalid. Research needs can be effectively presented by analysis of information obtained from agency and University reports to the Council.

Recommendation No. 5

The Council should formally review its performance in accomplishing the goals and objectives of the program.

Periodic performance reviews are a valuable tool in measuring the effectiveness of management policies in achieving program goals. Areas needing improvement or redirection can be identified and procedures updated to more effectively meet management's requirements. These reviews should result in information beneficial to the Council and can be used to measure its success in meeting program objectives.

ANALYSIS OF PUBLIC NEED

Limited Analysis

The following evaluations of the Council's activities relate to the public need factors defined in the "sunset" law. These evaluations are not intended to be all inclusive, but address those areas we covered in our review.

- I. The extent to which the board, commission or program has operated in the public interest.
 - A. The Council has promoted high standards in the research it has funded.
 - B. The Council has made an attempt to inform the public about new technologies and scientific advances through support of symposiums and conferences in Alaska.
 - C. The Council has been involved in developing an arctic research policy culminating in a bill before the United States Congress.
 - D. The Council has identified various research needs of Alaska and attempted to bring these needs before the public.

- II. The extent to which the operation of the board, commission, or agency program has been impeded or enhanced by existing statutes, procedures, and practices which it has adopted, and any other matter, including budgetary, resource, and personal matters.
 - A. The Council has been impeded in performing its statutory duties by the absence of any condition requiring State agencies and the University of Alaska to report to the Council concerning research funded or performed.

- III. The extent to which the board, commission or agency has recommended statutory changes which are generally of benefit to the public interest.
 - A. The Council has contributed to public discussions in an attempt to develop an Alaskan science policy which could lead to a more coordinated research program in Alaska.
 - B. The Council has assisted the Office of the Governor in development of an Alaskan position on the future of the Naval Arctic Research Laboratory. The fundamental Alaskan position was

to seek a federal/state partnership in both use and financing.

- IV. The extent to which the board, commission, or agency has encouraged interested persons to report to it concerning the effects of its regulations and decisions on the effectiveness of services, economy of services, and availability of services which it has provided.
- A. The Council has developed a peer review committee of scientists and technicians who review and comment on research proposals submitted to the Council. This has promoted high research standards in the research funded by the Council.
- V. The extent to which the board, commission or agency has encouraged public participation in the making of its regulations and decisions.
- A. The Council has made extensive use of the public in determining the research needs of Alaska. Scientists and technicians in government, education, and private industry have participated in workshops to discuss research needs. Various research needs reports have evolved from these meetings.
- B. The Council encourages public participation in its discussions by public announcement of its meetings.
- C. The Council participates in the Alaska Science Conference held each year in Fairbanks. Questions and comments concerning the Council and its function are solicited from interested parties.
- VI. The efficiency with which public inquires or complaints regarding the activities of the board, commission or agency filed with it, with the department to which a board or commission is administratively assigned, or with the Office of the Ombudsman have been processed and resolved.
- A. We found no instances where the Council did not respond to public inquires.
- B. We found three complaints handled by the Office of the Ombudsman. Each was resolved efficiently and to the satisfaction of the complainant. The Council implemented the recommendations of the Ombudsman.

- VII. The extent to which the board or commission which regulates entry into an occupation or profession has presented qualified applicants to serve the public.
- A. The Council does not have a licensing function.
- VIII. The extent to which State personnel practices, including affirmative action requirements, have been complied with by the board, commission or agency to its own activities and the area of activity or interest.
- A. We found no problems in this area.
- IX. The extent to which statutory, regulatory, budgeting, or other changes are necessary to enable the agency, board, or commission to better serve the interests of the public and to comply with the factors enumerated in this subsection.

Please refer to the previous section, Findings and Recommendations.

APPENDIXES

APPENDIX A

ALASKA COUNCIL ON
SCIENCE AND TECHNOLOGY FY'83
Summary of Questionnaires

Questionnaires were sent to 165 persons to obtain information about the Council from the public. All names were systematically chosen from a list of peer reviewers provided by the Council and from participants in the Council workshops on research needs. We received 70 responses to our questionnaires. All but eight responses were from the original persons contacted. Many of the responses included thoughtful written comments. Due to space limitations, comments had to be shortened, and many could not be included.

	Private Sector			Federal Government			Research Institutions			State Government			Total			
	Yes	No	Unknown	Yes	No	Unknown	Yes	No	Unknown	Yes	No	Unknown	Yes	No	Unknown	
1. Have you had any contact with the Council on Science and Technology?	11	2	0	21	0	0	17	0	0	15	4	0	64	6	0	
													91%	9%	0%	
If no, please make any comments you may have in the space provided at the end of this survey.																
2. The Council has the obligation to reduce duplicative research funded by the State. Do you feel the Council has been effective in meeting this goal?	6	1	1	12	0	5	10	3	3	7	5	3	35	9	12	
													63%	16%	21%	

If yes, please explain.

1. Attempt to guarantee monies they allocate are wisely spent.
2. Meetings help researchers get acquainted with each others activities.
3. Research needs reports.
4. Has reduced duplication with their own funds but this is a small portion of State funded research.
5. The Council has reduced duplication through their peer review committee.
6. Council emphasis on avoidance of duplication.

If no, how could they become more effective?

1. More information to the public and to scientists.
2. More level centralization of all research.
3. More time.
4. More than lipservice from State research agencies.

(Continued on next page).

	Private Sector			Federal Government			Research Institutions			State Government			Total		
	Yes	No	Unknown	Yes	No	Unknown	Yes	No	Unknown	Yes	No	Unknown	Yes	No	Unknown
5. Surveyed opinions on water resource needs but this survey was in itself duplicative of similar tasks by other agencies.															
6. Monitor all research for validity, quality.															
7. Need power to review and pass judgement on all funding.															
3. Are you aware of any instances where planned research was not funded because the Council advised that the information was already available?	1	10	0	3	14	1	4	12	0	0	15	1	8	51	2
													13%	84%	3%
4. Do you believe the Council has been successful in bringing the scientific and technological community into closer contact with State policy makers?	9	1	1	13	1	14	1	1	1	9	4	1	45	9	4
													78%	15%	7%
5. Are you aware of the research needs identified by the Council as priorities within Alaska?	8	3	0	18	3	0	14	1	1	8	9	0	48	16	1
													74%	25%	1%
If yes, do you feel they are relevant to State needs?															
1. Not only are they relevant, but they should be used by the Legislature and the agencies in the budget process.															
2. They have very successfully outlined State needs in arctic area.															
3. Yes, very much so, however, I also believe that scientific needs don't coincide with policies and doubt that needed work will be funded with out the usual political games.															
6. Do you feel the Council has influenced public policy on scientific issues facing the State?	4	3	3	7	5	8	9	4	4	3	6	3	23	18	18
													38%	31%	31%
Please explain.															
1. Not in business long enough.															
2. Has brought research needs before policy makers.															
3. Has not received needed publicity.															
4. Arctic Research Policy.															
5. Council is a candle in the darkness.															
6. Threats to shut the Council's Offices have led to some instability, uncertainty and loss of confidence.															

(Continued on next page).

	Private Sector			Federal Government			Research Institutions			State Government			Total		
	Yes	No	Unknown	Yes	No	Unknown	Yes	No	Unknown	Yes	No	Unknown	Yes	No	Unknown
7. Do you feel it is government's responsibility to promote scientific and technological inquiry?	13	0	0	21	0	0	16	0	0	14	2	0	64	2	0
													94%	6%	0%
8. If this program were eliminated what effect, if any, would it have on your agency, institution, company, or the public interest?															
1. State funding would be lost.															
2. The idea is good, should not be eliminated.															
3. Would lose valuable vehicle for those in research to bring forward research topics, also raises the quality of research.															
4. State government could lose its easy access to scientists.															
5. Coordination of state and federal research would suffer resulting in more potential for duplication.															
6. Loss of broad view of research needs.															
7. Would lose peer review committee															
8. ACST guided research to topics relevant to Alaska - if not continued research maybe less relevant.															
9. Vested interests too often get funded for "research" that has no relevance. ACST should have greater advisory status.															
10. Fourteen responses stated there would be little or no effect.															
9. Are there other organizations in the State performing the same duties?	2	5	1	1	18	2	2	12	1	7	5	3	12	40	7
													20%	68%	12%
Please list if yes.															
1. Appropriate Technology.															
2. Nearly every agency, school has research functions and policy roles.															
3. Department of Fish and Game.															
4. Geological and Geophysical Survey.															
5. Arctic Environment and Information Data Center.															
6. University of Alaska direct department budget funding.															
7. Many of the Council's tasks are duplicative of work done by other agencies.															
8. Individual agencies: APA, APEC, APUC, Dept. of Admin., Division of Telecommunications.															

(Continued on next page).

	Private Sector			Federal Government			Research Institutions			State Government			Total		
	Yes	No	Unknown	Yes	No	Unknown	Yes	No	Unknown	Yes	No	Unknown	Yes	No	Unknown
10. Do you believe there is a public need for this program?	11	0	0	21	0	0	16	0	0	12	3	1	60	3	1
													94%	5%	1%

Please explain.

1. ACST is a vehicle by which structured communication can flow back and forth between the technical and scientific community and the executive branch of government.
2. State needs to establish priorities.
3. Need a coherent program to define needs and priorities and to account publicly for them.
4. Make public aware of lack of information.
5. Need a statewide focal point for coordination of research efforts. I believe this role should be strengthened.
6. Reduce duplication (effective).
7. Provides a unique Alaska emphasis with more direct feed back to management agencies.
8. Need a coordinating mechanism for use of State funds.
9. Coordination provides more effective research.
10. The need is for an organization in state government to fund and promote research.
11. Needs tenure to be effective.

11. Any other comments?

Private Sector

1. Impressed by foresight in planning and implementation of the Council Connection to public policy is appropriately distant. If ties were too close the quality of science might greatly diminish.
2. Few ideas from Northern Technology available to the public.
3. Very high level reviews of proposals were obtained by donation of time, knowledge and experience by scientists in Alaska - at very low cost.

(Continued on next page).

4. I am concerned about the tone of this questionnaire. It seems to have missed the point on most important issues. I don't think ACST has been useful so far but the idea needs to be encouraged and the Council upgraded and given authority to be creative and useful - good idea badly handled.
5. Provides unbiased research - perhaps need an Alaska Science Foundation.
6. More funds for more research.
7. Need more publicity.

Federal Government

1. More publicity.
2. I was quite puzzled over what ACST was receiving for the overhead charge of 50% from the University of Alaska. Would like an itemization of overhead charges. In my opinion the Council's policy of not doing so could lead to misuse of public funds.
3. Needs to be better funded.
4. Council is to be commended on the development of the peer review process.
5. Public needs someone to ensure that only relevant, broad-reaching research is funded.
6. ACST should institute a policy of not funding agencies outside the State if qualified and prepared agencies within the State are ready to do the work.

Research Institutions

1. As a very active researcher on policy issues in Alaska, I see a strong need for ACST.
2. More publicity
3. Needs more funding. It is a relatively low cost program which has great potential. Needs to mature in procedures and priorities.
4. Council provides a scientifically sophisticated mentor for Alaskan decision makers.
5. The State has shown considerable wisdom in setting up the Council.
6. Budget should be increased by \$5,000,000 so they can effectively carry out the funding for Alaskan research problems.

(Continued on next page).

State Government

1. Should be similar to the National Science Foundation.
2. Must be assured existence for seven years.
3. The existence of this body is important but must have a breadth of knowledge about on-going research Statewide to make meaningful decisions.
4. Need a cleaning house activity to control and restrict duplicative research and to monitor overall quality of funded projects.
5. My impression is that ACST's advice was virtually ignored by the Legislature and Executive. Media reported on the grants program, otherwise it didn't seem to accomplish much.
6. Alaska could well profit from a carefully designed long range program of research and development in limited areas.
7. ACST has not had sufficient support to achieve its true potential as a policy guidance tool.
8. Can provide focus on research needs and a forum for exchange.
9. Publish a list of on-going projects and projects under consideration.

APPENDIX B

ALASKA COUNCIL ON
SCIENCE AND TECHNOLOGY
APPROPRIATIONS COMPARED
WITH EXPENDITURES

For the Fiscal Years 1982 and 1981
UNAUDITED

	<u>1981-1982</u>		<u>1980-1981</u>	
	<u>Authorizations</u>	<u>Expenditures</u>	<u>Authorizations</u>	<u>Expenditures</u>
<u>Operating Programs</u>				
<u>General Government</u>				
Alaska Council on Science and Technology (operations)	<u>\$ 603,000</u>	<u>\$ 544,000</u>	<u>\$479,200</u>	<u>\$475,652</u>
<u>Capital Programs</u>				
<u>General Government</u>				
Alaska Council on Science and Technology (grants)	<u>2,500,000</u>	<u>972,000</u>	<u>300,000</u>	<u>28,845</u>
	<u>\$3,103,000</u>	<u>\$1,516,000</u>	<u>\$779,200</u>	<u>\$504,497</u>

Expenditures include encumbrances and are reported on a budgetary basis.
Amounts are per books.

(Intentionally left blank)



THE ALASKA COUNCIL ON SCIENCE AND TECHNOLOGY

February 2, 1983

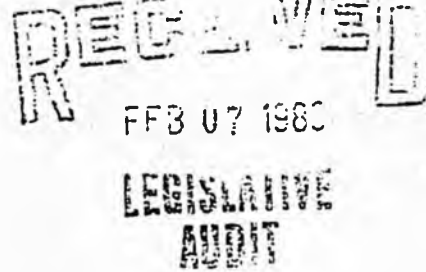

Mr. Gerald L. Wilkerson, CPA
Legislative Auditor
Division of Legislative Audit
Pouch W
Juneau, Alaska 99811

Dear Mr. Wilkerson:

This responds to your letter of January 17, 1983 enclosing a copy of "A Performance Report on the Department of Administration, Alaska Council on Science and Technology, December 1, 1982."

There are many errors and misconceptions in your report. These we discussed in our letter of November 30, 1982 and personally in your office on January 11, 1983.

The following summarizes our position on your report.

1. From the title of your report you imply that the Council is a line organization of the Department of Administration. This is not true; the legislative record is clear that the Council's affiliation with the Department of Administration is for administrative "house-keeping" purposes only.
2. The Council rejects your assertion that the legislative intent associated with its statutory establishment and duties was to coordinate and centralize research information. We believe a number of legislators and administrative personnel associated with the Council's establishment and operation can testify to this matter.
3. The Council asserts that it has functionally defined Alaska research needs. That these statements are currently valid and offer priorities by research function or field (i.e., Transportation, Minerals, Natural Hazards, Agriculture and Animal Husbandry, Health and Human Life, Communications, etc.). The Council rejects your assertion that it is charged with the prioritization of research across a spectrum of Alaskan societal concerns. Such prioritization can only be done by policy makers in the executive and legislative branches; and properly so.

Comments on many of the details of your report are contained in our letter of November 30, 1982. The Council reaffirms the content of that letter, rather than to repeat its substance here, since there are clearly

Mr. Gerald L. Wilkerson
February 2, 1983
Page Two

basic differences of opinion between your office and the Council on a number of matters. These differences we view as honest questions of interpretation and here express our appreciation for the professional and courteous manner in which your staff conducted its analysis of Council affairs.

Sincerely,

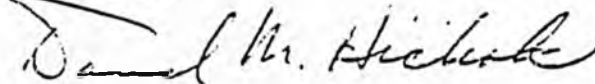

David M. Hickok
Chairman

DMH:pb

cc: L. Rudd, Commissioner, Department of Administration
C. Noah, Executive Director, ACST

Alaska State Legislature



RECEIVED
MAR 7 1983

Speaker of the House of Representatives

Pouch V
State Capitol
Juneau, Alaska 99811
(907) 465-3720

Official Business

March 7, 1983

TO: Rep. Mitch Abood
Chairman, State Affairs Committee

FROM: Joe L. Hayes
SPEAKER OF THE HOUSE *JLH*

SUBJECT: Sunset Legislation: Alaska Council on
Science and Technology

Attached is the audit report prepared by the Office of Legislative Budget and Audit for the Alaska Council on Science and Technology for review by your committee. Normal procedure is for the responsible committee to initiate legislation extending the life of the agency to a specified date, then if the Legislature elects to sunset it, the bill will either be defeated or allowed to die.

STATE OF ALASKA

AUDIT DIVISION
POUCH W
JUNEAU, ALASKA 99811

THE LEGISLATURE

BUDGET AND AUDIT COMMITTEE

MAR 04 1983

March 3, 1983

TO: Honorable Joe L. Hayes
Speaker
House of Representatives

FROM: Representative Bob Bettisworth
Chairman
Legislative Budget and Audit Committee

SUBJECT: Forwarding of Sunset Audits

Enclosed are the remaining two sunset audit reports of Boards and Commissioners that will terminate June 30, 1983. They include the Alaska Council on Science and Technology and the Alcoholic Beverage Control Board. I am forwarding these reports to you so that they may be distributed to the appropriate standing committees you will designate to perform the legislative oversight function.

E

SMOKE DETECTOR TESTING

IN

RURAL ALASKA

**Alaska Council on Science and Technology
Fire Safety Task Force**

**Research Funded
by the
Alaska Department of Public Safety
and the Alaska Council on Science and Technology**

May 1982

Dear Reader:

The Alaska Council on Science and Technology is pleased to offer this report, *Smoke Detector Testing in Rural Alaska*. It results from an inceptive effort in cooperative problem-solving research in Alaska. The Alaska Department of Public Safety, concerned over rural fire safety and early detection, wanted to implement a program of smoke detector installations in the homes of rural, village Alaska. The problem was to determine the type of smoke detector best suited to the rural situation. Mr. James Messick, special assistant to the Commission of Public Safety, approached the council for help in this determination. The council assembled a volunteer task force of fire safety specialists, scientists, engineers, and other knowledgeable individuals to evaluate research results and report on them.

This report represents the findings of the resulting one-year study of equipment and attitudes. It contains much valuable information and provided needed data for the Department of Public Safety. We hope that this work is instrumental in improving fire safety in rural Alaska.

The Office of the Vice Chancellor for Research and Advanced Study, University of Alaska, Fairbanks designed and administered the research program in cooperation with the Department of Public Safety through their Village Public Safety Offices Program.



David M. Hickok
Chairman

Abstract

Residential fires are an extreme hazard in Alaska, particularly in rural areas where fire protection services are minimal to nonexistent. To address this problem the Alaska Department of Public Safety contracted the Alaska Council on Science and Technology to research the feasibility of, and best procedures for, implementing effective use of smoke detectors in rural residences. No particular type of detector or manufacturer was a standout choice of the individuals participating in this study. This was due to individual attitudes, and it appears that attitude will govern the effectiveness of a widespread program to install smoke detectors in rural Alaska homes. The Fire Safety Task Force recommends that the smoke detector portion of the fire safety program emphasize education and instruction of villagers.

TABLE OF CONTENTS

Introduction	1
Method	1
Data and Results	3
Discussion of Results	7
Conclusions and Recommendations	9

Figures	13
---------------	----

Appendices

A Background Information (available on request from ACST)	23
B Questionnaire	25
C Final Questionnaire	27
D Village Coordinators' Instructions	29
E Householder Instructions	35
F Householder's Log	37
G Monthly Visit Form	39
H Silencer Circuit	41

INTRODUCTION

Residential fires cause more deaths (per capita) in Alaska than in any other state. The safety hazard is particularly acute in the rural villages, which experience five times more residential fires than do Alaska metropolitan areas. To address this problem the Alaska Department of Public Safety planned to purchase smoke detectors to provide an early warning device for village homes. No empirical data existed on the types of smoke detectors that would function best in small, often one-room, houses. Therefore, the department contracted the Alaska Council on Science and Technology (ACST) to research the feasibility of, and best procedures for, implementing effective use of smoke detectors in rural residences. The ACST appointed the Fire Safety Task Force to design and implement the research program. A list of the members and affiliations of the task force follows.

William Hao, Fire Inspector, City of Fairbanks Fire Department and Governor's Task Force on Fire Prevention and Control

David Mather, Director, Health Department, Tanana Chiefs Conference

James Messick (ex-officio), Alaska State Troopers

Gerald Romick, Professor of Geophysics, Geophysical Institute, University of Alaska

William Shechter, Fire Chief, University of Alaska

Nancy Smoyer, Project Coordinator, University of Alaska

The task force developed a program to test several different brands of two basic types of smoke detectors to determine the best unit. Laboratory tests on detector sensitivity were performed both before and after field installation.

Rural houses in Alaska are typically 400-to-600-sq ft structures of log or frame construction with one main living area. Small bedrooms are built off to the side and are often separated from the main room by only a drape. The houses are usually heated by wood- or oil-burning stoves located in the main room. Cooking often takes place in the main living area.

A preliminary background study (Appendix A) on smoke detectors indicated several problems to be investigated to find the best smoke detector for rural Alaska homes and lifestyles. Two main types of smoke detectors are manufactured for home use—ionization and photoelectric detectors. Ionization detectors were expected to respond more quickly to cooking fumes, thus resulting in frequent false alarms. Exposure of either type of detector to unusually high or low temperatures could cause excessive battery drain or the alarm to go off as the temperature changed. Other potential problems included blowing dust and dirt built up by cooking and heating fumes and smoke.

METHOD

The Fire Safety Task Force was a temporary group formed by the ACST to direct and conduct the detector research program. Members of the group included faculty of the University of Alaska and representatives of the University of Alaska and City of Fairbanks fire departments, Tanana Chiefs Conference, Governor's Task Force on Fire Prevention and Control, and Alaska State Troopers. During the course of the project the task force met approximately 16 times to

design, implement, and evaluate the program. The task force decided on a research program that included both laboratory calibration and field testing of smoke detectors.

A total of six villages in coastal and interior areas served as field test sites. Galena, Tanana, and Fort Yukon were chosen as the interior villages; Nome, Shishmaref, and Teller as the coastal villages. Five households in each village tested three smoke detectors for a total of 90 smoke detectors field tested. Models and quantities of the detectors tested are shown below.

Type	Manufacturer	Model No.	Number Tested
Photoelectric	BRK	2000	18
Photoelectric	Chloride Pyrotector	30-77A	21
Photoelectric	Electro Signal Labs	912	21
Ionization	BRK	79R	10
Ionization	General Electric	8201-401	15
Ionization	Guardion	FB-1A	5

For each installation three detectors were mounted approximately three inches apart on a board, and the boards were distributed so that every village had a reasonable number of samples of each kind of detector. Only detectors using 9-volt alkaline batteries were used because of the unreliability of electricity in most villages. The sensitivity of the detectors was tested in a smoke box prior to installation and retested on completion of the project. A device to silence false alarms for a 10-minute period was installed in the detectors (Appendix A). In three villages this device was activated at installation; in the other three villages the silencing devices were hooked up at the discretion of assistants living in the villages (village coordinators), depending on the attitude of the householder to the false alarms.

Additional funding of \$5,000 to test the silencer adaptation was obtained from the ACST Northern Technology Small Grants Program after the task force determined that such a device was necessary to relieve the householders of the many anticipated false alarms. Another \$5,000 grant was similarly obtained to test the reaction of the detectors to the extremely cold and changing temperatures which could cause problems peculiar to rural Alaska homes. This latter program is still in progress.

The testing period began in mid-April 1981 and was projected to last six months, with a possible two-month extension into the winter months. An interim visit to the field test sites was made by the project coordinator after three months to troubleshoot problems and to evaluate the progress of the project with the use of a questionnaire (Appendix B). One village dropped out of the project at the end of the initial six-month period, and four elected to continue for two more months. (One other village, Fort Yukon, dropped out in June.) In December the project coordinator collected the smoke detectors from the villages. At the same time, a final questionnaire (Appendix C) was used to evaluate the performance of the smoke detectors and the attitude of the householders toward each type.

The village coordinator functioned as the contact between the villagers and the Fire Safety Task Force in Fairbanks. The Tanana Chiefs conference assisted in choosing the coordinators for the three interior villages. Village public safety officers acted as village coordinators for the two coastal villages. The Alaska State Troopers in Nome provided extensive and effective logistical

and escort support. Instructions for the village coordinators (Appendix D) and householders (Appendix E) were drawn up, as were logs for the village coordinators and householders to complete and send back to Fairbanks monthly. The Householder's Log (Appendix F) provided a record of false alarms including the date, time, cause, and silencing method. The village coordinators' Monthly Visit Log (Appendix G) recorded the results of their monthly visits, e.g., the status of the smoke detectors and the attitude of the householders. The village coordinators and householders each received a monthly payment upon receipt of their reports.

The test houses varied but had several characteristics in common relative to fire protection. Almost without exception there were no bedroom doors; curtains were often hung in the doorways. There was little stuffed furniture (particularly on the coast) which would be susceptible to smoldering fires. Beds, however, were often used as furniture. Oil was the primary heating source on the coast. Wood burning stoves were available as back up in six of the 15 houses. Fourteen of the 15 houses in the Interior used wood-burning stoves as the primary heat source.

In Teller two new one-bedroom Alaska State Housing Authority (ASHA) homes and three old houses, one of which was a large two-story house, were used. Four houses with very small living areas (approximately 12 x 16 feet) were utilized in Nome. Two of these houses had bedrooms off the main room and numerous occupants (5 and 9) and visitors. The fifth house in Nome was a larger, new, frame house with a peaked roof.

In Shishmaref the detectors were tested in two one-bedroom houses. One of these was a very small (12 x 20 feet) one-room house, and the other somewhat larger with three rooms. One house was quite large (24 x 28 feet) and had three cooking and heating sources.

In the Interior three-quarters of the homes were log, unlike the coast where there was none of logs. In Fort Yukon the living areas of three houses was approximately 12 x 18 feet with one or two connecting bedrooms. (The other two householders in Fort Yukon dropped out of the program almost immediately.)

One of the houses in Galena was a large two-story combination frame and log house with two heat sources and six occupants. Also, two very small frame houses were used—one with one room and one occupant and the other with two rooms and two occupants. Both had wood and oil heating sources. The remaining two houses had log with wood-burning stoves as the only heat sources.

Two smoke detector boards were removed from houses in Tanana after a short period. One was never reinstalled, but the other was placed in a house with a small living area (12 x 20 feet) and five occupants. The remaining three houses were all medium size (approximately 18 x 20-foot living area with several bedrooms). All burned wood for heat, and all had numerous occupants (4, 6, and 7).

Approximately 75% of all the householders had prior knowledge of or experience with smoke detectors. One man, who was very fire conscious, had already installed several smoke detectors, including one he made himself. In the ACYIA and federal-program housing on the coast, smoke detectors had been installed when built and almost without exception been disconnected, whether battery or electric.

DATA AND RESULTS

The results of this study can be divided into two categories: detector performance and people's attitudes. The performance data were compiled from householder monthly logs and from laboratory testing of the detectors. The attitudinal data were gathered from the three periodic questionnaires and from general observations made throughout the project and, more specifically, during the visits to the villages.

The monthly reports from the householders of incidences of false alarms produced mixed results. In spite of efforts to insure reliable reporting, the inherent problems of human fallability resulted in erratic or unreliable reporting from at least 10 householders, particularly near the end of the test period. Also, a problem with low battery signals, which became evident almost immediately after installation of the detectors, decreased the usefulness of some of the data from the first three months.

Faulty C-MOS chips used as a part of the silencer adaptation (Appendix H) were found unexpectedly to be drawing power from the battery, thus causing many of the detectors to emit the sound that the device emits to signal low batteries. The resulting confusion and annoyance among the householders and village coordinators caused three householders to have the detector boards removed and some of the others to lose confidence in the detectors. This battery drainage problem was resolved in early July by cutting the silencer wire on 30 of the detectors during the interim visits by the project coordinator. At least four of the detectors were accidentally deactivated during this process. Eight boards were brought back to Fairbanks to replace the chips with a different kind; but only three of these boards were returned to the villages. (Fort Yukon dropped out of the program completely at this time.) Although some of the householders continued to change batteries quite often after the silencer deactivation, the monthly logs and village coordinator comments indicated far fewer low-battery signal occurrences.

The responses of householders to the silencer adaptation were varied. In addition to the original 15 houses equipped with silencers, only one was hooked up later. Although many people liked the idea of the silencer in principle, very few seemed to use it, usually because they needed a longer silencing period than the 10 minutes the silencer provided. They usually found it easier to remove the battery during the smoke-producing periods rather than repeatedly pushing the silencer button. Of the 15 householders who had a silencer from the beginning of the program, five of the 10 families who wanted a detector at the end opted for a silencer. Two of the other five families who were told about the possibility of a silencer wanted one.

An phenomenon revealed in the monthly reports and investigated during visits by the project coordinator was short single beeps of unidentified origin. These beeps were reported by at least eight householders, primarily in interior villages during summer. The beeps seemed to abate in the latter months of the testing period and were no longer reported as a serious problem. Although several causes of these beeps were hypothesized, including bugs, dust, low or high humidity, a bad chip, cosmic rays, and static electricity, nothing could be proved. New unidentified beeps in the colder months were probably due to the change in temperature. At least four householders related the cooling off of their houses to these alarms.

The performance or operational data of each smoke detector was obtained from the householder logs, which were designed to incorporate enough information to determine the cause of an alarm. The data from the logs on the number of alarms for each month were summed onto another form and sorted by detector model and village.

The total number of alarms, regardless of cause, was plotted for each detector model over the eight-month period to try to detect any systematic differences between the detectors. Figure 1 shows this plot normalized to the number of detectors of each type producing the alarms. No significant differences between the three photoelectric models were evident. The ionization detectors scored higher overall incidence of alarms, and the GE unit alarmed consistently more than either the BRK or Guardian models.

Because of problems with the silencer circuits and some detectors themselves, it was necessary to determine whether the statistics were biased for or against some detectors because of the actual number in service. Figure 2a shows the number of detectors of each type in operation over the test period each month, and Figure 2b shows the fraction of each detector model in operation each month. Except for the silencer problem in June (the problem was eliminated in

July), the fraction of each type in operation was similar for all models; it decreased about 30 percent during the first six months. The dropping out of another village in addition to Fort Yukon after the initial six-month period is the cause of the scatter in the data for October and November.

Figures 3a and b show the number of alarms, both known and unknown, normalized by dividing the total number of alarms by the number of detectors of each model. There appear to be more known alarms for both the GE ionization and the BRK ionization detectors. The cause is due primarily to cooking. The apparent high incidence of unknown alarms from the BRK photoelectric detector in Figure 3b was caused by reports from three houses in April, May, and September and is probably not indicative of any problem with that model detector.

The impact of characteristics peculiar to each village, such as location, house type and life-style, on the number of alarms produced was investigated. Figure 4 is a plot of all alarms per village over the test period. Much of the scatter seen in the early months could be due to the silencer problem and consequent low battery alarms. No clear tendency for one village to consistently have more alarms than another village appears in the data after July. The number of alarms in certain villages was not due to the decrease in the number of detectors during the test period. The following list shows the percent of detectors in each village that operated during the entire test period.

Shishmaref	92.5%
Teller	79.2%
Galena	71.2%
Nome	69%
Tanana	65%
Fort Yukon	33%

Shishmaref had almost all of its detectors in operation for the entire test period of eight months. Fort Yukon had most of its detectors pulled out in June due to multiple problems with false alarms and the resulting high level of frustration of the householders and the village coordinator. The householders and village coordinator in Nome also opted to discontinue the program at the end of the initial six-month period. The remaining villages had similar percentages of operational detectors during the period. Thus, factors pertinent to individual village characteristics seem to play no major role in detector survivability.

The number and types of alarms with respect to various causes for houses characterized as <300 sq ft and >300 sq ft were examined (Figure 5). The square footage shown is of the main room in which the detector was located, which invariably included the kitchen. The greatest source of alarms (93%) in both room sizes was cooking activity. More cooking-related alarms occurred with ionization detectors than with photoelectric detectors. Of the remaining known alarms, approximately 40% was caused by wood-burning stoves and the others by miscellaneous factors, such as cigarette and Pic smoke. (Pic is a solid mosquito repellent that when lit repulses the pests.) There is an apparent greater incidence of alarms for both types of detectors due to heating with wood in smaller rooms compared to larger ones. However, false alarms of known cause occur more frequently in small rooms than in large ones, so room size may be the key factor. Also, there is a higher incidence of false alarms of unknown cause with photoelectric

detectors than with ionization detectors, regardless of room size. Of the total number of recorded alarms, both known and unknown, approximately 23% was unknown.

The detectors were tested for sensitivity in an adaptation of the standard UL smoke test box before distribution to the villages and after their return. Figure 6 illustrates the basic design and electrical circuit of the smoke box. A Pic coil was used to produce a uniform smoke of reproducible particle size and burning rate. The use of Pic provided another test, as many village homes use it liberally in the summer. It was important to determine how the detectors will react to this material.

Figures 7a and b give the results of the tests made on the detectors before they were installed and after their return approximately 11 months later. No cleaning or maintenance was performed on the detectors in the laboratory prior to retesting. Although there is some variation within each manufacturer's model of both types, all the detectors of a given model started out with generally the same percent obscuration per foot.* Within the scatter of the data Figure 7a shows that the average sensitivity of the photoelectric detectors changed very little if at all during this period, although the variation in sensitivity within each model increased. This increase may be due to effects of variable aging of the detector emitters (LED) or receivers as well as variation in cleanliness and collected dust. The changes of control detectors kept in the laboratory during the field test period were all within the observed standard deviation for that particular model. The sensitivity of these detectors varies from manufacturer to manufacturer (ESL 3.3%, BRK 2% and CP 1.3% obscuration per foot in this smoke box); however, all are within the 7% obscuration per foot UL limit.

Figure 7b illustrates the generally higher sensitivity of the ionization detectors (Guardion 0.3%, GE 0.5% and BRK 0.7% obscuration per foot) relative to the photoelectric detectors, at least to the smoke particles used for these tests. All of the ionization detectors had increased their sensitivity (Guardion 0.15%, GE 0.2% and BRK 0.24% obscuration per foot) by the end of the test period. Even the control detectors that were not used during the tests showed an increase in sensitivity of the same order in similar amount. Though it was not unexpected that ionization detectors increase in sensitivity due to dust accumulation, it is somewhat surprising that all makes and all detectors changed similarly. There are two possible reasons:

1. The number of small particles in the Pic used in the final tests may have been higher relative to larger particles than in the initial tests. Thus, the photoelectric detectors would experience no great change since they are primarily responsive to larger particles, whereas the ionization detectors would register more sensitivity than previously. The problem with this idea is that some ionization detectors were tested with the remains of the old batch of Pic, and they too indicate a similar higher sensitivity. Therefore, this seems an unlikely possibility.
2. Another possibility which is more alarming is that the conductivity in the reference side of the circuit due to the radioactive source is decreasing with time. This decrease in the radioactive source would act much like an increase in conductivity in the sample chamber and thus produce a higher background upon which only a small amount of smoke could trigger an alarm, thereby increasing the sensitivity of the detector.

*"Obscuration per foot" is the percent absorption of light per foot going through the atmosphere, which increases as the level of smoke increases.

DISCUSSION OF RESULTS

No clear-cut superiority of one type or model detector over another was found among those tested. Since cooking produced most of the alarms, however, any educational program should inform villagers that ionization-type detectors will sound off from cooking more often than photoelectric detectors. Although the photoelectric detectors produced more unknown alarms, this does not appear to be significant since the unknown alarms were only 23% of the total reported alarms. Also, many of these false alarms occurred in the early months and were probably due to low battery signals. The changes in sensitivity noted in our test of the two types of detectors over extended periods should be taken into consideration when determining the most reliable and effective detector for general village use. The increase in sensitivity of the ionization detectors may eventually produce a detector with such a high nuisance level that the homeowner disconnects it completely.

Perhaps the most interesting and potentially useful information gained from the study is the attitude of the householders to the smoke detectors. This seems to be the overriding factor in determining the acceptance and effectiveness of smoke detectors in village homes. The type or model of detector does not seem to be as important as the householder's feelings about fires, false alarms, and smoke detectors in general. At the end of the program three householders chose not to retain a detector; and 20 wished to keep one of the detectors. When asked which of the three detectors tested in their homes they would like to have and why, six chose the detector which had the most false alarms, seven the least, and five chose the detector with intermediate numbers of false alarms. Two chose the GE ionization detector because of the less offensive sound of the alarm it produced. Regarding the choice of detector by type, 10 people chose the ionization models (BRK-5, GE-5) and 10 the photoelectric (CP-7, BRK-3). However, within each of the four brands chosen, the reasons given were equally divided between which detectors gave the most, least, or moderate numbers of false alarms. The people who chose the detectors which sounded the most cited reasons such as, "You know it's working," "It doesn't just sit there," and "It's better to be too sensitive than not sensitive enough." Others found the sensitive alarms very annoying and preferred the less sensitive detectors. Several people chose on the basis of what they determined to be a reasonable smoke level to trigger the detector, saying, "It doesn't go off for no reason like the others" and "It went off when I opened the stove—the real thing."

In general the householders were willing to put up with a large number of genuine false alarms because of their belief in the life-saving value of the detectors. Almost all agreed that smoke detectors are good and useful. Families with children and people with prior experience with fire incidences expressed the strongest positive feelings. One woman with children said that she felt more secure with a smoke detector because it was like having "somebody else to watch for fire."

At least four people's appreciation of smoke detectors was heightened during the program because they had been warned of potential or actual fires by the test detectors. One woman in Galena was awakened by her detector alarming in response to burning cotton caulking in the stack of her wood-burning stove. Another woman in Fort Yukon was warned of a pan left on the stove while she was outside. During the first test month a man in Nome was alerted by his detectors when a relit, pot-type oil furnace flooded and overheated. A family in Galena found the false alarms so annoying that they asked that the detectors be removed at the end of the six-month period. Unfortunately, a few days later a stack fire occurred in their wood-burning stove, which persuaded them to buy a detector.

During the test period there were other unique motivational influences pertinent to the future success of a smoke detector distribution program. There were three motivational forces beyond those of the individual householders—the village coordinators, the monthly payments,

and the three visits by members of the task force. Numerous householders expressed the sentiment that they wouldn't have continued the program if it weren't for one or more of these factors.

The ambivalence of the householders to the silencer adaptation may be due to the initial problem of false alarms caused by low batteries over which the silencer had no control. As a result, some of the householders lost confidence in the effectiveness of the silencer saying, "It would be OK if it worked." It does not appear that the silencer would be worthwhile installing on a large scale. The task force recommends that a simpler solution to false alarms would be to install the detectors within reach so that the batteries could be removed during false alarm periods, thus requiring a wall-mounted model. Alternatively, a simple switch could be installed that disconnected the battery. However, neither of these suggestions would be UL approved.

Although the problem of low battery signals caused by the silencer draining the batteries was solved for the most part by cutting the wires to the silencers, the continued frequent changes of batteries could have been due to at least three factors. It is possible that the batteries were changed without provocation, as is indicated by the reduction with time of incidences of reported low battery signals. The village coordinators in at least two villages said that they changed some batteries monthly as a preventative maintenance measure even though there were no low battery alarms reported. It is also possible that the batteries were run down by frequent cooking false alarms, although, again, the number of battery changes did not necessarily seem to correlate with the frequency of false alarms. A third probable cause cited by several householders is that the lower temperatures in the homes at night reduced the battery voltage, thus producing false alarms. Therefore, the evidence indicates that battery changes in the rural homes will need to be more frequent than the one-year UL requirement. A parallel laboratory test of the effects of temperature on smoke detectors is being carried out using ACST small grant funds; the results will be reported separately.

The practicality of battery-operated detectors as compared to normal 110-v household electricity came into question because of the frequent battery changes even after the silencer wires were cut. Although electric detectors would resolve the problem of low battery signals, it is the collective opinion of the Fire Safety Task Force that battery-operated detectors are more effective for two reasons: First, installation of battery-operated detectors is much easier, particularly in existing houses, and would therefore make their distribution more widespread. Secondly, since it seems inevitable that there will be fairly frequent false alarms with any kind of detector in any kind of rural home, there must be a provision for silencing the alarm. The only quick means of disconnecting a wired-in electric detector is by destroying it (which had already happened frequently in homes where electric detectors were installed when built), whereas with a battery-operated detector the battery can simply be removed. Several of the householders seemed to find this method satisfactory, saying they removed the battery while baking or frying and then replaced it. In spite of the danger that the battery won't be replaced, the alternative of a destroyed detector is worse.

Observations and reactions by the householders and the task force to certain physical characteristics of specific models of detectors could prove useful in determining which model would be most effective. As previously stated, the reaction of the householders to the frequency of false alarms was so mixed for each model that no preference could be found. The ease with which a detector can be opened for removal of the battery during false alarms periods is crucial to detector acceptance. The detector which was easiest to open was the GE model. Its hinged cover stayed attached even while open. The two models with the pop-off tops (BRK and Guardian) were also relatively easy to operate. The ESL model which slides off its base was particularly difficult to remove because it was hard to remember whether the detector slides to the left or right, thus inviting banging it to move it. The Chloride Pyrotector model also was difficult to

open because it required aligning the detector to two runners on the base which is attached to the wall. Another problem with the CP model is that when the battery is removed the empty wires to which the battery attaches can get caught in the detector during replacement of the cover, making it nearly impossible to reopen.

The two methods of connecting the battery, a stationary terminal and a terminal attached to wires, affect the long-term effectiveness of the detectors. There is a potential for breaking the wires found in the GE, ESL, and CP models during removal and replacement of the battery. The disadvantage to the stationary terminals found in the BRK and Guardian models is that it is sometimes difficult to be sure that the battery is securely attached and will not slip out later.

CONCLUSIONS AND RECOMMENDATIONS

Although some decisions about the detectors can be made on the basis of laboratory tests and examination of householder reports, no particular type of detector or manufacturer was a standout choice of the individuals participating in this study. This lack of unanimity is due to the overpowering impact of individual attitudes. The detector that might respond only to a true fire could be unacceptable to householders because it did not go off enough for them to feel confident that it was working; others would be equally upset if the detector ever went off. Thus, it is attitude that will govern the effectiveness of a widespread program to install detectors, not the particular type or make of detector installed. The selection of one detector and its distribution will not in itself produce an effective early-warning device for the villagers.

The Fire Safety Task Force recommends that the smoke detector portion of the fire safety program emphasize education and instruction of villagers. Some specific findings of the project which would be useful to the villagers follow.

1. False alarms will almost certainly occur, perhaps frequently.
2. Ionization-type detectors will produce significantly more false alarms than photoelectric models with the indication that the number of false alarms will increase with age of the detectors.
3. Smaller rooms produce more false alarms, so the detector should be placed as far away from the cooking source as possible without losing its life-saving capability.
4. Although people's attitudes toward false alarms vary greatly, an appreciation of the life-saving value of smoke detectors can overcome objections to those alarms.

The awareness of fire danger and the life-saving value of smoke detectors was high among the householders in this study. Approximately 75% of the householders had prior experience with detectors. Other villagers may not have that interest. The village coordinators do not think that this project has had much effect in heightening the awareness of the general populace to the usefulness of smoke detectors.

The laboratory tests and householder logs led to certain conclusions about the detectors themselves, their installation and maintenance, and householder attitudes.

1. Field tests of 90 smoke detectors conducted during 1971 in six Interior and coastal Alaska villages indicate that the major problem with the use of smoke detectors in rural homes in Alaska is the occurrence of false alarms of known and unknown origin. These false alarms greatly affect the acceptance and usefulness of detectors in rural residences.

2. The attitude of the householders toward smoke detectors is more important than the choice of an ideal detector. Therefore, the education and instruction of the villagers about fires and smoke detectors is of primary importance.
3. There are no apparent village-to-village or regional differences that affect the technical operation of the smoke detectors.
4. The primary cause of known alarms is cooking (93%), and most cooking in village homes takes place in the main living area. Therefore, any detector should be located as far away from the cooking area as possible without losing its life-saving capability. To allow the householder to deactivate the detector by removing the battery during false alarm periods (which seems to be the most feasible solution):
 - a. The detector should be wall-mountable to allow easy access.
 - b. The detector should be easy to open in order to remove the battery without damage during false alarm periods. (Chloride Pyrotector and ESL detectors were particularly difficult to open.) The speed with which a householder can deactivate the alarm will determine whether the detector stays in use or not.
5. The installation of a silencer attachment to deactivate the detector for a 10-minute period, though potentially desirable, appears technically and economically unfeasible due to UL regulations. A more obvious solution to which most users resort (even those with a silencer) is to temporarily remove the battery from the detector during false alarm periods.
6. People prefer detectors which have the least irritating alarm signal. (Of the detectors tested, the chirping noise of the GE model was preferred.)
7. Persons with experience with fires are most likely to want smoke detectors in their homes.
8. A certain fraction of village householders is unlikely to retain smoke detectors in working order in their homes because of the problem of false alarms. Of those that will there is roughly equal division between those who prefer a detector which gives the least number, an intermediate number, and the highest number of false alarms.
9. Photoelectric detectors produce significantly fewer false alarms than ionization, particularly of the more frequent cooking-related alarms.
10. The sensitivity of the detectors changes over the course of the study period. Generally, ionization sensitivity increased and photoelectric sensitivity stayed constant. Increased sensitivity means more false alarms and a higher nuisance level with predictable irritation to the householders.
11. The detectors should be battery-operated rather than electric to encourage more widespread distribution and continued use.
12. Extreme temperature changes in the house may cause false alarms due to battery deterioration.

13. It will probably be necessary to change the batteries more frequently than the UL requirement of once a year.
14. Regular inspections of the detectors by the village public safety officer or other designated villager for encouragement and education of the householders will improve performance. However, the primary responsibility for the maintenance of the smoke detector should rest with the householder.
15. During the course of the test program there is no known instance of an actual incipient fire which was not warned against by any operating smoke detector. There were four or more instances of real fire warnings by detectors during the test period. Thus, on the basis of this test program and other input, the installation of smoke detectors in rural Alaska residences is a worthwhile endeavor likely to lead to reduced fire losses and fewer deaths.

With these considerations in mind the Fire Safety Task Force offers the following recommendations for the purchase and distribution of smoke detectors in rural Alaska.

1. If the Department of Public Safety wishes to pursue a fire safety program that incorporates smoke detector installations, it is imperative that major attention be given to education and instruction of the users. *The attitude of users toward the smoke detectors is more important than the choice of which detector is to be installed.* Two potential educational aides are pamphlets on smoke detectors to be prepared by a group such as the Literacy Council and public service announcements on television.
2. Regular visits by a fire safety person to inspect detectors and offer encouragement to the householders will increase the continued use of the detectors.
3. There are two categories of criteria for selection of a particular model of smoke detector—required and optional. Required characteristics include:
 - a. Photoelectric detectors because they are less susceptible to the primary cause of false alarms (cooking activities) in small, essentially one-room rural residences and are therefore least likely to be rejected by householders.
 - b. Battery-operated rather than electric.
 - c. Wall-mountable for easy access during false alarm periods.

Optional characteristics include:

- a. Less than 3% obscuration per foot level (ESL is the only model of those tested which does not meet this recommendation).
- b. Inoffensive alarm signal (such as the GE chirping sound).
- c. Battery replacement ease, e.g., a cover which is easily removable (preferably attached as with the GE model) and easily accessible battery clips or wires.

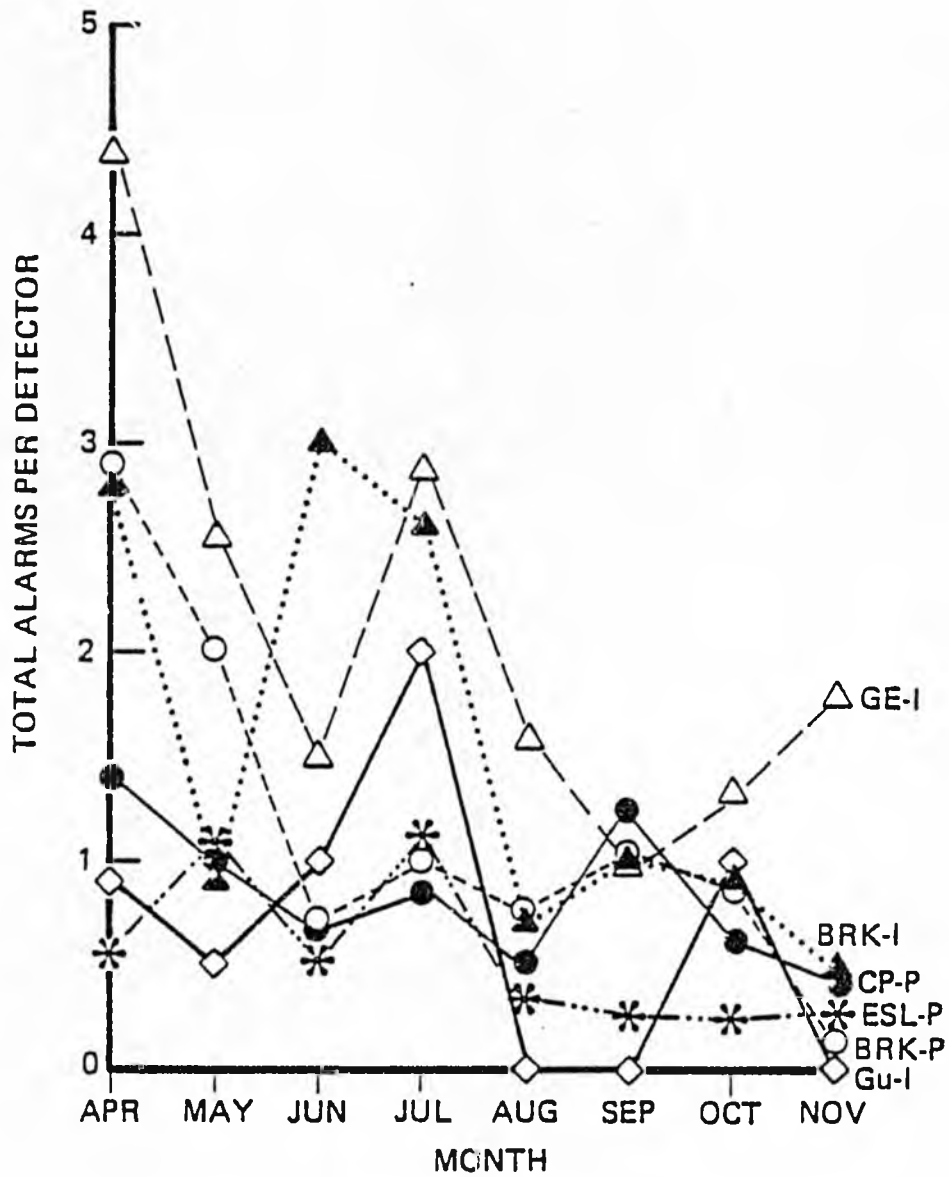

Figure 1. Total number of alarms per detector per month for the various brands over the test period.

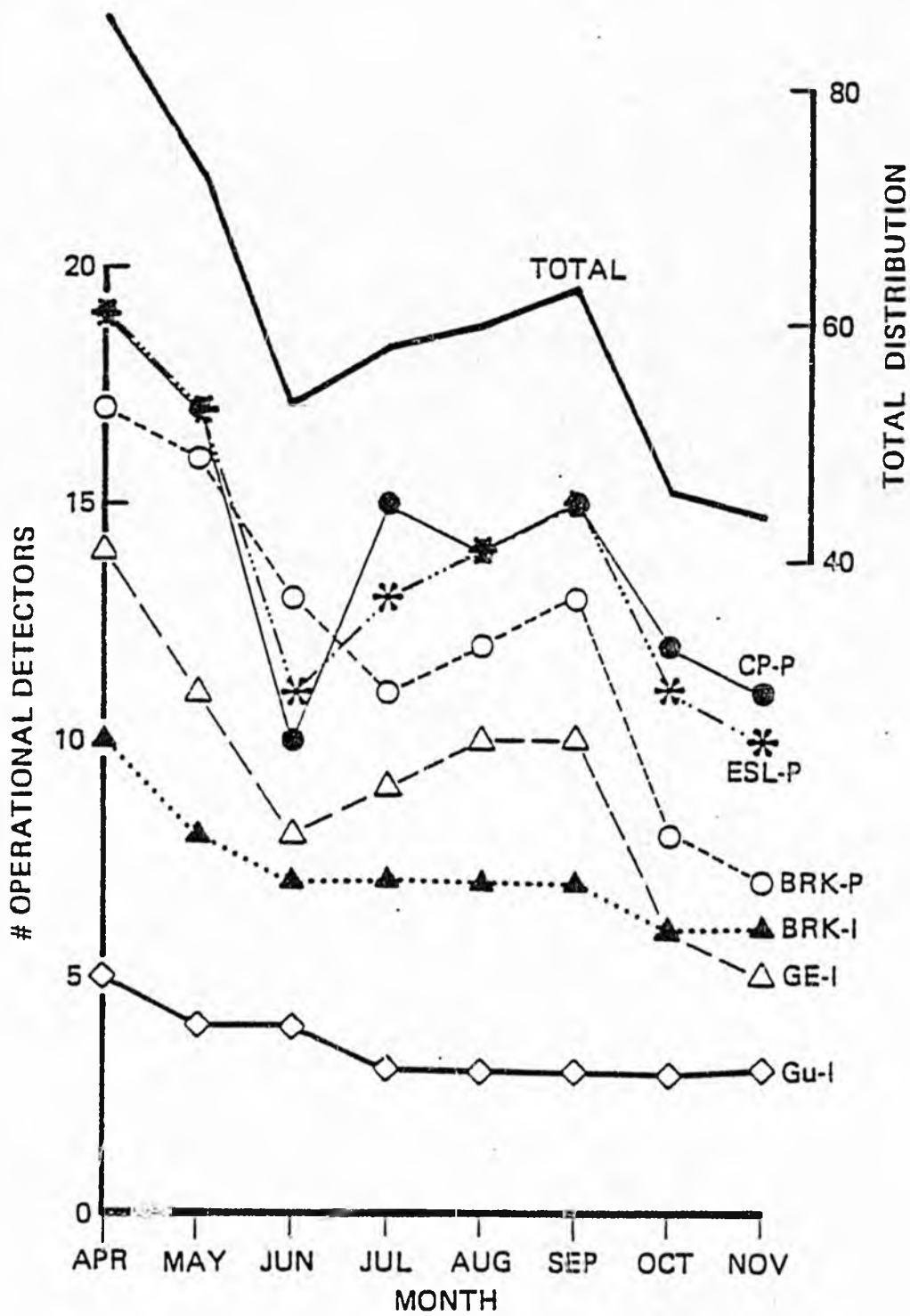

Figure 2a. Number of detectors of each brand group remaining operational each month during the test period. The total of all detectors in operation each month is indicated by the heavy solid line with numbers on the right.

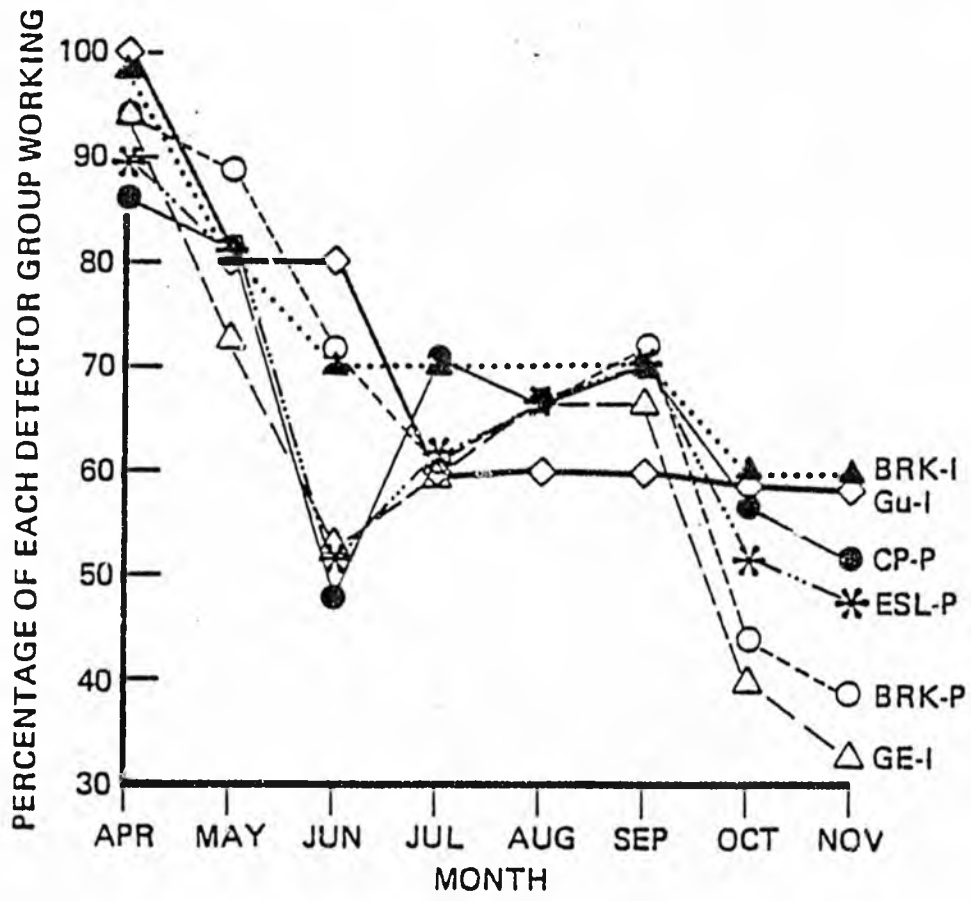

Figure 2b. Percentage of each detector brand group per month remaining in operation over the test period.

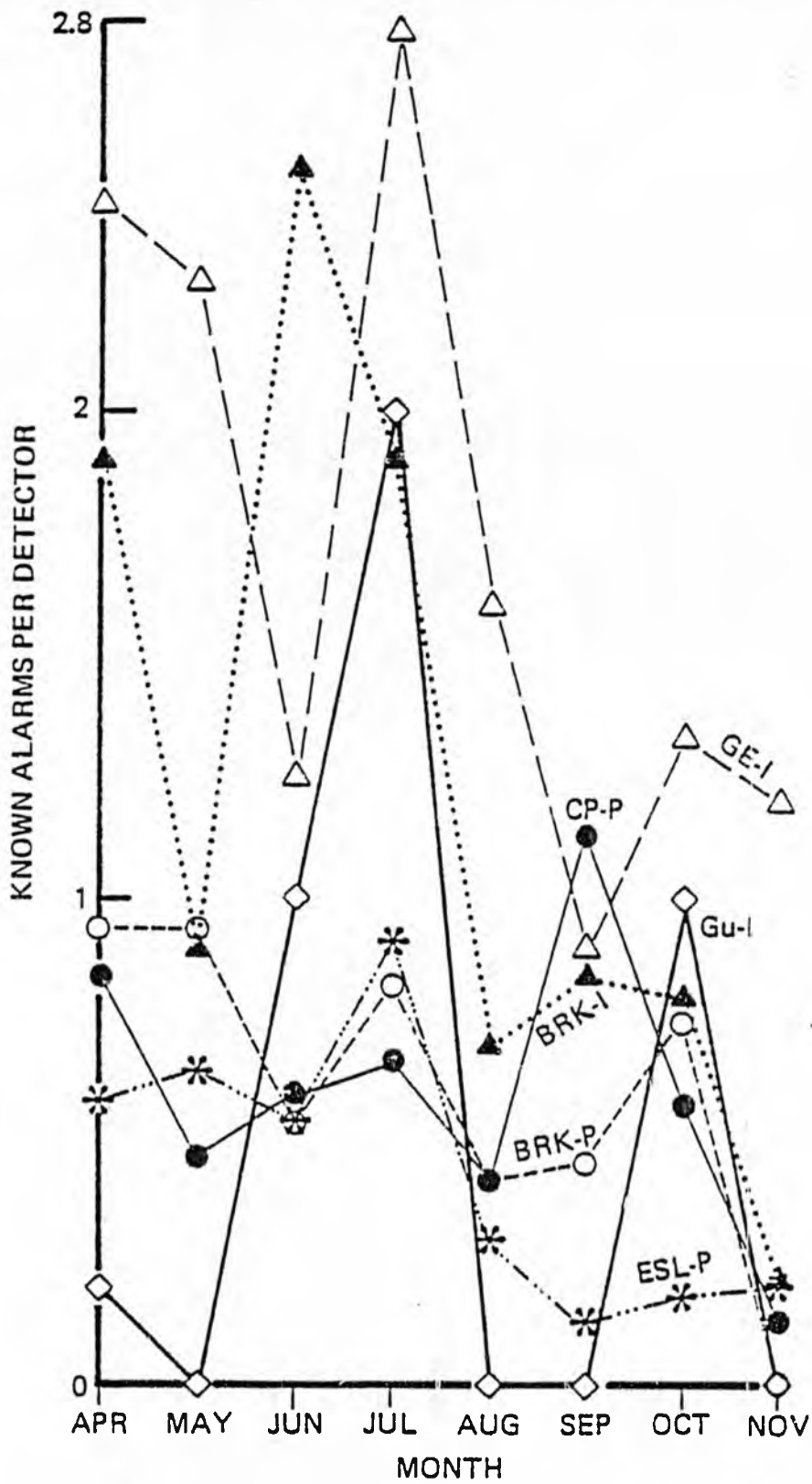

Figure 3a. Number of known alarms per detector per month for the various brands over the test period.

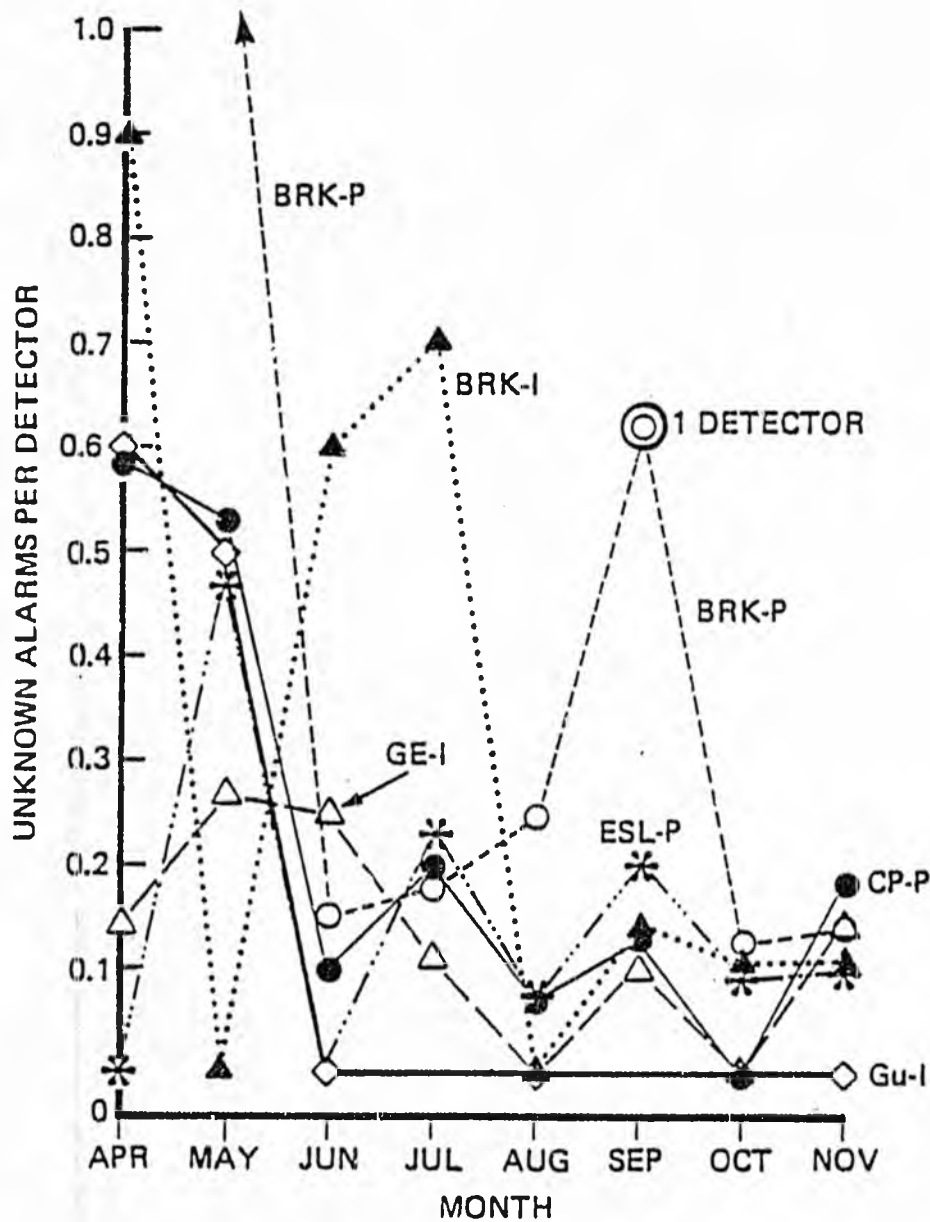

Figure 3b. Number of unknown alarms per detector per month for the various brands over the test period.

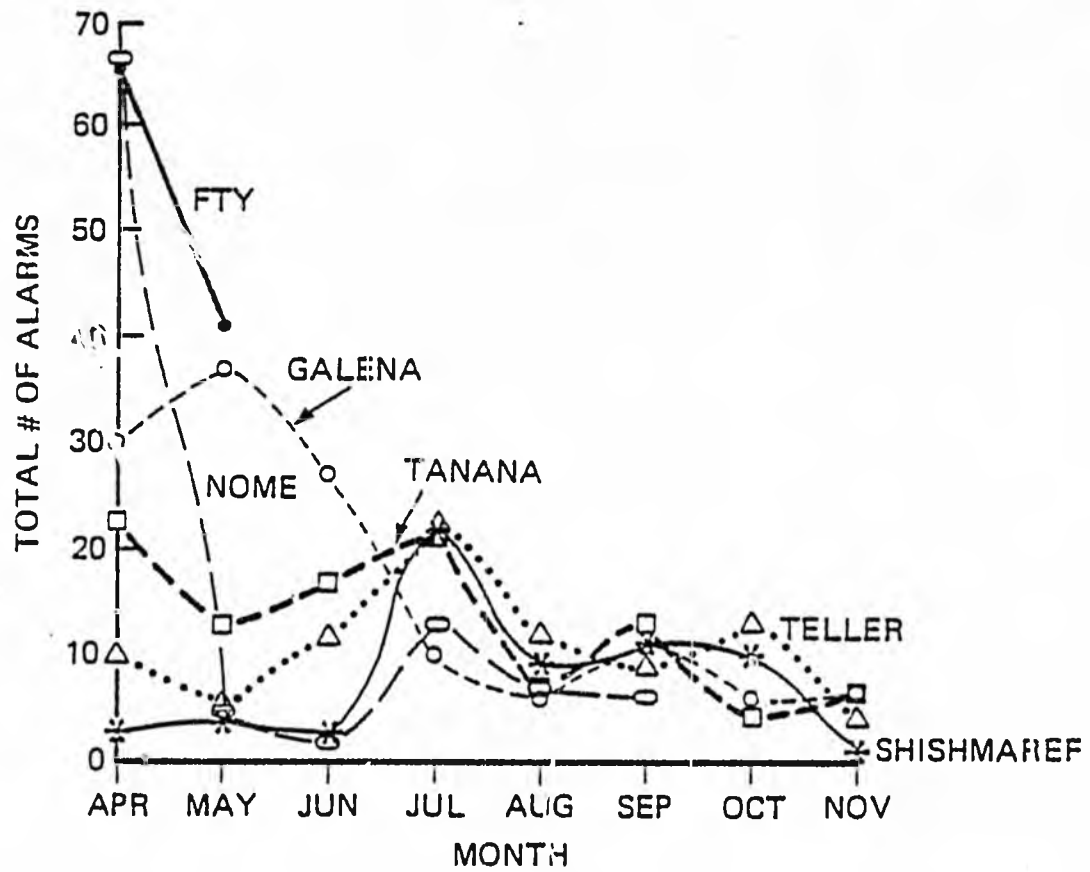

Figure 4. Total number of alarms per month at the different villages over the test period.

Figure 5. Types and Quantities of Alarms in Relation to Room Size

CAUSE	ROOM SIZE													TOTAL
	Small—<300 sq. ft.*						Large—>300 sq. ft.*							
	Ionization			Photoelectric			Ionization			Photoelectric				
	GE	G	BRK	BRK	ESL	CP	GE	G	BRK	BRK	ESL	CP		
Cooking	52	3	33	22	20	35	100	2	26	23	28	16	360	
Heating	oil	1	-	-	-	-	-	-	-	-	-	-	1	
	wood	8	1	3	4	-	7	3	-	-	3	1	31	
	both	-	-	2	2	-	5	-	-	1	-	-	11	
Other	1	-	-	3	1	12	2	-	5	5	3	3	38	
Unknown	5	2	13	42	5	19	8	-	5	20	6	9	134	

*The total number of houses was equally divided between these two measurements.

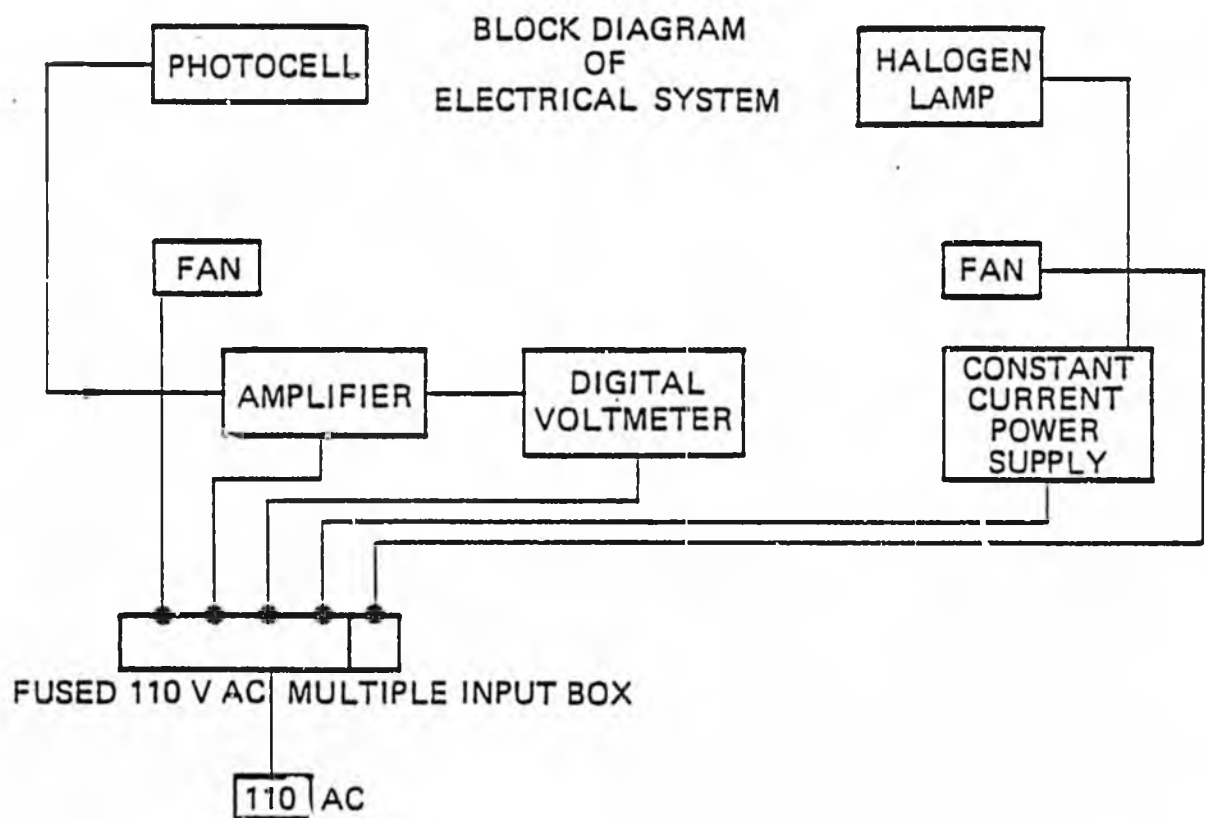
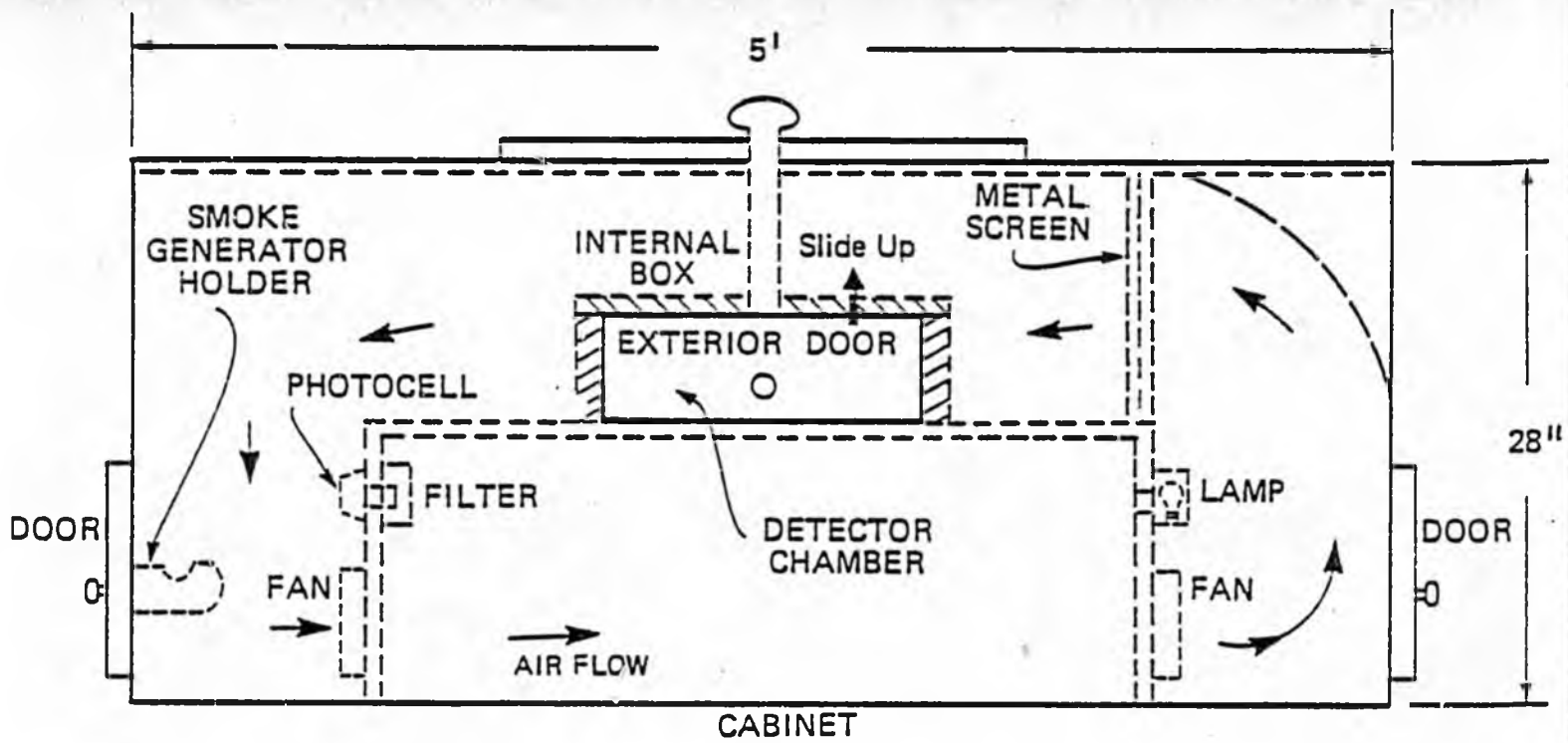

Figure 6. Basic diagram of the calibration smoke box and the electrical control circuit.

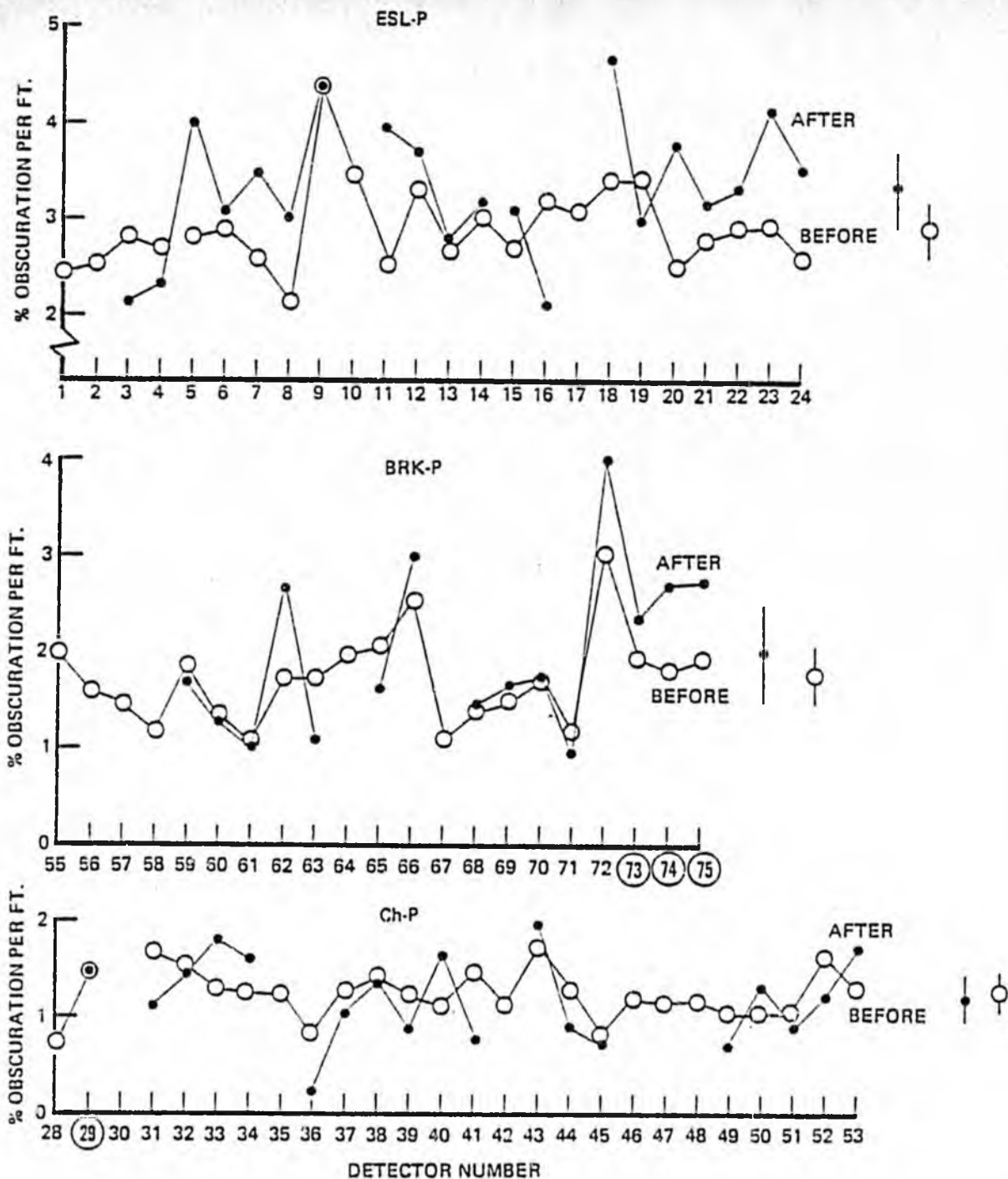

Figure 7a. Response of the photoelectric detectors to the level of smoke in the calibration smoke box before (O) installation in the villages and after (●) their return. The O and ● to the far right indicate the average response before and after for that group of detectors. The length of the vertical lines through these points represents the standard deviation of the group. The greater the percent obscuration per foot the greater the density of smoke in the box. The circled numbers are those detectors that remained in the lab as the control group.

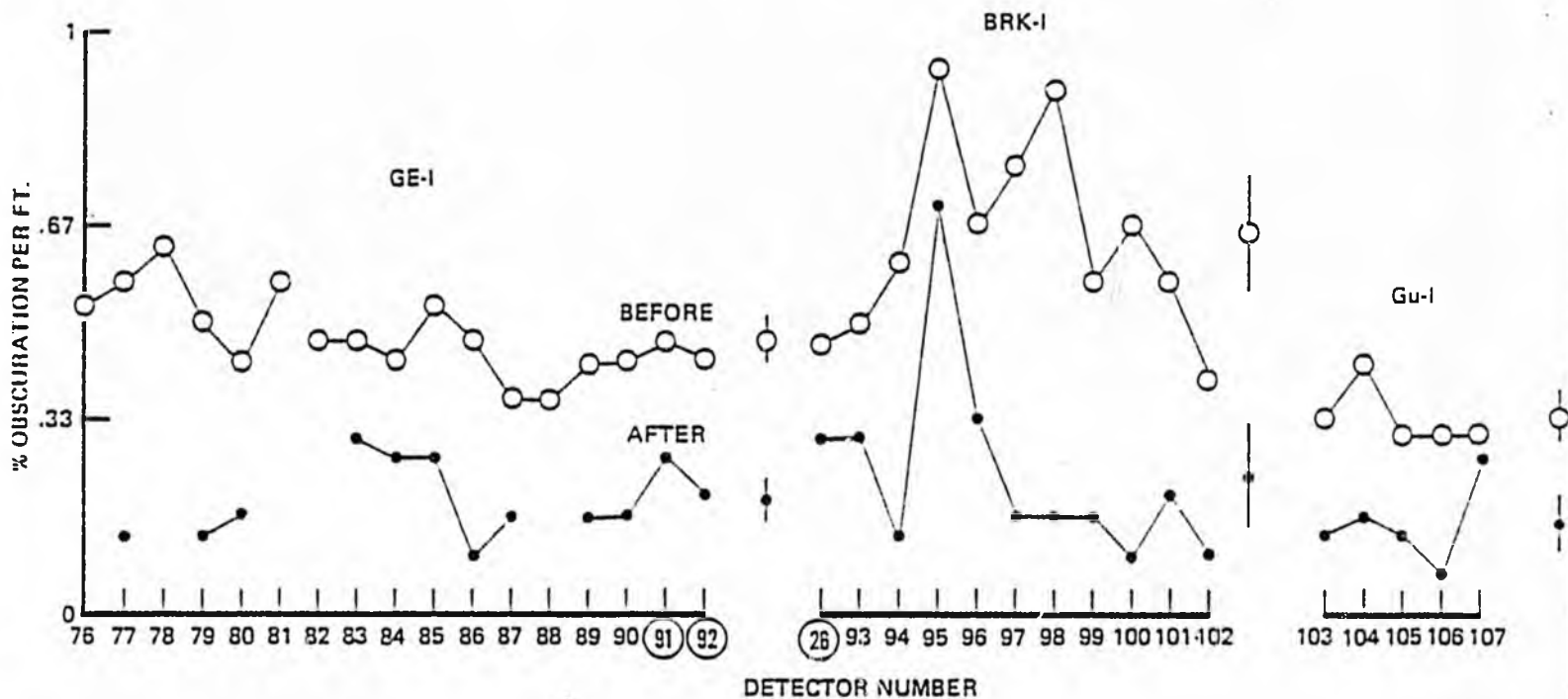

Figure 7b. Response of the ionization detectors to the level of smoke in the calibration smoke box before (○) installation in the villages and after (●) their return. The 0 and ● to the far right indicate the average response before and after for that group of detectors. The length of the vertical lines through these points represents the standard deviation of the group. The greater the percent obscuration per foot the greater the density of smoke in the box. The circled numbers are those detectors that remained in the lab as the control group.

**BACKGROUND INFORMATION FOR A RESEARCH PROGRAM ON
USE OF SMOKE DETECTORS IN RURAL ALASKA**

(Available on request: Alaska Council on Science and
Technology, Pouch CV, Juneau, AK 99811)

QUESTIONNAIRE

Village _____

Householder _____

Detector No. _____

1. Number of alarms:

No. single beeps _____ No. repeated beeps _____ No. continued buzzing _____

No. beeps not recorded _____

2. Unknown alarms:

Were they continuous or short beeps?

Possible cause(s).

3. Battery replacement:

No. changes _____

Due to repeated beeps every few seconds? If no, why changed?

4. Wire cut:

Yes or No _____ Why?

Any noticeable difference since cut?

5. Has the detector been acting differently since last month's report? How?

6. Attitude:

How do you feel about the usefulness of the detectors?

Do the false alarms reduce the effectiveness of them?

Would you want one in your house after the completion of the project?

Does the silencer make the detector better?

7. Comments:

Attitude:

Log keeping:

Dust:

VILLAGE COORDINATORS' INSTRUCTIONS

INTRODUCTION

The death rate due to residential fires in rural areas in Alaska is approximately five times higher than in urban areas, and the overall rate for Alaska is twice that of the rest of the nation. With these statistics in mind the Department of Public Safety is investigating the possibility of supplying smoke detectors to home owners in Alaskan villages and has determined that research on technical and social aspects of smoke detector use is necessary. The Alaska Council on Science and Technology was contracted by the Department of Public Safety to administer the research which will provide the information necessary to determine the effectiveness of smoke detectors in the unique conditions of Alaskan village homes.

Smoke detectors have been found to be a very effective means of saving lives by providing an early warning of fires. Two different kinds are made, ionization and photoelectric, which sense the smoke in different ways. Independent testing has found that photoelectric detectors respond quicker to smoldering fires (which are the cause of most residential fires), whereas ionization respond quicker to flaming fires.

In this project, primarily photoelectric detectors are being used because they have been found to be less subject to false alarms. The problem of false alarms is one of the major concerns of this testing because it is anticipated that the unique rural homes and lifestyles will cause more false alarms than would occur in other houses. This is due to the fact that: 1) houses are often smaller with one central living area, and 2) unusual amounts of smoke may be produced by the cooking and heating (and perhaps other) sources. The results of this testing will determine not only which kind of smoke detector is most effective in village conditions, but also where the detector should be placed within the home. The attachment of a device called a silencer, which enables the householder to turn off a false alarm for a short period of time, is also being tested on one detector in each house. Other modifications or unexpected results which will make the smoke detector more effective and also more acceptable to the villagers may be found.

In order to carry out this research a total of six villages in two regions (interior and coastal) have been chosen as test sites. Within each of those villages five homes will be selected to provide a cross-section of house constructions and life-styles. Three or four smoke detectors will then be placed in these homes, and the occupants will be asked to provide information about the smoke detectors, particularly the incidence of false alarms, for a period of six months.

ROLE OF VILLAGE COORDINATOR

To assist in all aspects of the testing in the villages, a resident of each village has been chosen to act as village coordinator. His or her role is vital to the success of the research. His advice and assistance will be crucial from the beginning of the program through the final evaluation at the end. Also, the village coordinator's understanding and positive attitude toward the usefulness of smoke detectors and this research program will have an influence on the homeowners' cooperation and enthusiasm in the project.

Specifically, the assistance of the village coordinator will be needed in the following areas:

1. Selection of houses. The proper selection of the houses is determined not only by the house construction, but equally importantly, by the attitudes of the occupants.
2. Placement of smoke detectors within the homes. Although the village coordinator will not be asked to actually select the location of the smoke detector in the homes

(this will be done by someone with experience in fire prevention from Fairbanks), his introduction to the householder and his presence during the installation process will be important in providing the link between the villagers and the project personnel. In some cases, the village coordinator might do the actual installation after the location of the smoke detector has been chosen.

3. Monthly visits. The village coordinator will be asked to visit each home once a month to collect the information log sheet, test the smoke detectors, answer questions, and generally evaluate the attitude of the people.
4. Final evaluation. The overall success of the program with respect to the activity of the smoke detectors and the attitude of the participants will be evaluated after six months.

To assist the village coordinators in recording his visits to the homes, two kinds of information logs will be provided.

1. The first will be filled out when the home is selected for the program.
2. The second kind will be filled out monthly to provide the findings of each visit.
3. In addition, the village coordinator will collect the logs which the householder himself has filled out during the month.

When these logs are completed, they will either be sent directly to the central project office in Fairbanks or picked up by a representative of the central office. The procedure for filling out the forms will be discussed later.

PAYMENT

Both the homeowners and the village coordinators will be paid for their cooperation in this program. The village coordinator will be paid a total of \$240 in six installments. \$40 will be paid at the beginning of the program, and a \$40 payment will be made each month after receipt of the logs by the central project office.

Each homeowner will be paid a total of \$150. \$50 will be paid when the smoke detectors are installed; payments of \$10 will be made after each monthly log is picked up; another payment of \$50 will be made at the end of six months. In addition, both the homeowners and the village coordinators will be given one of the smoke detectors to keep (after it has been given its final checkup).

LOGS

House Selection Characteristics

The form entitled House Selection Characteristics has been provided to record the choice of houses to be used in the testing. It is suggested that the village coordinator tentatively choose approximately 10 homes which he thinks meet the criteria for both house construction and homeowner attitude. At the time of the visit by the central project person, the five final houses can be determined together. The type of house being used in the testing is typically a log or frame one-room, low-ceiling building approximately 400-600 square feet with poor ventilation. Bedrooms are attached to the large living area, separated by a drape or a door. The cooking is done

on a gas, oil or wood range, and the heating systems are usually wood- or oil-burning stoves. Other types of houses can be used in the testing, but the emphasis should be on using houses which present conditions unique to rural Alaskan which would not be found elsewhere.

The items on the House Selection Characteristics form will be discussed in order to assist in the selection process.

1. Homeowner/address. Identification of house by owner and, if necessary, address.
2. Construction. In villages where there is a variety of construction, this mixture should be reflected in the choice of test houses. This could include log or frame houses or a combination of styles. However, some villages will have homes of only one basic type of construction, in which case a variety is neither possible nor desirable in choosing a representative sample.
3. Ceiling
 - a. Flat or sloped. Since smoke travels differently across flat or sloped ceilings, both types of houses should be tested. If it is sloped, an estimation of the gradient should be made as: slight, gradual, steep.

Beams are a special consideration for several reasons. Although we do not want to completely eliminate houses with beams, it is important to pay particular attention to homes which have them. If the beams extend more than about eight inches down from the ceiling, they could block the smoke from reaching the smoke detector. Also, if the beams are placed closer together than three feet, there will not be enough room to place the board with the smoke detectors. It might be possible to place the board either along the beam itself or across the beams if this seems to be the best location for a smoke detector under actual living conditions.
 - b. Height. In the case of a sloped ceiling, the height at the lowest and highest points should be measured if possible.
6. Heat source.
 - a. Oil. Because of the different forms of combustion used in gravity-fed or gun-fired oil furnaces, both kinds should be tested if possible.
 - b. Again, if several forms of heating are used in the village, a representative sample is desirable.
7. Cooking source. A representative sample of cooking methods in the village is preferred.
8. Lighting source. If the source of light produces smoke, this could affect the detectors.
9. Smoke detector placement. The distance from which the smoke detector is placed in relation to these objects will help us determine the cause of false alarms.

10. Family

- a. Number of occupants. The activities of different sized families and the amount of smoke produced may influence the occurrence of false alarms. Therefore, families of different sizes are required.
- b. Ages. For the same reasons, families of different ages are necessary.
- c. Scheduled absences. Absences of the family from the house are important to record for several reasons. If the family plans to be away for a large portion of the test period (more than six weeks), then the records may not be complete enough to be useful. On the other hand, shorter absences could be useful in the test since the life of the battery could be shortened if allowed to freeze, and false alarms might result. Therefore, it is necessary to know whether the house is heated during the absences. Both scheduled and unscheduled absences should be recorded during the monthly visits by the village coordinator.
- d. Attitude. The attitude of the family is difficult to record objectively and scientifically because it is more a matter of sensing their feelings, rather than asking direct questions. However, a brief statement about their attitude on this initial form will allow for some comparisons in follow-up visits. If the interest of the householder is too low at the beginning or drops significantly during the testing period, it is possible that he will be taken out if the village coordinator thinks that his attitude is influencing the record-keeping.

The attitude of *all* the family members is important to evaluate if possible because each person could play a role in producing and recording false alarms. A negative attitude of an individual member would be more harmful to the testing than a lack of interest if it took the form of deliberately altering the results in any way.

Some of the specific aspects to look for in choosing a family and determining their attitude toward the testing would be to find out how they feel about: 1) having a 2-to 3-foot board placed on their ceiling for six months and a log sheet on their wall; 2) having people (both known and unknown) come into their home to install the smoke detectors and then check up on them; 3) keeping a careful log of false alarms; 4) the possible occurrence of frequent false alarms.

- e. Education. The education level of the family members is important insofar as it relates to their understanding of this project. If there is little or no understanding of the purpose or procedures of the testing, the results cannot be considered to be reliable. As with evaluating their attitude, their education level would be determined not by direct questions, but rather by background knowledge of the village coordinator or general questions.
11. The main activity of the family in the room where the smoke detector is located will help determine the cause of false alarms as well as the probable frequency. An estimation of how much smoking is done in this room would be useful, too.
 12. Floor plan. As accurate a floor plan as possible will help to determine the cause of false alarms as well as give a visual picture of the house and relative placement of the smoke detector.

Monthly Visit

The monthly visits which will be done by the village coordinator will have several purposes: 1) to collect the householder's log and leave another, 2) to test the smoke detector, 3) to evaluate the attitude of the family, 4) to provide on-going explanations and encouragement on the project. A log sheet will be used by the village coordinator to record his findings and will be sent monthly to the central project office.

This Monthly Visit log will provide the following information:

1. The house, date visited, and smoke detector numbers.
2. Testing results. The village coordinator will actually test the operation of each detector and record whether it is OK or Not OK. If some unusual action is necessary, it should be recorded and described with as much detail as possible as to the nature of the problem, cause, action taken, recommendations. If a detector alarm does not sound during testing, the battery should be replaced, and then the detector left in place whether it works or not.
3. Absences. It will be necessary to inquire about absences during the month in order to determine whether the battery of the smoke detector may have been frozen, and if so, for how long.
4. Attitude of family. General observations and particularly changes in the attitude of the family should be noted here. Other observations which can be indicated might include such things as: whether one family member is particularly enthusiastic or the opposite, whether all the members seem to be cooperating or only one or two; general observations and recommendations.

It is anticipated that some smoke detectors will be removed by the researchers for one reason or another. This could be due to factors such as the family moving or requesting the removal because of too many false alarms. However, sometimes the village coordinator himself will have to make the recommendation to remove the smoke detectors with the approval of the central project office. If the annoyance of false alarms becomes too great or the attitude of the family deteriorates for any reason to the point that the test results will be unfairly influenced, the smoke detectors should be removed. If the family does not seem to be cooperating within the first two months of the project, the smoke detectors will be removed and placed in another house. In the case of unwanted false alarms, it may be possible to remove the battery from the most annoying detector and continue the experiment with the others. In any case, the judgment of the village coordinator will be very important in detecting the changing attitudes as well as making recommendations.

It is also possible that the village coordinator will be unable to pick up the Householder's Log for one reason or another. If the family has lost their log or forgotten to fill it out, the village coordinator can question them about the activity of the smoke detectors during the past month to try to get as much information as possible. However, if good records cannot be obtained from the householder for two months in a row, the family may be removed from the project. It is possible that the family will be away at the time of the monthly visit in which case the village coordinator should fill out his regular report within one week indicating that they were not there. He will then get the Householder's Log as soon as possible and carry out his regular monthly test and interview at that time. No doubt other unforeseen situations will arise which will have to be dealt with by the village coordinator together with the central project office.

Householder's Log

The householder will be given a packet which will contain his logs with brief instructions and background information about this project and smoke detectors. The family should be able to fill out this form with no assistance from the village coordinator. This log is used primarily to record the frequency and cause of false alarms, as well as the action taken to stop the alarm. In addition, certain items have been included to help evaluate the interest of the family in the smoke detectors themselves. These items are: 1) the name of the person recording the information, and 2) how often the detector is tested. The family is also encouraged to write their comments about the detectors and the project on the log.

CONCLUSION

In conclusion, we would like to emphasize again the key role of the village coordinators in the overall success of this test project. The village coordinators' interest, enthusiasm and motivation are important not only in the work which they themselves do, but also in the influence which they will have on the participation of the families. The thoroughness and carefulness with which the coordinators complete the forms may also be reflected in the care taken by the families.

It is hoped that the village coordinators view the long-range goal of providing smoke detectors for all the homes in the villages as a valuable life-saving means, and in addition, that they understand the immediate benefits of making the people more aware of the danger of fire and its detection and prevention.

HOUSEHOLDER INSTRUCTIONS

INTRODUCTION

Loss of life and property by fires in homes is much higher in Alaskan villages than in the rest of the State. For that reason the Department of Public Safety will be offering smoke detectors at a low cost to village residents. Smoke detectors have been found to be essential in warning people of fires in their homes giving them time to escape. There are two kinds and many brands of smoke detectors made. Ionization detectors have been used in most homes in the past. However, a newer kind called photoelectric may be better suited for village conditions.

The houses and lifestyles of village residents are quite different than the rest of the United States. Some of these differences, such as small one-room houses and wood-burning stoves, can cause problems for smoke detectors. The detectors are made to "smell" or "see" smoke and then sound an alarm to warn the inhabitants. However, the smoke detectors do not know the difference between "friendly" smoke, such as from a wood-burning stove, and "unfriendly" smoke, such as from a smoldering mattress. Because there is likely to be more "friendly" smoke in village homes than others, false alarms could be a great problem. It is to test the frequency and cause of these false alarms that this research is being done.

You are one of several families in 6 villages in Alaska we have asked to put 3 smoke detectors in their homes. The smoke detectors will be left in your home for 6 months during which time you will record on a chart what the detectors do. A person in your village, the village coordinator, will collect these charts from you once a month to send to Fairbanks. You will be paid \$50 at the beginning of the project and \$10 more at the end of every month. At the end of the entire project you will be paid \$50 more to total \$150 in all.

HOUSEHOLDER'S LOG

This chart (or log) will be used for you to record what happens each time an alarm goes off. All of these answers will help determine which smoke detector is best to use in the villages. Therefore, *it is very important to record each alarm carefully and completely.* The chart is to be filled out each time an alarm goes off in the following way

1. Detector Number/Color. Each time an alarm goes off, write the number or color of the detector which is sounding.
2. Date. Write the day's date.
3. Time. Write the approximate time the alarm goes off.
4. Name. Write the name of the person recording the information.
5. FALSE ALARM CAUSE. False alarms can be caused by many things, so it may not always be possible for you to know exactly. Some of the possible causes could be smoke and fumes from the following sources:

Cooking—fumes from cooking can cause false alarms whether you can see smoke or not.

Heating—Wood-burning stoves: when the fire is started or the door is opened to add wood smoke may escape.

Oil-burning stoves: malfunction of controls may cause smoke.

Lighting—the smoke from oil- or kerosene-burning lamps.

Smoking—smoke from many cigarettes.

Unknown—If you don't know what caused the alarm, put an X here.

Other—If you know the cause and it is not one of the boxes on the chart, write in what you think caused the alarm.

6. ACTION TO STOP ALARM. Several actions can be taken to stop the alarm.

Nothing—Put an X here if the alarm stops without your doing anything.

Pushed Button—Put an X here if you push the silencer button. If the alarm comes on again, write down another false alarm.

Fanned Air—Sometimes fanning the smoke away from the detector will stop it.

Removed & Replaced Battery—The battery can be removed to stop the alarm, but it should be replaced as soon as possible. Do not remove the battery permanently without telling your village coordinator.

7. Tested. You may want to test your smoke detector by pushing the test button on the detector itself. This will tell you whether it is working or not. Write down when you do it.
8. Comments. If you have any comments about the smoke detectors or the program in general, write them down here.

PROBLEMS

Several problems could occur over the 6-month period. False alarms could become very bothersome. If you find that one or more of the detectors is particularly annoying, tell your village coordinator. He or she will then take some action. It is *very important* to record anything done by or to the smoke detectors so we can know how the detectors are acting. For instance, one of them may stop working. This could be due to several factors and your village coordinator will know what to do. A detector could start sounding at regular intervals for no obvious reason. This could be because the battery is low. Tell your village coordinator and he or she will replace the battery. Another problem could be misplacing the chart. If that happens, start another one but try to record all the false alarms you can remember from the lost chart. The village coordinator has extra charts and will bring you new ones every month. If you plan to be away from your home for more than 2 weeks, tell your village coordinator. If you have any questions or problems, talk to your village coordinator or call us collect at 479-7010.

As you can see, you are the most important person in this project. You are the one who hears the alarm. You are the one who writes down what happens every time. And you are also the one who may be bothered by false alarms. But with your cooperation, a smoke detector will be found which may save your life as well as your neighbors.

Interviewer

MONTHLY VISIT

Homeowner:

Date:

1. Detector number/color:
Test results: (OK, Not OK)
Action taken:

2. Detector number/color:
Test results: (OK, Not OK)
Action taken:

3. Detector number/color:
Test results: (OK, Not OK)
Action taken:

Absences:

Dates

Detectors Frozen (Yes, No, Don't Know)

Attitude of family:

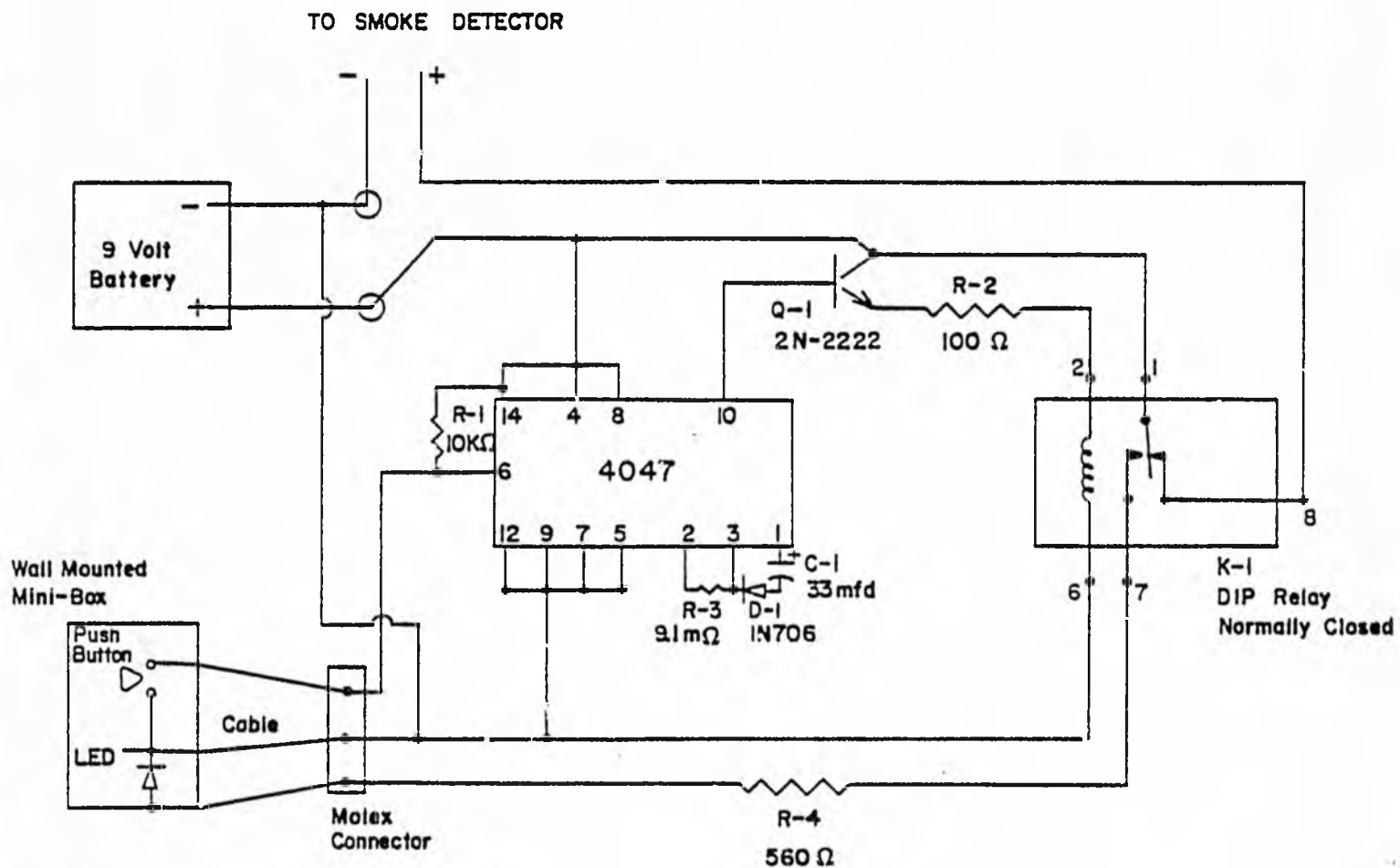

Silencer circuit installed in the smoke detectors prior to their installation in the villages.



F

THE ALASKA COUNCIL ON SCIENCE AND TECHNOLOGY

SYNOPSIS OF GRANTS

For the Alaska Council on Science and Technology

Northern Technology Grants Program

1979 through 1982

April, 1982

Northern Technology Grants Program

The Northern Technology Grants Program began when the Alaska state government appropriated funds in July, 1979. These funds were to be awarded by ACST in grants up to \$5000 to Alaskans with innovative ideas in northern technology.

The initial program was so successful that in 1980, 1981 and 1982 additional grant funds were awarded to ACST to conduct three more Northern Technology programs.

The program has awarded grants to projects that are low-cost alternatives for Alaskans in such areas as building design, food production, recycling, transportation, energy generation and waste disposal. The immediate benefit of the grant is to the person with the idea but the long-range benefit will be to all Alaskans. Grant recipients are required to provide a progress report to the ACST and in many cases, recipients conduct demonstration workshops on project results for community members or other interested Alaskans. Also, the Alaska Council on Science and Technology publishes "Technical Briefs" on the successful projects. These short "how to" reports are intended to show others in the state how grant recipients completed their projects while also describing pertinent results.

This is a list of all 113 Northern Technology awardees and synopses of the projects. For more information concerning the program contact: Alaska Council on Science and Technology; Pouch CV; Juneau, Alaska 99811 or telephone (907) 465-3510.



TABLE OF CONTENTS

1979 GRANTS.....	1
Regenerative Freezer (0011).....	1
Juice Bottling Plant (0107).....	1
Hydraulic-powered Auto (0146).....	1
Bee-overwintering Building (0083).....	2
Waste-heat-claiming Greenhouse (0029).....	2
Solar Hot Water Heater (0089).....	2
Insulated Shutters (0144).....	2
Tidal/Current Hydraulic Suction Dredge.....	3
Solar Greenhouse (0139).....	3
Oil Fired Clothes Dryer (0145).....	3
Methyl-fuel Plant (0165).....	4
Hydroelectric Generator (0155).....	4
Wood Furnace (0136).....	4
Electric Car (0098).....	4
Solar Greenhouse (0074).....	5
Ambulance Splint (0027).....	5
Hydroelectric Generator (0129).....	5
Solar Heater (0065).....	5
Waste-Oil Heater (0106).....	6
Experimental Greenhouses (0180).....	6
1980 GRANTS.....	7
Induction Generator (0506-80D).....	7
Solar Space Heater (0226-80).....	7
Furnace Conversion.....	7
Treatment Unit (0312-80).....	7
Battery or Fuel Cell Made From Scrap Metal (0508-80D).....	7
Window Insulation (0036-80).....	8
Dog, Water or Wind Powered Washing Machine (0358-80 & 0359-80)....	8
Greenhouse (0515-80D).....	8
Wind Generator (0098-80).....	8
Waterproofing for Earth Shelter House (0165-80).....	9
Greenhouse (0055-80).....	9
Trailer Steering Device (0081-80).....	9
Recycling Aluminum Scrap (0085-80).....	9
Generator (0332-80).....	9
Solar Heat House (0072-80).....	10
Boiler System (0155-80).....	10
Solar Wood Drying Kiln (0116-80).....	10
Wind Generator (0540-80D).....	10
Digester (0045-80).....	11
Improved Willow Rake (0374-80).....	11
Fruit and Nut Tree Cultivation (0298-80).....	11
Permafrost Excavation (0232-80).....	11
Hybrid Electric Car (0281-80).....	11
Plant Hydro Feed System (0290-80).....	12
Passive Solar Home Plans (0159-80).....	12
Shutters for Greenhouse (0327-80).....	12
Subterranean Outbuildings (0130-80).....	12
Solar Thawing of Permafrost (0044-80).....	12

1980 GRANTS (Continued)

Effective U-Value Measurements (0139-80).....13
Arctic Home Construction (0505-80D).....13
Solar Greenhouse (0328-80).....13
Home Energy System (0118-80).....13
Methane Generator (0362-80).....13
Automated Thermal Shutters (0309-80).....14
Technique for Shallow Subsurface Exploration (0020-80).....14
Generating System (0538-80D).....14
Data Recording Instrument (0205-80).....14
Solar Energy Heating System (0064-80).....14
Solar Wood Drying Kiln (0248-80).....15
Water Heating (0177-80).....15
Fish Drying Process (0145-80).....15
Steam Plant for Small Boat (0262-80).....15
1 Watt Translator (0166-80).....16
Home Energy Conservation System (0234-80).....16

1981 GRANTS.....17
Development of Clam Harvesting Technique (063-81).....17
Development of a Cam Operated Arctic Door Design (061-81).....17
To Grow Fruit Trees in the Yukon-Tanana Uplands (115-81).....17
To Convert a VW Bug to a Hybrid-Electric Vehicle (110-81).....17
To Use Spill-Over Energy From a Hydraulic Windmill (117-81).....18
Equipment for Sensitivity and Cold Temperature Testing of
Smoke Detectors (131-81).....18
Heat Pump for Foundation Stabilization (118-81).....18
To Install a High-Pressure Jet Modification to a Clam
Harvester (066-81).....18
Device to Test Soil Strength (061-81).....19
To Develop a Submersible Investigating Drone (069-81).....19
To Study the Feasibility of Migratory Bee/Honey Operation
Sympathetic to Delta Barley Project (070-81).....19
Wind Powered Heat Pump and Lighting System (003-81).....19
Mariculture of Subtidal Red Seaweeds (005-81).....20
To Construct a Dual-Layer Greenhouse on Alaskan
Peninsula (020-81).....20
To Refine Indoor Hydroponic System (022-81).....20
To Develop a Method of Producing Ethanol Alcohol (026-81).....20
High Temperature Surface Combustion Techniques (028-81).....20
To Construct a Chicken House and Solar Pit Greenhouse (031-81).....21
Composting Techniques Experimentation (033-81).....21
To Reuse Waste Heat from Laundromat (038-81).....21
To Construct a Solar Semi-Subterranean Barn/Root Cellar (052-81).....21
Construction of Electric Hybrid Car (057-81).....22
Improved Hydraulic Ram for Use on Streams in Interior
Alaska (056-81).....22
Wood Fueled Electricity Generator (059-81).....22
To Develop a Micro High Head Hydroelectric Site for Reduction
of Fossil Fuels (077-81).....22
To Reuse Waste Computer Paper.....22
Emergency Solar Power for Small Boats (004-81).....23
To Recycle Aluminum Cans (013-81).....23
River-Powered Electrical Generator (021-81).....23
Installation of Self-Timer Silencers on Smoke Detectors (130-81).....23
To Dive to Record Abundance and Distribution of Seaweeds(006-81).....24

1982 GRANTS.....	25
Wood Utilization Survey in the Fairbanks North Star Borough (N-82-01).....	25
Development of an Automatic and Manual Fuel-Saving Floor Register (N-82-02).....	25
Frozen Food Processing Plant (N-82-14).....	25
Documentation of Off-Peak Electric Heating Systems and Usage (N-82-23).....	26
Design, Development and Test Manual, Semi-Automatic and Automatic Controls for Thermal Shutters (N-82-26).....	26
Design and Construct Waste Oil Furnace (N-82-44).....	26
To Develop a Microprocessor Controller to Optimize Hot Water Heater Usage (N-82-49).....	27
Bandsaw Power Alternative for Bush Areas (N-82-51).....	27
Cross-Transmission of Coccidiosis between Wild and Domestic Alaskan Sheep (N-82-72).....	27
Studio-Sized, Hydraulically Powered Impact Mill (N-82-77).....	28
Soil Heated Food Production With Seep Irrigation (N-82-87).....	28
Winter Storage for Root Crops (N-82-103).....	28
Development of a Low-Cost, Lightweight, Solar Snow Melter for Expeditionary and Remote Site Use (N-82-107).....	28
To Develop a Hydro-Power Generation System (N-82-109).....	29
Monitoring of Interior Window Insulations (N-82-80).....	29
Instrumentation for a Small Hydro-Power Project (N-82-108).....	29
Fish Meal and Oil Producing Raft (N-82-119).....	29
Hydrogen Gas Generation by and for Boats (N-82-38).....	30

ALPHABETICAL CROSS REFERENCE
1979-1982 GRANTS

Abegg, Frank III (N-82-44).....	26
Alakanuk City Council (0506-80D).....	7
Alaska Altern. Energy Resources Ct (0226-80).....	7
Alaska Federation for Community Self-Reliance (0327-80)....	12
Albert, Phillip (0130-80).....	12
Bailey, Don (0008-80).....	7
Bair, Norman (0312-80).....	7
Balch, Joseph (0044-80).....	12
Barger, James (0029).....	2
Beaudoin, Douglas (068-81).....	19
Benevento, John (131-81).....	18
Berson, Thomas R (0508-80D).....	7
Bingham, Bert (0146).....	1
Black, Joseph Charles (N-82-38).....	30
Brown, Pete (021-81).....	23
Butera, Louis (N-82-108).....	29
Calvin, Natasha (005-81).....	20
Carlson, Paul (070-81).....	19
Carney, Steve (0027).....	5
Carlson, Axel R (0139-80).....	13
Cassell, Kenneth (077-81).....	22
Cloyd, Bobby (0505-80D).....	13
Corbridge, Clark (117-81).....	18
Coutts, H. J. (057-81).....	22
Crawford, Michael (0328-80).....	13
Cunningham, Jim (0036-80).....	8
Davies, John (N-82-26).....	26
DeBoard, Carl (063-81).....	17
Delbridge, Craig (026-81).....	20
Detzel, Jack Jr. (052-81).....	21
Dillon, John (0118-80).....	13
Donally, Jim (0180).....	6
Doner, Alfred (0155-80).....	10
Ellis, Robert (006-81).....	24
Ford, Richard (0155).....	4
Forster, Bruce (0116-80).....	10
Friedman, Bonnie (115-81).....	17
Gerow, Eugene (033-81).....	21
Grimm, Douglas (0165).....	4
Grove, David (0098).....	4
Guthrie, R. Dale (118-81).....	18
Gurtler, Stanford (N-82-103).....	28
Hall, Bill (0358-80 & 0359-80).....	8
Hart, K. Quinn (0515-80D).....	8
Hicks, Steve (0098-80).....	8
Hightower, William (0540-80D).....	10
Hoke, O. Alexander (0162).....	3

Hornberger, Charles & Sara (020-81)	20
Isaacs, Marnie & John (0165-80)	9
Jablonowski, Richard (N-82-49)	27
Johansen, Chris (0065)	5
Johnson, Edward (0045-80)	11
Jones, Cecil R. (0374-80)	11
Kirchhoff, Matthew (N-82-51)	27
Klein, Ronald (0262-80)	15
Knoebel, Ed (0055-80)	9
Lamb, Chris (0362-80)	13
Laroe, Steve (N-82-01)	25
Leis, Karen (0298-80)	11
Loeffler, Michael (N-82-109)	29
Matheson, Alex (0081-80)	9
McDonald, William (N-82-80)	29
McDougall, Kevin (0011)	1
McGrath, Ed (0309-80)	14
McHattie, Robert (0020-80)	14
Miller, Richard (059-81)	22
Moen, Daniel (013-81)	23
Molvik, David (0166-80)	16
Moor, Jay (0234-80)	16
Neville, Ted (0129)	5
Newell, W. Charles (110-81)	17
Nielson, Carol (N-82-72)	27
North, Nancy (079-81)	22
Olanna, George (004-81)	23
Olson, Erick (003-81)	19
Orth, Joy (031-81)	21
Pelz, Carl (0538-80D)	14
Pendergrast, Donald (0106)	6
Phillips, John (0085-80)	9
Posciri, Charles (0232-80)	11
Potter, Mike (0145)	3
Quirk, John (N-82-87)	28
Quiroz, Ricardo (0281-80)	11
Radio Communications Inc. (0332-80)	9
Raymond, James (0205-80)	14
Reinhart, Robert (0072-80)	10
Riche, N. Meade (056-81)	22
Rowcroft, Michael (0107)	1
Ruef, Donald (0136)	4
Sanders, Phillip W (061-81)	17
Scott, Julie (0089)	2
Seifert, Richard (0064-80)	14
Shadura, Elizaveta (0290-80)	12
Shaw, Albert (N-82-23)	26
Simmons, Charles (0248-80)	15
Simmons, Horace (028-81)	20
Smiley, Steven B (159-80)	12
Smith, Randy and Larry (069-81)	19
Smoyer, Nancy (130-81)	23

Stam, John (N-82-119).....	29
Stannard, David (N-82-77).....	28
Stark, Max (N-82-14).....	25
Stoops, David (0083).....	2
Stoppenbrink, Norm (0180).....	6
Stultz, Ed (066-81).....	18
Sturm, Matthew (N-82-107).....	28
Tack, Cyndie & Stephen (0139).....	3
Viereck, Leslie A (0177-80).....	15
Wagner, Dane (N-82-01).....	25
Walton, Robert (0144).....	2
Weld, Jeremy & Linda (0074).....	5
Wik, Ole (0145-80).....	15
Wilcox, James (038-81).....	21
Winograd, Ira (022-81).....	20

REGENERATIVE FREEZER (0011)

Kevin McDougall
P. O. Box 503
Delta, Alaska 99737

Amount Funded: \$3,100

Awardee will build a multi-family freezer which will store the winter's cold for summer use. It will maintain freezing temperatures for 3,000 pounds of meat or fish year-round without need of any power source whatsoever. The freezer will be a buried 14' x 14' room housing a 10 foot high, 10 foot diameter brine-filled tank. A fluid-filled convection loop will be installed in the tank and a project above ground. When the outside air is colder than the brine, the convection loop will continuously remove heat from the freezer and dissipate it above ground. The freezer will be insulated well enough to keep heat out during the summer.

JUICE BOTTLING PLANT (0107)

M. Michael Rowcroft
c/o St. Judes Center
3272 Hospital Drive
Juneau, Alaska 99801

Amount Funded: \$3,250

Awardee will set up a juice processing, bottling and distributing center in Juneau. Overripe produce purchased from local markets and wholesale distributors will be processed, bottled in recycleable containers and sold to the public at reasonable cost. All processing will be performed according to the State Division of Public Health regulations -- Mr. Rowcroft is the Juneau District Sanitarian.

HYDRAULIC-POWERED AUTO (0146)

Bert Bingham
1650 Beaver Road
Fairbanks, AK 99701
(Ken Kunkel)
(Don Luterbach)
456-2491
452-2718 (message)

Amount Funded: \$4,045

This grant will help finance the building of an automobile with a hydraulic propulsion system. A volkswagen chassis and running gear with a sleek fiberglass body will house the low-fuel/high-energy system. The system starts with a 16 h.p. Briggs and Stratton engine. This drives a hydraulic pump. The hydraulic pump supplies charge pressure to two 5000 psi accumulators, and drive pressure to a Sunstrand hydraulic motor. The small gas engine operates at full power until the accumulators are fully charged. At that point the engine drops back to idle and the accumulator takes over. The sequence repeats automatically when the accumulators are drained to a certain level. The propulsion system, which has been previously demonstrated elsewhere, is expected to develop 75 mpg while cruising at 55 mph to 75 mph.

BEE-OVERWINTERING BUILDING (0083)

David Stoops
Mile 2.3 Kalifonsky Loop
S.R. 2, Box 707
Kasilof, Alaska 99610
Phone: 252-4904 or 262-7212
262-4904 or
262-7212

Amount Funded: \$3,775

The awardee will construct a building in which he will over-winter bees in a controlled environment. Presently, the state's 250 beekeepers have no alternative but to kill their bees each fall and face the difficulty and expense of shipping in new bees each spring.

WASTE-HEAT-CLAIMING GREENHOUSE (0029)

James Barger
Galena Regional Learning Ctr.
P. O. Box 181
Galena, Alaska 99741

Amount Funded: \$2,570

GRLC is a rural extension of the University of Alaska involved in facilitating subsistence gardening programs in 17 villages along the Yukon and Koyukuk Rivers. The group will use grant money to build a 1,500 square foot greenhouse heated by waste heat from the local power plant. The Galena Air Force Site will provide access to the glycol solution in the plant's cooling system. The hot glycol will be piped to a unit heater inside the greenhouse as well as through the soil bed of a garden behind the power plant.

SOLAR HOT WATER HEATER (0089)

Julie Scott
Camp Property Committee
c/o Box 80435
College, Alaska 99708

Amount Funded: \$1,200

Camp Bingle-Harding Lake Camp is a non-profit camp operating at Harding Lake, a recreational area 40 miles east of Fairbanks. The camp is used by various children's groups and its program is educational in nature. The staff will build a solar collector into the camp's hot water system to help offset operating expenses and incorporate energy awareness into the camp's educational program.

INSULATED SHUTTERS (0144)

Robert Walton
P. O. Box 1480
Fairbanks, Alaska 99701
Phone: 479-6838
479-6838

Amount Funded: \$1,100

The awardee will design and construct insulating shutters that can be used to cover large window areas to reduce heat loss. The shutters will take advantage of garage door technology and photoelectric or temperature sensing switches to achieve ease of operation.

TIDAL/CURRENT HYDRAULIC SUCTION DREDGE (0162)

O. Alexander Hoke
P.O. Box 963
Juneau, AK 99802
Phone: 789-0065
789-0065

Amount Funded: \$5,000

Awardee will design and develop a working model of a tidal/current hydraulic suction dredge. A tide or current powered low velocity hydraulic turbine will drive a centrifugal water pump after the high-torque, low-RPM turbine energy has been translated into low-torque, high-RPM energy by a water tight gear box. The high-velocity discharge of water will be injected through a reduction nozzle and create a vacuum at the suction head. This vacuum will lift sand and gravel through a flexible hose to a sediment stockpile on the bank. Mr. Hoke will also consider methods of achieving a regular, automatic sweep of a channel by the dredge.

SOLAR GREENHOUSE (0139)

Cyndie & Stephen Tack
S.R. Box 51113
Mile 24 Chena Hot Springs Road
Fairbanks, Alaska 99701
488-9632

Amount Funded: \$5,000

The awardees will build a greenhouse which combines several of the better greenhouse construction and energy conservation principles now in use. The structure will be similar to a large cold frame with solar storage in the back wall and in the soil. Some of the features expected to make the greenhouse free of dependence on fuel heat from mid-April to late September include:

- a) Burying to north wall and parts of the other three walls to moderate the effect of very cold and very hot weather;
- b) Using solar collectors and an underground array of pipes to heat the soil;
- c) Using a massive north wall to store heat during the day and radiate heat at night;
- d) Glazing the greenhouse with a twin-wall stressed material;
- e) Making an easily-used blanket to cover the glazed surfaces at night.

OIL FIRED CLOTHES DRYER (0145)

Mike Potter
P. O. Box 80293
Fairbanks, Alaska 99708

Amount Funded: \$500

Awardee will convert a standard household dryer from electric to oil-fired hot water heat to take advantage of the oil-fired boiler which heats his house. Hot water will be piped to a radiator core which will be mounted on the rear of the dryer; air forced across the radiator will dry the clothes. The energy requirements and cost of drying clothes with an electric dryer will be measured before the conversion; when the oil-fired system is installed, its heat requirements will also be tested.

Mr. Potter says the high cost of electricity and gas, and the fact that a large number of Alaskan homes use hot water heat suggest significant potential savings.

METHYL-FUEL PLANT (0165)

Douglas Grimm
S.E. Applied Electronics
P. O. Box 324
Auke Bay, Alaska 99821
789-2542

Amount Funded: \$5,000

The awardee will build a scale model of a system capable of accomodating the electrical and automotive energy needs of a typical urban or rural residence in southeast Alaska. The methyl-fuel plant will produce approximately one gallon of methyfuel for every 20 pounds of waste material. This project will make use of the large quantity of sawmill wood chips available in southeast Alaska. Experimentation will also be done with many other forms of "garbage." The fuel produced will then be applied to a modified 4 H.P. internal combustion engine driving an 1800 watt generator. This scale model should supply about 1/10 of the electrical energy requirement of a typical residence.

HYDROELECTRIC GENERATOR (0155)

Richard Ford
P. O. Box 158
Copper Center, Alaska 99573
344-6988 or 822-5847 (work)

Amount Funded: \$2,500

Awardee will build a small-scale hydroelectric system to reduce his family's dependence on a diesel generator. The system will be mounted on a raft in the Copper River and provide enough electricity to the residence for 8 months of the year.

WOOD FURNACE (0136)

Donald Ruef
P. O. Box 1906
Palmer, Alaska 99645

Amount Funded: \$2,150

The awardee will build, instrument and test a wood-coal furnace with a fluid-filled jacket. The fluid tube will store heat and be controlled to produce a low-pressure hot fluid and not vapor. Mr. Ruef expects the furnace to deliver 100,000 BTU/H, provide long-term even heat, require no electricity, and be marketable at less than \$1,500 each.

ELECTRIC CAR (0098)

David Grove
214 Harwood Hall
University of Alaska
Fairbanks, Alaska 99701

Amount Funded: \$5,000

Awardee will build and test an electric car for operation in cold climates. The plans for the vehicle will be purchased, but modifications will be incorporated, such as the use of light weight aircraft steel, an insulated battery compartment, and solid state devices for startup. Mr. Grove expects to demonstrate that the electric car is uniquely suited to Alaska for three reasons: first, gasoline is

generally priced higher here; second, because pollution, especially ice fog, is a serious problem; and finally, because much of Alaska's road system is disconnected, the auto's 60-mile range per charge will not be a serious limitation.

SOLAR GREENHOUSE (0074)

Jeremy & Linda Weld
P. O. Box 165
Mile 128 Ft. Richardson Highway
Gakona, Alaska 99586

Amount Funded: \$5,000

The awardees will build an add-on solar greenhouse which will utilize a thick gravel pad to store heat from the greenhouse for later use in the greenhouse and in the attained cabin. The gravel pad will be insulated from the ground around it and a heat collector at the greenhouse ridge will pump warm air into it. In addition, a rain water collection system will be incorporated into the greenhouse such that the stored water will also bank heat.

AMBULANCE SPLINT (0027)

Steve Carney
Fire Department
University of Alaska
Fairbanks, Alaska 99701
479-7535

Amount Funded: \$200

Awardee will build a modification of the long spine board used by ambulances which he expects to be an improvement. His patient stabilization system will utilize vacuum "bean bags" in conjunction with conventional straps. The vacuum bags would rely on the same principal as the vacuum splints, be adjustable, and would attach to the board with velcro.

HYDROELECTRIC GENERATOR (0129)

Ted Neville
313 Lakeview Trailer Court
Fairbanks, Alaska 99701
456-8108

Amount Funded: \$350

The awardee will build a small-scale water-powered electric generator to be powered by a river. A paddle wheel's rotation will be translated by a 2:1 ratio gearbox, and then drive an electric motor. The electric motor, when driven, produces current. Mr. Neville hopes to produce enough current to run small power tools.

SOLAR HEATER (0065)

Chris Johansen
P. O. Box 81162
College, Alaska 99708
452-2153 (work) or 479-4563

Amount Funded: \$600

Awardee will use grant money to build a simple solar air heater which could be placed in window openings. The heater would consist of a plastic panel which would admit fresh cold air from outside, allow the sun to heat it as it rises toward the window opening, and have a simple thermostatic device at the top to allow air to pass in

only when it is warmer than the ambient room temperature.

WASTE-OIL HEATER (0106)

Donald Pendergrast

Amount Funded: \$250

S.R. Box 50342

Fairbanks, Alaska 99701

Phone: 456-3516 (home) or 356-1400, ext. 428 (work)

The awardee will build a stove that burns waste crankcase oil. The stove will provide a more complete use of a scarce resource and an efficient method of waste disposal. The design utilizes a discarded electric water heater, several frying pans, and generally available and inexpensive hardware.

EXPERIMENTAL GREENHOUSES (0180)

Jim Donally & Norm Stoppenbrink

Amount Funded: \$1,000

1014 East 11th, #4

Anchorage, Alaska 99501

Phone: 277-1794 or (message) 277-4050

Awardees will build three greenhouses to test the efficiency of a plastic product, called ACPS, as a greenhouse wall material. ACPS is commercially available in long sheets or on rolls. Its common purpose is as a packing stock for fragile merchandise. It is a clear plastic film with little bubbles in it which, Mr. Donally notes, when squeezed "give a satisfying little pop." But, the bubbles also seem ideally suited to provide insulating dead air space for greenhouse walls. The first greenhouse built will have only a 6-mil visqueen covering. The second greenhouse will have ACPS, and the third, ACPS plus an insulated north wall. Maximum-minimum thermometers will be installed in each greenhouse and daily readings taken to determine the length of frost-free season.

INDUCTION GENERATOR (0506-80D)

Alakanuk City Council
 City of Alakanuk
 P. O. Box 51
 Alakanuk, AK 99554
 238-3313

Amount Funded: \$4000

The use of an Enertech 1500 wind powered generator will create an energy conservation project for remote villages, and supply power to these remote areas on an uninterrupted schedule.

SOLAR SPACE HEATER (0226-80)

Alaska Alternative Energy Resources Center
 1069 W. 6th Avenue
 Anchorage, AK 99501
 274-3621

Amount Funded: \$1500

To construct an easily adaptable solar space heater for retrofitting onto existing homes and to conduct a workshop in conjunction with the construction. The simplicity of the construction of the solar collector should be conducive to assembly by the average Alaskan homeowner. At the workshops, the retrofitting topic will be combined with a weatherization session.

FURNACE CONVERSION (0068-80)

Don Bailey
 P. O. Box 70
 Anchor Point, AK 99566
 235-8485

Amount Funded: \$400

A unique conversion - from oil to wood. The conversion of the forced air oil furnace heating system is simple and is a means of beating the high cost of oil. The existing wiring will not be touched so a circulation fan can activate at the correct temperature and continue to blow air.

TREATMENT UNIT (0312-80)

Norman Bair
 Box 10043
 Dillingham, AK 99576

Amount Funded: \$1100

To help establish state regulations for the disposal of greywater. A 30 yard septic tank would be installed outside with a gravel filter installed downline in the basement of a home. The gravel filter would further purify waste material.

BATTERY OR FUEL CELL MADE FROM SCRAP METAL (0508-80D)

Thomas R. Berson
 SR 937
 Chugiak, AK 99567

Amount Funded: \$800

To develop a cheap, long-life, high energy battery or mechanically charged fuel

cell to be made from common materials or scrap metal. This will provide an alternative power/storage supply which could replace or assist fossil fuel generators, in vehicles and in home heating systems.

WINDOW INSULATION (0036-80)

Jim Cunningham
5300 "A" Street
Anchorage, AK 99504
278-2819

Amount Funded: \$200

With the use of styrofoam panels. Students at the Specialized Academic Vocational Education Center (S.A.V.E.) will participate and earn credits. Other schools will be invited to view the panels and share the resultant data to be recorded on comparative values of these and other types of window insulation.

DOG, WATER OR WIND POWERED WASHING MACHINE (0358-80 & 0359-80)

Bill Hall
SR 1438
Eagle River, AK 99577
694-2238 (message)

Amount Funded: \$400

To be used in remote region of Skwentna. For dog power, an exercise wheel will be used to harness the dog or dogs for operating the washing machine. The method would be demonstrated at local dog mushing club meetings.

GREENHOUSE (0515-80D)

K. Quinn Hart
SR 196 H
Eagle River, AK 99577
862-5292

Amount Funded: \$2200

An energy efficient greenhouse using soil thermal mass storage and waste heat recovery on a year-round basis. In the summer months, the excess solar heat collected is transferred and stored in the soil. In the winter, waste heat from the residential coal stove is recovered to maintain soil temperatures. Upon completion of construction, a workshop will be conducted.

WIND GENERATOR (0098-80)

Steve Hicks
Box 147
Glennallen, AK 99588
822-5872

Amount Funded: \$1600

To build and demonstrate a 12 volt generator constructed from junk auto parts. The main component will be a shortened rear axle which will serve as the propeller shaft. A demonstration seminar will be conducted in Glennallen upon completion of the project.

WATERPROOFING FOR EARTH SHELTER HOUSE (0165-80)

Marnie & John Isaacs
2418 Forest Park Drive
Anchorage, AK 99503
279-8900

Amount Funded: \$3300

To utilize and test existing material "Bituthene" for waterproofing house. Bituthene is used primarily in tunnels and subways. The Isaacs wish to demonstrate that this material will be more effective and less costly than other more commonly used products.

GREENHOUSE (0055-80)

Ed Knoebel
P. O. Box 84
Glennallen, AK 99588

Amount Funded: \$4100

Knoebel has excess domestic warm water from his home heating system. He plans to recycle this water to a greenhouse as a heat method. Tests will be run for a one-year period on the practicality of growing vegetables under these greenhouse conditions.

TRAILER STEERING DEVICE (0081-80)

Alex Matheson
1817 W. 13th Avenue
Anchorage, AK 99501
388-4618

Amount Funded: \$5000

To develop a remote control rear axle steering device for truck trailers. The problem with multi/trailer rigs is maneuverability. Three trailer rigs would be used more frequently if they were more maneuverable. In addition, a moveable rear axle will eliminate the problems of backing up a multi/trailer rig.

RECYCLING ALUMINUM SCRAP (CJ85-80)

John Phillips
4211 Cope, #3
Anchorage, AK 99503
272-7992

Amount Funded: \$700

This is an alternate method of handling scrap aluminum cans and other aluminum scrap material. A small crucible furnace will transform the scrap into ingots. The ingots could be packed in a small area per unit weight for economy of shipping.

GENERATOR (0332-80)

Radio Communications Inc.
3350 Mountain View Drive
P. O. Box 98190
Anchorage, AK 99508

Amount Funded: \$5000

To construct a hybrid solar panel/wind generator system supplemented by lead-acid battery plant, that would have the capacity to power a moderate 25 Watt 12 V.D.C.

load. The proposed system would be suitable for providing power to such equipment as microwave relays, VHF/UHF communications, repeaters, hydrologic telemetering instruments and low power television translators.

SOLAR HEAT HOUSE (0072-80)

Robert Reinhardt
General Delivery
Aniak, AK 99557

Amount Funded: \$5000

Will also provide heat for hot water heating system. During winter months, additional heat will come from a modified multi-fuel stove boiler. The heat house could also be used as a fruit drying house, a greenhouse and a clothes drying area.

BOILER SYSTEM (0155-80)

Alfred Doner
SR 5620
Wasilla, AK 99687
376-5540

Amount Funded: \$1800

Design and install heat storage tank with solar assist. This will demonstrate the feasibility of year-round wood burning boiler operation. This will also demonstrate the feasibility of adding a wood or coal burning boiler in series with any existing oil or gas-fired boiler.

SOLAR WOOD DRYING KILN (0116-80)

Bruce Forster
P. O. Box 1021
Homer, AK 99603
235-7286

Amount Funded: \$3000

This is an air transfer solar kiln. Forster is a cabinet maker and would prefer using local woods which are of higher quality than imported woods. The kiln will hold up to 2000 board feet of lumber (1" thick) and is designed to dry a load in approximately one month's time. The body is a two-layer sandwich of clear fibre glass supported by four insulated walls.

WIND GENERATOR (0540-80D)

William Hightower
P. O. Box 4 (Mile 24)
Moose Pass, AK 99631

Amount Funded: \$2600

Using auto electrical parts for 12 volt wind generator to light outbuildings such as chicken house, etc. A Savenius rotor will be installed on a hill with three or four alternators attached to it. The current will be transmitted to storage batteries in the outbuilding area. When 110 volt current is needed, a power inverter will be employed.

DIGESTER (0045-80)

Edward Johnson
P. J. Box 1347
Soldotna, AK 99669
262-7941

Amount Funded: \$5000

Methane gas producing digester which will generate energy as well as dispose of waste. Waste from the digester will be transformed into fertilizer. A reinforced 2000 gallon digester in four compartments will facilitate total digestion and keep the gas supply stable.

IMPROVED WILLOW RAKE (0374-80)

Cecil R. Jones
Star Route A, Box 49A
Homer, AK 99603

Amount Funded: \$3000

Designed to speed up farm land development. It will remove willow and alder roots in the area with little disturbance to topsoil. Current methods remove excessive topsoil with removal of growth.

FRUIT AND NUT TREE CULTIVATION (0298-80)

Karen Leis
P. O. Box 923
Homer, AK 99603

Amount Funded: \$1000

To grow various fruit and nut bearing trees in remote area. Orchard is planned on a remote plateau at the head of Kachemak Bay, east of Homer. Leis is a knowledgeable grower and believes Pecan trees and other varieties of fruits and nuts will do well on the site under proper controlled growing conditions.

PERMAFROST EXCAVATION (0232-80)

Charles Posciri
SR Box 9360
Palmer, AK 99645
745-3892

Amount Funded: \$5000

A pre-facture method for excavating permafrost and rock formations. The method is designed to save on gas and oil and at the same time preserve the environment by eliminating the major portion of environmental damage normally suffered during excavation.

HYBRID ELECTRIC CAR (0281-80)

Ricardo Quiroz
P. O. Box 770
Valdez, AK 99686
835-4614 or 835-4322 Ext. 229 (work)

Amount Funded: \$2300

To modify a conventionally powered gasoline engine in a 1970 Volvo station wagon. The Volvo presently gets 16 MPG and Quiroz hopes to bring that figure up to 75 MPG. This hybrid electric propulsion system is selfcontaining and self-generating. Emphasis will be geared to learning if additional modifications will be required

to produce a hybrid electric car compatible with Alaskan weather. A 16 gallon tank should yield about 1200 miles.

PLANT HYDRO FEED SYSTEM (0290-80)

Elizaveta Shadura
P. O. Box 181
Galena, AK 99741

Amount Funded: \$5000

Using the nutrient film technique which is a streamlined version of hydroponics. A recirculating system allows a weak concentration of a complete nutrient solution to constantly run by the plant roots. This method supplies a constant flow of nutrients that can be taken up by the roots on a continuous basis.

PASSIVE SOLAR HOME PLANS (0159-80)

Steven B. Smiley
SRA Box 41-C
Homer, AK 99603

Amount Funded: \$1700

To design standard superinsulated passive solar home plans that will meet FHA approvals. It is difficult to obtain FHA approval on a "custom" looking home, rather than a conventional design. These plans will combine energy-saving features in an FHA acceptable design.

SHUTTERS FOR GREENHOUSE (0327-80)

Ak. Federation for Community Self-Reliance
P. O. Box 73488
Fairbanks, AK 99707

Amount Funded: \$1000

Insulated shutter demonstration project on site of Federations's community garden project. Roll-down quilt/type shutters in super insulated solar heated greenhouse. The system would have the advantages of light weight, low cost and esthetic appeal. Local artists will donate their time to decorate the shutters. The shutters can easily be modified for residential use.

SUBTERRANEAN OUTBUILDINGS (0130-80)

Phillip Albert
General Delivery
Ruby, AK 99768

Amount Funded: \$4800

To build subterranean area for chickens, goats, etc. on the earth surface, a greenhouse will be constructed on the top of the animal stock outbuilding. Produce for local consumption would be grown in the greenhouse. Eggs and milk would be available from the chickens and goats on a year-round basis.

SOLAR THAWING OF PERMAFROST (0044-80)

Joseph Balch
Mile 34 Salcha
Fairbanks, AK 99701

Amount Funded: \$5000

Thermal tube method using heat jacket at base of tube. Could be used for specific

research programs. With the use of a wind pump and solar collector, could possibly supply water year-round in the remote regions.

EFFECTIVE U-VALUE MEASUREMENTS (0139-80)

Axel R. Carlson
SR Box 30183 Scenic Heights
Fairbanks, AK 99702
479-6434

Amount Funded: \$5000

To develop a technique with instruments to measure the effect of thermal mass, solar orientation and color of exterior surfaces. Also to determine effective U-values (R-value) of floors, walls and roofs below grade for earth shelter homes. Will also determine the effective U-values of heavy timber and masonry of walls above grade. A computer program will be developed to convert and tabulate the data as U-values.

ARCTIC HOME CONSTRUCTION (0505-80D)

Bobby Cloyd
3750 Geist Road
Fairbanks, AK 99701

Amount Funded: \$3400

Various techniques will be implemented by the vocational carpentry class at the Hutchinson Career Center. Results will be monitored and compared for effectiveness with other types of home construction.

SOLAR GREENHOUSE (0328-80)

Michael Crawford
Box 73560
Fairbanks, AK 99707
456-6843

Amount Funded: \$4800

An air/hydronic solar collector system. An attached solar greenhouse to be constructed on the south wall of the Two Rivers Grange (Alaska #3). Labor to be donated by members. The greenhouse will be utilized by the community, including the 4H Club and other young people's organizations.

HOME ENERGY SYSTEM (0118-80)

John Dillon
Mary Moorman
P. O. Box 81123
College, AK 99708

Amount Funded: \$5000

Plan to design, build and demonstrate hybrid solar, wood and coal energy system as conservation features in a home. There will be a solar-chimney attached greenhouse with energy storage in eutectic salts. Use will be made of locally available resources to avoid rising fuel costs.

METHANE GENERATOR (0362-80)

Chris Lamb
P. O. Box 602
Nome, AK 99762

Amount Funded: \$400

Utilizing honeybuckets with a two-stage generator. The two stages allow for continuous gas production. Disposal of human waste is a major problem in northern areas. Fuel costs are high. Lamb hopes to alleviate both problems with the generator.

AUTOMATED THERMAL SHUTTERS (0309-80)

Ed McGrath
P. O. Box 80807
Fairbanks, AK 99708
452-6690

Amount Funded: \$2400

Four motor operated retrofit automated shutters when combined with 2 panes of glass have an R value of 18 - substantially higher than most insulated shutters.

TECHNIQUE FOR SHALLOW SUBSURFACE EXPLORATION (0020-80)

Robert McHattie
Richard Jurick
1921 Capitol Avenue
Fairbanks, AK 99701

Amount Funded: \$5000

To be developed with an electromagnetic solid conductivity instrument to delineate permafrost and ground ice conditions for building, map subsurface conditions and for small placer and hard rock mining operations.

GENERATING SYSTEM (0538-80D)

Carl Pelz
P. O. Box 93
Petersburg, AK 99833

Amount Funded: \$5000

A hillside stream will be the energy source. A dam will be built 200 feet above the generating system. A pipe in the dam will guarantee a steady flow of water. A Pelton wheel will be used to transmit mechanical energy from the water to the generator.

DATA RECORDING INSTRUMENT (0205-80)

James Raymond
P. O. Box 81504
Fairbanks, AK 99708
456-3128

Amount Funded: \$1100

Will build a multi-purpose instrument for recording environmental data in remote regions. The data would provide information that could help to improve the design of buildings and other projects for suitability of construction in the wilderness areas.

SOLAR ENERGY HEATING SYSTEM (0064-80)

Richard Seifert
Gary Newman
Box 80147
Fairbanks, AK 99708

Amount Funded: \$5000

To purchase two identical thermal and flow monitoring systems, two differential thermostate controllers and temperature sensors and two recording and integrating pyranometers. Seifert and Newman will monitor the systems for the lifetime of the units. Seifert's system will be heating a basement using panel heating (pipes imbedded in a concrete pad) and Newman's system will be used to provide space heating and domestic hot water heating, with additional exchangers to be used for extended gardening ground warming at a later date.

SOLAR WOOD DRYING KILN (0248-80)

Charles Simmons
Box 81724
College, AK 99708

Amount Funded: \$2000

To dry wood for use in woodworking and woodcarving. This would enable artist Simmons to utilize local rather than imported wood. The kiln will utilize fiberglass for insulation on a 2 x 4 construction, with control from thermostate operated fans.

WATER HEATING (0177-80)

Leslie A. Viereck
SR 20791
Fairbanks, AK 99701

Amount Funded: \$2000

A method for heating domestic water by a combination of wood stove and solar panels. The solar panels will heat the water from March through October and assist in heating during late fall and early spring. The project is designed to demonstrate that domestic water need not be heated by oil or electricity in the interior of Alaska.

FISH DRYING PROCESS (0145-80)

Ole Wik
Savoonga, AK 99769

Amount Funded: \$5000

A method of drying fish in a vacuum chamber, powered by existing wind electric system. The Danes use a similar process called pressfisk, where the fish is squeezed into blocks during the process.

STEAM PLANT FOR SMALL BOAT (0262-80)

Ronald Klein
P. O. Box 1587
Juneau, AK 99802
586-9492 or 465-2925/465-2944 (work)

Amount Funded: \$5000

To install and modify a commercially made steam boiler and engine for a small launch hull. To demonstrate practical use of steam as a means of locomotion, especially in the southeastern area where wood is plentiful.

1 WATT TRANSLATOR (0166-80)

David Molvik
Narrows Broadcasting Corporation
Box 149
Petersburg, AK 99833
772-3770

Amount Funded: \$5000

Translators are low power repeater stations. This would be erected on a mountain top for energy generation via solar voltaic cells for the operation of radio broadcast transmission equipment.

HOME ENERGY CONSERVATION SYSTEM (0234-80)

Jay Moor
9175 Skywood Lane
Juneau, AK 99801
789-9583

Amount Funded: \$4800

A dual domestic system comprised of heaters, controls, and environmental stabilizers that can be coordinated by means of small computer, or operated manually when the electrical power supply fails. To demonstrate the system can be packaged in modules for easy adaption to professionally built housing in Alaska.

DEVELOPMENT OF CLAM HARVESTING TECHNIQUE (063-81)

Carl DeBoard
608 Kim Place
Anchorage, AK 99504
337-3191 or 344-9602

Amount Funded: \$5000

A clam dredge that is an amphibious vehicle that will travel in 7 feet of water before it floats. It could harvest razor clams 8 months per year, for 8 hours a day. Awardee will experiment with a design modification of a clam digger he has developed. It is anticipated the clam dredge could harvest a swath 4 feet wide and have a forward speed, while harvesting of 5000 feet per hour. A beach area of 20,000 square feet per hour could be harvested.

DEVELOPMENT OF A CAM OPERATED ARCTIC DOOR DESIGN (061-81)

Phillip W. Sanders
P.O. Box 80982
Fairbanks, AK 99708
479-5920

Amount Funded: \$1100

To design a door with beveled edges and a cam operated pin hinge to eliminate the problem of air infiltration of exterior doors. Awardee will convert standard metal door. The door would revolve around one central axis. As the door is opened, the cam lift mechanism raises the door and allows it to clear the threshold. As the door closes, the cam drops the door back down on the threshold for a tight seal.

TO GROW FRUIT TREES IN THE YUKON-TANANA UPLANDS (115-81)

Bonnie Friedman
P.O. Box 81110
College, AK 99708

Amount Funded: \$1650

To coordinate the experience, research and expertise of those growing fruit trees in Alaska and to utilize those methods of growing fruit trees used in other arctic countries. To date, results are not recorded by individuals in a scientific manner and results are not passed along to other Alaskans. The grant will permit an investigation through experimentation into the response of fruit trees grown through a variety of techniques.

TO CONVERT A VW BUG TO A HYBRID-ELECTRIC VEHICLE (110-81)

W. Charles Newell
P.O. Box 80302
College, AK 99708
456-2800

Amount Funded: \$2700

To attempt to demonstrate a viable transportation design which will eliminate wasteful warm-up periods, provide reliable car service and conserve fuel emissions. The prime movers in the system would be eight 12 VDC batteries in series connection and a 2000 watt motor generator set.

TO USE SPILL-OVER ENERGY FROM A HYDRAULIC WINDMILL (117-81)

Clark Corbridge
7420 Tikchik Circle
Anchorage, AK 99504
333-4587 or 279-0641

Amount Funded: \$5000

To build a windmill incorporating a controllable-pitch, full-feathering propeller; hydraulic control of propeller pitch, a hydraulic pump, motor and 'lock.' If successful, the project will prove the viability of the theoretical ideas concerning the use of full-feathering, ground controllable propellers and hydraulic methods of power transportation for windmills. Alaskans could benefit from wind-power systems, which are quieter and therefore, more environmentally acceptable. Because the hydraulic windmill should provide that all adjustments be made from the ground, it would be substantially safer than a conventional windmill.

EQUIPMENT FOR SENSITIVITY AND COLD TEMPERATURE TESTING OF SMOKE DETECTORS (131-81)

John Benevento
Geophys. Inst., U of A
Fairbanks, AK 99701
479-7560

Amount Funded: \$4900

To be used for equipment in basic laboratory tests for smoke detectors to be used in the bush. Tests would be run that would be difficult to document and evaluate under field test conditions.

HEAT PUMP FOR FOUNDATION STABILIZATION (118-81)

R. Dale Guthrie
SR Box 20044-B
Fairbanks, AK 99701
479-6034 or 479-7142 (work)

Amount Funded: \$5000

This would be a dual function heat pump; to stabilize a house foundation on permafrost with energy efficient interior heating. Building on permafrost in Alaska is expensive and sometimes unsatisfactory. It is difficult to remove subfoundation heat in an even and controlled manner without producing the undesired side effects of expansion and differential heaving of the slab and foundation. It may be possible to avoid these problems and at the same time, salvage building threatened by permafrost with a modification of a heat pump system already in existence. Instead of pumping heat into the basement from the soil surrounding the house, heat could be evenly extracted from beneath the existing slab.

TO INSTALL A HIGH-PRESSURE JET MODIFICATION TO A CLAM HARVESTER (066-81)

Ed Stultz
7020 E. 11th
Anchorage, AK 99504
333-4348

Amount Funded: \$5000

A competent hand digger can harvest 200 to 300 pounds of clams per day. It is proposed that the suggested high-pressure digger could harvest 5000 pounds per hour, by using a water-pressure method.

DEVICE TO TEST SOIL STRENGTH (068-81)

Douglas Beaudoin
50 Valley Drive
Fairbanks, AK 99701
488-9228

Amount Funded: \$2050

This would be a tri-dimensional stress-strain controlled field testing apparatus. It would predict settlement rates of foundation materials. It would also determine size, shape and type of foundations and footings for each type of soil condition. The objective would be to perform field tests throughout the Anchorage and Fairbanks areas where foundation failures occur and where cohesive soils exist.

TO DEVELOP A SUBMERSIBLE INVESTIGATING DRONE (069-81)

Randy and Larry Smith
P.O. Box L
Haines, AK 99827
766-2810

Amount Funded: \$5000

For underwater research, mapping and salvage. The drone would also have application in pollution investigation, fisheries and halibut studies, harbor maintenance and light underwater salvage. It would be an unmanned, remote-controlled drone capable of being towed and/or maneuvered under its own power at ocean depths up to 35 fathoms. It would fit in a standard hold of any vessel over 50 feet in length and could be lowered into the water with a moles winch.

TO STUDY THE FEASIBILITY OF MIGRATORY BEE/HONEY OPERATION SYMPATHETIC TO DELTA BARLEY PROJECT (070-81)

Paul Carlson
Chilkat Valley Farm
P.O. Box B
Haines, AK 99827
766-2770

Amount Funded: \$2350

Bees would be purchased and installed in the Delta area. Bees from Haines would be sent by truck to the Delta area where eight acres of rapeseed will be planted for bee pasture. The bees would then be transported back to Haines following the bloom period. The benefit would be increased honey production, a sounder agricultural program, utilizing honey bee pollination for seed set and fruit yields.

WIND POWERED HEAT PUMP AND LIGHTING SYSTEM (003-81)

Erick Olson
P.O. Box 393
Haines, AK 99827

Amount Funded: \$5000

Project will demonstrate the feasibility of heating and lighting a house in south-east Alaska using wind power. The power will be generated by a 10 kilowatt "Elektro" wind generator and fed through battery banks to a six kilowatt modified sine wave inverter. The heat pump will optimize power that is produced by turning energy into heat in an energy conservative manner.

MARICULTURE OF SUBTIDAL RED SEaweEDS (005-81)

Natasha Calvin
P.O. Box 112
Auke Bay, AK 99821

Amount Funded: \$5000

The species of Alaskan seaweeds of the Rhodophyta, or red algae group, when used as natural herbs, applied topically, give significant relief from the symptoms of herpes infections. Awardee would dive in many places of the outer Chik... of area which provide algae species.

TO CONSTRUCT A DUAL-LAYER GREENHOUSE ON ALASKAN PENINSULA (020-81)

Charles & Sara Hornberger
P.O. Box 69
Illiama, AK 99606

Amount Funded: \$3400

To demonstrate that it is possible to grow major portion of food needs on the Alaskan peninsula and enjoy a growing period of 8 months. The greenhouse would be geographically situated and constructed to utilize solar heat to the maximum efficiency.

TO REFINE INDOOR HYDROPONIC SYSTEM (022-81)

Ira Winograd
435 Kennedy St.
Juneau, AK 99801
465-3991 (day) 586-6417 (eve.)

Amount Funded: \$1500

To create an indoor hydroponic system for home use producing vegetables at a price which is cost competitive with market produce. Compact in size, 3 feet by 8 feet, awardee plans to market the units in kit form.

TO DEVELOP A METHOD OF PRODUCING ETHANOL ALCOHOL (026-81)

Craig Delbridge
% Northland Maint. Co.
Pump Station #1
P.O. Box 73608
Fairbanks, AK 99707
479-3983

Amount Funded: \$5000

Alcohol would be remove from fermentation as it is formed, by tying together the fermentation and distillation functions in a continuous loop. The efficient production of ethanol as a fuel could cut costs in marketing Alaskan grain and Alaskan wood products. Exportation to overseas markets is almost prohibitive at this time, due to high transportation costs.

HIGH TEMPERATURE SURFACE COMBUSTION TECHNIQUES (028-81)

Horace Simmons
Box 2464
Kodiak, AK 99615
486-4890

Amount Funded: \$1500

Incomplete combustion in stoves and furnaces increases fuel consumption. Awardee will try to eliminate this problem by constructing two types of surface combustion units. One will be intended for use with natural-draft oil ranges and heaters and

TO CONSTRUCT A CHICKEN HOUSE AND SOLAR PIT GREENHOUSE (031-81)

with wood and coal heaters. Another type will be constructed for use in forced-draft furnaces and boilers.

Joy Orth
P.O. Box 1171
Wrangell, AK 99929

Amount Funded: \$4200

To develop a system of food production which would provide a continuous supply of fresh vegetables, eggs and meat suitable to southeast Alaskan conditions.

COMPOSTING TECHNIQUES EXPERIMENTATION (033-81)

Eugene Gerow
P.O. Box 8265 NRB
Kenai, AK 99611
776-8996

Amount Funded: \$4900

To develop a process of utilizing heat from decomposing brushwood and trimmings. Branches are chipped and stacked. Water is circulated through the stacks where it is heated by the exothermic reaction of the decomposing brushwood. This hot water is then used to heat buildings. Completion of the decomposition cycle results in a high quality compost that can be tested for use for agricultural purposes.

TO REUSE WASTE HEAT FROM LAUNDROMAT (038-81)

James Wilcox
1914 Churchill Ct.
Juneau, AK 99801
586-2637

Amount Funded: \$4400

Rocks would collect heat while the dryers are in use. After dryers have run, tops of rocks should be warm enough to change temperature of water in pipes, which would lower cost of heating water. Rocks would be in a box above the dryer, with vents entering from the dryers. Heat recovery fans on top of the box would draw heat back from rocks and distribute heat to building.

TO CONSTRUCT A SOLAR SEMI-SUBTERRANEAN BARN/ROOT CELLAR (052-81)

Jack Detzel, Jr.
P.O. Box 278
2 Mile Tanana Loop Rd.
Delta Junction, AK 99737
895-4696 (work)

Amount Funded: \$4000

To make use of the heat loss from poultry and passive solar collector in the barn and root cellar. The root cellar would provide necessary storage area for vegetables. The barn would provide shelter to laying chickens and turkeys. Vegetables, eggs and poultry could be provided to Delta residents all year around.

CONSTRUCTION OF ELECTRIC HYBRID CAR (057-81)

H. J. Coutts
Mile 348 Nenana Hwy.
Nenana, AK 99760
353-1106 (Mon. - Thurs.) 479-3645 (Fri.)

Amount Funded: \$5000

Not only construct but demonstrate its use under cold climate conditions. The car will be assembled from off-the-shelf components. Fuel economy, which may approach 200 miles per gallon including electric power consumption will be measured and reported.

IMPROVED HYDRAULIC RAM FOR USE ON STREAMS IN INTERIOR ALASKA (056-81)

N. Meade Riche
1379 Alaska Hwy.
Delta Junction, AK 99737
895-4842 (message)

Amount Funded: \$4900

A lighter, more compact and more efficient ram than used now. It will be fabricated from local materials and will be easy to install. The renewable hydro-power will be used in the nearby stream to pump water to gardens, greenhouses and animal barns, without using electric-powered or gasoline-driven engine pumps currently in use.

WOOD FUELED ELECTRICITY GENERATOR (059-81)

Richard Miller
P.O. Box 4005
Kenai, AK 99611
283-4426

Amount Funded: \$5000

To build and demonstrate an efficient, technologically simple producer gas refinery to convert firewood into a flammable gas vapor to fuel a portable piston driven electric generator. This would provide a means for comparatively economical sources of electricity for many Alaskan areas where conventional means have proven too costly.

TO DEVELOP A MICRO HIGH HEAD HYDROELECTRIC SITE FOR REDUCTION OF FOSSIL FUELS (077-81)

Kenneth Cassell
568C Thane Rd.
Juneau, AK 99801
586-2394 or 586-3911 (work)

Amount Funded: \$5000

Along the five mile length of Thane Road in Juneau, there are 27 streams; all having potential to produce electricity. The need for fossil fuel would be less by promoting the use of micro hydro. A community involvement program is planned in all facets of the project.

TO REUSE WASTE COMPUTER PAPER (079-81)

Nancy North
401 3th St., #108
Juneau, AK 99801

Amount Funded: \$1000

To find a secondary use for waste computer paper which is thrown away in vast amounts in the State of Alaska offices.

EMERGENCY SOLAR POWER FOR SMALL BOATS (004-81)

George Olanna
Shishmaref, AK 99772
479-7987 or 452-6519 (home)

Amount Funded: \$3000

To use the photovoltaic application of battery charging for boats. This could be used not only to start the motor, but operate CB radios. There is almost 24 hours of sun during the spring seal hunt and, as batteries very often go 'dead', this could be a method to possibly save the lives of hunters who are 75 miles out sea.

TO RECYCLE ALUMINUM CANS (013-81)

Daniel Moen
Kodiak Scrap Metals
P.O. Box 3074
Kodiak, AK 99615
486-3881

Amount Funded: \$2400

To modify a log-splitter for the purpose of crushing cans. This method of decreasing volume of used cans would be especially beneficial to the bush country, where disposal methods are a problem.

RIVER-POWERED ELECTRICAL GENERATOR (021-81)

Pete Brown
General Delivery
Aniak, AK 99557

Amount Funded: \$3000

Using the power of the river in a similar manner as the fish wheel. The 12 VDC generator would be designed to power lights, a freezer and power tools at a fish camp.

INSTALLATION OF SELF-TIMER SILENCERS ON SMOKE DETECTORS (130-81)

Nancy Smoyer
Geophys. Inst., U of A
Fairbanks, AK 99701
479-7125

Amount Funded: \$5000

There is a high incidence of false alarms in smoke detectors now being used in Alaskan villages. A simple electronic circuit has been designed which will allow de-activation of smoke detectors for ten minutes, by pushing a remotely connected push button. The awardee will use the grant to construct approximately 100 of these devices for installation in six villages.

TO DIVE TO RECORD ABUNDANCE AND DISTRIBUTION OF SEAWEEDS (006-81)

Robert Ellis
P.O. Box 112
Auke Bay, AK 99821

Amount Funded: \$5000

Awardee is an experienced research diver. Collect plants for microscopic inspection for possible use as medicine and food. At present, there is not a systematic, coordinated effort being expended in Alaska in this area.

1982 Northern Technology Grants Projects

WOOD UTILIZATION SURVEY IN THE FAIRBANKS NORTH STAR BOROUGH (N-82-01)

Steve Laroe
226 Glacier Avenue
Fairbanks, Alaska 99701
456-6094

Amount Funded: \$2500

The Interior Woodcutters Association will conduct a survey to determine if adequate wood supplies are available for domestic and commercial use. Due to an increased demand for fuel wood in the area, there is a notable decrease in available areas for wood cutting. 1,200 questionnaires will be sent to Fairbanks residents to determine the actual demand for use of firewood in the area. The Association's goal is to educate Alaskans concerning the use of timber and to promote the proper use and management of this resource in interior Alaska on a sustained yield basis.

DEVELOPMENT OF AN AUTOMATIC AND MANUAL FUEL-SAVING FLOOR REGISTER (N-82-02)

Lone Wagner
919 Cherry Street
Anchorage, Alaska 99504
338-4555

Amount Funded: \$4000

The register will direct the air in a heating system ductwork to the area of a room most in need of heat. Directional louvres will automatically direct initial cool air to the ceiling area. As air becomes warmer, it will be directed to floor area. A two-selector manual system will operate on the same principle. The plastic louvred register will be mounted over the outlet of a conventional forced air heating system.

FROZEN FOOD PROCESSING PLANT (N-82-14)

Max Stark
St. Rt. 10603
Fairbanks, Alaska 99701
479-2891

Amount Funded: \$3750

The purpose of this project is to grow broccoli, cabbage and cauliflower and to explore methods of freezing these products on a large scale. Produce will be grown by the awardee, as well as 4-H members and other residents. Plans for a much larger food plant will be undertaken if the smaller plant is successful. Stark is a retired vocational agriculture teacher and is currently supervisor of the Alaska Experimental Farm.

DOCUMENTATION OF OFF-PEAK ELECTRIC HEATING SYSTEMS AND USAGE (N-82-23)

Albert Shaw
631 West 11th Street
Juneau, Alaska 99801
586-1602

Amount Funded: \$500

The problem to be addressed is the apparent lack of information on electric off-peak heating systems. The grantee will collect and document the names of suppliers of these systems plus information on what utilities are doing to implement such systems. The information could be used by individuals and utilities to determine if off-peak electric power is adaptable to their particular needs.

DESIGN, DEVELOP AND TEST MANUAL, SEMI-AUTOMATIC AND AUTOMATIC CONTROLS FOR THERMAL SHUTTERS (N-82-26)

John Davies (Ph: 479-7424)
Richard Siegrist (Ph: 479-7131)
SR 20123-K
Fairbanks, Alaska 99701

Amount Funded: \$4900

The grantees feel that energy-efficient thermal shutters will not be used by Alaskans to any degree until reliable, automatic controls are available at a reasonable cost. The four control designs will be: a single shutter manually cranked from the interior of the house; single or multiple shutters semi-automatically cranked by a switch-activated motor; multiple shutters automatically cranked in unison by a motor controlled by hard-wired electronics that monitor light, temperature and/or time of day, and multiple shutters automatically and individually cranked at arbitrary times by a motor controlled by software-based microcomputer electronics that monitor a large number of environmental conditions.

DESIGN AND CONSTRUCT WASTE OIL FURNACE (N-82-44)

Frank Abegg III
3762 Erickson Road
Fairbanks, Alaska 99701
479-6045

Amount Funded: \$3450

The proper disposal of waste oil is an ongoing problem. The Environmental Protection Agency and the Alaska Department of Environmental Conservation encourage disposal through incineration. Although the cleanest method, it too can create pollution. The design for this prototype waste-oil fired hot air furnace will enable it to generate up to 100,000 BTU/Hour for space heating. The grantee has extensive experience in this area and has marketed many devices such as this. However, although there are many waste oil burners on the market there still is not one designed for Alaska's unique conditions that can burn more than a few gallons per day. The furnace will use a standard high pressure fuel oil burner modified to burn waste oil. The furnace will be capable of operating on a wide range of oils which could be stored underground in a heated tank.

TO DEVELOP A MICROPROCESSOR CONTROLLER TO OPTIMIZE HOT WATER HEATER USAGE (N-82-49)

Richard Jablonowski
Box 638
Juneau, Alaska 99802
586-3833

Amount Funded: \$5000

The project will utilize a microcomputer to design the logic for and test the energy savings of an "intelligent" black box controller for domestic hot water heaters. The computer program will be able to direct the controls to turn a hot water heater on and off; sense thermostat "on" and "off" conditions; sense requests for hot water (flow or pressure changes); measure, and record and analyze operating characteristics for financial and energy analyses. The computer's data will be doublechecked by cumulative energy meters. The final outcome will be the development of "micro-chips" as the major component and memory of these proposed devices which will be installed, at a minimal cost, in hot water heaters.

BANDSAW POWER ALTERNATIVE FOR BUSH AREAS (N-82-51)

Matthew Kirchhoff
Box 8800
Port Alexander, Alaska 99801

Amount Funded: \$500

The absence of electricity in many rural Alaskan communities prohibits the use of power tools. Using a commercial bandsaw kit, the grantee proposes to build a bandsaw and utilize a treadle in lieu of power. Components for the treadle design are readily available. A 50 pound automobile flywheel, pulleys, shaft, gears and foot sprocket will be used to activate the bandsaw. He estimates that the lowest gear setting will yield a blade speed of 340 feet per minute, and the highest gear setting will yield a blade speed of 4900 feet per minute. His ultimate goal is to produce the kits for use by other Alaskans in remote areas.

CROSS-TRANSMISSION OF COCCIDIOSIS BETWEEN WILD AND DOMESTIC ALASKAN SHEEP (N-82-72)

Carol Nielson
P. O. Box 81751
Fairbanks, Alaska 99708

Amount Funded: \$5000

In central and northern Alaska, the further development of commercial sheep herds as a local source of meat through "fat lamb" production would probably involve summer pasture grazing and winter confinement feeding. While on pasture, it is very possible that domestic lambs and ewes could acquire coccidia, harbored by Alaskan Dall sheep. The grantee proposes to investigate the possibilities for cross-transmission of coccidiosis between Dall sheep and domestic sheep by determining if both kinds of sheep harbor similar species of Eimeria and if infective coccysts from wild sheep can cause coccidiosis in susceptible domestic lambs. Alaskans who are considering commercial sheep-raising, even on a small scale, need to know if the use of summer pastures will expose their animals to increased risk of coccidiosis.

STUDIO-SIZED, HYDRAULICALLY POWERED IMPACT MILL (N-82-77)

Stannard
'Connor
Fairbanks, Alaska 99701
479-1008

Amount Funded: \$4100

To address the high cost of imported clay and the unavailability of local sources, the applicant plans to develop a mill to pulverize local ceramic raw materials. It will not only provide an example of one person's ability to subsist on local materials, but will also provide other potters in the Fairbanks area with practical experience so that they too can extend their ceramic endeavors without being completely dependent on outside suppliers.

SOIL HEATED FOOD PRODUCTION WITH SEEP IRRIGATION (N-82-87)

John Quirk
P. O. Box 29
Galena, Alaska 99741
656-1238

Amount Funded: \$3750

Hot water plastic pipe will be placed two feet apart underground, and 18 inches deep to use the waste heat from the Ruby, Alaska powerplant water jacket heat to warm the soil from April through September. Seep irrigation will be used along all the rows and slitted row covers on two rows for early production. This should extend the growing season and increase the production of vegetable crops.

WINTER STORAGE FOR ROOT CROPS (N-82-103)

Stanford Gurtler
General Delivery
Ruby, Alaska 99768

Amount Funded: \$4950

To build a 24' x 48' root cellar for winter storage of excess vegetables. This will be a village effort and will eventually be turned over to the local school as a students' project. The awardee is a native rural Alaskan trained in arctic agriculture by the local Learning Center.

DEVELOPMENT OF A LOW-COST, LIGHTWEIGHT, SOLAR SNOW MELTER FOR EXPEDITIONARY AND REMOTE SITE USE (N-82-107)

Matthew Sturm
Dan Solie
Geophysical Institute
University of Alaska
Fairbanks, Alaska 99701
479-7369

Amount Funded: \$1300

To maximize the amount of solar energy collected in the snow melting device, maximize the efficiency of the heat transfer process to the snow and minimize the heat losses. An important part of the work will consist of experimenting with a variety of materials in a number of configurations in order to determine the best possible arrangement. Obtaining water is often a problem in cold climates.

Despite the limited availability of sunlight, it is possible to melt snow using only the sun's rays.

TO DEVELOP A HYDRO-POWER GENERATION SYSTEM (N-82-109)

Michael Loeffler
P. O. Box 595
Chugiak, Alaska 99567
694-3920

Amount Funded: \$5000

To build a turbine test unit which will incorporate various impeller designs and test in several locations under different water conditions. The system will need little, if any, stream damming and components are off-the-shelf items that are readily available and inexpensive. The ultimate goal of the project is to produce inexpensive kits simple enough for Alaskans in remote areas to build.

MONITORING OF INTERIOR WINDOW INSULATIONS (N-82-80)

William McDonald
James Bershire
1551 East Tudor
Anchorage, Alaska 99507
274-2627

Amount Funded: \$4650

Since determining the right type of thermal shutter in Alaska has yet to be undertaken, the awardees propose to gather and disseminate information on the performance of several different types of interior shutters, in actual application in southcentral Alaska. The approach to monitoring will be twofold; microprocessor measurements of heat loss through the windows with and without shutters in place, and visual observation with a log noting condensation problems that may exist. The period of testing will be one complete heating season.

INSTRUMENTATION FOR A SMALL HYDRO-POWER PROJECT (N-82-108)

Louis Butera
University of Alaska, Anchorage
274-9344

Amount Funded: \$3750

The project will enable the collection of data to substantiate and make possible the compilation of an Alaskan Small Hydropower Guide. The instrumentation will be installed on a 5 KW hydroelectric project currently under construction on a local stream.

FISH MEAL AND OIL PRODUCING RAFT (N-82-119)

John Stam
Box 21
Galena, Alaska 99741

Amount Funded: \$3800

The awardee is a subsistence fisherman who has an alternative for current fish camp methods of cutting and drying fish for use as dog food. He proposes to build a large raft, using oil drums for flotation. The whole fish would be boiled in large containers aboard the raft, the excess water drained off, and the remaining fish sludge laid out under the raft roof to dry. Using this method, fish dries in 2 to 4 days, as opposed to the 1 to 2 week period on racks at the fish camp and there is no waste of fish. When the fish is dried, it will be mixed with dog meal to provide a nutritious feed all winter.

HYDROGEN GAS GENERATION BY AND FOR BOATS (N-82-38)

Joseph Charles Black
Dawn Lee Black
Box 1912
Kodiak, Alaska 99615
486-4666 or 5516

Amount Funded: \$5000

Although the testing is being conducted in Kodiak the proposal is based upon research conducted by Paul H. Lee, Research Physicist, University of California - Santa Barbara. Dr. Lee has offered to loan the awardees a 12 ft. buoy to investigate the possibility of producing hydrogen gas as fuel to power a boat. The buoy would be cabled to an electrolysis system in the boat that would produce hydrogen gas. The hydrogen gas would be stored in metal hydride flakes. In turn, heat would release the gas from the flakes.

Dr. Lee's approach is to use inertial coupling to design a generator for buoys. The generator has only one moving part. It is carried by the buoy for the purpose of recharging its batteries. The device is hermetically sealed from the ocean environment. The power it will produce from a 3-ft. wave, having periods ranging between 4 and 8 sec, is substantially that near 12 watts. For a 5-ft. wave, a maximum power of over 40 watts can be produced.

In conjunction with the project, the awardees will produce an educational film depicting step-by-step procedures. The film will be shown on public television statewide.

According to the awardees, the village of Old Harbor on Kodiak Island has been designated for a pilot program by the Alaska State Division of Energy for conversion to hydrogen gas with the use of wind power. The awardees think that the use of tidal/wave power to produce hydrogen gas as outlined in the proposal, will be timely.



G

THE ALASKA COUNCIL ON SCIENCE AND TECHNOLOGY

RESEARCH ACTIVITIES
FUNDED BY
THE ALASKA COUNCIL ON SCIENCE AND TECHNOLOGY

SEPTEMBER 1982

TABLE OF CONTENTS

Geothermal Energy Resources of the Lower Susitna Basin.....	1
Effects of Commercial Television on Rural Alaskan Children.....	1
Persistence of Herbicides in Agricultural Soils.....	2
Snowpack Structure and Regional Avalanche Hazard Forecasting.....	2
Forest Ecosystem Management Model.....	3
Volcano-Glacier Interactions on Mt. Wrangell.....	3
Alaska Earthquake Catalog.....	4
Enhanced Oil Recovery.....	4
Near-Shore Bottomfish Management Program.....	5
Effect of Hydrocarbons on Fish.....	5
Study of Wind Characteristics for Applied Wind Power.....	6
Influence of Climatic Fluctuation on Permafrost.....	6
Solar Radiation Assessment.....	7
Biogeochemistry of Arsenic Mine Drainage.....	7
Study of Airborne Pollen and Spores for Medical Purposes.....	8
Fate of Fertilizer Nitrogen in Agricultural Soils.....	8
Growth Rates in Muskox Calves.....	9
Impact of Community Participation on Rural Education.....	9
Humpback Whale Survey in Prince William Sound.....	10
Arctic Alaska Soils Data Base.....	10

TABLE OF CONTENTS - continued

Effective Teachers in Rural Alaska.....11

Genetic Analysis of Biting Alaskan Black Flies.....12

Evaluation of Emergency Trauma Training in Logging Camps
in Southeast Alaska.....12

Northern Plants Documentation Center.....13

Studies of Alaskan Duise (Marine red algae).....13

Alaskan Tephrochronology Project.....14

Coastal Flooding by Storm Surges & Objective Forecasting
Procedures.....14

Yukon-Kuskokwim Coastal Community Harvest Disruption Study.....15

Sixty Seconds of Science.....15

Under-Ice Navigation by Seals.....16

Removal Process of Air Pollution Particles by Ice Fog Crystals.....16

Study of Implementing Alaska's Bilingual Education Policy.....17

Arctic Research Ship Design (Phase III).....17

GEOTHERMAL ENERGY RESOURCES OF THE LOWER SUSITNA BASIN

Principal Investigators: Donald L. Turner
Eugene M. Westcott
Geophysical Institute
University of Alaska
Fairbanks, Alaska

Amount Funded: \$149,664

This project proposes the continuation of geothermal exploration in the lower Susitna valley near communities along the Parks Highway. Very large areas in the Willow-Wasilla-Big Lake region show substantial geothermal resources exist, but there are gaps in the data base outlining this resource.

Proposed follow on work will focus on providing a much better definition of the nature and area and vertical distribution of the geothermal system and on providing specific recommendations for exploratory drilling. This is one of the few areas in Alaska where a sizeable future population could be located directly over a large geothermal resource that can be economically utilized.

EFFECTS OF COMMERCIAL TELEVISION ON RURAL ALASKAN CHILDREN

Principal Investigator: Norma Forbes
Center for Cross Cultural Studies
University of Alaska
Fairbanks, Alaska

Amount Funded: \$77,714

The proposed research is the third phase of a study of effects of the introduction of television on rural Alaskan Native children.

Data will be collected in two Tlingit-Haida villages in Southeast Alaska and four Eskimo villages in the Kotzebue Basin. Villages in each area are paired such that one had television and one did not during an earlier phase of the study. All village sites now have television. A wide range of social, psychological, and educational data will be utilized, with most of the measures reflecting television's role as a change agent.

PERSISTENCE OF HERBICIDES IN AGRICULTURAL SOILS

Principal Investigators: C.W. Knight & J.S. Conn
Agricultural Experiment Station
University of Alaska
Fairbanks, Alaska 99701

Amount Funded: \$132,973

Agricultural acreage in the Alaskan Interior is increasing at a dramatic pace. By 1990, approximately 500,000 acres are expected to be under cultivation. The majority of the acreage will be located in the interior. A complicating factor in this development is that it is occurring in the sub-arctic, where little research has been undertaken to determine the effect of cold soils, long photoperiod, and short growing season on the various agroecosystems. One such component is agricultural herbicides. Herbicides are used extensively in agriculture throughout the developed world and now in Alaska.

Since persistence of herbicides could result in damage to herbicide-susceptible rotational crops, or in longterm buildup of residues sufficient to damage even lesssusceptible crops, information on herbicide degradation is urgently needed.

This information would be directly useful to extension personnel and farmers for: selection between alternative herbicides; planning clearing practices that optimize soil pH and organic matter content for minimizing herbicide buildup; and in the planning of crop rotation sequences. The information would also benefit those evaluating the length of environmental impact that would be caused by herbicide contamination of non-agricultural lands.

SNOWPACK STRUCTURE AND REGIONAL AVALANCHE HAZARD FORECASTING

Principal Investigator: Edward R. LaChapelle
Professor of Atmospheric Sciences
and Geophysics
University of Washington
Seattle, Washington

Amount Funded: \$28,503

Forecasting avalanches for widely varying mountainous terrain is a growing problem for many areas throughout the world. It is proposed that the role of snowpack structure analysis be formalized and included into regional avalanche forecasting.

A computer program will be applied to a large data base in order to isolate snowpack features that discriminate stable from unstable conditions. This information can then be synthesized with meteorological data into an operational guidance model for avalanche forecasting in Alaska.

FOREST ECOSYSTEM MANAGEMENT MODEL

Principal Investigator: John Fox
Institute of Arctic Biology
University of Alaska
Fairbanks, Alaska 99701

Amount Funded: \$63,236

There will be increasing utilization of interior Alaska forests in the next several decades for saw logs, house logs and firewood. The effects of all management options cannot be evaluated by field studies alone because of the costs and time lags involved. The alternative, increasingly in use now in the eastern U.S., is development of forest growth and ecosystem computer simulation models. Such models aid in the selection of possible field experiments and in the refinement through field studies of the assumptions rationale of the models and consequently of predictive capabilities.

There is a current need for forest production-decomposition-nutrient exchange models capable of predicting effects of forest management practices and climatic changes for interior Alaska forests. A large data base now exists, suitable for building a first generation of such models fully comparable to, or even exceeding performances of the models currently used for eastern deciduous forests.

Such a modelling program would benefit and complement current management oriented research by the state and federal institutions in Alaska.

VOLCANO-GLACIER INTERACTIONS ON MT. WRANGELL

Principal Investigator: Carl S. Benson
Professor of Geophysics and Geology
Geophysical Institute
University of Alaska
Fairbanks, Alaska

Amount Funded: \$154,500

A major goal of this proposed research will be to complete selected parts of research which deals with the behavior of glaciers on the flanks of Mt. Wrangell. (Mt. Wrangell is an explosive volcano similar to Mt. St. Helens. It is the northernmost and one of the largest active volcanoes on the Pacific Rim.)

The research will cover site selection for a deep ice core to be obtained in 1982 for analysis of climatic and volcanic history. The research will also continue detailed monitoring of volcanic activity. Monitoring is important because of the three-fold increase in heat from Mt. Wrangell since the Mt. St. Elias earthquake in 1979 and the increased activity currently reported by long-term residents of the Copper Valley.

ALASKAN EARTHQUAKE CATALOG

Principal Investigator: Niren N. Biswas
Geophysical Institute
University of Alaska
Fairbanks, Alaska 99701

Amount Funded: \$128,334

It is proposed to establish and test a homogeneous catalog of Alaskan earthquakes with local magnitude greater than or equal to 4.0, for the period January 2, 1966 through December 31, 1980. Prior to the great Alaskan earthquake of 1964, there were only two seismographic stations in Alaska. In 1964, the National Weather Service began establishing a network of seismic and tide gauging stations along the south coast of Alaska. Shortly thereafter, in late 1965 and early 1966, the University of Alaska's new seismic laboratory began establishing a network of stations in central Alaska.

Now there are more than 200 short-period seismic stations in Alaska, divided into at least six major networks, and operated by five different groups for a variety of different purposes. A clear need exists to synthesize all of this data on Alaskan earthquakes into one list.

ENHANCED OIL RECOVERY

Principal Investigator: Christine Ehlig-Economides
Dept. of Petroleum Engineering
School of Mineral Industry
University of Alaska
Fairbanks, Alaska 99701

Amount Funded: \$120,000

Alaska owes most of its present and much of its future prosperity to revenues from oil and gas production within the state. While exploration continues on the North Slope and offshore, the ongoing production from fully developed reservoirs in Alaska already provide the U.S. with nearly 20 percent of the total domestic production.

As primary production rates begin to decline and the secondary measures such as gas cap injection or water flooding reach the limits of effectiveness, the Alaskan reserves will be greatly extended through design of appropriate enhanced oil recovery processes.

To aid the design effort, the investigators propose a major, two part research project on enhanced oil recovery in Alaska. The first part will deal with the physical properties of the Alaskan crude oil. The second part, which is not a component of this proposal, will deal with the geological description of the formation properties of Alaskan reservoirs.

NEAR-SHORE BOTTOMFISH MANAGEMENT PROGRAM

Investigators: Lewis Haldorson
University of Alaska
Juneau, Alaska

Alaska Coastal Research, Inc.
Box 368
Langely, Washington 98260

Amount Funded: \$72,710

With the recent trend to very short halibut openings in southeast Alaska, and reduced salmon troll seasons, increasing numbers of fishermen are turning to, or investigating the possibility of fishing previously underutilized resources. Near-shore bottomfish are the first alternative for most of these fishermen. It appears that these previously unexploited fish populations are beginning to be targeted by small boat fishermen who are seeking alternate resources.

Research underway since 1980 has gathered extensive baseline information on important species caught in these fisheries. However, the state in 1981 almost eliminated the bottomfish study program in Alaska. The data gathered remains of relatively little value to the state unless it can be used as the basis for developing effective management plans. The proposed research is designed to complement this research program by developing a monitoring procedure for the inshore aggregation of fishes.

EFFECT OF HYDROCARBONS ON FISH

Principal Investigator: John P. Harrington
Chemistry Department
University of Alaska
Anchorage, Alaska 99501

Amount Funded: \$47,029

This project will help answer any questions on the long term effect that hydrocarbons, especially aromatic and polycyclic aromatic hydrocarbons, have on fish.

The rapid exploration and development of oil potential in Alaska may soon overlap all the richest fishing areas of the state. The investigator plans to obtain dissolved hydrocarbons and raw crude oil from Port Valdez ballast, fractionate it by solvent extraction and test the effects of these fractions on the mutation rate of bacteria and Alaskan fish.

One of the chief values of this project will be to raise the general awareness of interactions between industry and the environment.

STUDY OF WIND CHARACTERISTICS FOR APPLIED WIND POWER

Principal Investigator: Tunis Wentink, Jr.
Professor of Physics
Geophysical Institute
University of Alaska
Fairbanks, Alaska 99701

Amount Funded \$149,408

The objective of the proposal is to provide information leading to the early implementation of wind powered systems as energy supplements for use by the people of Alaska. The work involves the analysis of existing wind data, acquisition of new wind data and transference of the information to the users of wind power.

The research will provide an improved service program for dissemination of wind power information, involving coordination with the University and other extension services and agencies. One improvement in particular will be in servicing specific information requests by private enterprise and state and local governments.

INFLUENCE OF CLIMATIC FLUCTUATION ON PERMAFROST

Principal Investigator: T.E. Osterkamp
Geophysical Institute
University of Alaska
Fairbanks, Alaska 99701

Amount Funded: \$142,733

Permafrost is a common soil condition in Alaska, with about three-fourths of the land area underlain by permanently frozen ground. Long-term needs of understanding the basic permafrost properties and processes and the short-term needs of developing solutions to permafrost detection and engineering problems, require intensive study and a comprehensive approach.

The study will include the monitoring of the thermal regime of the permafrost in Alaska at 15-20 sites. Measurements will be made of the thickness of the active layer and any thawing that may occur at the permafrost table and base, and of the temperature profiles through the permafrost section.

Interpretation and modeling of the temperature profiles will then be carried out to determine the effects of past and present changes in surface temperatures on the permafrost and to predict future changes in the permafrost regime.

SOLAR RADIATION ASSESSMENT

Principal Investigator: Gerd Wendler
Geophysical Institute
University of Alaska
Fairbanks, Alaska 99701

Amount Funded: \$165,964

Before an alternative energy source can be applied intelligently in Alaska, knowledge of how much energy is available from this specific source is essential. There is very little information concerning solar energy. Although a sophisticated system of solar radiation data acquisition is in use at the Geophysical Institute in Fairbanks, most of the data is only for the Fairbanks vicinity.

In order to obtain radiation data from each of the four major climatic regions in the state, substations were established in Kodiak, Anchorage and Barrow, using a limited number of sensors and antiquated data systems. The resultant data from these three stations are incomplete for proper evaluation of solar energy utilization.

The investigators propose to maintain operation of all four radiation stations in Alaska after the Department of Energy support discontinues. The Fairbanks station will operate as it is at the present, but the other three stations will be upgraded by using additional sensors needed for the assessment of solar energy. All data will be reduced and presented in a form directly usable by individuals or agencies within Alaska. The data will be archived and disseminated by the investigators and the State Climatologist at the State Climate Center.

BIOGEOCHEMISTRY OF ARSENIC MINE DRAINAGE

Principal Investigator: Edward J. Brown
Institute of Water Resources
University of Alaska
Fairbanks, Alaska

Amount Funded: \$83,500

The contribution of micro-organisms to the accelerated leaching of arsenic associated with gold mining to groundwater is unclear. The proposed research will study the biogeochemistry of arsenic in both placer and lode gold mining areas in Alaska where arsenic is prevalent.

This research could determine the specific causes for the increased levels of arsenic in streams and groundwater. The results of the study will be used to formulate solutions to water quality problems caused by placer and gold mining (if mining, in fact, is determined to be the cause).

STUDY OF AIRBORNE POLLEN AND SPORES FOR MEDICAL PURPOSES

Principal Investigator: James H. Anderson
Research Associate
Institute of Arctic Biology
University of Alaska
Fairbanks, Alaska 99701

Amount Funded: \$81,341

Many Alaskans suffer with allergies induced by airborne pollen and spores. Alaska is practically unknown "aeropalynologically", and research is needed to help allergic patients and their physicians toward more effective prevention and treatment.

The objectives of this proposal will be to acquire detailed knowledge of the composition and seasonality of the atmospheric pollen and spore flora and to develop a method of predicting significant pollen inducing events.

This proposal is partly for funding to finish analysis of 1978 samples and to analyze the samples from three Durham samplers in 1981. The major portion of the funding is to upgrade, expand and intensify aeropalynological research more adequately to meet medical and scientific needs and criteria in the state.

FATE OF FERTILIZER NITROGEN IN AGRICULTURAL SOILS

Principal Investigator: Stephen Sparrow
Agricultural Experiment Station
University of Alaska
Fairbanks, Alaska 99701

Amount Funded \$191,257

Very little is known about the behavior of nitrogen fertilizer in Alaskan soils. A better understanding of this behavior is needed to enable efficient utilization of applied nitrogen by crops and to minimize potential pollution problems.

The proposed research will study the various transformations and fates of nitrogen fertilizer in Alaskan soils. These include nitrification, immobilization and mineralization, leaching and gaseous loss of nitrogen. The results will be used to make recommendations to farmers and to policy planners on methods of management for best use of nitrogen fertilizer.

The study site will be located on University land at mile 1408, Fairbanks, within the Delta Agricultural Project. A leaching study will also be conducted at the University of Alaska Research Farm, at Fairbanks.

GROWTH RATES IN MUSKOX CALVES

Principal Investigator: Robert G. White
Institute of Arctic Biology
University of Alaska
Fairbanks, Alaska

Amount Funded: \$52,059

Muskox herds reintroduced to Alaska are expanding rapidly and show extremely high population growth rates. This phenomena warrants further study as these muskox may compete for food with caribou, reindeer, and moose.

There are no data on the milk requirements and food conversion efficiency in muskox calves, which is needed to interpret the nutritional basis for differences in growth and reproductive performance of circumpolar muskox populations.

IMPACT OF COMMUNITY PARTICIPATION ON RURAL EDUCATION

Principal Investigator: Gerald A. McBeath
Department of Political Science
University of Alaska
Fairbanks, Alaska

Amount Funded: \$146,332

Alaska lacks information on the extent and degree of community participation and involvement in its schools, as well as what effect such participation has had on students and parents.

This project will describe the range of variation in community activity in rural areas of the state. Field research is proposed in 20 sites with data collection using several methods. Case studies will be formed and compared, and the project will also provide information necessary for the formulation of strategies for effective community participation.

HUMPBACK WHALE SURVEY IN PRINCE WILLIAM SOUND

Principal Investigator: Olga von Ziegesar
North Gulf Oceanic Society
P.O. Box 156
Cordova, Alaska

Amount Funded: \$17,987

The purpose of this research is to photo-document individual humpback whales and determine their number, movements, and activities in Prince William Sound, Alaska.

This information will be used to determine any critical habitats or critical time periods in humpback whale utilization of the area. In addition, data collected will provide a baseline against which future changes can be measured.

ARCTIC ALASKA SOILS DATA BASE

Principal Investigator: K.R. Everett
Ohio State University
Research Foundation
Columbus, Ohio

Amount Funded: \$45,548

A large data pool exists for the characteristics of soils in arctic Alaska, and these data are being added to at an ever increasing rate. At present there is no single source from which to access the existing soils information.

It is the goal of this project to assemble and cross reference existing soils data for arctic Alaska while it is still in a manageable state.

EFFECTIVE TEACHERS IN RURAL ALASKA

Principal Investigator: Judith Kleinfeld
Professor of Psychology
The Institute of Social and Economic Research
University of Alaska
Fairbanks, Alaska 99701

Co-Principal Investigator: Bill McDiamond
Research Associate
The Center for Cross-Cultural Studies
University of Alaska
Fairbanks, Alaska 99701

Amount Funded: \$145,18

The extremely high teacher turnover rate in rural Alaska disrupts the continuity of educational programs, contributing to academic deficiencies for many students. Often these problems are caused by the teachers themselves who cannot cope with a cross-cultural, multi-grade classroom in a different cultural situation, and the rigors of a rural Alaskan lifestyle. Despite the significance of the problem, very little research has been done on the characteristics of teachers who are successful in isolated cross-cultural situations, or with Eskimo and Indian students.

This proposal will examine the characteristics of teachers who are effective in rural native communities. The research will identify the criteria which rural communities use in evaluating the effectiveness of rural teachers. It will also identify the criteria which school administrators and other professional educators use in evaluating teachers in rural settings. Finally, it will describe the characteristics and adaptive strategies of rural teachers who have been considered effective by these groups.

The research target school districts will include some with a high teacher turnover rate. In the high rate districts are: Southwest Region, Northwest Arctic and Kuspuks school districts. The low rate districts are: Lower Yukon, Lake and Peninsula and Yukon Flats school districts.

GENETIC ANALYSIS OF BITING ALASKAN BLACK FLIES

Principal Investigator: Gerald F. Shields
Associate Professor of Zoology
Institute of Arctic Biology
University of Alaska
Fairbanks, Alaska 99501

Amount Funded: \$39,216

An increase in agricultural and livestock production is expected to continue in Alaska. Species of black flies, after emergence, extract blood from a variety of hosts, including man and cattle. In addition, little is known of the deleterious effects of black flies on subsistence resources such as reindeer and caribou. In areas outside of Alaska, these flies have severely reduced productivity through host harassment, and in extreme cases, death has resulted.

The more noxious biters are known as Gnu arcticum and the study will concentrate on this species. Preliminary analyses of the distribution of arcticum indicate that this species reproduces in abundance in the very areas of Alaska in which livestock increases are planned. This particular insect presents a potential threat to the success of the livestock industry in Alaska.

When the studies are completed, control agencies will be provided with information concerning the location and distribution of cattle biting flies in the areas proposed for livestock production, the relative abundance of these taxa in relation to non-biting types and the emergence time at these locations.

EVALUATION OF EMERGENCY TRAUMA TRAINING IN LOGGING CAMPS

IN SOUTHEAST ALASKA

Principal Investigator: Laurel Anderson
Southeast Region EMS Council, Inc.
Sitka, Alaska

Amount Funded: \$24,525

Logging is the most hazardous industry in Alaska. In 1978, accidents and injuries in logging camps were four times the rate of all private sector industries. In 1974, an advanced emergency care course was introduced to two logging camps in Southeast Alaska. Since that time, Emergency Trauma Training (ETT) has been conducted in nine other camps. Reports from independent sources indicate that the training reduces the severity of the injury and the incidence of accidents. This study will determine if these reports are related to the ETT. This will be done by examining Workers' Compensation claims of some logging camps from 1973-1979 and comparing camps that received ETT with camps that did not.

NORTHERN PLANTS DOCUMENTATION CENTER

Principal Investigator: David F. Murray
Institute of Arctic Biology
University of Alaska
Fairbanks, Alaska

Amount Funded: \$39,541

This proposal is for funds to supplement federal and University of Alaska support of a computerized data bank of information on Alaskan plants. These data provide fundamental information required in environmental assessments, land use planning, vegetation mapping, and impact evaluation.

Although the data have been available, their retrieval has not been practical until the development of appropriate computer programs. These project funds will be used to expand the master file.

STUDIES OF ALASKAN DULSE (Marine red algae)

Principal Investigators: John W. Chandler
Robert J. Ellis
Natasha I. Calvin
Marine Botanicals
Auke Bay, Alaska

Amount Funded: \$75,000

Preliminary laboratory studies indicate that two species of seaweed found primarily in southeast Alaska are effective against herpes virus. Alaskan Dulse is the name given these two species by their discoverers.

Prior to determination of the abundance of seaweed in Alaska the medical effectiveness must be researched. This project will analyze the properties of the Dulse and explore the medical implications for treatment of herpes infection through topical application of Dulse.

ALASKAN TEPHROCHRONOLOGY PROJECT

Principal Investigator: Robert Thorson
Assistant Professor of Geology
Geology/Geophysics Department
University of Alaska
Fairbanks, Alaska 99701

Amount Funded: \$121,365

Tephrochronology is the study of volcanic deposits or tephra (volcanic ash) which results from explosive eruptive events. Geologists in this discipline attempt to determine the characteristics, age, source and distribution of volcanic ash, so that volcanic hazards can be properly assessed. Compiling this information is critical for understanding the regional hazards associated with explosive volcanic events.

This proposal will fund the organization and completion of an Alaskan Tephrochronology Project at the University of Alaska Museum. The purpose of the project is to define and facilitate the study of tephra layers throughout the state. The objectives will be to establish a reference collection and data file on Alaskan tephra; to coordinate future tephrochronology research.

The end result of the two-year project will be the first comprehensive view of the entire volcanic ash sequence in Alaska. Such an overview will be vitally important in identifying volcanic hazards and enhancing the safety and well-being of the state's residents.

COASTAL FLOODING BY STORM SURGES & OBJECTIVE FORECASTING PROCEDURES

Principal Investigator: James L. Wise
Arctic Environmental Information
& Data Center
University of Alaska
707 "A" Street
Anchorage, Alaska 99501

Amount Funded: \$57,500

Coastal flooding from storm surges is a real hazard to communities along the Bering, Chuckchi, and Beaufort Sea coasts. The project will gather storm surge occurrence data, then work with the National Weather Service and a storm surge modeling expert to:

- 1) prepare a climatology of storm surges;
- 2) develop manual objective forecast procedures; and
- 3) develop an automated objective forecast procedure.

YUKON-KUSKOKWIM COASTAL COMMUNITY HARVEST DISRUPTION STUDY

Principal Investigator: Ann Fienup-Riordan
325 East Manor Street
Anchorage, Alaska 99501

Amount Funded: \$79,888.

The study will provide socioeconomic and sociocultural parameters that can be used to evaluate the nature and extent of potential resource conflicts on coastal Alaskan communities, should uplands or offshore oil and gas activities create an environmental disturbance.

Research will include the identification and assessment of the economic, social and cultural ramifications of possible renewable resource harvest disruption on residents of Scammon Bay, adjacent communities, and the region as a whole. Disruptions could include effects of offshore structures, tanker movements, noise, human disturbances, potential oil spills and other occurrences.

SIXTY SECONDS OF SCIENCE

A SERIES OF STATEWIDE MONTHLY RADIO PROGRAMS

Principal Investigator: Nan E. Elliott
Arctic Environmental Information and Data Center
University of Alaska
Anchorage, Alaska 99501

Amount Funded: \$62,006

"Sixty Seconds of Science", a statewide monthly radio program, was developed by the Arctic Environmental Information and Data Center in 1980 through a grant from the National Science Foundation.

The goal of the project is to reach the nonscientific audience and inform it of science activity in Alaska. Ten 60-second programs will be produced each month. The programs are aired by 85 percent of the commercial and public radio stations in the state. In 1981, in its first year, "Sixty Seconds of Science" won a first-place award from the Alaska Press Club.

UNDER-ICE NAVIGATION BY SEALS

Principal Investigator: Robert Elsner
Institute of Marine Science
University of Alaska
Fairbanks, Alaska 99701

Amount Funded: \$35,631

The objective of this study is an experimental examination of the under-ice orientation and navigation capabilities of the Bering Sea spotted seal. It will investigate the possible sensory disturbances arising from ambient noise levels and environmental disturbances which are anticipated to take place in connection with petroleum exploration in Alaskan waters seasonally covered with sea ice.

A series of experiments will be performed with captive spotted seals. The study will take place in a large, flooded industrial gravel pit during the winter to simulate under-ice low visibility conditions while maintaining control over the environment.

REMOVAL PROCESSES OF AIR POLLUTION PARTICLES BY ICE FOG CRYSTALS

Principal Investigator: Takeshi Ohtake
Geophysical Institute
University of Alaska
Fairbanks, Alaska 99701

Amount Funded: \$118,816

Air pollution in Fairbanks during the winter months manifests itself primarily as ice fog. Researchers have cautioned that the city might experience dangerously high levels of air pollution with increasing population and industrial development.

However, a high possibility of removal of air pollution particulates by sedimentating ice fog crystals has been demonstrated. Chemical analyses of ice fog precipitation collected in the Fairbanks area suggest that the pollution particulates are scavenged by the ice fog crystals. If removal of air pollution by ice fog is verified, more ice fog might be preferable because the ice fog may be less harmful than air pollution.

This possible cleansing effect of air pollution particles will be studied in Fairbanks. The mechanism of the scavenging effect of ice fog crystals will be examined by use of electron microscope techniques. The research objectives of this study will be: to obtain current size and number distributions of ice fog crystals and aerosols in Fairbanks and its vicinity; to evaluate the degree of the cleansing effect by ice fog crystals in a subarctic polluted urban atmosphere; and to examine the mechanism of artificially enhancing such a possible scavenging effect by small ice fog crystals.

STUDY OF IMPLEMENTING ALASKA'S BILINGUAL EDUCATION POLICY

Principal Investigator: Ramona N. Suestopka-Duerre
University of Alaska
Arctic Environmental Information and Data Center
Anchorage, Alaska

Amount Funded: \$23,710

The study will analyze the implementation of Alaska's bilingual education policy in the Lower Kuskokwim School District. The intent of the research will be to pinpoint problems, suggest reasons for the problems and offer suggestions for improvement in the district's bilingual education programs. The research will include examination of documents pertinent to the programs under study, observation, and interviews. It will also examine the reasons for the increased difficulty in determining the impact of education policies from one program to another and why a single policy produces varying results in various program locations.

ARCTIC RESEARCH SHIP DESIGN (Phase III)

Principal Investigator: Robert Elsner
Institute of Marine Science
Fairbanks, Alaska

Amount Funded: \$161,933

Earlier design work for an arctic research ship established the requirements for national polar research vessel operations in terms of geographic regions, environmental conditions and scientific capabilities. The design envisages a ship having characteristics of 225' water line length, 2900 tons displacement, twin rudder and diesel propulsion.

This proposal is to continue the design effort to solve technical problems which remain and which require resolution before further development work can begin. These problems concern sea ice resistance and propulsion and include design improvements such as: modification of hull lines; diesel, reduction gear, nozzled, variable pitch propeller propulsion, and reduction of frictional resistance in ice by air-water lubrication.

A model will be constructed suitable for the installation of self-propulsion equipment and testing. Model tests in ice will be performed at various ice thicknesses to determine the resistance of the ship and to observe the flow of ice around the hull. Modification of hull lines and lubrication techniques will be studied for effectiveness in reducing ice compression, resistance, and ice flow under the hull.



THE ALASKA COUNCIL ON SCIENCE AND TECHNOLOGY

November 30, 1982

Jerry Wilkerson
Director
Legislative Budget & Audit
Alaska State Legislature
Juneau, Alaska 99811

RECEIVED
DEC 01 1982
LEGISLATIVE
AUDIT

RE: Interim Letter #1, Carol Carroll, Auditor

Dear Mr. Wilkerson:

The Alaska Council on Science and Technology (ACST) appreciates the receipt of your interim audit findings dated November 8, 1982. In our meeting of November 17-18 the Council reviewed your findings and offers the following comments for your consideration.

Generally speaking, we agree with some of your substantive conclusions but question the rationale from which they are derived. In other cases we believe either the legislative history or the actual statute governing ACST operations has been misconstrued, at least in part.

As a place of beginning it is of basic importance to examine your statements: a) "The primary legislative goals were to coordinate and centralize research information in order to ----" (page 1, last paragraph) and b) several statements implying that the Council is mandated to "coordinate" state funded research, per se. An examination of the statute indicates that the word "coordinate" or its derivatives is used only in the following statutory references:

1. In Section 1. LEGISLATIVE FINDINGS "(3) expenditures are not adequately coordinated in the state to achieve the highest and best use of research dollars" (emphasis added).
2. In Section 44.19.182 (c) "8. coordinate its data and information needs with other research organizations in order to avoid unnecessary duplication;" (emphasis added).

By way of additional comment on the "coordination" role, it is well to be aware that an early draft of the ACST bill drew particularly strong opposition from state agency and university leaders. The context of this draft was that "state money may not be spent for research projects, unless, before commencing the research, the agency or person responsible for conducting the research submits to the council for its review and comment a scope of work proposal----". Consequently, the legislature rejected ear'v the idea that the Council should "coordinate" research through any measure of review or sanction.

Broadly speaking, the legislative background of the establishing statute led the Council to consider its general mandates as being to survey research needs, to recommend research priorities, to award research grants and to provide advice to the governor and legislature upon request. In these general mandates, the Council asserts that it has, in fact, derived its research needs statements and data and information needs in a "coordinated" fashion with other research organizations, state and federal agencies, and the private sector. The proof of this statement is twofold: a) the Council drew expert membership for all its research needs committees from those agencies having cognizance and from involved university and private sector research or management organizations. (By this means coordination of research needs assessment by the Council was definitely achieved.); b) informational needs of ACST have also involved a large interagency and interorganizational coordinative network including particular relationship with the information transfer expertise of the state, federal and university library systems, the Arctic Environmental Information and Data Center (AEIDC), and the federal-state interagency Committee on Natural Resource Information Management (CONRIM); and c) in addition to meeting the informational needs of the Council itself (the statutory mandate), ACST has also vigorously supported the information transfer and dissemination function through grants, publications, and the support of numerous conferences. All of these contacts and activities, we believe, belie your comment that, "interaction with state agencies has been limited".

Much of your interim report dwells on your interpretation that the Council has a mandate to coordinate statewide research. This assumption, as earlier pointed out, has no statutory basis. Nevertheless, further comment is still appropriate, particularly on your conclusion drawn from questionnaires, that "the Council has had little effect on State research programs". Through our research needs reports, activities concerned with U.S. Arctic and Alaska science policy and legislative committee contacts we have had direct impact on several state research programs, including the following examples:

- * The seismology program of the Division of Geological and Geophysical Surveys of DNR;
- * The development of programs within ADF&G for the economic appraisal of fish and wildlife resources;
- * The establishment of the Alaska Climate Center within the Arctic Environmental Information and Data Center, University of Alaska.
- * The establishment of the airport weather program in Alaska rural villages within the DOTPF;

November 30, 1982

Page 3

- * The resolution of the rural village smoke/fire safety program within the Department of Public Safety;
- * The acceleration of mineral mapping programs within DGGs;
- * The general research programs conducted by the University of Alaska notably in the biological, geological, agricultural, atmospheric sciences;

and other examples of longer term impact such as the very large influence on public health research, both state and national.

Letters of testimony on these examples can be made available.

The implication of state sponsored research duplication also requires comment. The ACST, after considerable investigation, is unaware of any specific cases of research duplication, nor does your audit report identify any. Moreover, in scientific inquiry duplication is not necessarily bad. Redundant research is practiced in all fields of scientific or engineering endeavors as a means of conclusion verification. It is not bad, per se. More to the point of duplication in state government may be the practice whereby more than one agency investigates or analyzes a particular problem, e.g. the current studies of the so-called "All Alaska gas pipeline". Nevertheless, here again, there may be valid state purposes served by duplicative efforts.

Finally, your comment under A3, page 2, is, in our opinion, particularly lacking in comprehension. This commentary makes two points. They are:

1. That the Council has been "ineffective in gathering research available to them through departmental budget documents, session laws, and various reports required by the legislature."; and
2. That the Council has limited itself to coordination of its own research budget----. When compared with the University of Alaska research budget it is clear that the Council has had little statewide effect on research coordination or on reduction of unnecessary duplication".

On the first point: germane session laws and legislative reports are reviewed by Council members and staff. Departmental budget documents, based upon our experience, are worthless as sources of information on research. A much greater comprehension of research activity can be ascertained from other sources previously mentioned. On the second point: our position is that the size of current budgets available to any organization is unrelated to either "research coordination" or reduction of unnecessary duplication. In discussion with you, we would be pleased

November 30, 1982

Page 4

to point out the general sources of approximately 200 million dollars of research expenditures in Alaska, but the issue of coordination is primarily related not to the totality or share of these expenditures, but rather to specific problems and the means whereby they may be solved. It is with regard to achieving coordinated mechanisms for solving research problems that the Council members have spent so much effort on the introduction and passage of S.1562, the Arctic Research and Policy Act, in the Congress and also on the introduction in the upcoming state legislature of an Alaska science policy resolution.

In summary, the Council believes your first interim finding that ACST "has been ineffective in coordinating statewide research information" is inappropriate on the grounds that you have misinterpreted the statute and legislative history and have not fully comprehended the "coordinating" mechanisms which, on the record, the Council has utilized to meet its statutory requirements and service to the State generally.

Your second interim finding B. (page 2) was that "the Council has not complied with the intent of AS44-.21.242 (c) 3 requiring comment on significant research activities funded by the state during the preceding year" (emphasis added). Your narrative with this finding makes three points: a) the implication that comment upon significant research was not included in our annual report; b) that the Council lacks the knowledge on the type and cost of research funded by state agencies; and c) that this alleged lack of our knowledge is due to the appropriation of research funds to agencies without requiring coordination through the Council or reports to the Council. The Council's response to this interim finding is as follows:

1. In our 1981 Annual Report (pages 8-14) the Council made specific comment on areas of state research, or the lack thereof, which in our view were most significant.

2. The Council absolutely rejects the notion that it is lacking in knowledge on the type of research pursued by state agencies, including the University of Alaska. Through its interdisciplinary membership, the involvement of state and university scientific personnel in Council affairs and reports and particularly close relationships with AEIDC and CONRIM, the Council as a body has a greater and broader understanding of state funded research as pertains to subject, type, and who is doing research than any other group of people in Alaska. We do, however, acknowledge that only partial information is available to the Council (or for that matter, anyone) on the costs of such research. On this point we agree that there is no requirement for state or university reporting on this subject. Thus, the only cost data available are furnished to the Current Research Profile (CRP) maintained by AEIDC through a voluntary response questionnaire system. A basic problem in this regard is that while cost information on particularly designated

projects sometimes appears in budgetary documents, it is often augmented with other funds from various agency sources. Furthermore, research funded from operational budgets is often undesignated, except in the CRP, after the fact, and again total costs from one or more sources may not be reported.

In summary, there is a dichotomy between knowledge of who is conducting research on what subjects and how much it may cost.

On page 3 of your interim report, under C., you raise the review of State research needs. It is the view of the Council that research needs in functional areas of activity (i.e., transportation, living resources, etc.) can be prioritized. This we have endeavored to do at minimum costs, a process largely involving the voluntary committee apparatus of cognizant experts. The Council is of the opinion that scientific or engineering expertise cannot, nor is it appropriate to, prioritize research needs between functional or subject areas because societal aspirations between, e.g. health needs research on one hand or natural hazard research on another, can only be prioritized in the political arena. Science and engineering expertise can properly indicate the gaps of knowledge needed for research attention to solve certain problems. The determination of society's priority to solve particular problems must be a reflection of the relative worth of the endeavor as determined by representatives of the people in the political process.

Point D (page 3) of your interim report is, we suggest, not wholly or directly related to the Council's administration of research grants. The administration of research grants by the Council began as a legislative response to our early research needs reports. Research funds were not initially requested by the Council for Council administration. Rather, it was perceived by the legislature that the Council could perform this task most effectively. A technique involving nationally accepted peer review processes was initiated and received national recognition in Science as a model of efficient and qualitative review of research proposals. As a deliberative body with scant staff the Council turned to the peer review process in order to evaluate the efficacy of scientific or engineering propositions advanced for research funding. Early on, during the receipt of proposals for research funding, several Council members went on the record over the problem of research advantage to University of Alaska proposers over the private or governmental sectors. As you are aware, University research organizations are only funded between 25 and 30 percent by direct state appropriation, although the total authorized appropriation by the legislature is 100 percent. Thus, when University research is authorized at about 48 million dollars by the legislature only about 14 million dollars represent direct state fiscal outlays of money. The remaining 34 million dollars authorized is expected to come from federal, state, and private grants and contracts. This situation forces University proposers to be highly experienced and capable competitors for research funds. Indeed by peer review standards their proposals to the

November 30, 1982

Page 6

Council were generally superior to others received. This of course resulted in the high percentage of Council grant awards to University researchers.

The next part of your discussion on research grants involves University overhead charges. As you should realize, overhead charges in the University accounting procedure are real costs of performing research. They greatly transcend "administrative" costs. University overheads conform to audits conducted under federal regulations to all universities receiving federal dollars. Internal audits by the University and the state are cognizant of this fact, and those responsible in the University administration and the State Department of Administration are aware of this overhead audit procedure. There simply is no relationship between University "overhead" charges and the administrative costs of less than 10 percent experienced by the Council in the execution of research grant awards. The Council takes the position that a 10 percent cost for the processing of grant or contract awards will compare favorably with any similar state or federal activity.

Your point E (page 4) again, in our view, illustrates certain misconceptions. You state that "the primary objectives of the Council are duplicative of functions presently performed by AEIDC. This is not the case. As indicated earlier, the Council's primary functions are the ascertainment of research needs, the recommendation of research priorities, the awarding of research grant funds and the providing of scientific or technological advice to the executive or legislative branches upon request.

AEIDC's primary missions are scientific and technological information transfer and referral, information dissemination, and the execution of interdisciplinary problem solving research and investigations, primarily but not wholly in developing areas of new science and technology.

The Council has coordinated its informational needs with AEIDC and has cooperatively utilized their resources in information transfer and dissemination. AEIDC has no primary objectives in determining or prioritizing state research needs, commenting upon state policy in scientific or technological matters, or advising either the executive or legislative branches on state research programs. While AEIDC does have a major role in channeling research information to various public, governmental, and private sector users, AEIDC does not aspire to, nor is it equipped, as a University organization, to "coordinate" statewide research, per se.

November 30, 1982

Page 7

From the foregoing comments the Council asserts that your interim report conclusions cannot be substantiated in logic, by the record, or by statutory reference. In summary, the Council has not coordinated State funded research on an a priori basis because it is not mandated to do so, nor was it ever conceived that it do so. Research grants of the Council, we believe, have been efficiently administered. The Council's primary functions are not duplicative of AEIDC.

Now, having, we believe, refuted most of your interim report analysis within this response, the Council nevertheless can agree with some of your conclusions and recommendations. We direct the following commentary towards your recommendations since we believe that the Alaska apparatus concerned with state science and technology policy and the administration of research grants can be improved.

Commentary on Recommendation No. 1

Leaving aside our rejection of your rationale on the Council's information base, the Council does believe it is a salutary recommendation that all research contracted or performed by state agencies be reported to a central informational entity. The Council could be this entity or the existing arrangements between the Council and AEIDC could be strengthened or any other appropriate unit of state government, including AEIDC, could be so designated.

Commentary on Recommendation No. 2

The Council believes it has, subject to the limitations imposed by staff resources, met its statutory obligations. In order to be effective the Council requires a much closer relationship to both the Executive and Legislative branches on policy issues of concern. The Council can respond in research priorities to specific policy issues. It cannot prioritize research needs across policy issues which are a reflection of societal aspirations.

Commentary on Recommendation No. 3

November 30, 1982

Page 8

Again, setting aside the rationale for this recommendation, the Council agrees that the granting of research funds by a deliberative body may not be appropriate. Indeed, if you will go back into the legislative history of the Council you will find that the three rather disparate functions of the Council generally, i.e., policy advice, research funding, and technical subject problem analysis, were first proposed in three distinct bodies. These were: governmental policy assistance through a Council apparatus such as ACST; research funding through a line organization paralleling national and other state entities, in effect an Alaska Science Foundation; and technological subject expertise application through a private sector organization such as the newly formed Alaska Academy of Engineering and Sciences which could assemble expertise through Academy committees. The experience of the past four years reinforces the efficacy of this original conception.

Commentary on Recommendation No. 4

We agree and have endeavored to do so.

Other Recommendations to be Considered

The Council is in effect a voluntary organization. Members have devoted a great deal of their time to its deliberations. The staff is very small and is more administratively than scientifically oriented. An expansion of staff resources may be a consideration of merit. We should discuss this with you.

By way of conclusion to this response, the Council is attaching its own analysis of the questionnaire results it received from you. The analysis was done by Council member Neil Davis. We hope that this analysis may be useful to you.

Despite our disagreements with you on several points we have offered our comments in a constructive sense and hope we can share with you further dialogue eliminating our differences and which will be reflective of both the Council's strengths and weaknesses. Thank you for the opportunity to respond to your report.

Sincerely,

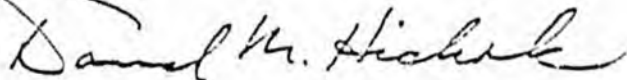

David M. Hickok
Chairman

DMH/pp

Enclosure

I

Legislature of the State of Alaska

Testimony of
Dr. Edward Wenk, Jr.

It is quite a privilege to testify on new legislation regarding the Alaska Council of Science and Technology. In my view, this proposition may be one of the most crucial to come before this session. By updating an important aid to state decision making, continuity of the ACST would represent a small investment today that should pay off handsomely tomorrow --- providing sharp and objective information on Alaska's opportunities and problems so as to foster development with the least disappointments or unwitting economic and social costs. I hope that these brief remarks may be helpful in your deliberations.

By way of introduction, a word or two about your witness. Over the last 24 years, I have been a participant in or analyst of advisory apparatus related to the making of technology-intensive policy. Although trained as an engineer and engaged as a practitioner for 18 years, I became the first science advisor to the U.S. Congress in 1959, then served on the science policy staffs of Presidents Kennedy, Johnson and Nixon. In 1970, I was appointed to the faculty at the University of Washington, where I have taught, conducted research, and continued in advisory capacities, especially to the Congress.

Over this last decade, I have periodically visited Alaska where I learned firsthand about its people, its economy, its challenges and its dilemmas. I soon understood why Alaska's future is a special case so that whatever steps are taken in science and technology policy must be carefully matched with the unique characteristics of geography, economy, history, hopes and dreams of its citizens.

As legislators, you have a powerful vantage point on Alaska's agenda so much of which depends on science and technology. These issues and corresponding initiatives, to name just a few, would:

- Increase efficiency, economy and productivity in state government by strengthening information resources, communication linkages and use of technological aids;
- Foster development of Alaska's natural resources, by understanding their distribution, richness and accessibility, by enhancing techniques of management in the public interest to assure a competitive position in world markets;

- Evaluate the future supply and demand of energy, state and global, considering indigenous sources of hydroelectricity and natural gas, their transportation and distribution;
- Provide new opportunities for employment through technological innovation, linking university R and D with industrial and state requirements, attracting diversified industry, facilitating capital formation, promoting long term investments and stimulating economic vitality in rural areas;
- Consider new rail networks that would improve interior transport, considering geology, climate and state of the art of hardware;
- Evaluate the impact of new technologies unfolding in the lower 48 to map dependencies and constraints that may influence the future of the state;
- Expand knowledge of high latitude phenomena, for example of electromagnetic effects that may impair pipelines, disrupt electrical power or radio transmissions, and of frozen soil that must be considered in construction or maintenance of highways, large buildings, railroads, and underground utilities;
- Strengthen meteorological reporting and forecasting as it affects agricultural development, stream flow, and hydroelectric capacity, glacial behavior, outdoor recreation, aviation and maritime safety, etc.;
- Extend capabilities for health maintenance and disease prevention so as to prolong and improve quality of life and to contain rising costs of medical care;
- Meet needs of a growing population for highways, water supply, sewerage, fire and police protection;
- Help manage state funding of research and development, which is a greater proportion of the total conducted in Alaska than in any other, to assure its focus on interests of the state, promote high standards in its conduct, and the effective utilization of products.

Although these examples cover a wide range of topics, they reveal significant common features:

- All these key decisions, consistent with Alaska's Constitution, are matters of public policy,
- Options depend critically on research results from natural and social sciences and engineering, and on alert inquiry as to future technological and social developments,
- Substantial public investments are involved,
- Issues are both technically and institutionally complex and require heightened initiative for public understanding and acceptance,
- Consequences of error are likely to be costly, politically difficult to correct, ecologically irreversible, or marked by shortfall in goal achievement,
- Implementation requires balanced partnership between public and private sectors,
- Public responsibilities for implementation, monitoring, or regulation cross agency boundaries so as to require an unusual degree of coordination,
- The past no longer provides a guide for the future, thus requiring new levels of foresight and impact analysis.

Put another way, these technology-laden issues involve high stakes for Alaska. Moreover, their satisfactory resolution depends on a base of sound information and analysis, and on keen public management. Because of Alaska's special situation, research conducted elsewhere may not suffice.

All of which adds up to the need for Alaska to equip itself with technical advisory apparatus that can provide essential facts and objective interpretations, focused on policy questions, prompt, free of advocacy, future oriented, drawing on a wide range of expertise, clearly and concisely presented. For only after the crucial data base is developed can options be examined and rational choices made that reflect economic, social, legal and political considerations that must be blended in democratic process.

In short, we find that both policies and policymaking that depend on science and technology are substantially different from others. So what do we do?

It is here that such steps may be easiest visualized with a nautical metaphor. Science advisory apparatus is like having a

navigator on a ship's bridge. It's function is an adjunct to that of the captain; it does not replace the crew in the engine room tasked with smooth operations. Navigation involves defining a course to reach a distant and future destination, with a careful watch for obstacles and hazards--early warning of storms, other vessels, reefs--utilizing all available charts, radio, radar and electronic location devices. Otherwise, if these functions are carried out by the ship operator, they are in competition for time and attention, may be terribly distracting--like running from wheel to radar scope--or they may be entirely neglected, with increased risk of collision, damage, delay or failure to achieve goals.

To strengthen the policy making capacity of the state, various instruments are available:

- Modify and strengthen the role for ACST,
- Expand roles of other governmental apparatus,
- reinforce functions in existing staff agencies,
- create a small specialized staff,
- appoint ad hoc advisory committees,
- use private consultants,
- develop systematic citizen consultation.

In considering relative merits of alternatives, and in recognizing that effective functioning may involve several in concert and not just one the following criteria should be considered. The unit should:

- facilitate role of governor as Chief Executive,
- demonstrate credibility and freedom from advocacy,
- assure access to diversity of expertise and of data banks,
- display low cost and structural simplicity,
- impart long range perspective and foresight capacity,
- respond with fast reaction time when needed,
- provide balanced representation of various disciplines and professions,
- demonstrate familiarity with policy process,
- foster interagency coordination and articulate with bodies

at other governmental levels,

- communicate effectively in and outside of government,
- be backed by legislative mandate.

As an aside, while the federal experience is not directly applicable, it may be instructive because exactly the same types of policy predicaments had to be met. Beginning in 1957, the incumbent President and his successors created and utilized four interrelated instruments:

- an advisory committee of outsiders,
- an advisory committee of insiders,
- a science advisor directly on the White House Staff,
- and a small specialized staff office.

With different administrations, these units have undergone major changes to strengthen or to divest tasks, depending upon wishes of the Chief Executive; but except for a 1973-76 hiatus, core functions have continued now for 25 years.

Congress, too, has acted. In 1958, it created a post of science advisor in the Legislative Reference Service, Later, they expanded it to a diversified staff of experts; then in 1972 created an entirely separate Office of Technology Assessment by legislation. Also about 1977, it authorized a science policy unit in the GAO.

States have also established analogous advisory apparatus. They are highly varied; they change in structure and style with new administrations; they range widely in mission and effectiveness. Most have a role in economic development, and these are being reexamined and revitalized as most states respond to the seduction of the hi-tech frontier. The National Governors Association has completed three studies in this area, treating prospects and comparative mechanisms.

To return to Alaska, as was said before, whatever is established here should be custom designed for the State's special needs and situation. As a first step, I strongly support new legislation in relation to the Alaska Council on Science and Technology.

Such a measure should focus more on a policy advisory role and less on managing grants; its mission should reflect:

- the need for acquiring and interpreting technical information in SandT policymaking,

- the potential of scientific and technological research in Alaska's future,
- the obligation to spend public research funds prudently and without unnecessary duplication,
- the benefit of effective information transfer,
- the requirement for central integration of research results,
- the capacity to look ahead and build a future orientation into the advisory function.

I also believe it essential to clarify the organizational arrangements by establishing the ACST in the Office of the Governor. This erases existing ambiguity as to structure, and best assures effective utilization and communication of this resource by linkage between advisor and advisee. Additionally, roles and missions of ACST should be spelled out to meet general criteria for functioning that I listed previously. And finally, the bill should contain an action-forcing provision through a requirement for a biannual report, dealing with the state of SandT, issues deserving research, recommendations for additional research and a summary of significant accomplishments.

In summary, this proposal is derived from what I perceive as needs of the state; it meets a test of soundness, using the criteria for such advisory apparatus. Finally, it would be built on an existing body that, while having a different scope and direction, has a track record of accomplishment that should reduce uncertainties as to performance if it were an entirely new entity. For the ACST has earned recognition and praise in a national scientific journal, almost unprecedented in activities of this kind.

What is important to your deliberations is that this proposal has a high prospect of success. It does mean that the members of the ACST will have a very demanding challenge ahead. But in my discussions with them, they appeared to share objectives and possible changes in legislative mandate that I have repeated here. This step might also correct what seemed to be substantial underutilization by the preceding administration.

I do not believe that this is the last word on what the state may ultimately decide is necessary to fulfill its opportunities involving science and technology. But in my judgment, it is the best possible first step.

J

Testimony of Mr. David Hickok, Chairman, Alaska Council on Science
and Technology before the joint Senate and House State Affairs
Committee-Alaska State Legislature

Mr. Chairman, my name is David Hickok, the current chairman of ACST. With me is Chris Noah, Executive Director to the Council and Dr. Edward Wenk.

For four years we have been involved with an experiment unique to Alaska government experience. An experiment which has involved an extremely high level of volunteer participation and commitment from individuals within the Alaskan engineering and science community. This volunteer effort has been made primarily to make available Alaskan expertise in the sciences and engineering to the legislature and the executive branch as they considered policies and programs requiring such advisory input. Additionally, the Council has prepared research needs reports on subjects applicable to state interests, disseminated science and engineering information on a variety of subjects and in a variety of media and administered grant funds for the support of technology and research grant programs established by the legislature and given to the Council for administration.

Like many experiments our experience has been only partly successful. But we have learned something of both the strengths and weaknesses of a science organization in and for Alaska. I, and the members of the Council welcome this hearing and a candid discussion of the Council's record together with an evaluation of its responsibilities and duties. Since inception we have been engaged in our own self analysis but particularly over the past 1-1/2 years have sought better approaches or ways to alleviate the deficiencies in the ACST structure which we have observed. We brought three distinguished men of science in Alaskan and ocean affairs--Drs. George Rogers, Joseph Fitzgerald and Edward Wenk in to assist us in this evaluation. Dr. Wenk is here today to offer some observations from his lengthy experience in federal science and other state organizations.

With that introduction aside I'd like to briefly summarize some salient points of our own self-analyses. Where we are weak, where we are strong and why.

1. The Councils' authorizing legislation provided for an organizational relationship to both the governor and the legislature. This dichotomy of responsibility to both branches is perhaps the reason why neither has used the broad expertise available through the Council - extant in hundreds of Alaskan scientists and engineers available to assist government in appropriate ways -- to the extent possible.

Even so the legislature and the governor have called upon the Council for advice on numerous and various matters. The legislature has used the Council much more than the past executive branch with particular contacts involving several legislative committees: agriculture, telecommunications, natural resources and state affairs. As you will recall it was the Council who first furnished the legislature through this committee information on the impacts of federal budgetary cutbacks.

The authorizing legislation for the Council called for its placement within the Office of the Governor. However, we were never really welcomed there in the past administration and were transferred first to DEC and later to Administration by executive order.

2. Patterned after the federal experience in science organizations the 1979 draft legislation originally called for three separate entities: an advisory body to the executive branch on policy matters involving science and technology; the chartering of an independent private sector organization - e.g. Alaska Academy of Engineering and Sciences;

and, a third organization to grant funds for the support of scientific and technological research applicable to solving state needs and problems.

During the legislative process all three of these above functions were combined in the ACST. Experience has shown that this was a mistake. A small (seven person) volunteer Council simply cannot perform in both the policy advisory function and the granting of support funds for science and technology.

3. Experience has shown that the membership (7) is too small to effectively represent the expertise necessary to consider the range of scientific and engineering issues brought before the Council. Even though we have a rapid response system at hand to involve hundreds of diverse experts we are hindered in the deliberative and voting process. At least two more members from the private sector would make for a more effective operation.
4. Particularly difficult and time consuming for the Council has been the granting of funds for Northern Technology and Applied Research. In part the criteria for these grants have been vague in the legislation, but more importantly it is extremely difficult for a deliberative body, representing different scientific or engineering disciplines and interests to vote on the propriety of a broad spectrum of research proposals -- even though well screened by reviewing experts prior to Council vote. Incidentally, this review process itself has been most effective scientifically and financially and has been applauded nationally in SCIENCE magazine.

Comments:

Take Away

Grant Authority

5. Despite some of these difficulties we have produced, in our view, with only volunteer help--a rather impressive record of research needs reports, support of meetings and conferences, and dissemination of information in a variety of media: publications, radio and T.V.
6. On the subject of research needs reports and their prioritization we have only made priorities within each subject or function. We have not felt it appropriate to prioritize between research needs in health vs agriculture or natural resources vs transportation, etc. Instead we have held that this prioritization between functions was a matter for elected representatives. Even so if asked our opinion we would have responded.
7. Similarly we have been criticized for not coordinating all science in Alaska. In response to this we have pointed out that the legislative history for the ACST specifically said not to do so, and in any event it would be a mistake to put the Council in a "big brother" role for all Alaska science. Instead, we have pursued the goal of improved coordination in research through indirect means of workshops, conferences and information exchange. In this way--ie communications and involvement--coordination of state interests on many subjects has been achieved.
8. Finally, I would like to point out that we believe it has been in the policy area that the Council has been particularly effective and in an important sense. We have sought the development of research partnerships between the federal government, the state government, universities and private industry. To this end we wrote the report

U.S. Arctic Science Policy, assisted Senator Murkowski in the drafting of his legislation, the Arctic Research and Policy Act, formulated the state's position on this legislation and influenced the national scientific community to support its enactment in the U.S. Congress.

At this point in time the future of this legislation is our greatest concern and highest priority. We feel most strongly that if state and national goals in resource development, human health, environmental protection and national defense are to be achieved in the U.S. Arctic--Alaska and adjacent waters, then the combined forces of science and engineering expertise from government, from academia and private industry must work cooperatively in the greatest partnership possible.

What you decide to be the fate of the ACST or a similar science body in Alaska will have a direct effect on this effort. Unless Alaska continues an interest in science policy and research planning the United States Congress is unlikely to do so.

Thank you for this opportunity to appear before you I'd be pleased to answer any questions.