

H B

267

BILL SHEFFIELD, GOVERNOR

DEPARTMENT OF NATURAL RESOURCES

DIVISION OF PARKS AND OUTDOOR RECREATION

February 19, 1985

Re: Legislation for Campground Fees

225A CORDOVA STREET
ANCHORAGE, ALASKA 99501
PHONE (907) 276-2653

MAILING ADDRESS
POUCH 7001
ANCHORAGE, ALASKA 99510

The Honorable Bettye Fahrenkamp
Alaska State Legislature
Senate
Pouch V
Juneau, Alaska 99811

Dear Senator Fahrenkamp:

We recently discussed the concept of generating additional revenue for the state by charging fees for the use of state park campgrounds in Alaska. I'm hoping to see a bill introduced into this year's legislative session to authorize state park campground fees. My staff and I have compiled some facts, figures, and projections which I'd like to share with you.

The History of Fees in Public Campgrounds

The federal government began collecting fees in national parks over 50 years ago. Today, Alaska is the only state to not charge for the use of recreational facilities. Of the country's 50 state park systems, only Alaska has no campsite fee program. Here in Alaska, the U.S. Forest Service, National Park Service, U.S. Fish and Wildlife Service and Municipal campgrounds all charge fees for camping. And, of course, private campgrounds charge.

In 1976, there was a \$10.00 annual entrance fee established in the Alaska State Park System. This program was terminated two years later by legislation dealing with motor vehicles [AS 28.10.411(e)] which stated that any vehicle with an Alaskan license plate need not pay State Park fees. To have a campsite fee program in Alaska's 100 state parks will require legislation.

Why Should We Charge Fees Again?

In a few words -- declining revenues and increasing demands. In 1982, there were 2.2 million visitors to our state park system; in 1983, 4.3 million; and last year, about 5 million! Information from other agencies charging fees shows that people desire well-developed, well-maintained camping facilities and they are willing to pay for them. Managers have also found a decrease in vandalism and a number of positive management spin-offs which occur when campsite fees are charged. Although government-operated campgrounds are seldom fully self-supporting, nationwide approximately 10% are. At a minimum, we can reduce the government subsidy of this popular, but nonetheless expensive, program. Developed campgrounds are very expensive to develop and operate. They are also very popular.

How Do People Feel About Campground Fees?

Surprisingly, more than half of facility users will pay without hesitation. The Forest Service here in Alaska reports 77% compliance at more remote facilities and 92% compliance where a volunteer campground host is on the premises. My field staff tells me that many visitors, especially those from Outside, are amazed that no fees are charged in Alaska State Park campgrounds. Owners of private campgrounds are very much in favor of the charge. They are tired of the free competition. Last year, the Alaska Visitors' Association supported a previous attempt at legislation authorizing campsite fees.

How Much Would Be Charged and At Which Facilities?

Fees would be approximately \$6.00 per overnight use of a campsite for residents, and approximately \$8.00 for non-residents. At first, only those campgrounds with substantial improvements would be included, with a graduated fee being charged for facilities with running water and modern restrooms. A "season pass" should also be made available at between \$50.00 and \$75.00 per year. Many of the less-developed, more primitive campgrounds would remain free. But generally, the fancier the campground, the higher the fee.

How Would The Fees Be Collected?

The "iron ranger" self-registration fee station has been very successful for other agencies through the years. This is essentially a simple, slotted iron container located near the park entrance into which fees are deposited by visitors who will be overnighing at the campground. The fee station is self-operating and does not require staff. The station issues a camping permit which is placed on each vehicle dashboard. Park staff can then readily determine who has paid while on routine patrol. At larger facilities, a volunteer campground host will welcome each visitor, assisting with nearby facility locations and assuring general compliance with the campsite fee program.

How Much Revenue Would Be Generated and How Soon?

If legislation is passed in the 1985 session, the program could be started in May of 1986 at selected sites. Estimating a visitation rate for this year (1986) of nearly 7 million, initially \$400,000 to \$500,000 could be realized, increasing considerably each year. Indiana State Parks, for example, now collects 80% of their operating costs through fees and concession revenues.

Along with this proposed camping fee, I hope to work through existing regulations and statutes to generate revenue from programs such as public use cabins, guides and outfitters permits, concessions and tours of historical sites. I feel that with tourism being one of the largest job and revenue producing industries in Alaska, State Parks should be an active member of that

The Honorable Bettye Fahrenkamp
February 19, 1985
Page 3 -

industry. And with a declining revenue curve, it is encumbant on me to formulate economic strategies which make money and save money while serving the public.

General
A handwritten signature in black ink, appearing to read "Neil C. Johannsen". The signature is written in a cursive style with a long horizontal line extending to the right. The word "General" is printed in a small font above the beginning of the signature.

Neil C. Johannsen
Director

enclosure

cc: Esther C. Wunnicke, Commissioner, DNR

NCJ:clk



ALASKA VISITORS ASSOCIATION

P.O. BOX 10-2220
ANCHORAGE, AK 99510
(907) 276-6663

Telex:
Within Alaska 25-147
Lower U.S. 090 25-147
Canada 0305 25-147
International 314-25-147

1983-84 EXECUTIVE OFFICERS

President
ROBERT H. BRENNAN
Princess Tours
Seattle, Washington

**Vice President/
Administration**
RAL WEST-HARDWICK
Alaska West Associates
Anchorage, Alaska

**Vice President/
Government Relations**
CHRIS VON IMHOF
Alyeska Resort
Girdwood, Alaska

**Vice President/
Marketing**
DEAN WEIDNER
Travelaska Tours
Seattle, Washington

Secretary
DENNIS BRANDON
Sheffield Enterprises
Anchorage, Alaska

Treasurer
A. K. "KIRK" LANTERMAN
Westours, Inc.
Seattle, Washington

Executive Director
DALE FOX

PAST PRESIDENTS

GEORGE SUNDBORG
1950

ROBERT E. ELLIS
1951-1952

EDWARD J. COFFEY
1952-1955

MARSHALL CRUTCHER
1955-1956

BEN CRAWFORD
1956-1957

EVERETT PATTON
1957-1959

ROBERT A. BAKER
1959-1960

ROBERT E. ELLIS
1960-1962

ROBERT GIERSDORF
1962-1963

E.E. SWOFFORD
1963-1964

H. JACK MUSIEL
1964-1966

JAMES JOHNSON
1966-1967

FRANK DOWNEY
1967-1968

BILL SHEFFIELD
1968-1969

JOHN MONROE
1969-1970

RONALD LATHROP
1970-1971

JOHN STEVENS
1971-1972

LEN LAURANCE
1972-1973

E. AL PARRISH
1973-1974

A.E. "BUD" HAGBERG
1974-1975

CHUCK WEST
1975-1977

CHARLES CONWAY
1977-1978

JIM BINKLEY
1978-1979

MARTHA EDWARDS
1979-1980

ROLF KLUG
1980-1981

DAVE PALMER
1981-1982

CHRIS VON IMHOF
1982-1983

April 16, 1984

Honorable Robert Bettisworth
Alaska House of Representatives
State Capital
Pouch V
Juneau, Alaska

Dear Rep. Bettisworth:

I am pleased to inform you that the AVA Board of Directors last week voted to support passage of House Bill 486, relating to user fees for parks facilities. As sponsor of the measure, I'm sure you understand how private industry feels about unfair competition the state currently participates in around Alaska.

The state will benefit from this legislation and AVA lends it support to efforts to getting the bill passed.

Sincerely,

Dale Fox,
Executive Director

cc: Neil Johannsen

STATE OF ALASKA

BILL SHEFFIELD, GOVERNOR

DEPARTMENT OF NATURAL RESOURCES

POUCH M
JUNEAU, ALASKA 99811
PHONE: 907-465-2400

OFFICE OF THE COMMISSIONER

March 12, 1985

The Honorable Richard Shultz
Co-Chair, House Resources Committee
Pouch V
Juneau, AK 99811

Dear Representative Shultz:

As you have requested, the Department of Natural Resources has reviewed HB 267 which authorizes the collection of fees for use of developed state park campsites.

The department supports this bill because it will generate revenue for the state and help to offset state park operation and maintenance costs. In addition, when recreation user fees are charged, park managers have found that vandalism decreases. Decreases in vandalism would, in turn, save the state money and allow park employees more time for necessary maintenance and supervisory activities.

Please let me know if I may provide additional information about the proposed fee system.

Sincerely,

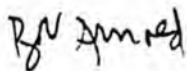

f Esther C. Wunnicke
Commissioner

STATE OF ALASKA 1985 LEGISLATIVE SESSION
FISCAL NOTE

Revision Date: _____

REQUEST

Bill/Resolution No.: HB 267
Title: State Park Camping fees

FISCAL DETAIL

Agency Affected: Natural Resources, Div. of Parks
Program Category Affected: NAMEC

Sponsor: House Resources
Requestor: House Resources Comm.
Date of Request: 3/11/85

BRU, Program or Subprogram(s) Affected: _____

EXPENDITURES/REVENUES: (Thousands of Dollars)

	FY 85	FY 86	FY 87	FY 88	FY 89	FY 90
OPERATING						
100 PERSONAL SERVICES						
200 TRAVEL		31.4	38.3	38.3	38.3	38.3
300 CONTRACTUAL						
400 SUPPLIES		9.0	6.0	6.0	6.0	6.0
500 EQUIPMENT		42.0	15.4	15.4	15.4	15.4
600 LAND & STRUCTURES		5.0	5.0	5.0	-0-	-0-
700 GRANTS, CLAIMS						
800 MISCELLANEOUS						
TOTAL OPERATING		87.4	64.7	64.7	59.7	59.7
CAPITAL						
REVENUE		108.6	420.0	440.0	480.0	520.0

FUNDING: (Thousands of Dollars)

GENERAL FUND		87.4	64.7	64.7	59.7	59.7
FEDERAL FUNDS						
OTHER						
TOTAL		87.4	64.7	64.7	59.7	59.7

POSITIONS:

FULL-TIME		-0-	-0-	-0-	-0-	-0-
PART-TIME		1	1	1	1	1
TEMPORARY		-0-	-0-	-0-	-0-	-0-

ANALYSIS: Attach a separate page if necessary

Prepared By: Neil Johannsen/Sharon Barton *Barton* Phone: 265-4504
Division: Parks and Outdoor Recreation/ Management Date: 3/5/85

Approved by Commissioner: Wm. D. Samuel Deputy Date: 3/12/85
Agency: Natural Resources

Distribution (by Agency preparing fiscal note):

- Legislative Finance
- Legislative Sponsor
- Requestor
- Office of Management and Budget
- Impacted Agency(ies)

7/1/84

STATE OF ALASKA 1985 LEGISLATIVE SESSION
FISCAL NOTE

Revision Date: _____

REQUEST

Bill/Resolution No.: HB 267
Title: State Park Camping fees

FISCAL DETAIL

Agency Affected: Natural Resources, Div. of Parks
Program Category Affected: NRMEC

Sponsor: House Resources
Requestor: House Resources Comm.
Date of Request: 3/11/85

BRU, Program or Subprogram(s) Affected: _____

EXPENDITURES/REVENUES: (Thousands of Dollars)

	FY 85	FY 86	FY 87	FY 88	FY 89	FY 90
OPERATING						
100 PERSONAL SERVICES		31.4	38.3	38.3	38.3	38.3
200 TRAVEL						
300 CONTRACTUAL		9.0	6.0	6.0	6.0	6.0
400 SUPPLIES		42.0	15.4	15.4	15.4	15.4
500 EQUIPMENT		5.0	5.0	5.0	-0-	-0-
600 LAND & STRUCTURES						
700 GRANTS, CLAIMS						
800 MISCELLANEOUS						
TOTAL OPERATING		87.4	64.7	64.7	59.7	59.7

CAPITAL						
----------------	--	--	--	--	--	--

REVENUE		108.6	420.0	440.0	480.0	520.0
----------------	--	-------	-------	-------	-------	-------

FUNDING: (Thousands of Dollars)

GENERAL FUND		87.4	64.7	64.7	59.7	59.7
FEDERAL FUNDS						
OTHER						
TOTAL		87.4	64.7	64.7	59.7	59.7

POSITIONS:

FULL-TIME		-0-	-0-	-0-	-0-	-0-
PART-TIME		1	1	1	1	1
TEMPORARY		-0-	-0-	-0-	-0-	-0-

ANALYSIS: Attach a separate page if necessary

Prepared By: Neil Johannsen/Sharon Barton *Barton* Phone: 265-4504
Division: Parks and Outdoor Recreation/ Management Date: 3/5/85

Approved by Commissioner: William D. Schmidt, Deputy Date: 3/12/85
Agency: Natural Resources

Distribution (by Agency preparing fiscal note):
Legislative Finance
Legislative Sponsor
Requestor
Office of Management and Budget
Impacted Agency(ies)

7/1/84

Attachment to Bill Analysis
State Park Campground Fees

The bill would authorize camping fees for developed campgrounds in the state park system. Fees would be charged on a daily, per vehicle basis in those campgrounds that offer the highest level of facilities and that are economical in terms of administering the program. The cost of implementing the proposed fee system is \$87.4 in FY 86. These funds would provide for the installation of "iron rangers" at self-service fee payment stations at the entrances of state-operated campgrounds. The "iron ranger" is a heavily built iron deposit box that is designed to receive envelopes, providing a very high degree of security. The fiscal note would provide a part-time Accounting Technician for the Division of Management; the Division of Parks and Outdoor Recreation will add time to existing positions for employee overtime to perform the revenue collection tasks, compliance checks, communication with campground hosts, and field accounting functions.

The Division of Parks and Outdoor Recreation would implement the fee collection system through the use of the "Iron ranger" and the use of volunteer camp hosts to insure compliance. The U. S. Forest Service, National Park Service, British Columbia Provincial Park Service and numerous state park systems have found self-collection "iron rangers" vandal proof and to have a very high (80%) public compliance. The contractual service funds would be used to build instructional signs at fee stations and to fund additional vehicle mileage involved with collection, cash deposits, and compliance checks. Supplies funding is needed to purchase the building materials for the self-service collection stations, printing of collection envelopes and field accounting forms. Equipment funds will be used to purchase the safes for remote ranger stations.

The fiscal note reflects the high first year start-up costs of a camping fee program, but assuming that the Division of Parks and Outdoor Recreation does not have a fee system functioning until July 15 and in only nine campgrounds, the expected revenue is \$108.6. This revenue will increase substantially over the five-year period forecasted. The investment-return ration becomes substantial following initial start-up costs. Within 4 years, an investment of about \$60,000 will return revenues of near half a million.

Projected revenue from
State Park Campground Fee
Summer 1986

South Central Region	RTS	% mean occup.	Capacity	Open days	Compl. Rate	Total
<u>A. Mat-Su</u>						
1. Byers Lake SRS	6	40	60	90	80	19.4
2. Nancy Lk. SRS	6	60	30	120	80	10.4
3. South RollyCG	6	30	100	110	80	15.8
4. Finger Lk. SRS	6	50	40	120	85	12.2
5. King MNT SRS	6	50	20	110	75	5.0
6. Moose R. SRS	6	50	10	110	75	2.5
7. Matanuska. GL	6	50	13	110	75	3.2
8. Rocky Lk. SRS	3	50	10	110	75	1.2
<u>B. Copper Basin</u>						
1. Dry CRK. SRS	6	60	60	120	80	20.7
2. Lk. Louise SRS	6	40	20	90	60	2.6
3. Blueberry SRS	6	40	10	90	60	1.3
4. Little Tonsina	6	60	10	110	70	2.8
5. Porcupine Crk	6	60	10	110	70	2.8
<u>C. Chugach</u>						
1. Eklutna CG.	6	50	50	150	75	16.9
2. Eagle R. CG.	8	80	36	150	85	29.4
3. Bird Creek CG	6	80	25	150	85	15.3
<u>Kenai Area</u>						
1. Izaak Walt. srs	6	75	25	120	85	6.9
2. Discovery CG.	6	40	67	120	70	11.5
3. Johnson Lk. srs	6	40	40	120	80	9.2
4. Ninilchik SRA	6	60	50	120	80	17.3
5. Anchor R. SRA	3	60	38	120	80	6.7
6. Kasilof R. SRS	6	50	16	120	80	4.6
<u>Kodiak Ranger District</u>						
1. Ambercr. SHP	6	80	14	120	85	6.9
2. Bushkin R. Srs	6	80	18	120	70	7.3
<u>SE Region</u>						
1. Settlers Cove	6	60	12	120	70	3.6
2. Chilcoat Lk.	6	80	32	150	85	19.6
3. Chilkat SP.	6	50	32	150	80	11.5
<u>Northern Region</u>						
1. Quartz Lk. srs	6	60	16	110	75	4.8
2. Harding Lk. srs	6	40	90	110	90	21.4
3. Chena R. SRA	6	35	56	110	60	7.8
4. Chena SRS	8	85	60	120	90	44.0
5. Eagle Tr. SRS	6	50	40	110	70	9.2

NORTHERN (CON'T)	RTS	% MEAN OCCUP.	CAPACITY	OPEN DAYS	COMPL RATE	TOTAL
6. Tok River SRS	6	50	40	110	70	9.2
7. Clearwater SRS	6	50	20	90	70	<u>3.8</u>
SUBTOTAL RESIDENT						357.8
NON-RESIDENT SURCHARGE						62.2
GRAND TOTAL						<u>\$420.0</u>



Province of
British Columbia
Ministry of
Lands, Parks
and Housing

FORUM

SELF REGISTRATION IN PARKS A SUCCESS

Will B.C. campers voluntarily register and pay for campground use when there isn't an official there to ask for their money? The answer is an overwhelming "yes", as the Parks and Outdoor Recreation Division showed this year in 52 provincial parks.

Two years ago, the division launched a pilot program of self-registration fee collections in seven parks, then increased it to 11 parks in 1979 and 52 this year. The objective was to monitor both the response of campers and the effectiveness from an operations standpoint. It has proven to be an entirely valid system for both users and operators.

B.C. was the first Canadian province to use the self-registration system, but credit for its organization goes to the U.S. Forest Service, which pioneered it in the early 1970's.

The principle behind self-registration is simple: the responsibility for registering and paying camping fees falls to the camper rather than park staff. The advantage to campers is obvious: convenience. They can now pay their fee when they arrive instead of waiting for a collector to come around at a specified time. They can also pay in advance for as many nights as they wish. Assuming they do (and statistics now show this to be an entirely valid assumption), fee collectors are now free to work in other areas of park operations to improve service to the public.

The implementation of the system is also fairly simple: as campers enter the campground, a sign advises them that attendants do not collect fees. Campers are asked to select a site, then go to the self-registration station and pay. At these fee stations, strategically located in the campground, envelopes are provided, the camper fills in the registration information, puts the fee in the envelope, seals it, and deposits it in a vault, first tearing off the receipt stub. During the evening, park staff check each vault to ensure payment has been received.

During the two year period, the average voluntary compliance rate was over 80% and, when additional information, instruc-

tions, or reminders were given, the average was a stunning 96%! This rate is as high as that achieved with traditional methods of fee collection. Based on B.C.'s experimental program, Yoho National Park started a similar system in the summer of 1979. Their volunteer compliance averaged 92% — another indication of the system's viability and people's basic honesty!

To get public reaction to the new system, the division monitored some of the 20,000 camping parties who participated in the 1978 pilot program. At that time, users did not show any strong objections to the system. They were undecided as to whether or not there was a decrease in contact with staff and it was generally felt there were no problems with change, foreign currency (American) or the instructions. They did, however, remark on the appearance of the fee station, because it did not blend with park environment. This response was welcomed because the fee stations and vaults were designed to be easily identified.

As with most new concepts, improvements are an integral part of their success. The self-registration system was no exception. Several recommendations were made by field staff and improvements and modifications were made.



Ron Kerr of the Parks and Outdoor Recreation Division Operations Branch demonstrates the self-registration fee system. Ron is filling out the permit envelope following the instructions on the sign. In the foreground is the vault where Ron will deposit the permit envelope and camping fee.

NOTE: FILL INSIDE OF
TUBE W/CONC. TILL
EVEN WITH TOP
LOWER LIP, W/1"
SLOPE TO EITHER
SIDE

36 x 36 x 3"
SOUTH PAD
2.50 CU. FT.

3.1 CU. FT.
CONCRETE

.458 CU. FT.
CONCRETE

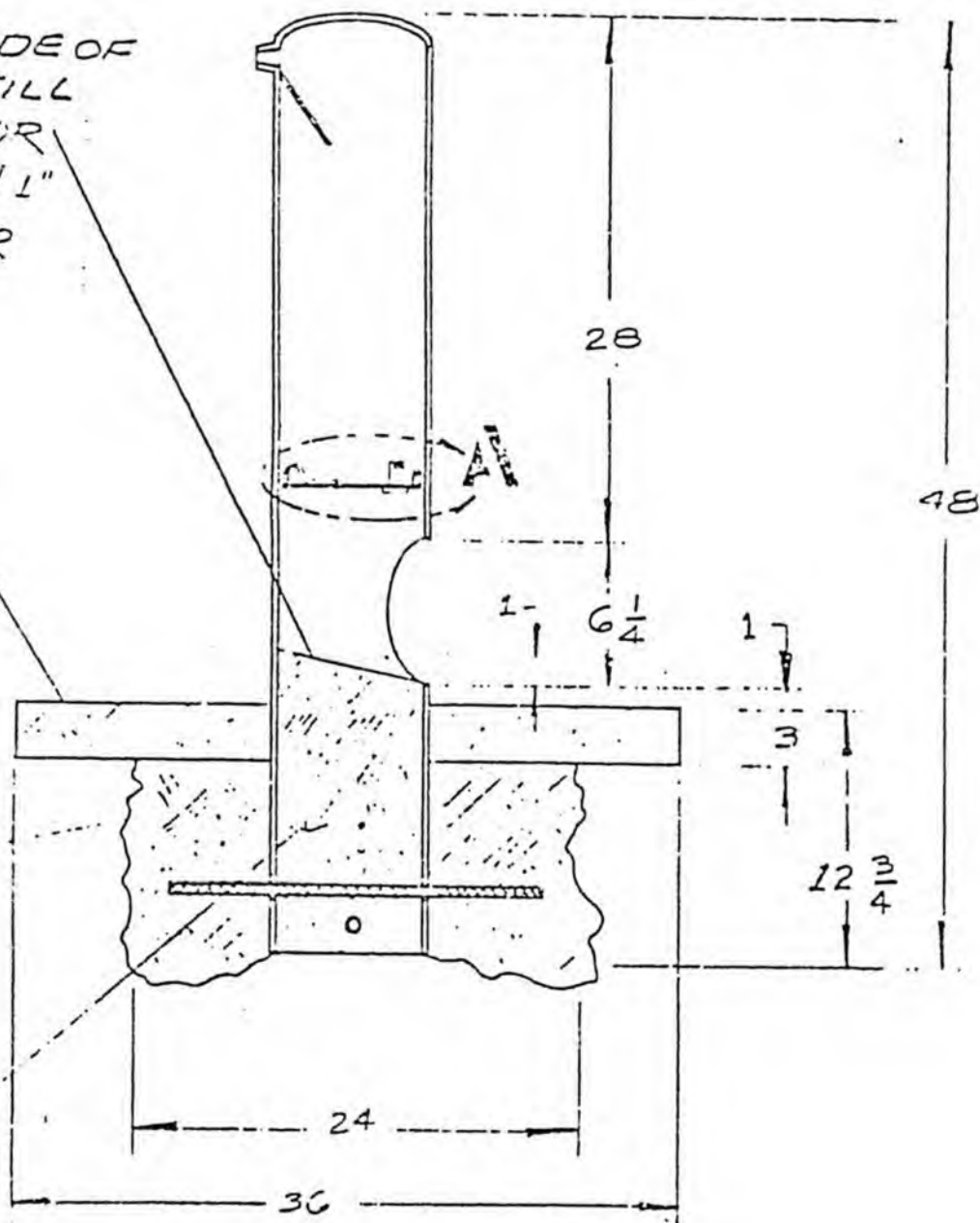

Side view of a typical
fee collection device
or "iron ranger".

ENVELOPE DEPOSITORY

- D-625 DEPOSITORY BOX 48" HIGH
- DOMED HEAD AND REINFORCED SLOT PREVENTS DISTORTION BY PRYING
- STURDY 5" IRON PIPE PREVENTS USE OF PIPE CUTTER
- HIDDEN LOCK PANEL INACCESSIBLE FOR CHISELING, DRILLING OR PRYING
- ANTI TILT RING ABOVE LOCK PLATE
- CEMENT CAST INTO PIPE ANCHORS IT PERMANENTLY TO BASE
- FOREST GREEN PAINT

72.50 EACH

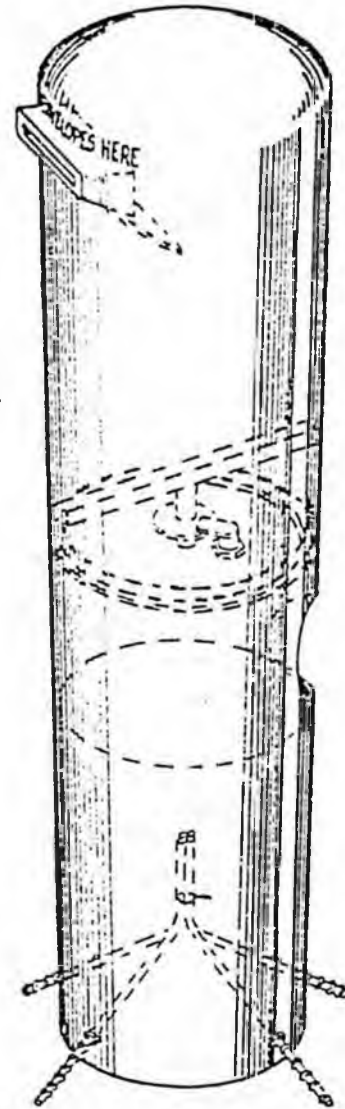

ALL PRICES F.O.B. ORLAND
Subject To Change Without Notice

NOTE: ALL shipments will be prepaid via most economical method
Shipping charges will appear as a separate item on your invoice.



P.O. BOX 876 • ORLAND, CA. 95963 • (916) 865-4777

NOTE: FILL INSIDE OF
TUBE W/ CONC. TILL
EVEN WITH DOOR
LOWER LIP, W/ 1"
SLOPE TO EITHER
SIDE

20 x 20 x 3"
SOUTH SIDE
2.125 DIA

31 CU. FT.
CONCRETE

.458 CU. FT.
CONCRETE

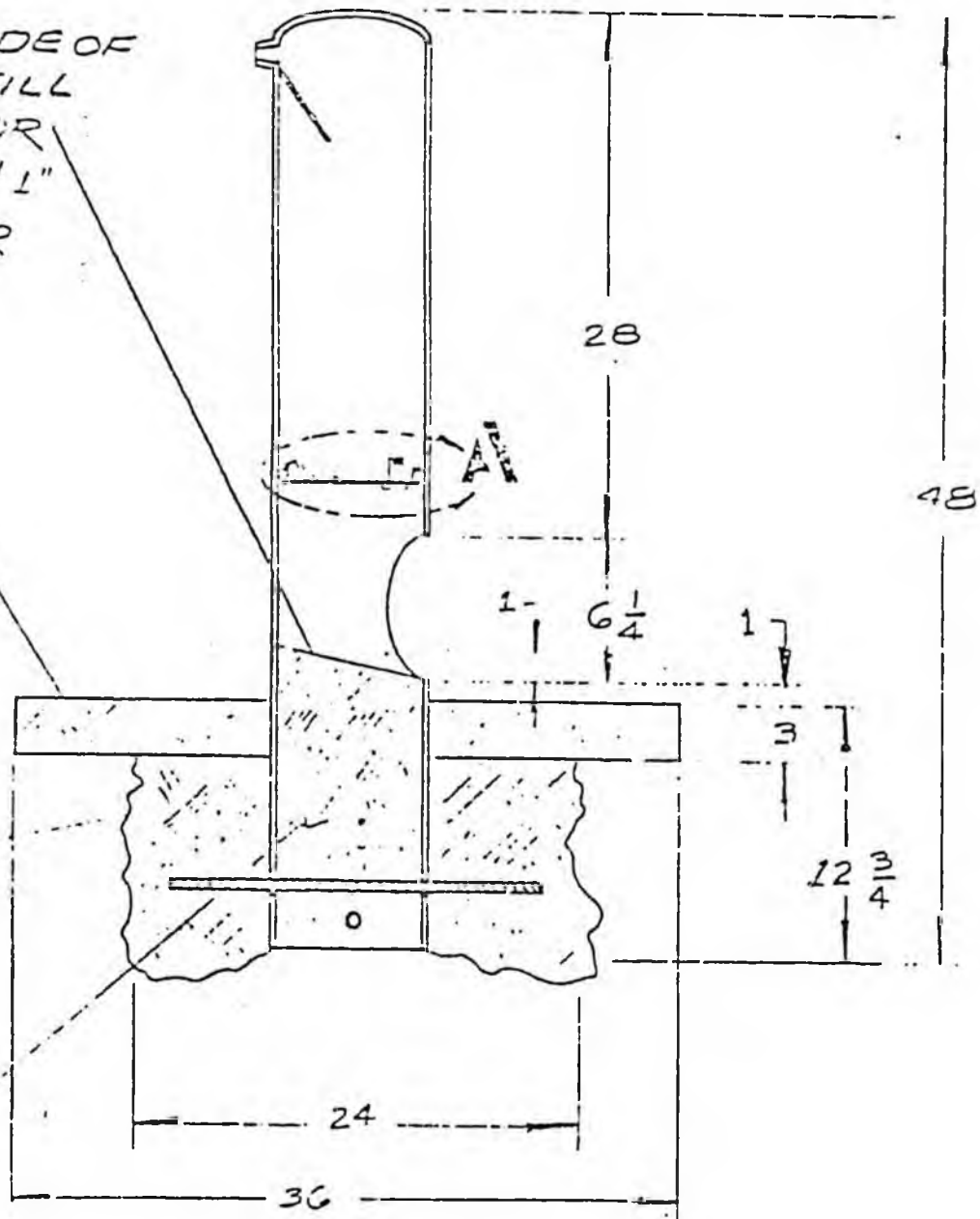

Side view of a typical
fee collection device
or "iron ranger".

PERMIT

Valid Only at This Site for
the Day(s) Paid Beginning
Purchase Date ___/___/___
Camping: Check Out 2 p.m.
Number of Days Paid ___



No. B 0531009

Detach this stub and display on
vehicle dashboard clearly visible
from outside.

No. B 0531009

U.S. Department of Agriculture
Forest Service

COMPLETE THIS BLOCK ONLY ONCE DURING YOUR STAY		
ARRIVAL _____	(HOUR)	(AM or PM)
No. PEOPLE IN VEHICLE _____	HOME ZIP CODE _____	
EXPECTED DEPARTURE _____	(DATE)	(HOUR) (AM or PM)

TO VALIDATE COMPLETE THE FOLLOWING

Amount Enclosed \$ _____ Number of Days Paid _____
Purchase Date ___/___/___
Car License _____ State _____
Golden Age Passport No. (if applicable) _____

CAMPGROUND USERS MUST COMPLETE THE FOLLOWING:

Camp Unit No. _____

2300-26b (2/76)

PERMIT

Valid Only at This Site for
the Day(s) Paid Beginning
Purchase Date ___/___/___
Camping: Check Out 2 p.m.
Number of Days Paid ___



No. B 0531010

Detach this stub and display on
vehicle dashboard clearly visible
from outside.

No. B 0531010

U.S. Department of Agriculture
Forest Service

COMPLETE THIS BLOCK ONLY ONCE DURING YOUR STAY		
ARRIVAL _____	(HOUR)	(AM or PM)
No. PEOPLE IN VEHICLE _____	HOME ZIP CODE _____	
EXPECTED DEPARTURE _____	(DATE)	(HOUR) (AM or PM)

TO VALIDATE COMPLETE THE FOLLOWING

Amount Enclosed \$ _____ Number of Days Paid _____
Purchase Date ___/___/___
Car License _____ State _____
Golden Age Passport No. (if applicable) _____

CAMPGROUND USERS MUST COMPLETE THE FOLLOWING:

Camp Unit No. _____

2300-26b (2/76)



ALASKA

APR 26 1985

UNIQUE



P.O. BOX 2507 FAIRBANKS, AK 99707

April 22, 1985

Senator Don Bennett
Pouch V
Juneau, AK 99811

Re: Parks Fee Bill CS-267

Dear Senator Bennett:

I appreciated the opportunity to visit with you while you were in Fairbanks last week.

As you know, I have been working with the Division of Parks for over two years trying to get a lease or concession on the Chena Wayside Campground. The main problem is the law, which does not allow a charge for use of a State owned park.

It seems with last year's bills, as with this year's bill, that there are some reservations about allowing the State to charge.

With the increased population and a growing tourist industry, the time has come for the State to take a look at the possibility of private operators for parks when feasible. At least the State should have the option of private concessions.

My proposal would give the State the right to consider private concessions but would not in any way force it to do so. I would propose that you amend Sec. 28.10.411(e) to read as follows:

Notwithstanding any other provision of law, the fees paid for registering a vehicle under A.S. 28.10.421(b)(1), (2), (5), (6) or (d) shall include all fees required for entry into and use of a state park or campground, except where park or campground is leased or concessioned to a private operator.

DRAFT
Alaska State Park System User Fee Policy

The policy of the Division of Parks and Outdoor Recreation regarding user fees in state park units is:

1. To establish and levy affordable entry, facility use and program fees where it is practical to do so and where the facilities or programs are worthy of the fees charged. Initial fees shall be levied only for high quality and urban adjacent campsites and for tours of the Wickersham State Historic Site.
2. Fees should be charged for highly specialized developments or programs catering to a specific clientele. Fee schedules shall seek to significantly reduce, or if possible eliminate, user subsidies.
3. Some fees may be adjusted annually, effective January 1. The overall percentage fee increase shall not be greater than the rate of inflation for the preceding year and/or a reasonable amount of increase if it is found that a user fee has been artificially low.
4. Fees schedules shall generally be in round dollar numbers to avoid the expense and inconvenience of making change.
5. Fees may be waived for school groups on a reservation basis, when their visit or trip is in conjunction with an educational program for grades K through 12.
6. Where fees are charged on an individual rather than a per vehicle basis, fees may be reduced for visitors under 12 or over 65 years of age.
7. Insofar as possible every effort should be made to insure that user fees do not unreasonably discriminate against economically disadvantaged or other minority groups.
8. Annual use permits may be established and used in lieu of paying daily fees to provide a moderate savings to frequent users of park facilities.