

Introduced: 4/14/81
Referred: Finance

BY COLLETTA, KERTTULA,
KELLY AND FAHRENKAMP

1 IN THE SENATE

2 SPONSOR SUBSTITUTE FOR SENATE CONCURRENT RESOLUTION NO. 17

3 IN THE LEGISLATURE OF THE STATE OF ALASKA

4 TWELFTH LEGISLATURE - FIRST SESSION

5 Relating to the development of a
6 wood products industry in the state.

7 BE IT RESOLVED BY THE LEGISLATURE OF THE STATE OF ALASKA:

8 WHEREAS future expansion of agriculture, road building, and hydro-
9 electric power will require the clearing of timber from thousands of acres
10 of land in interior Alaska; and

11 WHEREAS timber cleared from this land has economic potential, for
12 example, as a supplement to coal as a fuel in coal-fired electric boilers,
13 as wood chips for export for the production of wood pulp, as wood fiber for
14 the production of fiberboard and particleboard, and for the production of
15 lumber, fireplace logs, alcohol, methane, pelletized fuel, and animal feed
16 supplements; and

17 WHEREAS land clearing may provide opportunities for the use of valuable
18 timber resources to assist existing or new economic activities;

19 BE IT RESOLVED by the Alaska State Legislature that it is the policy of
20 the state to engage in public land clearing with a coordinated effort by
21 state agencies and private individuals involved to achieve the highest and
22 best use of the wood cleared from each project, and that revenue produced
23 from costs saved by the use of wood cleared from the land be credited against
24 the cost of the project for which the land is cleared; and be it

25 FURTHER RESOLVED that it is the policy of the state that state agencies
26 involved in timber utilization, including state agencies making loans and
27 grants for timber utilization activities and alternative energy development,
28 should cooperate to develop coordinated policies and objectives relating to
29 timber, wood pulp, and wood fiber utilization from land clearing; and be it

1 LEGISLATURE RESOLVED that the governor is respectfully requested to direct
2 the commissioner of natural resources to include in his report submitted to
3 the legislature under AS 41.17.070(b) the outcome of discussions and measures
4 taken to coordinate policies and objectives relating to timber and wood
5 fiber utilization from land clearing.

6
7
8
9
10
11
12
13
14
15
16
17
18
19
20
21
22
23
24
25
26
27
28
29

Introduced: 3/16/81
Referred: Resources and
Finance

BY COLLETTA, KERTTULA,
KELLY AND FAHRENKAMP

1 IN THE SENATE

2 SENATE CONCURRENT RESOLUTION NO. 17

3 IN THE LEGISLATURE OF THE STATE OF ALASKA

4 TWELFTH LEGISLATURE - FIRST SESSION

5 Relating to the development of a
6 wood products industry in the state.

7 BE IT RESOLVED BY THE LEGISLATURE OF THE STATE OF ALASKA:

8 WHEREAS future expansion of agriculture, road building, and hydro-
9 electric power will require the clearing of timber from thousands of acres
10 of land in interior Alaska; and

11 WHEREAS timber cleared from this land has economic potential as a
12 supplement to coal as a fuel in coal-fired electric boilers, as wood chips
13 for export for the production of wood pulp, as wood fiber for the production
14 of fiberboard and particleboard, and for the production of lumber, fireplace
15 logs, methane, pelletized fuel, and animal feed supplements; and

16 WHEREAS land clearing may provide an opportunity for the establishment
17 of a wood fiber industry without the initial expenses of required reforesta-
18 tion and land regeneration;

19 BE IT RESOLVED by the Alaska State Legislature that it is the policy of
20 the state to engage in public land clearing with a coordinated effort by
21 state agencies and private individuals involved to achieve the highest and
22 best use of the wood cleared from each project, and that revenue produced
23 from costs saved by the use of wood cleared from the land be credited against
24 the cost of the project for which the land is cleared; and be it

25 FURTHER RESOLVED that it is the policy of the state that state agencies
26 making expenditures, including loans and grants, for the development of
27 alternative energy and wood fiber utilization from timber clearing should
28 cooperate to develop coordinated policies and objectives relating to timber
29 and wood fiber utilization from land clearing; and be it

1 FURTHER RESOLVED that the governor is respectfully requested to direct
2 the commissioner of natural resources to include in his report submitted to
3 the legislature under AS 41.17.070(b) the outcome of discussions and measures
4 taken to coordinate policies and objectives relating to timber and wood
5 fiber utilization from land clearing.

6
7
8
9
10
11
12
13
14
15
16
17
18
19
20
21
22
23
24
25
26
27
28
29

To: Puller
4/13/51

BY COLLETTA, KERTTULA,
KELLY AND FAHRENKAMP

1 IN THE SENATE

2 SPONSOR SUBSTITUTE FOR SENATE CONCURRENT RESOLUTION NO. 17

3 IN THE LEGISLATURE OF THE STATE OF ALASKA

4 TWELFTH LEGISLATURE - FIRST SESSION

5 Relating to the development of a
6 wood products industry in the state.

7 BE IT RESOLVED BY THE LEGISLATURE OF THE STATE OF ALASKA:

8 WHEREAS future expansion of agriculture, road building, and hydro-
9 electric power will require the clearing of timber from thousands of acres
10 of land in interior Alaska; and

11 WHEREAS timber cleared from this land has economic potential, for
12 example, as a supplement to coal as a fuel in coal-fired electric boilers,
13 as wood chips for export for the production of wood pulp, as wood fiber for
14 the production of fiberboard and particleboard, and for the production of
15 lumber, fireplace logs, alcohol, methane, pelletized fuel, and animal feed
16 supplements; and

17 WHEREAS land clearing may provide opportunities for the use of valuable
18 timber resources to assist existing or new economic activities;

19 BE IT RESOLVED by the Alaska State Legislature that it is the policy of
20 the state to engage in public land clearing with a coordinated effort by
21 state agencies and private individuals involved to achieve the highest and
22 best use of the wood cleared from each project, and that revenue produced
23 from costs saved by the use of wood cleared from the land be credited against
24 the cost of the project for which the land is cleared; and be it

25 FURTHER RESOLVED that it is the policy of the state that state agencies
26 involved in timber utilization, including state agencies making loans and
27 grants for timber utilization activities and alternative energy development,
28 should cooperate to develop coordinated policies and objectives relating to
29 timber, wood pulp, and wood fiber utilization from land clearing; and be it

*Delivered to
legis Affairs
9:45 am
4/13/81*

BY COLLETTA, KERTTULA,
KELLY AND FAHRENKAMP

1 IN THE SENATE

2 SPONSOR SUBSTITUTE FOR SENATE CONCURRENT RESOLUTION NO. 17

3 IN THE LEGISLATURE OF THE STATE OF ALASKA

4 TWELFTH LEGISLATURE - FIRST SESSION

5 Relating to the development of a
6 wood products industry in the state.

7 BE IT RESOLVED BY THE LEGISLATURE OF THE STATE OF ALASKA:

8 WHEREAS future expansion of agriculture, road building, and hydro-
9 electric power will require the clearing of timber from thousands of acres
10 of land in interior Alaska; and

11 WHEREAS timber cleared from this land has economic potential, for
12 example, as a supplement to coal as a fuel in coal-fired electric boilers,
13 as wood chips for export for the production of wood pulp, as wood fiber for
14 the production of fiberboard and particleboard, and for the production of
15 lumber, fireplace logs, alcohol, methane, pelletized fuel, and animal feed
16 supplements; and

17 WHEREAS land clearing may provide opportunities for the use of valuable
18 timber resources to assist existing or new economic activities;

19 BE IT RESOLVED by the Alaska State Legislature that it is the policy of
20 the state to engage in public land clearing with a coordinated effort by
21 state agencies and private individuals involved to achieve the highest and
22 best use of the wood cleared from each project, and that revenue produced
23 from costs saved by the use of wood cleared from the land be credited against
24 the cost of the project for which the land is cleared; and be it

25 FURTHER RESOLVED that it is the policy of the state that state agencies
26 involved in timber utilization, including state agencies making loans and
27 grants for timber utilization activities and alternative energy development,
28 should cooperate to develop coordinated policies and objectives relating to
29 timber, wood pulp, and wood fiber utilization from land clearing; and be it

1 FURTHER RESOLVED that the governor is respectfully requested to direct
2 the commissioner of natural resources to include in his report submitted to
3 the legislature under AS 41.17.070(b) the outcome of discussions and measures
4 taken to coordinate policies and objectives relating to timber and wood
5 fiber utilization from land clearing.

6
7
8
9
10
11
12
13
14
15
16
17
18
19
20
21
22
23
24
25
26
27
28
29

JAY S. HAMMOND
GOVERNOR



STATE OF ALASKA
OFFICE OF THE GOVERNOR
JUNEAU

April 1, 1981

The Honorable Terry Gardiner
Alaska State Legislature
House Resources Committee
Pouch V
Juneau, Alaska 99811

Dear Representative Gardiner:

I have your letter of March 6, 1981, concerning timber utilization at Point MacKenzie.

Enclosed you will find a copy of the settlement of the litigation agreed to by the State and the Sierra Club concerning that issue.

Also enclosed please find an estimate from the Department of Natural Resources of the amount of commercial spruce on each tract and the dollar value calculated at \$35/MBF (thousand board foot). Ted Smith states that \$20/MBF is a more reasonable figure for a total value of about \$50,000. If there is as much as 9 million board feet (9,000 MBF) the value would still be only \$180,000. The value of the birch firewood has been estimated at \$90,000.

Certainly, these figures are far less than the "millions" quoted by the media.

I am also enclosing statements from various individuals with knowledge and personal experience in the Point MacKenzie area. I believe you will find their statements of much value. I would especially commend to you the words of Glen Franklin, the Contracts Administrator for the Special Projects Office in Delta Junction. He has much experience in timber utilization in Canada's Peace River area and supervised the test clearing work at Point MacKenzie.

Thank you for your interest in this matter. We, too, are certainly desirous of the best feasible use of those timber resources.

Sincerely,

Jay S. Hammond
Governor

Enclosures

✓ cc: The Honorable Bettye Fahrenkamp
Chairman
Senate Resources Committee
w/Enclosures

1075843

JG

Alaska State Legislature

House of Representatives

RECEIVED

MAR 10 '81

Committee on Resources

GOVERNORS OFFICE

State Capitol

Juneau, Alaska 99811

Terry Gardiner, Co-Chairman
Fred F. Zharoff, Co-Chairman
465-3715

March 6, 1981

The Honorable Jay Hammond
State of Alaska
Juneau, Alaska 99811

Dear Governor Hammond:

We, as many Alaskans, are concerned about the utilization of timber resources on agricultural lands. Since the time schedule precludes any legislative action at this time, we are sending you our concerns in letter form.

It would seem wisest for Alaska to guarantee that we fully utilize timber resources on agricultural land developments. The Pt. McKenzie area, according to your Department figures, contains 9 million board feet of commercial timber and 40 million board feet of firewood. This timber has the value of \$1-2 million, depending on your choice of estimates. While we desire agriculture development, we should not proceed such that wasteful uses are forced or utilized.

We would request that you insure that all timber in the Pt. McKenzie area is actually utilized rather than burned or put to any other such wasteful purpose. This will satisfy many concerns.

Terry Gardiner *Joseph Chuckwuk*
Fred F. Zharoff *Vernon Hurlbert*
Ben Grussendorf *Eric G. Sutcliffe*
Anthony Vaska *Sally Smith*
Ramona Barnes

RECEIVED MAR 23 1981

JG

Terry Gardiner	Joseph Chuckwuk
Fred F. Zharoff	Vernon Hurlbert
Ben Grussendorf	Eric Sutcliffe
Anthony Vaska	Sally Smith
Ramona Barnes	

MEMORANDUM

To: Barbara Miracle
Assistant Attorney General
Department of Law

Date: March 10, 1981

From: Glen Franklin
Contracts Administrator
Special Projects Office
Office of the Governor

Re: Surplus Wood Disposal
on Point MacKenzie
Agricultural Project:
Your Request for Comments
3/6/81

As the person responsible for the administration of clearing contracts on the Delta project and for our test clearing effort on Point MacKenzie, I can write from substantial experience on the question of wood and timber values within these projects.

The claims by Mr. Lowe of the Sierra Club and some members of the Alaska Association of Independent Loggers concerning timber values on the Point MacKenzie Project are spurious. One may guess, without having been privy to their respective calculations, that the ADL Forestry stem-counts for one or two of the most heavily timbered tracts were used, then generalized for the entire project acreage. Our test clearing effort, which covered three large tracts, plus a small parcel of university land, showed fewer than 50 white spruce (*Picea glauca*) stems of harvestable size and totaling less than 2,000 board feet. To be sure, these particular tracts were chosen for our test on that criterion (i.e., no timber).

Colleagues and I have cruised every tract within this project and have concluded that no more than eight of these 31 tracts show even marginal quantities of white spruce. As for firewood, one should dismiss without discussion the argument chained-down deciduous stems are rendered unusable. We heard this assertion prior to start-up in Delta and heard nothing more of it after woodcutters had experienced salvage after chaining. An excellent demonstration is also available on Point MacKenzie, Tract 11, where we left one mile-long strip by 300 feet chained down for salvage in December. By January 20, when I again looked at this test strip, virtually all birch and perhaps 50 percent of the aspen/poplar had been removed by woodcutters. This is the program and schedule which I would recommend:

Chain down of each tract this spring, then idle equipment through summer and fall, while log and wood salvagers are encouraged to work the entire project, now made accessible by the windbreak and chaining trails. Stacking of remaining debris would follow the succeeding winter.

Four tracts of our Delta I project were judged by ADL Forestry to contain marketable timber and assessed stumpage. Of these four, one owner was successful in selling the stumpage to a (an) (amateur) salvager, but for considerably less than his own assessment

Memorandum to
Barbara Miracle

-2-

March 11, 1981

by the State. The salvager worked for one season with free labor and a sawmill, but has "folded" before removing all the purchased stems. The other three tract owners who purchased "commercial timber" have all tried to sell stumpage without success. One has purchased and used a sawmill. Each now concludes that he cannot compete with current prices for commercial timber. Not one of these four would now, after the fact, agree to pay anything for the "commercial timber" on his property.

Again concerning chaining, please understand that root systems must be removed from soil intended for agricultural use. Salvagers who cut standing material leave a stump which cannot be lifted by the chain. Chaining, on the other hand, leaves a tree stem which IS available for salvage. Thus, if the landowner is permitted to chain his material down, it is both available for salvage and ready for subsequent consolidation.

In summary, I urge that we leave the wood disposal to the discretion of each tract owner and charge him/her no stumpage for any alleged "commercial timber". I also recommend that he/she be required jto make the chained-down material available to the public.

REC'D FROM D.N.R.

Pt. MacKenzie Ag. Sale

White Spruce Data

<u>Tract No.</u>	<u>Parcel No.</u>	<u>White Spruce MBF (9" DBH)</u>	<u>Estimated Value *</u>
1	1	80	\$ 2,800.00
2	20	Ø	Ø
3	21	40	1,400.00
4	2	10	350.00
5	3	30	1,050.00
6	22	168	5,880.00
7	23	100	3,500.00
8	4	200	7,000.00
9	5	400	14,000.00
10	6	125	4,375.00
11	24	40 (½ chained)	1,400.00
12	7	110	3,850.00
13	8	109	3,815.00
14	9	370	12,950.00
15	10	80	2,800.00
16	11	75	2,625.00
17	12	80	2,800.00
18	25	125	4,375.00
19	26	175	6,125.00
20	Not For Sale		
21	27	80	2,800.00
22a	28	30	1,050.00
22b	29	50	1,750.00
23a&b	13	70	2,450.00
24	14	Ø	Ø
25	30	Ø (chained)	Ø
26	31	120	4,200.00
27	15	Ø (½ chained)	Ø
28	16	Ø	Ø
29	17	21	735.00
		<u>2,688 MBF</u>	<u>\$94,360.00</u>

*Estimated value @ \$35.00/MBF (Sale data from Trail Ridge Sales)

TED SMITH STATES THAT ³20/MBF IS A MUCH
MORE REALISTIC FIGURE. W.I.P.

UNITED STATES DEPARTMENT OF AGRICULTURE - SOIL CONSERVATION SERVICE

March 23, 1981

Honorable Terry Gardiner, Chairman
House Resources Committee
Mail Station 3100
Pouch V
Juneau, Alaska 99811

Dear Representative Gardiner:

One very important stage in an economical clearing process is the knockdown of the trees. This can be accomplished in several ways. The old standard was to simply push over the trees with a bulldozer. This method tends to skin up the trees and break and crush them severely. It is also a very expensive first step, due to the fact that the cat has to essentially walk over every inch of the land before it can start to push up the trees into piles.

In recent years chaining has been used very efficiently for knock-down. This process is much faster, since the cats can be spaced out, not needing to walk over the entire land area. Additionally, the chaining process is much less destructive to the trees being knocked down. Most trees are not rooted very well and are easily tipped over by the chaining without having to apply the heavier weight of the cat. Thus fewer trees are damaged. Chaining also tends to leave the trees in a much "neater" and more easily accessible condition. Cat knock-down tends to leave the trees in a very tangled mess.

It has been stated that chaining damages the trees so that they are not fit for logs or firewood. That is definitely not true. I have personally seen many hundreds of logs salvaged from chained woodland on the Delta Ag Project and numerous other clearing done in the Delta area. I also have cut in excess of 50 cords of firewood during the past several years. Perhaps as much as 50 percent has come from chained woodland.

Additional facts should also be considered. If the wood on a parcel of land is to be harvested, access is needed. Most amateur timber cutters do not have the equipment nor time to create access. But after a chaining operation is completed, the access is then available, thus saving the amateur considerable time and effort.

In summary, chaining is an efficient and economical process used to help develop agricultural land, plus it is not severely destructive to the wood resource, which we all want to be utilized.

Sincerely,

Roger Doyer
District Conservationist
Fairbanks

COOPERATIVE EXTENSION SERVICE - UNIVERSITY OF ALASKA, FAIRBANKS
=====

Tanana District
P. O. Box 349
Delta Junction, Alaska 99737
Phone: (907) 895-4215

March 23, 1981

Honorable Terry Gardiner, Chairman
House Resources Committee
Mail Station 3100
Pouch V
Juneau, Alaska 99811

Dear Representative Gardiner:

The following comments are offered in rebuttal to allegations, by special interest groups, that the primary phase of land clearing (i.e. chaining) renders timber unsalvageable for lumber, logs, or firewood.

As an advisor to the State of Alaska during the 2,000 acre agricultural land clearing trial conducted in Delta Junction in 1977 and 1978 I personally witnessed the effect of chaining on a variety of vegetative types. In addition, nearly all the vegetation on the 60,000 acre Delta Agricultural Project has been chained since 1978.

Chaining simply pulls the trees down to a nearly horizontal position and tends to dislodge the root structure from the soil. Chaining does not destroy the trees. Occasionally, trees will snap off or shatter at the base, but this is rare. The bark is usually marred, however this is an unimportant consideration in any of the previously stated uses. Also, chaining does not result in significant amount of timber being pulled through the soil and thereby becoming encased in silt.

In many instances chaining has improved public access to the timber by providing trails. This has resulted in large quantities of firewood, house logs, lumber, posts and rails being salvaged on the Ag Project here in Delta. I cannot imagine the situation being significantly different in other areas.

Sincerely,

Don Quarberg
Ag Agent

DO/pd/mr

STATE OF ALASKA

DEPARTMENT OF NATURAL RESOURCES -

DIVISION OF FOREST, LAND AND WATER
MANAGEMENT, NORTHCENTRAL DISTRICT

MEMORANDUM

TO: Honorable Terry Gardiner
Chairman, State House Resources Commission
Mail Station 3100, Pouch V
Juneau, Alaska 99811

FROM: George P. Fortier
Area Forester
Delta Area Office
Division of Forest, Land & Water Management

DATE: March 23, 1981

TELE: 895-4226

SUBJ: Forest material salvage: position taken by your Committee
against use of chain during land-clearing operations. Re-
quested by Glen Franklin of Special Projects Office, for my
comment this issue.

Having observed land clearing operations since inception of the Delta project, I would offer the following observations concerning use of the heavy chain as a preliminary land-clearing operation:

1. Chaining is compatible with all wood-salvage operations practiced in the Delta Area to the best of my knowledge. If accomplished when roots are not anchored by frost, neither deciduous nor coniferous stems are seen to shatter if sound.
2. Such stem-damage as may occur should be less than that found in shear-harvest operations.
3. Salvage costs should not be increased by chaining, due to "trade-off" of new access (patterned) trails against somewhat entangled stems.
4. One finds no degradation of stem quality due to alleged dragging, which does not occur.

In summary, I as a professional forester, see no substantial reason to oppose the chaining operation on forest which might be scheduled for successive lumber or firewood salvage.

GFF/sk/mm

I. The present clearing process.

Land at Delta Junction, the state's most recent agricultural project, has been cleared with primary regard to quickly allowing grain planting on large parcels of land. For any project like Delta, virtually simultaneous clearing throughout the area is required. To get started, only immediate large-scale production can economically support the roads, equipment sales outlets, grain processing and marketing facilities modern agriculture needs.

A good team of two bulldozers can clear two acres an hour. They start by dragging a heavy chain between them, both ways through a stand of trees. The uprooted stumps, as well as trunks, roots, soil and moss are then pushed into berm rows at an edge of the field.

To cover costs of clearing Delta, the state has loaned farmers \$165 per acre for 50,000 acres leveled in the past two years.

Haste, however, has made waste. Salvage, left to the individual farmer, is haphazard: some of the bigger trees are cut down ahead of the bulldozers and used in portable sawmills. A small portion of the berm piles are sources for hand-cut firewood. But huge amounts of biomass remain, posing a fire hazard.

Seven uncontrolled forest fires within the project have cost the state more than \$5 million to fight during the past two years. It is not known to what extent these fires could have been limited had the berm rows been removed.

A \$35,000 study conducted in 1979 by Battelle Laboratories for the State Division of Energy concluded that as a first option, the remaining Delta biomass could economically be chipped and used as a supplement to coal in existing electrical boilers in the Fairbanks area. Other options requiring greater capital investment included using the wood for small-scale power generation or for methanol or ammonia production. No action has been taken as a result of this study, which received but limited circulation.

The Battelle Study also recommended that an \$800,000 Mobile Harvester and Chip Forwarder be considered for future clearing. Built by Nicholson Manufacturing, the machines can cut and chip standing timber at one acre per hour. The system is expected to provide chips at \$4 to \$12 a ton from standing timber, reducing the clearing cost by about \$100 an acre. Stump removal costs are excluded from these savings. The state Agricultural Action Council is considering asking the legislature to purchase the machine for the Pt. MacKenzie Project, since conventional clearing costs there have risen to an estimated \$185-200 an acre. Farmers will be loaned \$200-240 per acre for land preparation.

Use of trees to be cleared from Alaska agricultural lands to develop a new wood-fiber industry: a proposal for state policy.

Mead Treadwell
Comex Alaska
December 20, 1980

1131 West Fifth Avenue
Anchorage, AK 99501
907/276-7763
617/498-5317

Presented to the Alaska State Senate under work conducted in conjunction with Sen. Mike Colletta, Majority Leader

Abstract:

Alaska, which plans to dedicate up to two million acres to agriculture during the rest of this century, should not continue to allow cleared trees to rot as waste. This paper proposes whole-tree, in-the-field chipping as an alternative system of land clearing for future agricultural projects. Wood chips can help cover the cost of clearing when sold to supplement coal in utility boilers. New systems have been developed by the U.S. Forest Service to segregate bark from clean chips. Segregating the chips before burning them as fuel creates higher profits since the clean chips can be sold for pulp on the world market. Finally, given the quantity of chips available with Interior Alaska's agriculture potential, there is little more government's agricultural planners may need to do to create an interior Alaska structural particleboard industry than to simply guarantee a long-term supply of the timber resource. A land clearing process which now costs the state and its farmers more than \$200 an acre could be not only self-liquidating, it could also provide new permanent jobs and lower construction costs.

before or after chipping, depending on the end use of the product. Capital cost of this system, which includes a feller-buncher, two grapple-skidders, a delimeter/debarker, a front end loader and two chipvans is estimated at \$850,000.

III. Economic constraints of a change.

Better use of agricultural land timber will require tremendous investment and a certain risk on the part of private industry. New harvesting equipment to clear land without destroying the value of the trees will cost approximately \$1 million for development with the projected size of Tokchaket. A 20 ton-per-hour bark segregator system is estimated to cost \$200,000 with operating costs of less than one dollar per input ton. Going the full step, with construction of a structural particleboard plant, is estimated to cost between \$12 and \$20 million.

Payback, on the other hand, remains an open question. Markets, small now, can be expected to grow for instate fiberboard. Construction at Susitna, for instance, will have a significant impact on the demand for plywood or a substitute. Demand already exists for wood-chips as fuel and pulp.

At present, the largest constraint on the development of a wood fiber industry is not money, it is supply. Government, as a prudent landowner, must recognize that if it wants to see development of a new industry concurrent with agriculture it must make a commitment large enough to ensure financing of plant and equipment. Such a guarantee is no different from the sales made to stimulate instate processing of petroleum resources. As well, a commitment now would help ensure the continued expansion of agriculture in years to come.

As a next step for government, it is important to balance the high costs to the state of clearing and firefighting attributable in part to the current technique of felling trees with whatever aid might be considered for a new harvest and processing method. Industrial development using a new process entails certain risks; government may decide to share in those risks for the greater good.

Industry's role must be to seek out the opportunities for wood product development with agricultural clearing. There will come a time when huge parcels of timber will only be available with large regeneration costs; the presence of agriculture is in effect a subsidy for this new industry.

IV. Conclusion

The references cited at the end of this paper are meant to be consulted. Compiled predominantly at a cost to the taxpayers, they contain the economic facts which back up the ideas contained here. Hardly another study is needed. We already know the value to utilities of burning

II. The Tokchaket Proposal.

The land at Tokchaket, the state's third major agricultural project, will be cleared near Nenana, beginning late in 1981. The project planners intend to make land clearing costs as self-liquidating as possible. Furthermore, the City of Nenana is seeking the development of a diversified wood products industry to use the wood cleared from the Tokchaket lands.

Depending upon the amount of capital invested, three graduated steps are possible to add value to a supply of wood which would otherwise be wasted:

1. Wood chips for fuel in electric boilers. Municipal and military boilers in both the Fairbanks and Anchorage areas have the ability to supplement their use of coal with wood chips with only minor additions to their loading capacity.

2. Pulp chips for export from the State. Currently, pulp chips exported from Alaska are produced after debarking larger logs brought to a stationary mill. Newly developed processes for removing bark from the clean whole-tree chips have been projected to pay for themselves in fuel sales alone. Thus a chip fuel operation which adds a "sifter" can obtain clean, marketable pulp grade chips.

3. Use of clean wood fiber for particleboard manufacture. A world-scale structural particleboard plant requires an approximate annual green wood supply of 100,000 tons. Using a conservative estimate of ten tons per cleared acre, only 10,000 acres per year of trees would be needed to support a particleboard plant. Out-of-state markets, given that Alaska's current use of structural boards and plywood is much less than the output of an optimally sized plant, are yet undetermined.

The planners of the Tokchaket agricultural project will seek proposals from companies interested in clearing and making use of the timber on two contiguous townships comprising 46,080 acres. These two townships are the first stage of an agricultural development which will eventually cover 175,000 acres or more.

A first step toward saving the trees from waste is a decision on the harvesting method. Besides the two machine system mentioned above, a more traditional means of whole-tree chipping is to fell trees with a feller-buncher and "skid" them to a stationary chipper. Debarking can occur



WASHINGTON IRON WORKS

DIVISION of FORMAC INTERNATIONAL, INC.

1500 Sixth Ave. South • Seattle, Wa. 98134 • Phone (206) 823-1292 • Cable Address "FRINK"

August 22, 1980

Mr. Mead Treadwell
1131 West 5th Avenue
Anchorage, Alaska 99501

Dear Mr. Treadwell:

I enjoyed our conversation concerning ways to make use of the wood resource becoming available as a result of Alaska's agricultural expansion program. To slash and burn two million acres of spruce, aspen and birch would certainly be a terrible waste. The manufacture of one or more of the reconstituted wood panel products is one of the more promising approaches for making use of this valuable resource.

Waferboard or Oriented Strand Boards (OSB) would make excellent use of the aspen and birch and could use some of the spruce. These boards could replace some of the 30 million square feet of plywood now imported into Alaska.

There should also be a market for these boards along the west coast of the United States and, perhaps, elsewhere around the Pacific Rim. I'm a bit skeptical of the ability of Alaskan produced board to compete in these markets because of the high labor and material costs in Alaska. You may have a special situation, however, where normal market economics do not apply.

Fiberboard is another reconstituted wood panel product that could be produced. This category of products includes the hardboards ("Masonite"), hardboard exterior siding, and medium density fiberboard (MDF). Some of your production of these boards could probably be used locally, but most of it would have to be exported from Alaska. There is a growing market for these boards all around the Pacific Rim. The Alaskan product in these categories would also suffer from high costs just as would the structural boards

The optimum plant size for Alaska is still open to a lot of questions. We spoke of small plants, but I wonder if a large plant, centrally located at a water, rail and road junction would not turn out to be the most efficient approach. This plant would operate year round, would be large enough to efficiently use the latest technology and would benefit from the usual economies of size, i.e., efficient use of manpower, energy and capital. The biggest unanswered question is one of raw material availability and cost delivered at the plant site. Can you assure an

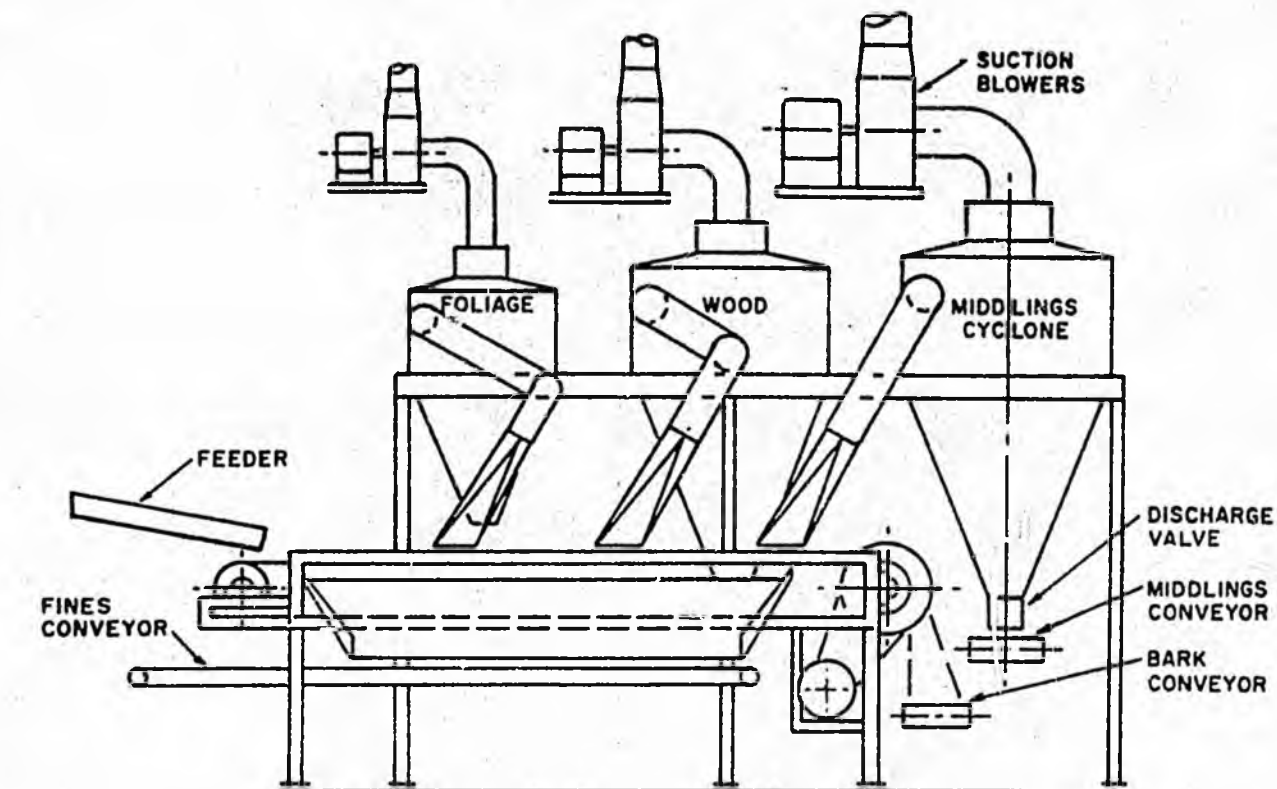

Multiple-stage vacuum airlift segregator. Developed by U.S. Forest Service. (Sturos-i)

wood chips. We already know that a system to segregate bark from whole-tree chips is feasible technically and profitable economically. We already know the costs of building a particleboard plant in Anchorage or Fairbanks and the potential markets to take up our capacity. The questions to ask now center on commitment and specifics: how many trees do we have, how do we want to harvest them, who do we want to be involved, how are we going to pay for it? Time, as well as wood, is a wastin'.

August 22, 1980

annual supply of say 100,000 tons of green wood (150 TPD plant) at a reasonable cost, for a reasonably long plant lifespan (say 10 years)?

I spoke of a 75 TPD plant size as about the smallest we would get involved with. This is true when we are dealing in remote, foreign corners of the world, but Alaska doesn't fall in this category. Your plant site is not really that remote from Seattle, your people and customs are ours, and our commercial practices are identical. I would not want to shut off our involvement just because the optimum plant size turns out to be less than 75 TPD. (I don't think it will).

Without giving any serious thought to plant costs, I can tell you that the capital equipment and process engineering for a 75 TPD MDF plant will cost about \$6,500,000.00. That for a 150 TPD plant will run about \$11,000,000.00. The complete, installed cost of these plants normally would be about twice the cost of the equipment and engineering. I suspect building, utility, installation and erection costs will be higher than "normal" in Alaska, so this 2x multiplier is probably on the low side. For ballpark estimating, you can use the same approximate costs for structural board plants.

I've enclosed our normal selection of sales literature, reprints, etc., which will give you a good picture of Washington Iron Works and what we do. We also work closely with Columbia Engineering International, Ltd., in Vancouver, B.C., who are one of the foremost engineering firms in the reconstituted wood panel field. With them, we offer the full range of services in this field, from early engineering and feasibility studies, through plant and process design to and including the direct manufacture and supply of the major process equipment. Our forte is in fiberboard but we have supplied a number of waferboard plants and are well-qualified in this field also.

Mead, you are involved on a very fascinating program that has elements reaching to all levels of community and industrial planning, involving a wide range of interests and skills. I hope we can be a party in this. Please let me know if we can help in any way.

Sincerely yours,

WASHINGTON IRON WORKS
Division of Formac International, Inc.



David Rudman
General Manager
Miller Hoff Division

Enclosures
cc: J. Chryst
DR/jvn

REFERENCES

- The Anchorage Times. 1980. "State timber sale fizzles as regulations
irk firms," August 20, 1980.
- Battelle Pacific Northwest Laboratories. 1979. Assessment of Biomass
Conversion to Energy for Delta Agricultural Project, Richland,
Washington. Prepared for the Division of Energy and Power Develop-
ment, Department of Commerce and Economic Development, State of
Alaska.
- Bryan, Richard W. 1980. "Harvester cleans plantations, chips small trees
for energy," Forest Industries, July 1980.
- Burlington Electric Department (1979). Wood Fired Electric Power Generation,
Burlington, Vermont.
- Fairbanks Industrial Development Corp. 1977. Feasibility of Structural
Particleboard Manufacture in Alaska, Fairbanks, Alaska. Study
conducted by the U.S. Forest Service and Leonard Guss Associates, Inc.
- Helms, Steven A. 1978. Considerations in Selecting Wood as an Immediate
Source of Reliable and Economical Energy for Military Installations,
U.S. Army Facilities Engineering Support Agency, Technology Support
Division, Fort Belvoir, Virginia.
- Smith, Richard D. 1980. Potential Economic Development of Forest
Resources in Interior Alaska (Draft), University of Missouri,
Columbia, Missouri. Prepared for the USDA Forest Service, Pacific
Northwest Forest and Range Experiment Station, Portland, Oregon.
- Sturos, John A. 1978. Bark, Foliage, and Grit Removal from Whole-tree
Chips - Results and Economics, USDA Forest Service, North Central
Forest Experiment Station, Houghton, Michigan.
- Sturos, John A. and Richard E. Dickson, "Fiber, Fuel, and Food from Whole-
tree Chips," USDA Forest Service, North Central Forest Experiment
Station, Houghton, Michigan.

KANDIK CONSTRUCTION, INC.
P.O. Box 60583
Fairbanks, Alaska 99706

March 14, 1981

TO: Mr. Bill Ward
RE: Bid Proposal on Tract 23
LOCATION: Point MacKenzie Agricultural Project

This quote pertains to logged off areas where stumps will be encountered. The stacking price will be \$450.00 per acre. This quote represents a \$258.00 increase due to the excessive time involved in stump removal.

These figures were obtained by actual work performed in the logged off areas.

If any information other than the above is needed, please feel free to contact us at your convenience.

Sincerely,

Bud LaFon

GDL:jdy/mn

1 DURWOOD J. ZAEKE
2 Sierra Club Legal Defense Fund, Inc.
3 419 6th Street, Suite 321
4 Juneau, Alaska 99801
5 (907) 586-2751

6 IN THE SUPERIOR COURT FOR THE STATE OF ALASKA

7 THIRD JUDICIAL DISTRICT AT ANCHORAGE

8 Harley Brotherton, et. al.,)
9 Plaintiffs,)
10 v.)
11 Department of Natural Resources) No. 3AN-81-1541 Civil
12 et. al.,)
13 Defendants)

14 STIPULATION AND ORDER FOR DISMISSAL

15 WHEREAS, timber resources are among the state's most
16 valuable resources;

17 WHEREAS agricultural projects sometimes require the
18 clearing of valuable timber from state lands; and

19 WHEREAS clearing for agricultural projects involves
20 the potential for wasting valuable timber resources:

21 NOW THEREFORE, The Department of Natural Resources of
22 the State of Alaska, the Agricultural Action Council of the
23 State of Alaska, and the plaintiffs in Brotherton, et. al.,
24 v. Department of Natural Resources, Civil No. 3AN-81-1541,
25 by and through their attorney Durwood J. Zaelke, do hereby
26 stipulate as follows:

27 (i) Any and all loans of state money for clearing the
28 Pt. MacKenzie agricultural project shall include a condition
29 requiring the winners of the Pt. MacKenzie land lottery to
30 offer the marketable, commercial timber resources on their
31 lands to the highest bidder at a public auction duly noticed,
32 and either to accept such bid or to reject it and purchase
the timber themselves at the value established by the highest
bid; if the highest bid is accepted, the lottery winners

1 shall provide the longest practical time for removing the
2 timber resources, consistent with the schedule required by
3 each farmer's approved development plan;

4 (ii) the value of marketable; commercial timber resources
5 shall be included in all future disposals of state agricultural
6 lands, except those lands which are not suitable for timber
7 harvesting;

8 (iii) the costs of suit, including attorneys' fees in the
9 amount of \$2,720 (68 hours x \$40/hour), in Brotherton,
10 et. al., v. Department of Natural Resources, Civil No. 3AN-
11 81-1541, shall be paid by defendants;

12 (iv) The action entitled Brotherton, et. al., v. Depart-
13 ment of Natural Resources, Civil No. 3AN-81-1541, shall be
14 dismissed with prejudice, said dismissal to be lodged by
15 defendants.

16 
17 Durwood J. Zaelke DATED: 3/10/81
18 Attorney for Plaintiffs

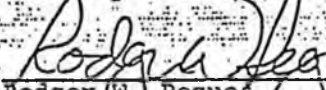
19 
20 Rodger W. Pegues DATED: 3/10/81
21 (for Barbara Mirable)
22 Attorney for Defendants

23 
24 Geoffrey Haynes DATED: 3/10/81
25 Deputy Commissioner
26 Department of Natural Resources

27 
28 Bob Palmer DATED: 2/11/81
29 Agricultural Action Council
30
31
32

