

HB

390

HB 390 return to Clerk's office
on 1/25/80 for SS

AGO 126056

USE

mt

COMMITTEE REPORT

(9)

HOUSE

1/25/80

FURTHER: JUDICIARY

Date: _____

Mr. Speaker:

The Committee on RESOURCES has had SS HB 390

"An Act relating to boating safety."

under consideration and (a majority of the committee) (the committee) reports it back with the following recommendations:

- do pass do not pass
- do pass with attached amendments(s)
- replace with CS for _____ same title
 new title
- and recommends _____
- AND attaches a "Letter of Intent" New Fiscal Note
- reports it back without recommendation
- referred to the _____ Committee

MEMBERS SIGNING
DO PASS

MEMBERS HAVING
OTHER RECOMMENDATIONS:

CHAIRMAN

65-28
Buchholdt

ALASKA STATE LEGISLATURE	
ELEVENTH Legislature	SECOND Session
SPONSOR SUBSTITUTE HOUSE BILL	NO. SSHB 390
By BUCHHOLDT	
"An Act relating to boating safety."	
Boating safety	
Introduced in the House 1/25, 1980	

HISTORY IN THE HOUSE	
1980	Read first time and referred to Committee on Resources and Judiciary
Jan. 25	Reported back with recommendation that
	Read second time and
	Read third time and
	PASS Effective Date
	Yeas Yeas
	Nays Nays
	Absent Absent
	Excused Excused
	Reconsideration
	PASS Effective Date
	Yeas Yeas
	Nays Nays
	Absent Absent
	Excused Excused
	Reported correctly engrossed
	Signed by Speaker
	Sent to Senate
CHIEF CLERK OF THE HOUSE	

HISTORY IN THE SENATE	
19	Read first time and referred to Committee on
	Reported back with recommendation that
	Read second time and
	Read third time and
	PASS Effective Date
	Yeas Yeas
	Nays Nays
	Absent Absent
	Excused Excused
	Reconsideration
	PASS Effective Date
	Yeas Yeas
	Nays Nays
	Absent Absent
	Excused Excused
	Reported correctly engrossed
	Signed by President
	Returned to House
SECRETARY OF THE SENATE	

HISTORY IN THE HOUSE	
19	Received from Senate
	Concurred in Senate amendment thus adopting: VOTE
	Failed to concur in Senate amendment; asked Senate to recede VOTE
	Senate receded from amendment VOTE
	Senate failed to recede from amendment VOTE
	CC appointed by House
	CC appointed by Senate
	CC adopted by House VOTE
	CC adopted by Senate VOTE
	To enrolling
	Reported correctly enrolled sent to Governor
	by Governor
	Filed with Lt. Governor
	Chapter No.

ALASKA STATE LEGISLATURE

ELEVENTH Legislature SECOND Session

SPONSOR SUBSTITUTE HOUSE BILL NO. SSHB 390

By BUCHHOLDT

"An Act relating to boating safety."

Boating safety

Introduced in the House 1/25, 1980

HISTORY IN THE HOUSE

19 80 Read first time and referred to Committee on

Jan. 25 Resources and Judiciary Reported back with recommendation that

Read second time and

Read third time and

PASS Effective Date
Yeas Yeas
Nays Nays
Absent Absent
Excused Excused

Reconsideration
PASS Effective Date
Yeas Yeas
Nays Nays
Absent Absent
Excused Excused
Reported correctly engrossed
Signed by Speaker
Sent to Senate

CHIEF CLERK OF THE HOUSE

HISTORY IN THE SENATE

19 Read first time and referred to Committee on

Reported back with recommendation that

Read second time and

Read third time and

PASS Effective Date
Yeas Yeas
Nays Nays
Absent Absent
Excused Excused

Reconsideration
PASS Effective Date
Yeas Yeas
Nays Nays
Absent Absent
Excused Excused
Reported correctly engrossed
Signed by President
Returned to House

SECRETARY OF THE SENATE

HISTORY IN THE HOUSE

19 Received from Senate

Concurred in Senate amendment thus adopting: VOTE

Failed to concur in Senate amendment; asked Senate to recede VOTE

Senate receded from amendment VOTE

Senate failed to recede from amendment VOTE

CC appointed by House

CC appointed by Senate

CC adopted by House VOTE

CC adopted by Senate VOTE

To enrolling Reported correctly enrolled Sen' to Governor

by Governor

Filed with Lt. Governor

Chapter No.

6528
Buchholdt



Alaska State Legislature

House

HOUSE RESOURCES COMMITTEE

FISH & GAME ISSUES

Alvin Osterback, Chairman

Pouch V State Capitol
Juneau, Alaska 99811
(907) 465-3715

HEARING NOTIFICATIONS

BILL	DATE INFORMED	LETTER/PHONE	INFORMED	HEARING DATE
SSB 390 Boating Safety	2/22/80	call	Rep. Thelma Buchholdt, Sponsor	2/25
	2/22	586-7300	Coast Guard: David Illuminate to testify	2/25
	2/22	486-5438	Harbor Masters Assoc. - (Kodiak) George McCordle, Sec.	2/25
	2/22		Dept. of Public Safety Mike Clemens to testify	2/25



(907) 886-7198

SS

Mr. Ellon

7300
36-100

CAPT JOHN C HANSON
CHIEF, MARINE SAFETY DIVISION
SEVENTEENTH COAST GUARD DISTRICT

UNITED STATES
COAST GUARD

P O BOX 35001
SIKOTIA ALASKA 99512

approx. \$ 250,000 - 300,000
would go to Alaska
first year

GB/TP

96TH CONGRESS
1ST SESSION

S. 1957

To amend the Federal Boat Safety Act of 1971 to improve recreational boating safety and facilities through the development, administration, and financing of a national recreational boating safety and facilities improvement program, and for other purposes.

IN THE SENATE OF THE UNITED STATES

OCTOBER 30 (legislative day, OCTOBER 15), 1979

Mr. EAGLETON introduced the following bill; which was read twice and referred to the Committee on Commerce, Science, and Transportation

A BILL

To amend the Federal Boat Safety Act of 1971 to improve recreational boating safety and facilities through the development, administration, and financing of a national recreational boating safety and facilities improvement program, and for other purposes.

- 1 *Be it enacted by the Senate and House of Representa-*
- 2 *tives of the United States of America in Congress assembled,*
- 3 *That this Act may be cited as the "Recreational Boating*
- 4 *Safety and Facilities Improvement Act of 1979".*

RECEIVED

Office of...

1 approved State vessel numbering system is necessary
2 for full eligibility for Federal funds allocated and dis-
3 tributed under this section;

4 “(2) a cooperative boating safety assistance pro-
5 gram with the Coast Guard in that State;

6 “(3) sufficient patrol and other activity to insure
7 adequate enforcement of applicable State boating safety
8 laws and regulations;

9 “(4) an adequate State boating safety education
10 program;

11 “(5) the designation of a State lead authority or
12 agency, which would implement or coordinate the im-
13 plementation of the State recreational boating safety
14 and facilities improvement program supported by Fed-
15 eral financial assistance in that State, including the re-
16 quirement that the designated State authority or
17 agency submit required reports in the form prescribed
18 by the Secretary; and

19 “(6) a facilities improvement program describing
20 boating facility projects, including but not limited to:
21 acquisition of title, or any interest in riparian or sub-
22 merged land; and capital improvement of riparian or
23 submerged land for the purpose of increasing public
24 access to the waters of the United States, and such an-

1 cillary facilities as are necessary to insure the safe use
2 of those facilities.”

3 (c) Allocation and distribution of funds under this section
4 is subject to the following conditions:

5 “(1) Of the total funds available for allocation and
6 distribution, one-third shall be allocated each year for
7 recreational boating safety programs and two-thirds
8 shall be allocated for recreational boating facilities im-
9 provement programs.

10 “(2) Of the funds available for allocation and dis-
11 tribution for recreational boating safety programs, one-
12 third shall be allocated equally among eligible States.
13 One-third shall be allocated so that the amount each
14 year to each eligible State will be in the same ratio as
15 the number of vessels numbered in that State, under a
16 numbering system approved under this Act, bears to
17 the number of vessels numbered in all eligible States.
18 The remaining one-third shall be allocated so that the
19 amount each year to each eligible State shall be in the
20 same ratio as the State funds expended or obligated for
21 the State boating safety program during the previous
22 fiscal year by a State bears to the total State funds ex-
23 pended or obligated for that fiscal year by all eligible
24 States.

1 “(3) Of the funds available for allocation and dis-
2 tribution for recreational boating facilities improvement
3 programs, one-third shall be allocated each year, equal-
4 ly among eligible States. The remaining two-thirds
5 shall be allocated so that the amount each year to each
6 eligible State will be in the same ratio as the number
7 of vessels numbered in that State bears to the number
8 of vessels numbered in all eligible States.

9 “(4) The amount received by any State under this
10 section in any fiscal year may not exceed one-half of
11 the total cost incurred by that State in the develop-
12 ment, administration, and financing of that State's rec-
13 reational boating safety and facilities improvement pro-
14 gram in that fiscal year.

15 “(5) No allocation or distribution of funds under
16 this section may be made to any State for the mainte-
17 nance of boating facilities under an approved State rec-
18 reational boating safety and facilities improvement pro-
19 gram.

20 “(6) The Secretary is authorized to expend from
21 the funds available for allocation or distribution in any
22 fiscal year those sums, not to exceed two percent of
23 the funds available, as are necessary for the adminis-
24 tration of this Act.”.

25 (5) Section 27 is amended to read as follows:

1 "ESTABLISHMENT OF NATIONAL RECREATIONAL BOATING
2 SAFETY AND FACILITIES IMPROVEMENT FUND

3 "SEC. 27. There is in the Treasury of the United States
4 a fund known as the National Recreational Boating Safety
5 and Facilities Improvement Fund, consisting of such amounts
6 as may be credited to it as provided in this section. There
7 shall be covered into the fund the amounts specified in sec-
8 tion 209(f)(5) of the Highway Revenue Act of 1956 (70 Stat.
9 397), as amended. Amounts in the fund shall be available, as
10 provided in appropriation Acts, for making expenditures after
11 September 30, 1980, and before October 1, 1984, for the
12 purposes of section 26 of this Act."

13 (6) In section 28 by striking subsections (a) and (d)
14 and redesignating subsections (b) and (c) as (a) and (b),
15 respectively.

16 (7) In section 29 by adding, following the words "boat-
17 ing safety", the words "and facilities improvement" and fol-
18 lowing the words "costs of" the first time they appear, the
19 word "land,".

20 (8) Section 30 is amended to read as follows:

21 "AUTHORIZATION OF APPROPRIATIONS FOR STATE REC-
22 REATIONAL BOATING SAFETY AND FACILITIES IM-
23 PROVEMENT PROGRAMS

24 "SEC. 30. For the purpose of providing financial assist-
25 ance for State recreational boating safety and facilities im-

1 improvement programs, there is authorized to be appropriated
2 \$30,000,000 for each of the fiscal years beginning with fiscal
3 year 1981 through fiscal year 1984, those appropriations to
4 remain available until expended.”.

5 (9) Section 31 is amended—

6 (a) in subsection (a) to read as follows:

7 “(a) Amounts allocated and distributed under sec-
8 tion 26 of this Act shall be computed and paid to the
9 States as follows: The Secretary shall determine,
10 during the last quarter of a fiscal year, on the basis of
11 computations made pursuant to section 29 of this Act
12 and submitted by the States, the percentage of the
13 funds available for the next fiscal year to which each
14 eligible State shall be entitled. Notice of the percent-
15 age and of the dollar amount, if it can be determined,
16 for each State shall be furnished to the States at the
17 earliest practicable time. If the Secretary finds that an
18 amount made available to a State for a prior year is
19 greater or less than the amount which should have
20 been made available to that State for the prior year,
21 because of later or more accurate State expenditure in-
22 formation, the amount for the current fiscal year may
23 be increased or decreased by the appropriate amount.”;
24 and

1 (b) in subsection (c) by adding, following the word
2 "safety" wherever it appears, the words "and facilities
3 improvement".

4 (10) Section 32 is amended—

5 (a) by striking in subsection (a) the words "boat-
6 ing and boating safety" and inserting in lieu thereof
7 the words "boating safety and facilities improvement.";
8 and

9 (b) by adding in the first sentence of subsection (b)
10 following the word "safety" the words "and facilities
11 improvement".

12 SEC. 3. Section 209(f)(5) of the Highway Revenue Act
13 of 1956 (70 Stat. 397), as amended, is amended to read as
14 follows:

15 "(5) TRANSFERS FROM THE TRUST FUND FOR
16 SPECIAL MOTOR FUELS AND GASOLINE USED IN MO-
17 TORBOATS.—The Secretary of the Treasury shall pay
18 from time to time from the trust fund into the recre-
19 ational boating safety and facilities improvement fund
20 provided for in section 27 of the Federal Boat Safety
21 Act of 1971 (85 Stat. 213), as amended, amounts as
22 are determined by him equivalent to the taxes re-
23 ceived, on or after September 30, 1980, under section
24 4041(b) of the Internal Revenue Code of 1954, as
25 amended, with respect to special motor fuels used as

1 fuel for the propulsion of motorboats and under section
2 4081 of that Code with respect to gasoline used as fuel
3 in motorboats. No amounts may be transferred under
4 this section if the transfer would result in increasing
5 the amount in the recreational boating safety and facil-
6 ities improvement fund to a sum in excess of
7 \$30,000,000. The Secretary shall transfer any remain-
8 ing amounts received into the trust fund from the
9 above sources and not transferred in accordance with
10 the foregoing provision, as determined by him in con-
11 sultation with the Secretary of Commerce, into the
12 land and water conservation fund provided for in title I
13 of the Land and Water Conservation Fund Act of
14 1965.".

○



ALASKANS AFLOAT

A BOATING SAFETY
HANDBOOK

WELCOME ABOARD!

Welcome aboard! The course of study you are about to embark upon is the first of its kind to be used in Alaskan schools. Boating means many things to different people—skiing, fishing, sailing, camping and just plain cruising. Boating is now the nation's most popular form of family recreation.

Almost 200,000 boaters enjoy our State waters annually. Unfortunately, some of those who were out to have a good time never made it back. Many boaters are killed or seriously injured each year. In fact, the accident rate in Alaska is the highest in the nation.

We think that you will find this course to be informative, as well as enjoyable. If you put forth the effort to understand the few basic regulations and practices that affect boating in Alaska, you too can enjoy our waterways without becoming an accident statistic.

So, when you take to the water please keep in mind what you learn from this course, and occasionally refreshen yourself, so that you will truly become a Better Alaskan Boater!

Sincerely,



George P. Asche,
Captain
UNITED STATES COAST GUARD
Seventeenth Coast Guard District
Boating Safety Division



STATE OF ALASKA
United States Coast Guard

In cooperation with:
Alaskan Native Health Authorities
The American Red Cross
United States Coast Guard Auxiliary
United States Public Health Service

First printing February 1979

Copyright © 1979 by Outdoor Empire Publishing, Inc.

All rights reserved.

No part of this book may be reproduced in any form or by any person without permission in writing from the publisher.

Outdoor Empire Publishing, Inc.
311 Eastlake Ave. E., P.O. Box C 19800
Seattle, WA 98109

Printed in U.S.A.

TABLE OF CONTENTS



Boating Safety	4
-----------------------------	---

Part I Boats

Chapter 1	Classification	8
Chapter 2	Watercraft	9
	Sailor's Worksheet 1	12
Chapter 3	Sailboats	18
Chapter 4	Boat Hulls	21
Chapter 5	Registration and Numbering	22
Chapter 6	Responsibility	26
	Sailor's Worksheet 2	30



Part II Equipment

Chapter 7	Personal Flotation Devices	33
Chapter 8	Lights	36
Chapter 9	Additional Equipment	36
Chapter 10	Fire	37
	Maintenance	41
	Sailor's Worksheet 3	42
Chapter 11	Trailing	43
	Sailor's Worksheet 4	46



Part III Navigation

Chapter 12	Navigational Aids	49
	Sailor's Worksheet 5	51
Chapter 13	Compass	52
Chapter 14	Weather	53
	Sailor's Worksheet 6	56



Part IV Getting Underway

Chapter 15	Rules of the Road	58
	Sailor's Worksheet 7	62
Chapter 16	Knots	64
Chapter 17	Preparation	65
Chapter 18	The First Cruise	67
Chapter 19	Mooring	68
Chapter 20	Anchoring	69
	Sailor's Worksheet 8	70

Part V Emergency

Chapter 21	Accidents	73
	Sailor's Worksheet 9	76
Chapter 22	First Aid	77
	Sailor's Worksheet 10	83
	Glossary	84
	What Makes A Good Skipper?	87



BOATING SAFETY

Boating as an occupation and family sport is growing with each passing day. Our modern industrial technology has given us more leisure time than ever before in our history and, as the population continues to grow, demands for food also mount, thus increasing the need for fishermen.

The purpose of this course is to introduce to all owners and operators of water craft safety requirements and safe practices in the operation and navigation of their boats. The secret of boating safety is keeping out of trouble rather than getting out of trouble after you get into it.

Unfortunately, it is a fact that some of our boaters do manage to get into trouble afloat and, in some cases, end up as "statistics" in the local press.

In 1977, for example, nationally there were 6,816 reported boating accidents involving 8,554 vessels. These accidents resulted in 1,054 fatalities, 1,332 personal injuries and over 11.5 million dollars in property damage. These numbers aren't quite as impressive in Alaska but when you consider that we have 1.7% of the national fatalities with only 0.3% of the registered boats in the nation, you can see we have more than our share. A lot of lives, injuries and money! Can this be prevented? The answer is an emphatic yes! Most boating accidents are the result of a lack of basic knowledge on the part of the boater. Common causes of boating accidents are:

1. Engine too powerful or too heavy
2. High speed turns
3. Overloading
4. Riding on the bow or gunwales
5. Damage from wakes
6. Lack of Personal Flotation Devices
7. Explosion and fire resulting from fuel leaks or spills.
8. Drinking and improper use of drugs

Capsizing

The record shows that year after year more lives are lost as the result of vessels capsizing than any other type of casualty. In most cases it's the operator who is to blame. Improper loading and overloading are the principal reasons for capsizing and ignoring weather warnings ranks next.

When loading your boat, weight should be evenly distributed from *bow* (front) to *stern* (back) and *athwartships* (from side to side). The more weight you put into a boat, the deeper it sinks into the water, thus reducing the amount of *freeboard*. The more you

reduce the freeboard, the greater the tendency to swamp or capsize. If a boat is over-loaded or improperly loaded it will usually be difficult to steer. Many boats today have a capacity plate, generally on the instrument panel where it can be easily seen, which indicates its weight-carrying capacity.

Water Conditions

The first factor to consider is the anticipated sea-state or water conditions. It is logical to deduce that if rough water is expected, less weight should be carried. At selected locations in and near boating areas, storm warnings may be displayed by flag hoists or lights. Display points may be Coast Guard stations, marinas, lighthouses or municipal piers.

Activities

The second factor to consider would be the activity in which you expect to engage while under way. Standing up in a small boat is not especially dangerous if it is done carefully in calm water conditions and if the boat is not too heavily laden. By standing up you will change the center of gravity of the boat and if the hull is being buffeted about appreciably, it could cause the boat to capsize or for you to fall overboard. Other factors would be the weight of the equipment, fuel, tools, food and other gear which will be carried.



(Photo courtesy SEATTLE TIMES)

Improper Loading — Result Swamping

Falls Overboard

Falls overboard and vessel sinkings are the second and third major types of casualties resulting in boating fatalities. As a boat operator, you must recognize these dangers and learn how to avoid them. As stated previously, improper loading and overloading are the principal causes of falls overboard and vessel capsizings.



Collisions

The most common type of accident while cruising is collision with another vessel. Failure to maintain an efficient forward lookout, or careless and negligent operation on the part of the operator, are the major causes of most collisions. The second most common type is collision with a fixed object. There is little excuse for this type of accident but in 1977, 3,619 vessels collided with other vessels and 1,063 vessels collided with fixed objects.



Fires and Explosions

Fires and explosions resulted in the most property damage in 1977. A number of things can cause a fire aboard your boat. Among these are careless smoking, spontaneous combustion caused by oil or gasoline

soaked rags or paper left aboard (instead of being disposed of on shore), an electrical short, a flame-up of the galley stove or ignition of spilled or leaking gasoline.

Personal Flotation Devices

All federal laws require at least one Coast Guard approved *personal flotation device* aboard and readily available for every person on board the boat. In 1977, over 1,000 persons drowned in boating accidents. Of these, almost half were known to have had personal flotation devices available. Eighty percent of the victims did not use the available devices or used them improperly. Of those who drowned, 20 percent were known not to have had personal flotation devices available and in the case of 30 percent of the victims, it is not known whether or not a personal flotation device was available. Most boaters comply with the law which requires them to have an adequate number of Coast Guard approved personal flotation devices aboard. However, in all too many cases these devices were stowed in places where they could not be grabbed quickly when needed. In numerous other instances, nobody knew how to use them. Personal flotation devices are effective only when available and properly used. These devices should be treated as though your life may well depend on them.



Hunting and Fishing

Hunters and fishermen often use their boats as a form of conveyance rather than for boating

enjoyment. Many of them are not aware of the potential dangers of boating and, as a result, it is estimated that in the last few years hunters and fishermen have been involved in approximately 30 percent of all boating accidents. Hunters and fishermen often become so engrossed in their sport that they forget all about the weather. If they happen to notice the weather, they may think they can beat the weather and make it back safely to shore. Hunters and fishermen are well advised to wait in sheltered waters until sea conditions improve before attempting to return home. It could save their lives!

Fishermen may get fishing lines tangled around the propeller, rudder, outboard engine or anchor line. In attempting to disengage these lines they often lean too far over the side, with the result that falls overboard are commonplace.

A hunter should be careful about standing up in a small boat to shoot. The recoil could knock him overboard. Most high-powered rifles and shotguns recoil considerably and should be fired from a sitting position in a small boat. By using common sense most tragedies might be averted.

Water Skiing

Water skiing is increasing in popularity in all parts of the country. Water skiing is a sport. It takes skill, not showing off, to become a good skier. Horseplay brings with it danger to the boat, the skier and anyone in the area. Showing off is the chief cause of accidents



in what could be the safest water sport. It can be very safe if the skier wears a Coast Guard approved personal location device and the boat operator knows what he is doing.



Skin Diving

An important flag is commonly seen on our waters. It has a red-orange background with a white diagonal stripe from corner to corner. This is the diver's flag. When you see it flying from a boat, or from a float, do not approach too closely or attempt to pass between the flag and the nearby shore. This flag indicates that there are divers down in the area and it requests you to keep clear.

Swimming

Some boaters use their boats as swimming and diving platforms. It is usually best to anchor the boat before the swimming party begins. If yours is a shallow draft boat (one which can float in very shallow water), the wind could cause the boat to drift away at a good rate of speed. One person should remain aboard to act as a life guard and to see that the anchor does not drag. Before anyone dives in, the best swimmer aboard should enter the water cautiously to determine the depth as well as inspect the bottom for underwater obstructions.

Part I

BOATS



CLASSIFICATION

Motorboats

All motorboats are divided into one of four classes according to length. U.S. Coast Guard authorities use these classes to register and number a boat. Equipment required on a boat also varies according to class and type of propulsion.

The four motorboat classes are:

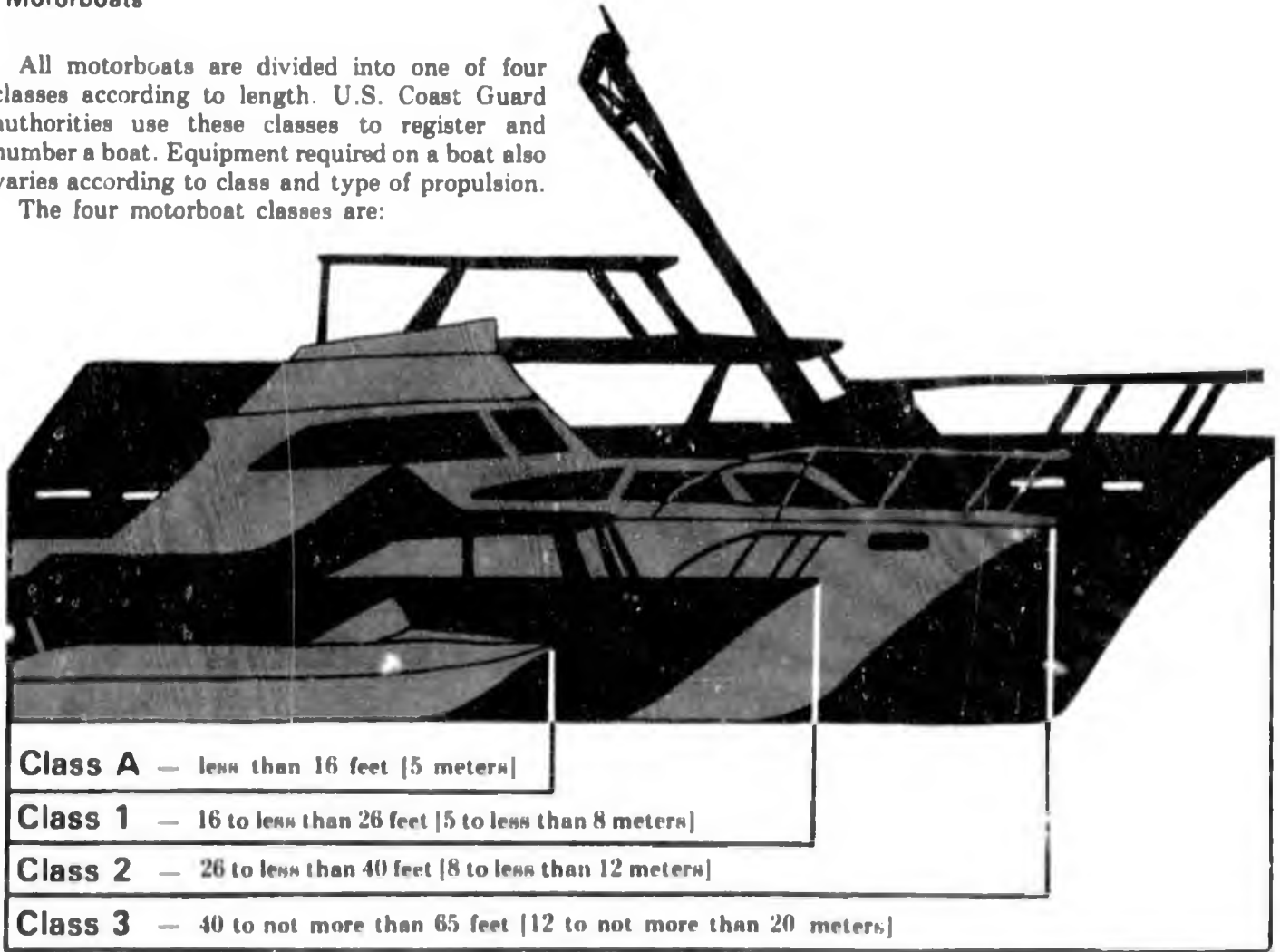

How To Measure Length

A boat's length is measured from end to end, parallel to the centerline. Measurement is from outside planking or plating. Outboard motor brackets, fittings or attachments are not included. Some examples of length measurement are:

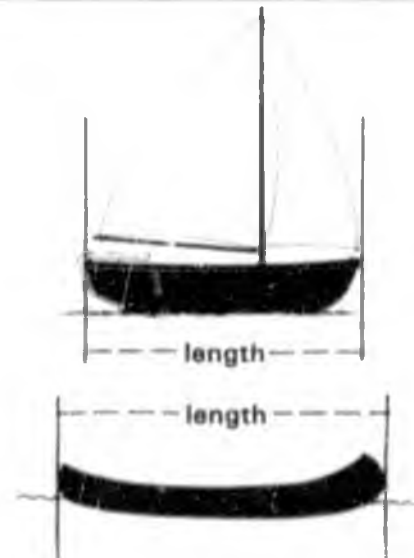
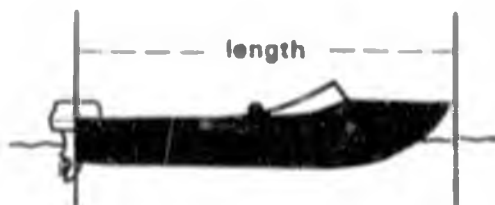

WATERCRAFT

Within each class are many types of boats. A safe boater must consider the craft's size, shape, proportions, seaworthiness, use and capacity. Many boats have motors. Others are used in sports where power is not needed.

There are many personal decisions to make about brand, cost and materials. Wood, steel, aluminum, fiberglass and ferro-cement are all used in boat building. All have good qualities. Choose the right one to fit your boating needs.



Runabouts

The majority of recreational motorboats are under 26 feet (Classes A and 1) and may be powered by an inboard, outboard or inboard/outdrive motor. The runabout is ideal for water skiing, fishing and cruising.



Canoes

Canoes, usually "people-powered," can be equipped with a small, low horsepower motor on a side mount. Canoes are most often double-ended, pointed at both

bow (front) and stern (back). Some have outriggers or motor mounting brackets. Canoes with square sterns that form a motor transom are usually classified as boats with numbers. Canoes are generally round-bottomed. They can be very unstable if not used properly.



Kayaks

Kayaks are also people-powered. Most modern kayaks are constructed of canvas, fiberglass or wood. They are light and strong, gliding easily through the water. Kayaks have closed decks with cockpit areas for one or two people.



Inflatables

Inflatables are made from neoprene coated fabric to protect from heat and saltwater. Inflatables are easy to move from place to place. They can be pumped up quickly with a foot pump. Inflatables are very buoyant and quite stable. They should have several air chambers (or compartments) so that the boat will still float even if one of the chambers is punctured by accident. Be careful not to drag inflatable boats or scrape them on rocks or rough surfaces. Inflatables may be constructed for use with or without power.

WATERCRAFT



Sailboats

Recreational sailing falls into three main classifications: day sailing, cruising and racing. Boat hulls are designed to meet the specific requirements of each category. Many types, sizes, and rigs (sail and mast arrangement) are available to the sailor. Some sailboats also have power. All sailboats respond in the same basic ways to the forces of wind and water.



Cruisers

A cruiser is a motorboat with overnight accommodations. These include sleeping berths (bunks), a dinette, a head (lavatory) and a galley (kitchen).

Cruisers generally start at not less than 18 feet in length and run on up to 50 feet or more. The largest are usually referred to as motor yachts. Two basic types of cruisers are the express cruiser, which has the

main cabin occupying the front half of the boat and a large after deck and steering station in the rear, and the sedan cruiser that features a very long cabin enclosing almost the entire boat.

Express cruisers are better for fishing and activities where a large open deck is important while a sedan cruiser makes a more practical live-aboard boat. Frequently a manufacturer builds the sedan and express models on the same hull with identical power and performance. Either may be equipped with a command bridge.



Day Cruisers

Day Cruisers are small express type cruisers with the forward cabin area limited to a couple of bow bunks and storage area. Many in the 18 to 24-foot sizes have a head and limited galley area. A large open deck makes this type of boat excellent for fishing and other water sports.

WATERCRAFT



Fishing Boats

Sportfishing boats are generally large express cruisers specifically outfitted for fishing in the ocean or large open waters. Commercial fishing boats are likewise outfitted, however, they are built more rugged and less for speed and more for carrying large amounts of fuel and water for several days underway, as well as having large storage bins for the caught fish.



Motor Sailer

Motor sailers are half motorboat and half sailboat. Sails, smaller than those used on a similar sized sail boat supply the power when there is wind, or are used to steady the boat in heavy seas. Medium inboard power, often diesel, gives good cruise speed without assistance from the wind and sails. The beam is generally broad making a deep keel unnecessary for stability.



Motor Yacht

Motor yachts are like luxurious homes on large boat hulls. Most major yachts have large fuel and water tanks for long offshore cruises. Each section, such as galley, head, lounge and staterooms can be equipped with all the shoreside conveniences.

Sailor's Terms

Distinguishing between port (left) and starboard (right) is at once the most basic and most confusing for many students. Remember that "port" and "left" match up as four-letter words, while "right" and "starboard" have more letters. Port and starboard colors follow the same rule: port is red (short); starboard is green (longer). Port, left and red are all short words. Starboard, right and green are longer words.

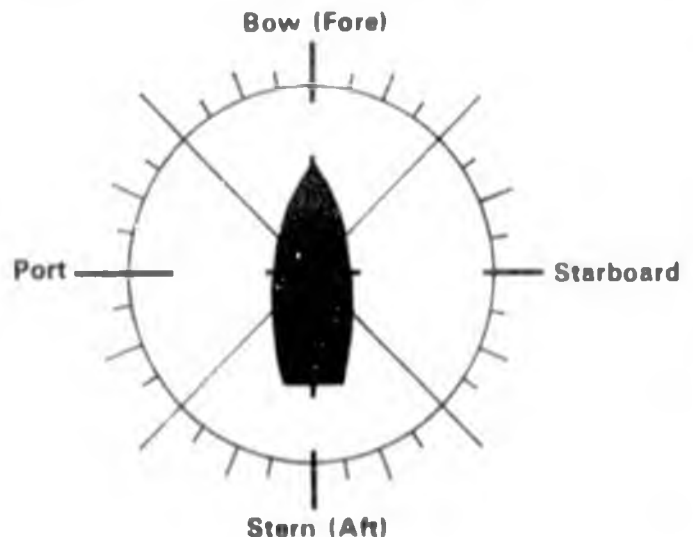

SAILOR'S WORKSHEET I

1. What is a motorboat? _____
2. Boats are classified according to _____
3. Class A boats are less than _____ feet long.
4. Class 3 boats are _____ feet or over.
5. Materials used for making boats include: _____
6. What are the best materials for making a boat? _____
7. Identify Stern, Bow, Port, Starboard, Fore, Aft.

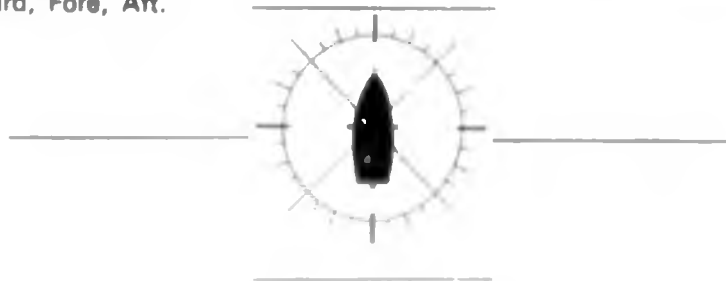

8. Motors are most often located in the _____ of boats.
9. Give one advantage and disadvantage of an inflatable boat.
Advantages: _____
Disadvantages: _____
10. A boat's port side is on the _____
11. A boat's starboard side is on the _____
12. Identify the following boats:







SAILOR'S LANGUAGE

Label the parts of this motorboat by matching the numbers on the list with those on the diagram.

1. Beam
2. Freeboard
3. Waterline
4. Draft
5. Prop
6. Chines
7. Rail
8. Outboard Motor
9. Stern Light-white
10. Steering Wheel
11. Chock (open)
12. Eye
13. Combination Light-red, green
14. Windshield
15. Cleat

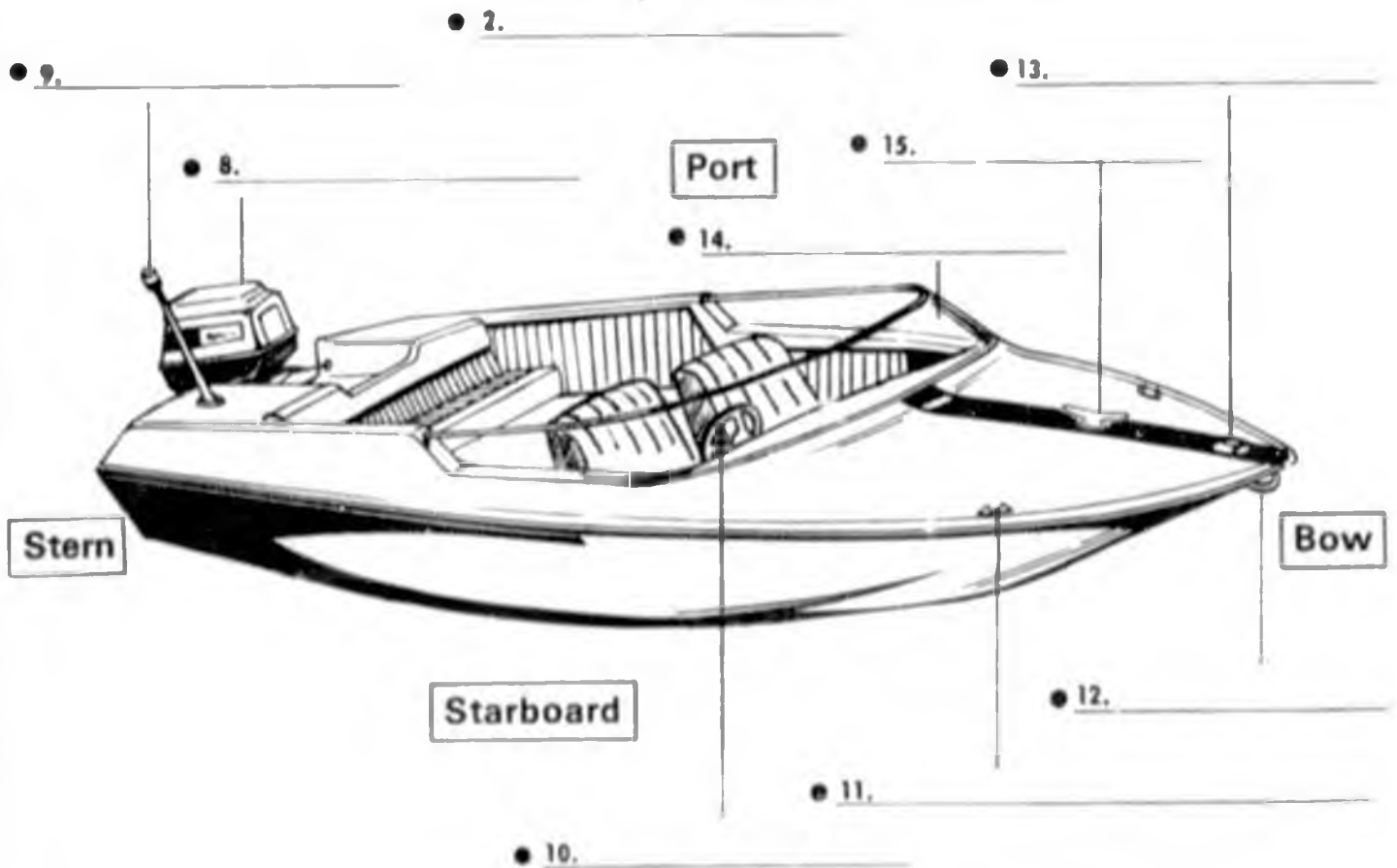
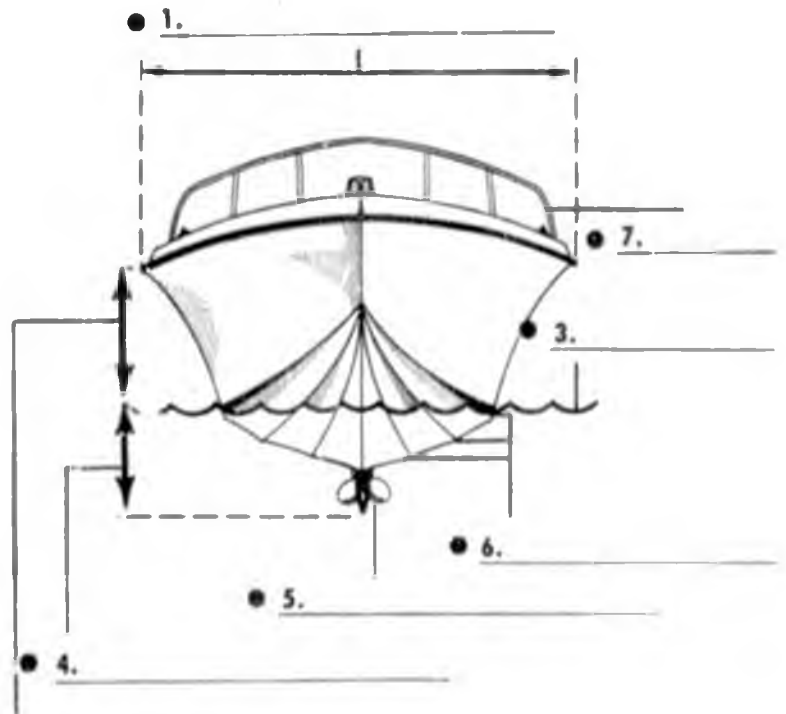

SAILOR'S LANGUAGE

Label the parts of the kayak, kayak paddle and inflatable by matching the numbers on the list with those on the diagram.

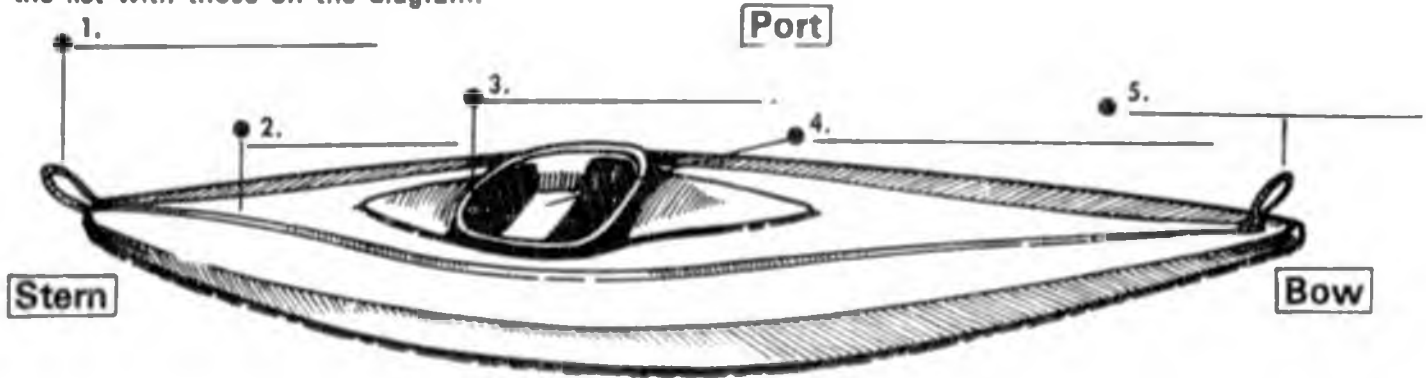

Kayak

- 1. Stern grab loops
- 2. Deck
- 3. Molded cockpit lip
- 4. Cockpit seat
- 5. Bow grab loops

Kayak Paddle

- 1. Shaft
- 2. Blade

Starboard



Inflatable

- 1. Air valve (front chamber)
- 2. Grab line
- 3. Transom mounting brackets
- 4. Seats
- 5. Air valve (rear chamber)

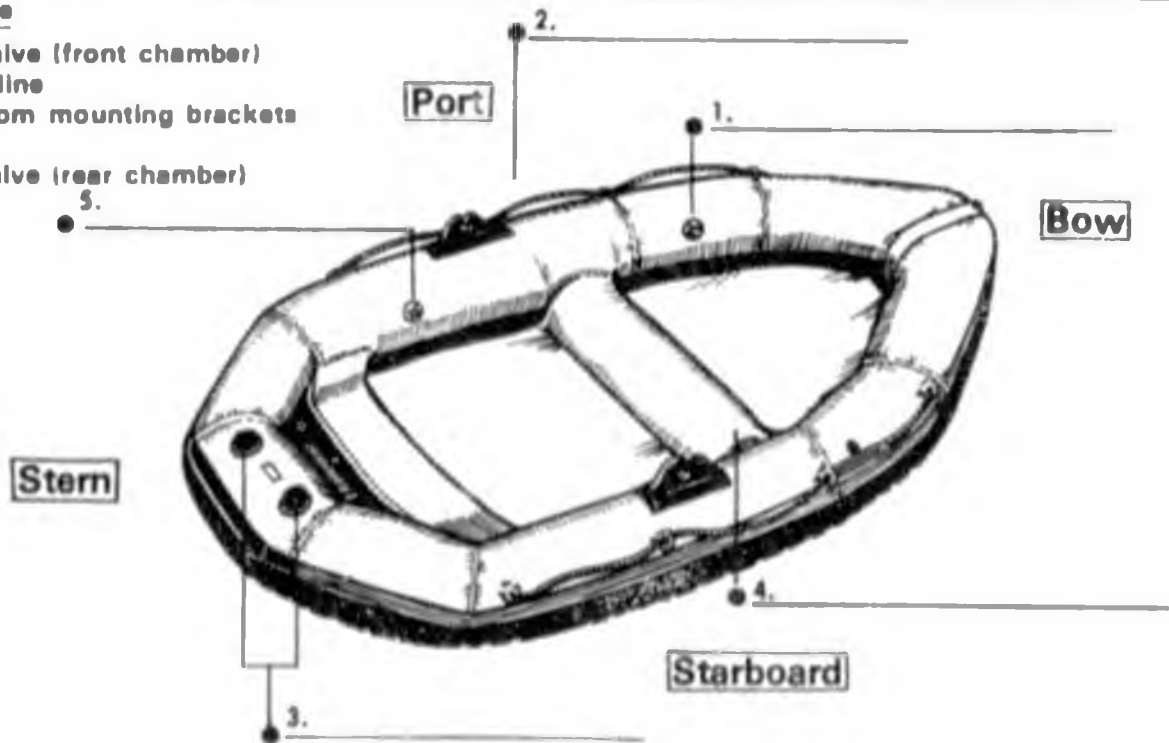

SAILOR'S LANGUAGE

Label the parts of this canoe by matching the numbers on the list with those on the diagram.

1. Ribs
2. Keel
3. Thwart
4. Gunwale
5. Deck
6. Bow Painter
7. Stern Painter

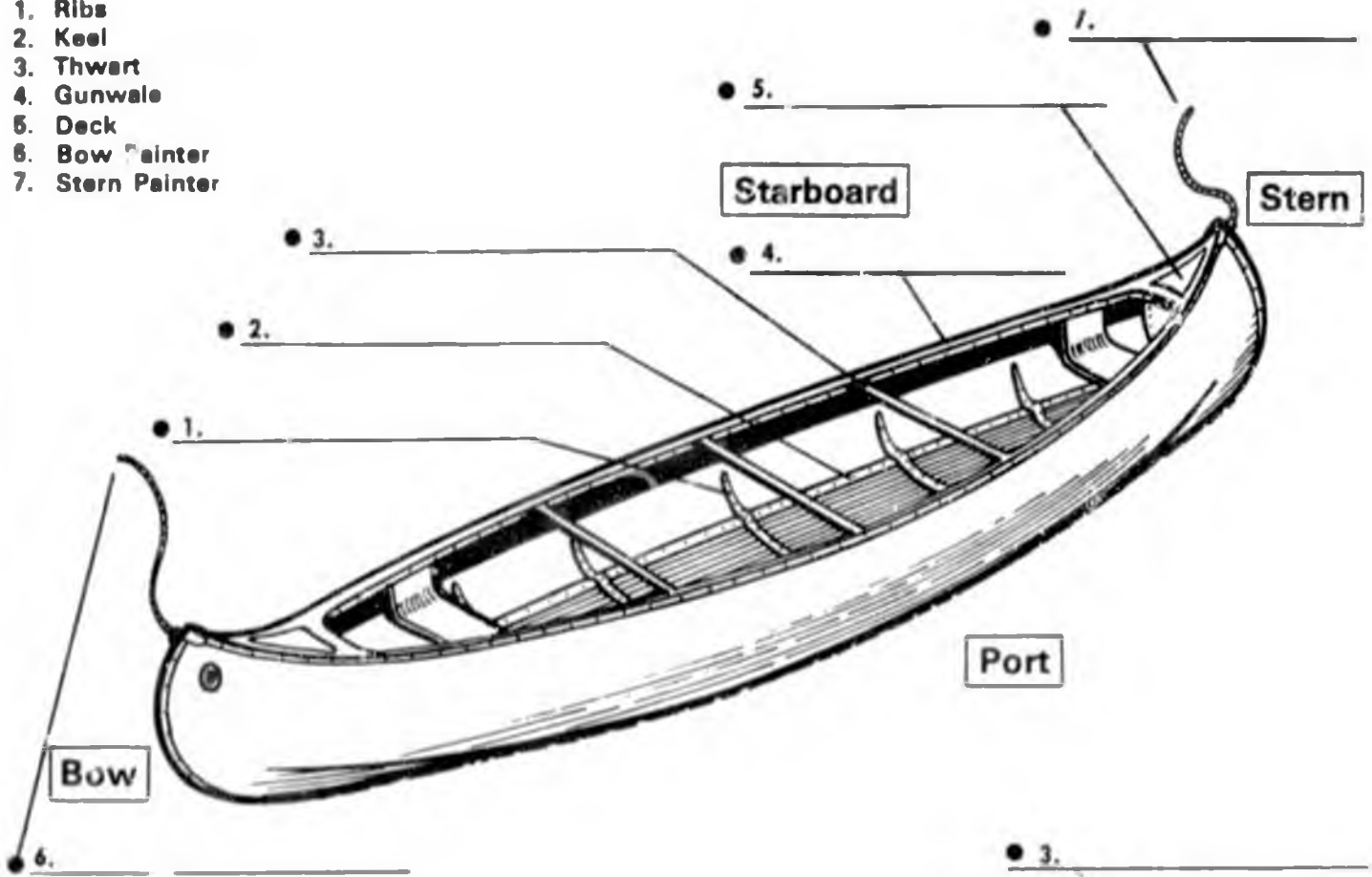

Label the parts of this paddle by matching the numbers on the list with those on the diagram.

1. Shaft
2. Blade
3. Grip

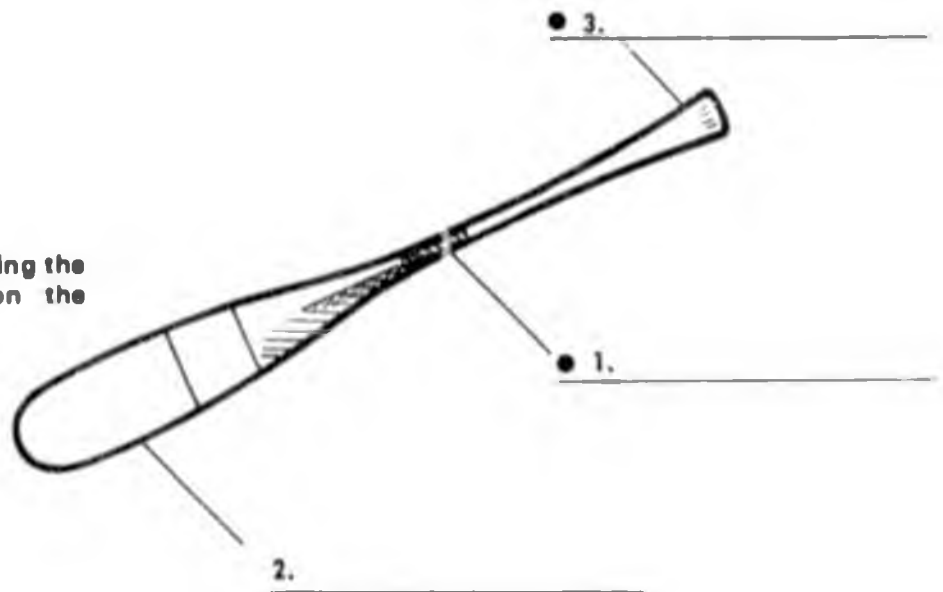

RIVER RUNNING FUN

Know your put-in point and your take-out point before you begin

1. Travel in a least groups of three boats while on the river. Keep the boat behind you in sight.

DANGER!
If the river disappears, you may be approaching a waterfall

3. Capsized? Stay at the upstream end of the canoe. Your life is more important to save than equipment. If carried by the current, keep your toes up and your feet together. Never try to stand up unless the water is too shallow to swim. If a heaving line is tossed the rescuer should belay it (to a tree or boulder).

5. When you approach obstructions, set your course well in advance. Know how to approach. If in doubt, scout from shore.

----- High water course
 Normal level course



2. Things to avoid: flow through hazards, waterfalls, low dams, high rapids and hydraulics. Even in slow water these can be very dangerous.



HYDRAULIC
Water circulates back and forces a canoe downward

4. When striking an obstruction sideways, lean the canoe downstream, but don't get caught between the canoe and the obstruction. With the upstream gunwale up, the canoe will be easier to remove from the rock.

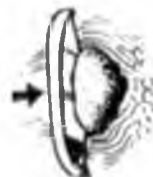

Upstream gunwale up



Downstream gunwale up

6. Remember, the river current is usually faster on the outside of a bend. It also spirals (folds under) down to the bottom.

7. Upstream V's indicate rocks. Downstream V's with haystacks indicate gaps between rocks.

8. When leaving, secure all equipment and carry trash out with you.

If you are not prepared to swim it; don't canoe it!

Take a Red Cross sponsored canoeing course

Information courtesy American Red Cross

RIVER RUNNING FUN

River Running

River float trips in canoes, kayaks and rafts are becoming more and more popular throughout the entire nation.

The float trip season generally lasts from May to September or longer where a warmer climate permits. Mid-summer, after the spring run-off has filled rivers and streams, is the time when most trips occur. Temperatures ranging from 60-90 degrees F (16-32 degrees C) in the daytime and 40-70 degrees F (4-21 degrees C) at night are suitable for float trips.

The adventurous may float in an assortment of scenery, from meandering rivers through flatland forests to cascading mountain streams. Distances range from day trips less than 10 miles to voyages lasting weeks over hundreds of miles. A field of additional sports are available for the floating enthusiast including fishing, camping, swimming and hiking.

But whatever the schedule and wherever the trip takes place, the floater will find fascinating geological formations, an abundance of wildlife, historical sights and perhaps lots of cold spray.

Basic safety rules are as important for enjoyable river running as for powerboating or sailing. Use the following points as a guide for your next, or first float trip.

1. Wear an approved P.F.D. Be sure each passenger has his/her own P.F.D. of correct size.
2. Don't overload the boat with either passengers or gear.
3. Check out your equipment before starting out. An inflatable raft with several air chambers will tend to remain afloat longer if a chamber is punctured.
4. Be familiar enough with the route to plan for proper paddles and/or motors. Pack appropriate camping gear, first aid supplies, warm, easily



dried clothing, insect repellent, fishing gear and license, food, tarps and camera. Do not forget to waterproof your personal gear.

5. Be sure of your skills by starting with an easy run. If possible go with experienced river runners to learn the basic strokes and movements of the craft through various types of water.
6. Do not float alone. Three boats is the usual minimum for a white water run.
7. Fasten down all ropes so that there is no danger of becoming entangled in case you overturn.
8. Beach your vessel overnight a safe distance from the river's edge and tie it securely to a tree or large rock in case of flash flooding, etc. Then carry it back to the water, do not drag it.
9. Stop, get out of your boat, and look over from shore all rapids and other danger spots. If in doubt, carry your boat around the difficulty.
10. Beware of overhanging trees, log jams, brush piles and other obstacles that the water flows through rather than around. You can be pinned against them, possibly under the water, by the force of the current. Pass them on the safety side. Do not grab limbs or debris to control the boat's direction. That's a quick way to swamp!
11. Do not try to run dams. You can be trapped in the recirculating current at the bottom.
12. If you overturn, stay on the upstream side of your boat so that you will not be crushed between it and a rock. In most cases stay with the boat since it won't sink.
13. But cold water can be paralyzing on both mind and body. Get out of it quickly. Do not lose your life trying to save your boat.
14. Stay alert to changing weather conditions while on the water. Get out onto shore before a storm hits.



SAILBOATS

Sailboat Parts

Sailboats have four basic parts: a *hull*, *sail(s)*, *centerboard* (or *keel*) and *rudder*.

Hulls are designed to float a load and move through the water easily. They also help balance the boat when wind applies pressure to the sail.

Larger boats have heavy *ballast* or weight packed into the bottom of the boat to prevent tipping. Smaller boats rely on the weight of passengers.

Sails convert wind pressure into movement of the hull. This is done through design, material, craftsmanship, and proper operation and maintenance. Most sails on recreational and competitive boats are made of synthetic material. Because synthetic fibers are damaged by sunlight, sailors must remove the sail or cover it when not in use.

Small sails may be folded after they are dry. They should not be wrinkled. This prevents air from flowing smoothly over the sail's surface.

All sailboats have a stabilizer called a *centerboard* or *keel*. This helps prevent tipping over or capsizing. It also keeps the boat from sliding sideways (*leeway*) when going across the wind.

Small sailboats use a centerboard. It may be raised or lowered into the water as needed.

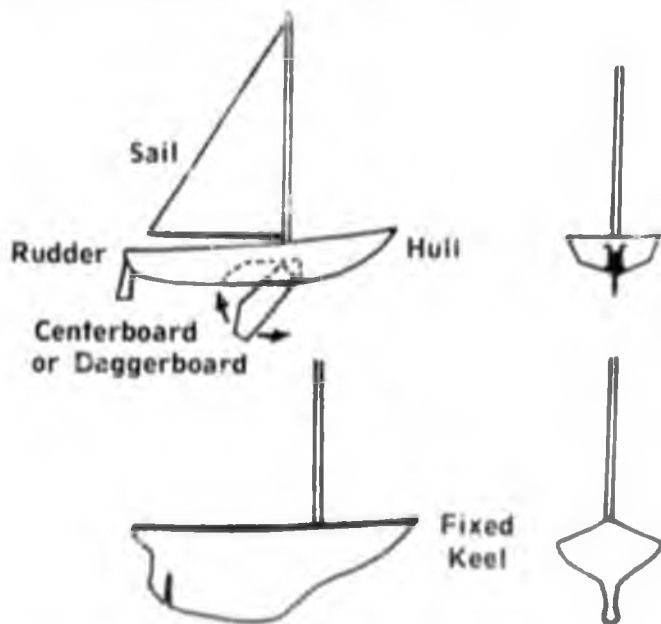

Larger sailboats use a fixed keel. The keel is part of the hull. It carries additional weight, usually lead or cement. The weight of the keel offsets pull from the sail. Centerboards and keels also help turn a sailboat.

The rudder is located at the stern (back) of a boat. It is used to steer the sailboat. Small sailboats have wooden or metal bars called *tillers* fastened to the top

of the rudder. A tiller is the same as a steering wheel on a motorboat. When the tiller is moved to one side, the rudder moves the boat to the opposite side. A sailboat must be moving for the rudder to work.

Why A Sailboat Sails

Two principles are at work when a boat sails. A boat sailing downwind or running is being pushed by wind. A boat sailing against the wind or beating is being pulled by wind. A boat sailing with the wind *abeam* [reaching] is using both principles. Reaching is the fastest and easiest way to sail.

When sailing there is a gradual change from one principle to the other. Therefore, sailors must have a constant awareness of wind and its direction. Developing this feeling is essential and difficult for a beginner to master. *Starboard tack* means the wind is passing over the right side of the boat. *Port tack* means the wind is passing over the left side of the boat.

Looking at the illustrations at the bottom of the next page it is easy to see the way sailboats move closer or further away from the direction of the wind. Manuevers closer to the direction of the wind start with a *beat*. When beating as near as possible into the wind at about 45 degrees, the boat is *close-hauled*.

As a boat sails away from the wind it moves on a *close reach* and then a *reach* when *abeam* to the wind. As it moves further from the wind it enters a *broad reach* and then a *run*. For the last two manuevers the wind is almost directly behind the boat.

To turn a sailboat's bow through the direction of the wind is called a *come about*. An example of this is changing *tack* from one reach to another by *rolling* the bow through the wind.

Turning the boat from one broad reach to the other by moving the stern through the wind is termed *jibing*. The boom on the mainsail must be hauled in when a boat jibes. A wildly swinging boom can knock someone from the deck or tip the boat over. This type of knockdown is called an uncontrolled jibe.

Boats can also change tack from a broad reach by coming about with the bow into the wind. This method takes longer, but it is safer for an inexperienced sailor.

A constant hazard to the sailboater is a knockdown. It is most likely to happen when sailing on a reach at right angles to the wind, especially if the boat is moving slowly. A strong gust of wind can blast the sails over and onto the water if an unwary skipper has the main sheet and jib cleated tightly.

SAILBOATS

Sailboat Equipment

Required equipment on a sailboat depends on the laws applicable in your area. Federal requirements are outlined on page 40, but each state may have additional requirements. Equipment also varies according to the boat's classification.

Sailors may decide to carry more than the minimum required equipment. They should judge local wind and water conditions and their skills.

The following equipment is recommended. It may also be required in your area. Check local laws.

1. **Personal Flotation Device** for each person on board. Weak swimmers and non-swimmers should wear one at all times.
2. **Bailer.** Water in the bilge decreases stability. Use a sponge, can or pump.
3. **Lights.** (See page 35.) Also check local laws.
4. **Paddles or Oars** to use when sails are lowered or during periods of calm. Sailboats with auxiliary power should also carry one of these.
5. **Anchor** to keep from being drifted away by currents, tides or high winds.
6. **Extra Line** in addition to a bow line permanently attached to the craft.
7. **Boathook** to use when pushing off during a landing. Also to pick up mooring lines.

Rules of the Road

Sailors must know the rules of the road in their areas. The rules outline procedures for meeting other boats to prevent collisions. (Also see pages 59-62). Under these rules sailboats have the right of way

over motorboats unless they are the overtaking vessel, then they must keep out of the way of the other vessel. Canoes, rowboats and other "people-powered" vessels have the right of way over sailboats. Boats operating with sail and power are classified as motorboats.

When two sailboats meet, the *give-way* [burdened] vessel must stay clear of the *stand-on* [privileged] vessel. The following situations apply under Inland rules of the road.

1. A sailboat running free, (with wind dead astern), must keep clear of one close hauled, (sailing close to the wind, on a beat).
2. A sailboat close hauled on the port tack, (with wind coming over the port bow or beam), must keep clear of one close hauled on the starboard tack, (with wind coming over the starboard bow or beam).
3. When both boats are running free on opposite tacks, the vessel with the wind on the port side must keep clear.
4. If both boats are running free on the same tack, the boat to *windward* must keep clear.

Under International Rules, a boat on the starboard tack always has the right of way. If both boats are on the same tack, the one to *leeward* [downwind] has the right of way. If a sailboat with the wind on the port side sees a sailboat to the windward and does not know whether it has the wind on the port side or on the starboard side, it must keep out of the way.

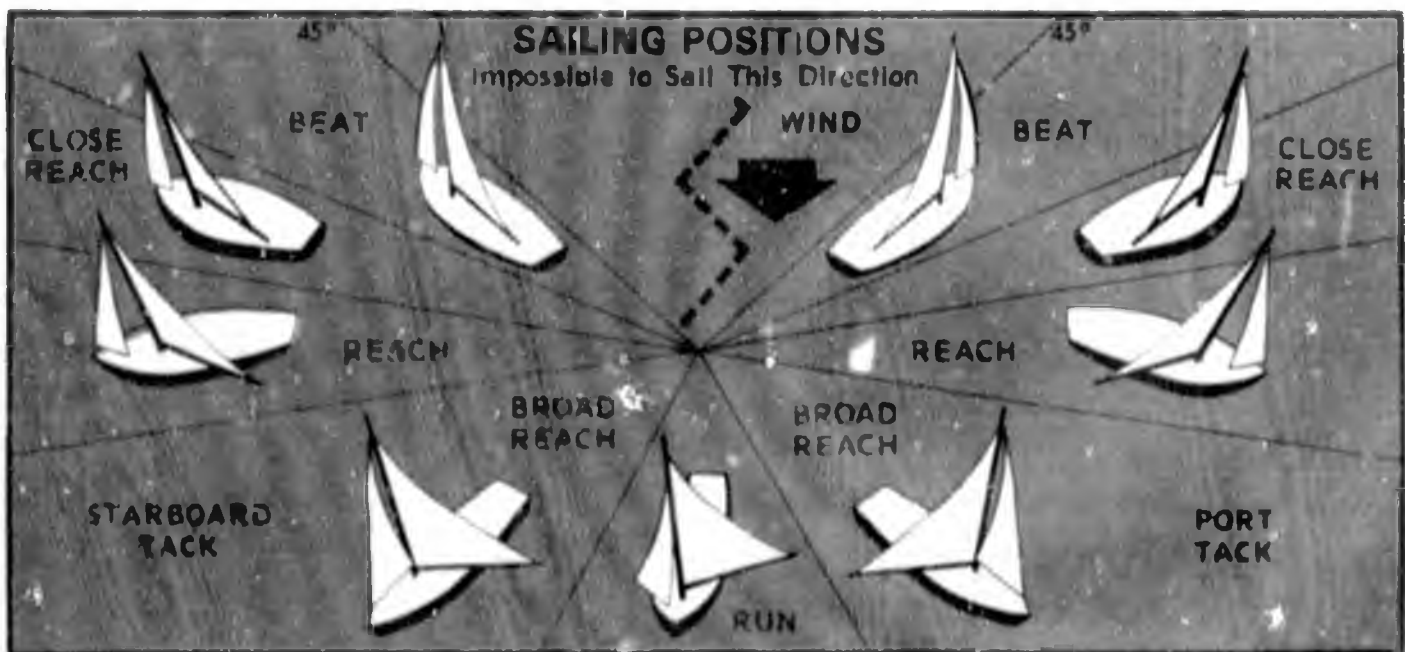

SAILOR'S LANGUAGE

Label the parts of the sailboat by matching the numbers on the list with those on the diagram.

1. Weather vane
2. Batten
3. Mainsail
4. Leech
5. Shroud
6. Foot
7. Boom
8. Block
9. Main Sheet
10. Tiller
11. Rudder
12. Daggerboard
13. Jib Sheet
14. Gooseneck
15. Jib
16. Luff
17. Mast
18. Headboard
19. Figure "8" Knot

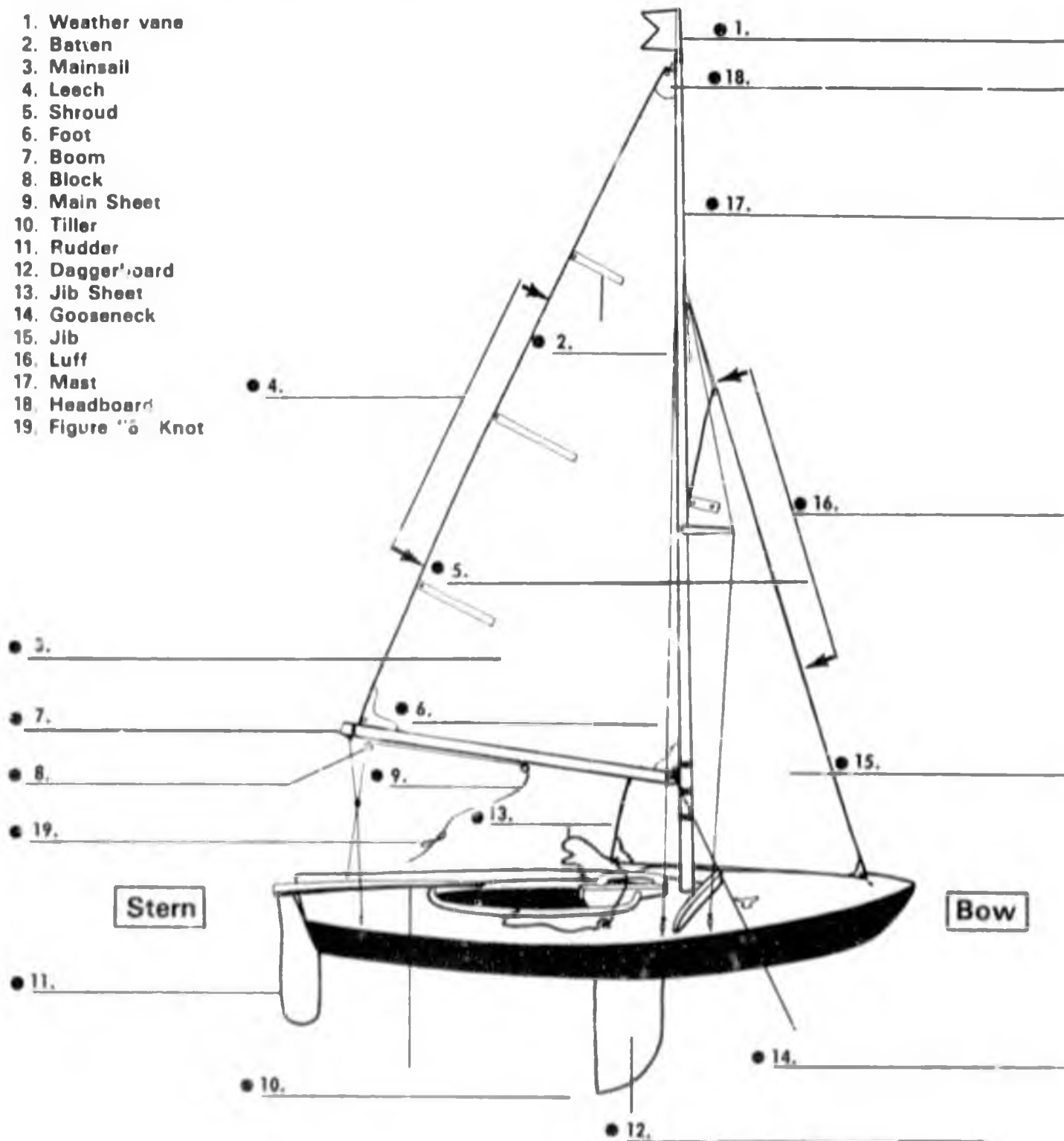

BOAT HULLS

Planing Hull

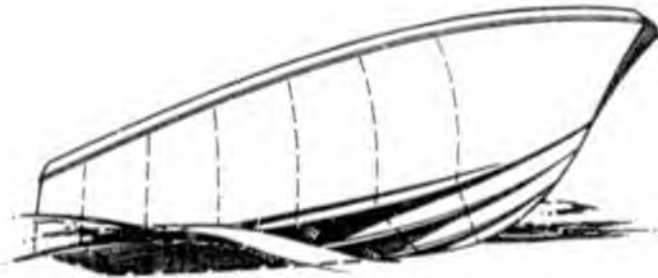

Displacement Hull

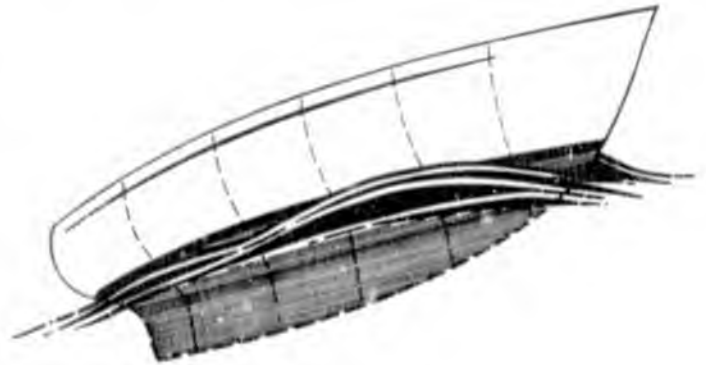

Basic Boat Hulls

Boat hulls are either displacement or planing. These two types include all the boats that have ever been built. A *planing* hull slides across the water at high speed. More power makes it go even faster. A *displacement* hull ploughs through the water even when more power is added.

How a boat is to be used, and generally the speed at which it is to operate, decides whether it should be a displacement or planing type hull.

Six common hull designs that include planing and displacement hulls are:

1. Flat bottom
2. Round bottom
3. V-bottom
4. Deep V
5. Cathedral
6. Catamaran

Flat bottom square-sided boats include hoxy, home-made utility boats, racing runabouts and deluxe 40 foot houseboats. Flat bottoms plane easily.

Round bottom boats move easily at slow speeds. They have a great tendency to roll unless they have a large flat area near the stern. Canoes, tugboats and

some fishing boats have round bottoms and displacement hulls.

The V-bottom is an improvement over the flat bottom because it is more stable and rides better in rough water. It can be either a planing or displacement hull depending on the design.

The Deep-V is a hull with a sharp or deep V bottom that has been promoted extensively in recent years. It planes well with a stern-drive and offers a very comfortable ride in rough water.

Cathedral hulls are a combination of deep-V and catamaran. See the illustration below. The twin "tunnels" along each side of the main hull trap spray and water to cushion the ride as well as to hold down spray when planing through waves. The cathedral hull design is popular on many fiberglass lines of boats.

Catamaran hulls were probably first used for stability. Any kind of float or raft supported on two pointed logs uses the basic catamaran design. The twin-hulled design can be either planing or displacement, depending on the shape of the two hulls used. In sailboats the twin hulls are normally displacement, but in power boats they are usually planing type bottoms.

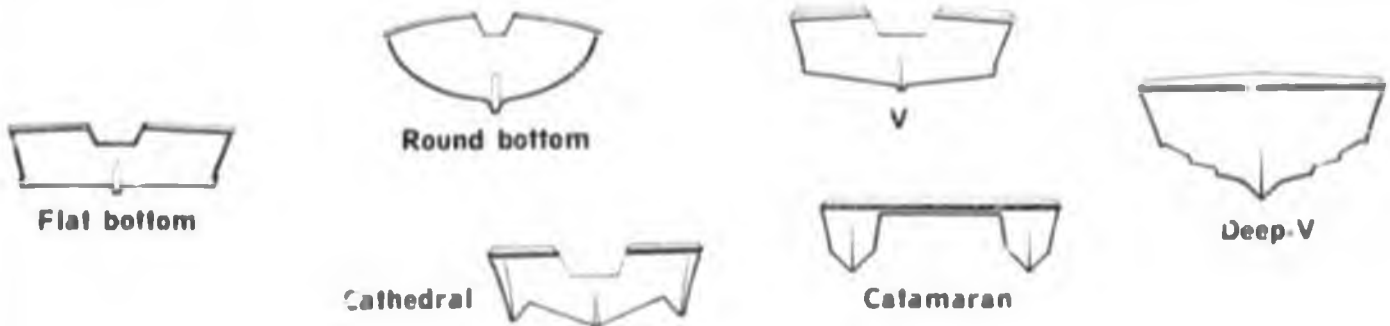

REGISTRATION and NUMBERING

Registration

The Federal Boating Safety Act of 1971 requires all undocumented vessels equipped with machine propulsion to be numbered in its state of principal use. This number will be issued by the state where the boat is principally used on a registration form much the same as that for an automobile. If the state does not have an approved numbering system, which Alaska does not, then the Coast Guard will issue the number.

There are certain exceptions to the rule:

1. Boats propelled manually.
2. Certain public vessels (enforcement and rescue).
3. Vessels documented by the United States Coast Guard.
4. Foreign vessels.
5. Ship's lifeboats used solely for lifesaving purposes.
6. Vessels having valid registration in the state of its principal use and not remaining in Alaska over 90 days.
7. Vessels used exclusively for racing.

Registration forms may be obtained from any post office, marina, U.S. Coast Guard Boating Safety Team (P.O. Box 2471, Anchorage, AK 99510) or Boating Safety Office (P.O. Box 3-5000, Juneau, AK 99802).

How to Register

Applications to register must be sent to the Boating Safety Office in Juneau. Upon receipt of the required information and the \$6.00 fee, the requester will receive a Certificate of Numbers, a set of Registration stickers and information on how to properly apply them to your hull. The boat registration number is the number (beginning with AK) shown in the certificates.

Certificate of Number

The Certificate of Number must be available for inspection on the vessel whenever it is being used on the water. Proper display of the current registration stickers on the vessel next to the AK number is required to permit enforcement officers to determine, without boarding, that the vessel is currently registered.

In addition, personal ID may be required by law enforcement officers.

CERTIFICATE OF NUMBER							
THIS CERTIFICATE HAS BEEN ISSUED IN ACCORDANCE WITH THE FEDERAL BOAT SAFETY ACT OF 1971 AND COAST GUARD REGULATIONS							
REGISTRATION NUMBER AK 0001-N				EXPIRATION DATE 20 August 1981			
DOE, RICHARD P.O. Box Sitka,				Mary Jane			
Homemade	24'	'76	wood	I/O	Gas	Pls.	Cru.
MAKE OF BOAT	LGTH	YR BLT	HULL	PROP	FUEL	USE	TYPE
HULL IDENTIFICATION NUMBER ABC 56789M 73E				STATE OF PRINCIPAL USE ALASKA			

The Certificate of Number also has several other purposes:

1. Helps the owner identify the boat if stolen.
2. Provides way to identify boat being driven recklessly.
3. Allows a person to operate the boat in other states without other numbering.
4. Helps identify the owner of a boat that has caused damage, been lost or drifted away.
5. Makes it possible to enforce water laws.
6. Encourages boat operators to use boats carefully because they can be identified by their boat number.

Registration Fees

Original Registration	\$6.00
Transfer of Ownership	\$6.00
Duplicate Certificate	\$1.00
Duplicate Stickers	\$.25
Renewal of Number (tri-annually)	\$6.00

Display of Numbers and Stickers

The number must be displayed properly on the boat. The law requires:

1. The numbers are to be read from left to right.
2. They must be displayed on the forward half of each side of the bow of the boat.

REGISTRATION and NUMBERING

3. Numbers must be in bold, block letters of good proportion.
4. They must not be less than three inches high.
5. They must be of contrasting color to the boat hull or background.
6. They must be as high above the waterline as practical.
7. No number other than the number assigned can be displayed on the forward half of the vessel.
8. Letters must be separated from numbers by spaces or hyphens.
9. Validation decals must be displayed within six inches of the number.

AK-0001-N
OR
AK 0001 N

Notification Requirements

The owner is required to notify the Coast Guard Boating Safety Office in Juneau in writing when ever any of the following takes place:

1. The vessel has been destroyed or abandoned. Notice must be given within 15 days and be accompanied by the Certificate of Number and Certificate of Ownership.
2. The owner's address has been changed. Notice must be given within 30 days.
3. Stolen boat. If a numbered vessel is stolen, the owner or legal owner of the vessel should notify the Coast Guard Boating Safety Office, as well as the enforcement authorities, as soon as possible.
4. The owner shall also notify the Coast Guard if a vessel reported to be stolen is recovered.

How to Display Numbers Correctly

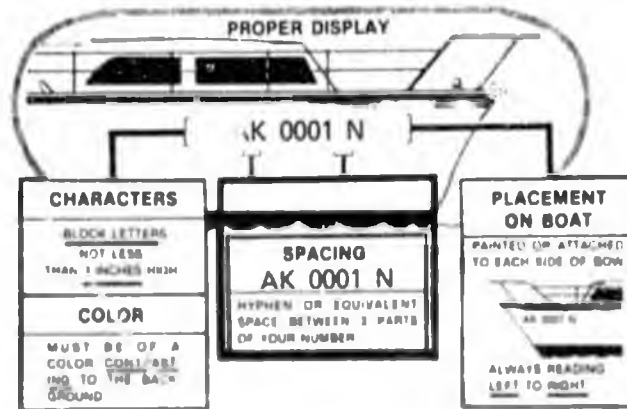

Identification Code

Find your code and circle:

* Alaska	AK	Illinois	IL	Nebraska	NB	South Carolina	SC
Alabama	AL	Indiana	IN	Nevada	NV	South Dakota	SD
Arizona	AZ	Iowa	IA	* New Hampshire	NH	Tennessee	TN
Arkansas	AR	Kansas	KA	New Jersey	NJ	Texas	TX
California	CF	Kentucky	KY	New Mexico	NM	Utah	UT
Colorado	CL	Louisiana	LA	New York	NY	Vermont	VT
Connecticut	CT	Maine	ME	North Carolina	NC	Virginia	VA
Delaware	DL	Maryland	MD	North Dakota	ND	* Virgin Islands	VI
* Dist. of Columbia	DC	Massachusetts	MS	Ohio	OH	* Washington	WN
Florida	FL	Michigan	MC	Oklahoma	OK	West Virginia	WV
Georgia	GA	Minnesota	MN	Oregon	OR	Wisconsin	WS
* Guam	GM	Mississippi	MI	Pennsylvania	PA	Wyoming	WY
Hawaii	HA	Missouri	MO	* Puerto Rico	PR		
Idaho	ID	Montana	MT	Rhode Island	RI		

♦ Application for Certificate of Number available at local Coast Guard station.

CCGDI7-145 (3-77)		APPLICATION FOR BOAT NUMBER			AK-	
1. NAME OF OWNER (FIRST MIDDLE LAST NAME)				2. DATE OF BIRTH	3. CITIZENSHIP	
4. MAILING ADDRESS (include city, state, zip code)						
5. MFG. HULL ID NUMBER (IF ANY)		6. PRESENT BOW NUMBER (IF ANY)		7. MFG OF ENGINE		
8. MFG OF BOAT			9. LENGTH IN FEET		10. YEAR BUILT	
11. HULL MATERIAL	12. PROPULSION	13. FUEL	14. USE		15. TYPE OF VESSEL	
<input type="checkbox"/> Plastic or Fiberglass	<input type="checkbox"/> Outboard	<input type="checkbox"/> Gasoline	<input type="checkbox"/> Pleasure	<input type="checkbox"/> Commercial	<input type="checkbox"/> Runabout	
<input type="checkbox"/> Aluminum	<input type="checkbox"/> Inboard	<input type="checkbox"/> Diesel	<input type="checkbox"/> Livery	<input type="checkbox"/> Passenger	<input type="checkbox"/> Cruiser	
<input type="checkbox"/> Wood	<input type="checkbox"/> Inboard Outdrive	<input type="checkbox"/> Other	<input type="checkbox"/> Dealer	<input type="checkbox"/> Commercial	<input type="checkbox"/> House	
<input type="checkbox"/> Steel	<input type="checkbox"/> Sail Only	(Specify)	<input type="checkbox"/> Manufacturer	<input type="checkbox"/> Fishing	<input type="checkbox"/> Sailing	
<input type="checkbox"/> Other (Specify)	<input type="checkbox"/> Other (Specify)		<input type="checkbox"/> Other (Specify)		<input type="checkbox"/> Other (Specify)	
16. REASON FOR APPLICATION				MAIL TO: BOATING SAFETY DIVISION		
<input type="checkbox"/> ORIGINAL NUMBER		<input type="checkbox"/> RENEWAL OF NUMBER		U. S. COAST GUARD		
<input type="checkbox"/> TRANSFER OF OWNERSHIP		<input type="checkbox"/> CHANGE OF STATE OF PRINCIPAL USE		P. O. BOX 3-5000		
			JUNEAU, ALASKA 99802			
SIGNATURE:			I DECLARE under the penalties prescribed in 18 USC 1001, to the best of my knowledge and belief that I own the vessel described herein and that the description and all matters stated herein are true and correct.			
<p>PRIVACY ACT STATEMENT</p> <p>In accordance with 5 USC 552a(e), the following information is provided to you when supplying personal information to the U. S. Coast Guard.</p> <p>1. AUTHORITY which authorized the solicitation of the information The Federal Boat Safety Act of 1971, 46 USC 1451, 1456, 1467</p> <p>2. PRINCIPAL PURPOSE(S) For which information is intended to be used: Principally used when boat owners are applying registration of undocumented vessel, equipped with propulsion machinery of any type and to have numbers issued by the proper issuing authority in the state in which the vessel is principally used.</p> <p>3. THE ROUTINE USES which may be made of the information: (1) For statistical purposes showing alphabetically and numerically the boats have registered. (2) For public inquiry from other states, credit unions, individuals concerned with the purchase of a vessel from someone else. (3) For office to transfer or renew boat registration.</p> <p>4. Whether or not DISCLOSURE of such information is mandatory or voluntary (Required by law or optional) and the effects on the individual, if any, of not providing all or any part of the requested information: Disclosure of this information is voluntary, but failure to furnish required information would result in non-issuance of a valid certificate of number.</p>			<p>INSTRUCTIONS (Print or Type)</p> <p>Complete all numbered items. Numbers 2,3,8 and 11-15 are self-explanatory. Special instructions for specific items are as follows:</p> <p>1 & 4: Name and address of owner only. List additional owners in the space provided below these instructions.</p> <p>5: Hull Identification Number (assigned by manufacturer). If the boat has a number permanently on the hull, list it here.</p> <p>7: Manufacturer of engine. Insert name of company that built the engine. If built by the owner or builder is unknown, so state.</p> <p>8: Manufacturer of Boat. Insert name of company that built the boat. If built by owner or builder is unknown, so state.</p> <p>9: Length in Feet. Insert length of vessel (to nearest inch) measured from end to end and over the deck, excluding the sheer.</p> <p>10: Year Built. Insert year built (or model year), if known. If the year is unknown, so state.</p> <p>16: Reason for Application. Insert 'X' in appropriate box. If application is for a new number as a result of lien holder possession, attach a signed statement explaining the possession in detail. If the Application is for Transfer of Ownership, the reverse of this form must be filled out by the seller and forwarded with this application.</p> <p>IMPORTANT</p> <p>Names of additional Owners</p> <hr/> <hr/> <p>Mail Application and check or money order for \$6.00 dollars to: BOATING SAFETY DIVISION U. S. COAST GUARD P. O. BOX 3-5000 JUNEAU, ALASKA 99802</p>			

BOAT NUMBER	NOTIFICATION OF CHANGE IN STATUS OF VESSEL	APPLICATION FOR DUPLICATE CERTIFICATE OF NUMBER
NAME OF OWNER ON CERTIFICATE OF NUMBER		HULL IDENTIFICATION NUMBER (if Any)
MAILING ADDRESS		
CITY, STATE, and ZIP CODE		
Check appropriate block and attach Certificate of Number. If Certificate of Number is lost, explain circumstances below.		
<input type="checkbox"/> VESSEL DOCUMENTED	<input type="checkbox"/> VESSEL ABANDONED	<input type="checkbox"/> CERTIFICATE LOST (Explain)
<input type="checkbox"/> VESSEL DESTROYED	<input type="checkbox"/> VESSEL RECOVERED	<input type="checkbox"/> CERTIFICATE DESTROYED
<input type="checkbox"/> VESSEL STOLEN	<input type="checkbox"/> OWNER CHANGE OF ADDRESS	
<input type="checkbox"/> TRANSFER OF OWNERSHIP (New owners Name _____)		
NOTE: Federal Law requires whenever a vessel casualty or accident results in death, injury or property damage, a report must be filed by those involved.		MAIL TO: BOATING SAFETY DIVISION U. S. COAST GUARD P. O. BOX 3-5000 JUNEAU, ALASKA 99802
DATE	SIGNATURE OF PAST OWNER	
FEEs ORIGINAL NUMBER \$6.00 RENEWAL OF NUMBER \$6.00 TRANSFER OF OWNERSHIP \$6.00 DUPLICATE OF CERTIFICATE \$1.00		
INSTRUCTIONS (Print or Type) NOTIFICATION OF CHANGE IN STATUS OF VESSEL 1. Complete all items 2. Name and address of present owner. One name only. 3. Attach Certificate of Number. NOTE: The owner listed on the certificate of number shall remove the number and validation stickers from the vessel when: (a) The vessel is Documented by the Coast Guard (b) The certificate becomes invalid; or (c) There is a change in state of principal use.		INSTRUCTIONS (Print or Type) APPLICATION FOR DUPLICATE CERTIFICATE OF NUMBER 1. Complete all items. 2. Name and address of present owner. One name only. 3. Mail Application and CHECK or MONEY ORDER to: BOATING SAFETY DIVISION U. S. COAST GUARD P. O. BOX 3-5000 JUNEAU, ALASKA 99802

Back

424 529

RESPONSIBILITY

Your Responsibility As a Boater

You may be held responsible for any damage your boat may cause or any injuries suffered by your passengers or others. For instance, if you pass close to a cruiser at high speed and your wake rocks this vessel so that the dishes in the galley are broken, you may be held responsible. If this should happen when hot foods are being prepared or served on board the cruiser and someone suffers serious burns as a result of the violent rocking caused by your wake, you may be held liable. You could be summoned into court and equitable civil damages assessed against you. In addition, you might also be cited for operating a motorboat in a negligent manner.



Overloading

Negligent and Grossly Negligent Operation

Negligent operation is the failure to exercise that degree of care necessary under the circumstances to prevent the endangering of life, limb or property of any person. Negligent operation may be caused by the

operator's ignorance, inattention, indifference or general carelessness.

Grossly negligent operation implies extreme forms of negligence. Gross negligence is an absence of all care. The term means that the operator of a boat knows that a certain act can create an unreasonable risk of harm, even though he does not necessarily intend to cause harm.

Examples of such operation include but are not limited to:

1. Excessive speed in close proximity to other boats in narrow winding channels or rivers.
2. Excessive speed during periods of reduced visibility.
3. Operating under the influence of intoxicants, drugs, etc., recognizable by erratic operation.
4. Failure to properly moor a vessel which becomes loose and causes damage to another vessel, property or person.

Regarding Speed

Excessive speed can create a dangerous wake causing other boats in the vicinity to slip water, loose equipment or in other ways receive damage. This wake can also threaten the safety of persons in nearby boats. This kind of operation can endanger life, limb and/or property.



Riding on Decks and Gunwales



Speeding

RESPONSIBILITY

Accidents

Boating Accident Reports are used by the U.S. Coast Guard to identify problem areas and major causes of boating mishaps. The reports are confidential and cannot be used in legal matters.

The operator of a vessel involved in an accident shall:

1. Give assistance to other persons involved.
2. Give his name, address, and identification of his boat in writing to any person injured or to the owner of any property damaged in the accident.
3. When a person dies or disappears from a vessel, the operator shall, without delay, by the quickest means available, notify the U.S. Coast Guard Boating Safety office and the nearest enforcement agency having jurisdiction over the waterbody.
4. If there is death or injury to a person, or if there is damage to property of more than \$100, the operator shall submit a written report of the accident to the U.S. Coast Guard.

This report shall be made within five days after the accident. In the case of an injury, it must be submitted within 48 hours. Accidents involving death or disappearance must be reported within 24 hours.

Forms are available through harbormaster offices and may also be obtained by writing to the Coast Guard Boating Safety Division, P.O. Box 3-5000, Juneau, AK 99802.

Failure to comply with the above requirements is punishable by a fine up to \$500.



Voicing A Complaint

In the case of harrassment or operating negligence by some other party, you have the right and the responsibility to make a complete and accurate report to one of several agencies: city police, Department of Public Safety, harbormaster, State Department of Fish & Game, state troopers and the U.S. Coast Guard.

When reporting, include date, time, description of boat (color, hull design and classification) boat registration numbers, witnesses (names and addresses) and photographs if possible.



RESPONSIBILITY

DEPARTMENT OF TRANSPORTATION U. S. COAST CG-3865 (Rev. 5-75)	BOATING ACCIDENT REPORT	FORM APPROVED OMB No. 04-R3012			
The operator of every vessel involved is required to file a report in writing whenever a boating accident results in loss of life; loss of consciousness; medical treatment or disability in excess of 24 hours or property damage in excess of \$100. Reports in death and injury cases must be submitted within 48 hours, reports in other cases are required within 5 days. All reports must be submitted (a) to the state where the vessel number is issued (b) if the vessel has no number, where the vessel is principally used (c) the state where the casualty or accident occurred, if it occurred outside the state where the vessel is numbered or the place where the accident occurred. See addresses on reverse.					
COMPLETE ALL BLOCKS (Indicate those not applicable by "N/A")					
NAME AND ADDRESS OF OPERATOR OPERATOR TELEPHONE NO.	AGE OWNER TELE. NO.	OPERATOR'S EXPERIENCE THIS TYPE OF BOAT <input type="checkbox"/> UNDER 20 HOURS <input type="checkbox"/> 20 TO 100 HOURS <input type="checkbox"/> 100 TO 400 HOURS <input type="checkbox"/> OVER 400 HOURS OTHER BOAT OPERATING EXP. <input type="checkbox"/> UNDER 20 HOURS <input type="checkbox"/> 20 TO 100 HOURS <input type="checkbox"/> 100 TO 500 HOURS <input type="checkbox"/> OVER 500 HOURS			
NAME AND ADDRESS OF OWNER	RENTED BOAT <input type="checkbox"/> YES <input type="checkbox"/> NO	NO. OF PERSONS ON BOARD POWERED INSTRUCTIONS IN BOATING SAFETY <input type="checkbox"/> NONE <input type="checkbox"/> USCG AUXILIARY <input type="checkbox"/> U.S. POWER SQUADRON <input type="checkbox"/> AMERICAN RED CROSS <input type="checkbox"/> STATE <input type="checkbox"/> OTHER (Indicate)			
VESSEL NO. 1					
BOAT NUMBER	BOAT NAME	BOAT MAKE	BOAT MODEL	MPR HULL IDENTIFICATION NO.	
TYPE OF BOAT <input type="checkbox"/> OPEN MOTORBOAT <input type="checkbox"/> CABIN MOTORBOAT <input type="checkbox"/> AUXILIARY SAIL <input type="checkbox"/> SAIL (ONLY) <input type="checkbox"/> ROWBOAT <input type="checkbox"/> OTHER (Specify)	HULL MATERIAL <input type="checkbox"/> WOOD <input type="checkbox"/> ALUMINUM <input type="checkbox"/> STEEL <input type="checkbox"/> FIBERGLASS (Fibreg) <input type="checkbox"/> OTHER (Specify)	ENGINE <input type="checkbox"/> OUTBOARD <input type="checkbox"/> INBOARD GASOLINE <input type="checkbox"/> INBOARD DIESEL <input type="checkbox"/> INBOARD-OUTDRIVE <input type="checkbox"/> OTHER (Specify)	BOAT DATA (Propulsion) NO. OF ENGINES MAKE OF ENGINE HORSEPOWER (Total) YEAR BUILT (Engine) TYPE OF FUEL	BOAT DATA (Construction) LENGTH BIRTH BEAM DEPTH (Inner Transom To Keel) YEAR BUILT (Hull)	
ACCIDENT DATA					
DATE OF ACCIDENT	TIME AM PM	NAME OF BODY OF WATER	LOCATION (Give location precisely)		
STATE	NEAREST CITY OR TOWN		COUNTY		
WEATHER <input type="checkbox"/> CLEAR <input type="checkbox"/> CLOUDY <input type="checkbox"/> FOG <input type="checkbox"/> RAIN <input type="checkbox"/> SNOW <input type="checkbox"/> HAZE	WATER CONDITIONS <input type="checkbox"/> CALM <input type="checkbox"/> CHOPPY <input type="checkbox"/> ROUGH <input type="checkbox"/> VERY ROUGH <input type="checkbox"/> STRONG CURRENT	TEMPERATURES (Indicate) AIR _____ °F WATER _____ °F	WIND <input type="checkbox"/> NONE <input type="checkbox"/> LIGHT (0-5 MPH) <input type="checkbox"/> MODERATE (7-14 MPH) <input type="checkbox"/> STRONG (15-25 MPH) <input type="checkbox"/> STORM (Over 25 MPH)	VISIBILITY <input type="checkbox"/> GOOD <input type="checkbox"/> FAIR <input type="checkbox"/> POOR	WEATHER ENCOUNTERED <input type="checkbox"/> WAS AS FORECAST <input type="checkbox"/> NOT AS FORECAST <input type="checkbox"/> NO FORECAST OBTAINED
OPERATION AT TIME OF ACCIDENT (Check all applicable) <input type="checkbox"/> CRUISING <input type="checkbox"/> APPROACHING DOCK <input type="checkbox"/> WATER SKIING <input type="checkbox"/> RACING <input type="checkbox"/> FISHING <input type="checkbox"/> BEING TOWED <input type="checkbox"/> DRIFTING <input type="checkbox"/> AT ANCHOR <input type="checkbox"/> TIED TO DOCK <input type="checkbox"/> FUELING <input type="checkbox"/> FISHING <input type="checkbox"/> BEING DIVING OR SWIMMING <input type="checkbox"/> OTHER (Specify)	TYPE OF ACCIDENT <input type="checkbox"/> BRUISING <input type="checkbox"/> LAMINATING <input type="checkbox"/> FLOODING <input type="checkbox"/> SINKING <input type="checkbox"/> FIRE OR EXPLOSION (Pool) <input type="checkbox"/> FIRE OR EXPLOSION (Other than fuel) <input type="checkbox"/> COLLISION WITH VESSEL	<input type="checkbox"/> COLLISION WITH FIXED OBJECT <input type="checkbox"/> COLLISION WITH FLOATING OBJECT <input type="checkbox"/> FALLS OVERBOARD <input type="checkbox"/> FALLS IN BOAT <input type="checkbox"/> BURNS <input type="checkbox"/> HIT BY BOAT OR OBJECT <input type="checkbox"/> OTHER (Specify)	WHAT IN YOUR OPINION CAUSED THE ACCIDENT? <input type="checkbox"/> WEATHER CONDITIONS <input type="checkbox"/> EXCESSIVE SPEED <input type="checkbox"/> NO PROPER LOOKOUT <input type="checkbox"/> OVERLOADING <input type="checkbox"/> IMPROPER LOADING <input type="checkbox"/> HAZARDOUS WATERS <input type="checkbox"/> OBSTACLES TO VISION <input type="checkbox"/> FAULT OF HULL <input type="checkbox"/> FAULT OF MACHINERY <input type="checkbox"/> FAULT OF EQUIPMENT <input type="checkbox"/> OTHER (Specify)		
PERSONAL PREPARATION DEVICES			SAFETY EQUIPMENT		
WERE THE BOAT ADEQUATELY EQUIPPED WITH US APPROVED LIFESAVING DEVICES? <input type="checkbox"/> YES <input type="checkbox"/> NO WERE THEY ACCESSIBLE? <input type="checkbox"/> YES <input type="checkbox"/> NO WERE THEY USED? <input type="checkbox"/> YES <input type="checkbox"/> NO	WERE THE VESSEL CARRYING NON-APPROVED LIFESAVING DEVICES? <input type="checkbox"/> YES <input type="checkbox"/> NO WERE THEY ACCESSIBLE? <input type="checkbox"/> YES <input type="checkbox"/> NO WERE THEY USED? <input type="checkbox"/> YES <input type="checkbox"/> NO	WERE THEY IDENTIFIED (Not FCC's or NHTSA's code)? <input type="checkbox"/> YES <input type="checkbox"/> NO <input type="checkbox"/> NOT APPLICABLE			

RESPONSIBILITY

ACCIDENT DESCRIPTION				
DESCRIBE WHAT HAPPENED (Sequence of events. Include Failure of Equipment. If diagram is needed attach separately. Continue on additional sheets if necessary.)				
VESSEL NO. 2				
NAME OF OPERATOR	ADDRESS	BOAT NUMBER		
TELEPHONE NUMBER		BOAT NAME		
NAME OF OWNER	ADDRESS			
WITNESSES				
NAME	ADDRESS	TELEPHONE NUMBER		
NAME	ADDRESS	TELEPHONE NUMBER		
NAME	ADDRESS	TELEPHONE NUMBER		
PERSON COMPLETING REPORT				
SIGNATURE	ADDRESS	DATE SUBMITTED		
QUALIFICATION (Check one) <input type="checkbox"/> CREWMAN <input type="checkbox"/> OWNER <input type="checkbox"/> INVESTIGATOR <input type="checkbox"/> OTHER		TELEPHONE		
FOR REPORTING AUTHORITY REVIEW (use agency data stamp)				
NAME OF REVIEWING OFFICE	DATE RECEIVED	CAUSES BASED ON (Check one) <input type="checkbox"/> THIS REPORT <input type="checkbox"/> INVESTIGATION AND THIS REPORT <input type="checkbox"/> INVESTIGATION <input type="checkbox"/> COULD NOT BE DETERMINED		
PRIMARY CAUSE OF ACCIDENT?		REVIEWED BY		
SECONDARY CAUSE OF ACCIDENT?				
PROPERTY DAMAGE (Est.)	PERSONAL PROPERTY DAMAGE			
THIS BOAT \$ _____ OTHER BOAT \$ _____ OTHER PROPERTY \$ _____		NAME AND ADDRESS OF OTHER (through Property)		
DECEASED				
NAME	ADDRESS	DATE OF BIRTH	WAS VICTIM <input type="checkbox"/> YES <input type="checkbox"/> NO	DEATH CAUSED BY <input type="checkbox"/> DROWNING <input type="checkbox"/> DISAPPEARANCE <input type="checkbox"/> OTHER
NAME	ADDRESS	DATE OF BIRTH	WAS DROWNED <input type="checkbox"/> YES <input type="checkbox"/> NO	DEATH CAUSED BY <input type="checkbox"/> DROWNING <input type="checkbox"/> DISAPPEARANCE <input type="checkbox"/> OTHER
NAME	ADDRESS	DATE OF BIRTH	WAS VICTIM <input type="checkbox"/> YES <input type="checkbox"/> NO	DEATH CAUSED BY <input type="checkbox"/> DROWNING <input type="checkbox"/> DISAPPEARANCE <input type="checkbox"/> OTHER
INJURED				
NAME	ADDRESS	DATE OF BIRTH	NATURE OF INJURY	INCAPACITATED OVER 24 HOURS <input type="checkbox"/> YES <input type="checkbox"/> NO
NAME	ADDRESS	DATE OF BIRTH	NATURE OF INJURY	INCAPACITATED OVER 24 HOURS <input type="checkbox"/> YES <input type="checkbox"/> NO
NAME	ADDRESS	DATE OF BIRTH	NATURE OF INJURY	INCAPACITATED OVER 24 HOURS <input type="checkbox"/> YES <input type="checkbox"/> NO

SAILOR'S WORKSHEET 2

1. Name the two basic kinds of hulls.

2. _____ hulls skim along on top of the water.

3. _____ hulls plow through the water.

4. Flat bottom boats: (a) plane (b) plow through water.

5. Round bottom boats are made to go: (a) fast (b) slow.

6. Most _____ have typical displacement hulls.

7. Displacement hulls are made to go at: (a) fixed (b) variable (c) unlimited speeds.

8. Why do boats have numbers?

9. Where can you go to get a Certificate of Number?

10. Boat numbers read from _____ on the port side of the boat and from

_____ on the starboard side of the boat.

11. What must you do if you sell your boat?

12. How big are the numbers on your boat supposed to be?

13. Write your state identification code.

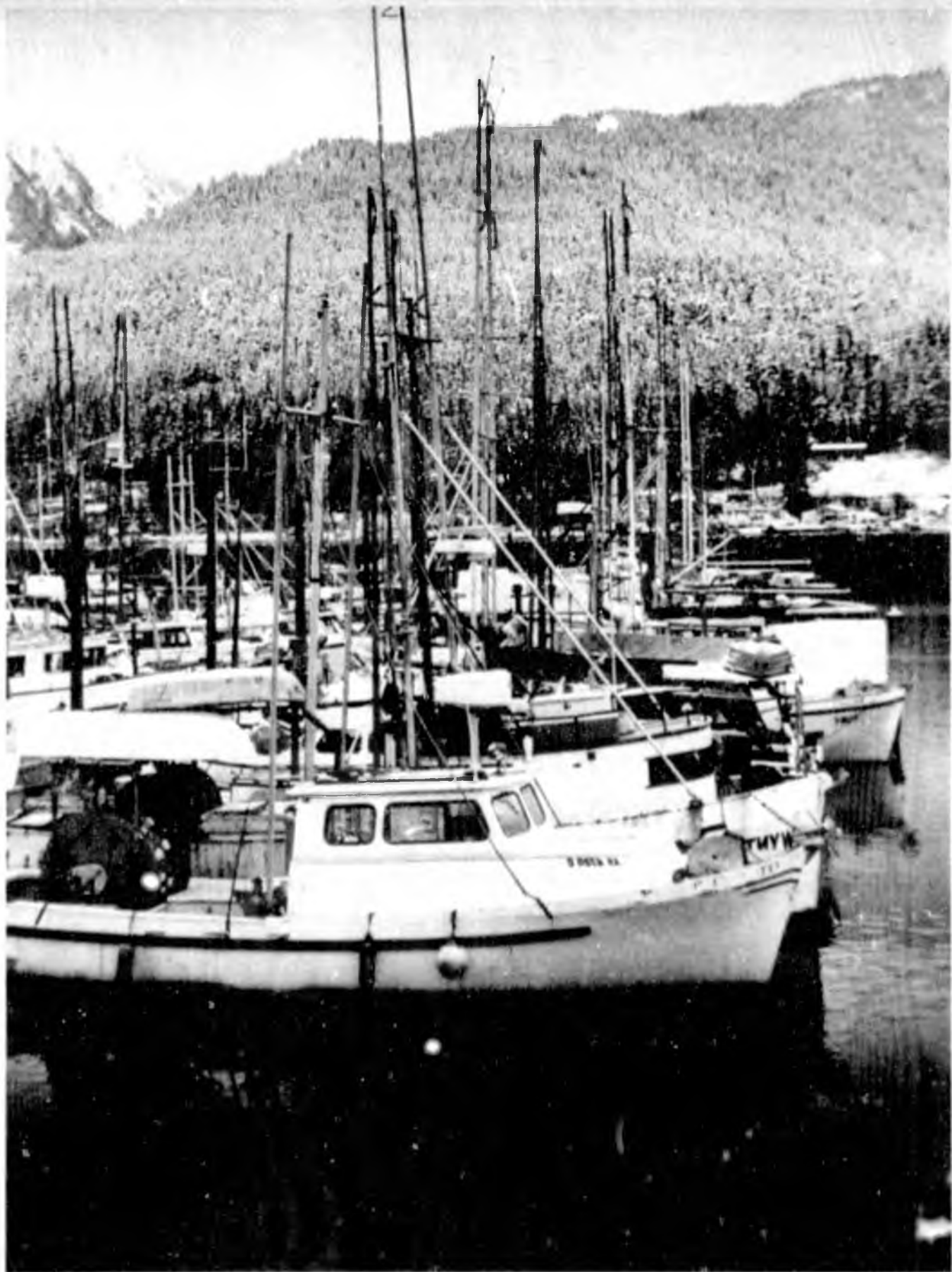

Part II



PERSONAL FLOTATION DEVICES

Personal Flotation Devices

You are required by Federal Regulations to have at least one Coast Guard approved Personal Flotation Device (PFD) for each person in your boat. You may not use your boat unless all your PFD's are in serviceable condition, are readily accessible, are legibly marked with the Coast Guard approval number and are of an appropriate size for each person on board.

There are several types of personal flotation devices [PFDs] which are one of the boater's most important pieces of safety equipment. They should be kept in serviceable condition and always be readily available.

Vests should be worn by all children and non-swimmers when underway. They should fit snugly.

Life Preserver - Type I

Type I PFD's may use kapok, fibrous glass and/or unicellular plastic foam. They are often jacket or bib design.

Both jackets and bibs come in child and adult size and are marked as such. A snug fit is very important. All approved life preservers are international orange in color.

Type I PFD's contain more than 20 pounds of buoyancy. They are the least comfortable to wear, but the most effective for long exposure and in rough water.

The Type I life preserver is designed to hold the wearer in such a position that, even if injured or unconscious, he will not drown. It has a righting moment which turns the person from a face down position to a face up position.

Buoyant Vest - Type II

Type II buoyant vests come in several designs and colors. Materials are similar to those used in life preservers.

A Type II PFD contains at least 15.5 pounds of buoyancy. It is not as effective as a Type I device in rough water or for long periods. However, a Type II device is more comfortable to wear and it still has a righting movement.

Both Type I and Type II PFD's are designed to turn an unconscious person face up or slightly backward in the water. Properly worn, they will keep a person's head and shoulders above water.

Neither a life preserver nor buoyant vest is intended as a swimming aid. A PFD is not a water toy.



Type III Devices

Ski Vests are Type III PFD's. They are more comfortable than other PFD types and have at least 15.5 pounds of buoyancy. They are designed for use in water skiing. A ski vest may not turn an unconscious person upright in the water. It should keep a conscious person in a vertical or slightly backward position.

Float coats, canoe vests, sailing vests and hunting vests are also Special Purpose Devices or Type III. These vests are more comfortable so that the boater always wears a personal flotation device while on the water. They will float a person's head out of the water in an emergency such as falling overboard or capsizing.

Throwable Devices - Type IV

Type IV devices include buoyant cushions and ring buoys. Throwable devices provide adequate support for a person in the water or in an emergency. They have a minimum of 16.5 pounds of buoyancy. They do not give the protection available from a life preserver or a buoyant vest.

Buoyant cushions are not recommended to use by children or non-swimmers. They are difficult to hang onto in the water. Do not wear a buoyant cushion for jumping into the water. Hold onto the cushion while entering the water. NEVER wear a cushion on the back. This tends to force the wearer's face into the water.

LIGHTS

Lights

By law, lights are to be exhibited when underway between sunset and sunrise. Light placement and requirements vary with the size and type of boats. There are two types of lighting requirements. These are the **Inland Rules** and the **International Rules**. The Inland apply only to inland waters. The International

may be used on inland waters by motorboats and required on the high seas (pg. 59).

All watercraft must display combinations of white, red and green lights shown below. No other lights which can be mistaken for these lights may be displayed.

DEFINITION: "10 pts. 1 mi." means that the light can be seen by another vessel through an arc of 10 points for a distance of 1 mile.

VESSELS USING ONLY INLAND WATERS

LESS THAN 26 FEET

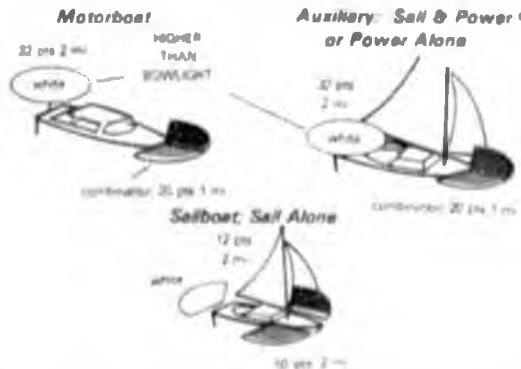

NOTE: Auxiliary sailboats under sail alone need not show the 12 pt. stern light but may in lieu of carry, ready at hand, a flashlight or lantern to be exhibited in sufficient time to prevent collision or the appropriate international lights may be shown for a vessel of its size.

26 FEET TO NOT MORE THAN 65 FEET



EXCEPTIONS: 1) Western Coast Rules: sidelights for vessels under sail must be visible for 3 miles. 2) Great Lakes Rules: sailing vessels may show a white light in lieu of a stern light upon that portion of the vessel which is being approached by another vessel.

ANCHORED OR ROWING

POWER BOATS under 65 feet and all sailing vessels at anchor must display anchor lights except those under 65 feet in "special anchorage areas". An anchor light is a white light visible to a boat approaching from any direction and is displayed in the fore part of the vessel.



ROWING BOATS, whether under oars or sail, shall have ready at hand a lantern showing a white light which shall be temporarily exhibited in sufficient time to prevent collision.

VESSELS USING INTERNATIONAL WATERS

LESS THAN 12 METERS

Carried at Least
1 Meter Higher
than Colored Lights

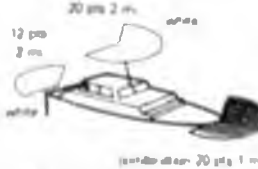

12 TO 20 METERS

Carried at Least
2.5 Meters Above
the Gunwale

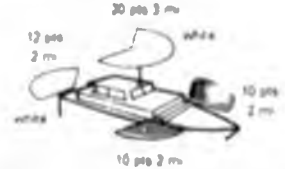

NOTE: A power driven vessel of less than 7 meters in length and whose maximum speed does not exceed 7 knots may in lieu of the lights prescribed above exhibit an all around white light. Such vessel shall, if practicable, also exhibit sidelights. All vessels less than 20 meters may display either separate colored sidelights or combined lanterns. All vessels under power, whether under sail or not, are to be considered power driven vessels.

VESSELS UNDER SAIL ALONE

Vessels Under 20 Meters

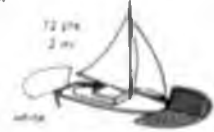

OPTIONAL for all sailing vessels.

OPTIONAL for sailing vessels less than 12 meters: Comb. red, green and white light 32 pts 1 mi.

A sailing vessel of less than 7 meters in length or a vessel under oars shall, if practicable, exhibit the lights prescribed above. If she does not, she shall have ready at hand an electric torch or lighted lantern showing a white light which shall be exhibited in sufficient time to prevent collision.

NOTE: Sidelights of vessel less than 12 meters must be visible for at least 1 mile.

WHEN ANCHORED

Power-driven vessels and **sailing vessels** less than 20 meters in length at anchor must display anchor lights. Vessels less than 7 meters in length shall not be required to display anchor lights unless anchored in or near a narrow channel, fairway or anchorage or where other vessels normally navigate. An anchor light is a white light visible for 2 miles to a boat approaching from any direction.

ADDITIONAL EQUIPMENT

Carburetor Backfire Flame Arrestors

Internal combustion engines at times backfire. To safeguard against fire, all motorboats, except outboards and diesels, must have a Coast Guard approved carburetor backfire flame arrestor.

Ventilation

Regulations require ventilation of motorboats if engine and fuel compartments are closed. However, a ventilation system is not required if the boat does not trap explosive or flammable vapors.

STERN DRIVE VENTILATION

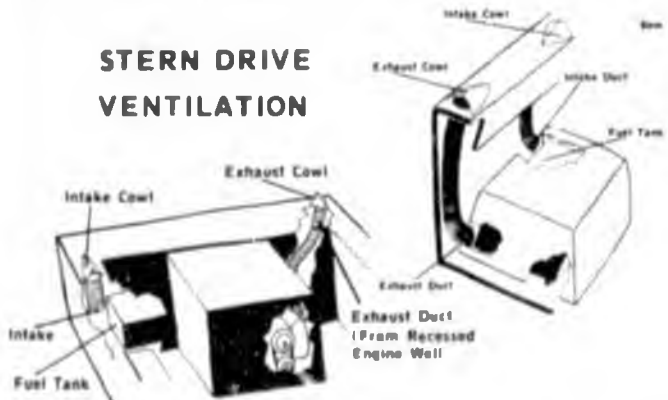

Intake ducting must extend from cowls at least midway to bilge, or at least below carburetor air intake level. Also, exhaust ducting must extend from lower bilge to cowls in the atmosphere.

Mufflers

Noise from a poorly muffled or unmuffled motor disturbs others. More important, it can prevent the

INBOARD CRUISER VENTILATION

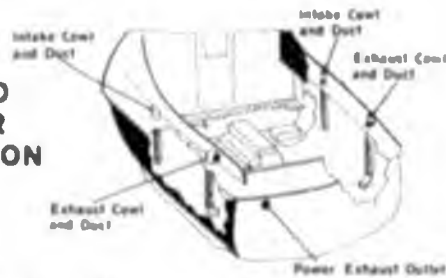

MOTOR SAILER VENTILATION

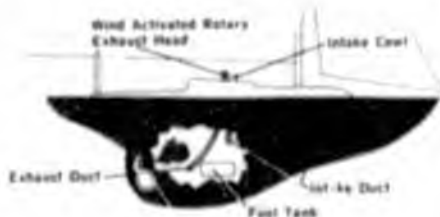

motorboat operator from hearing voices, signals or sounds that might alert him to danger.

Whistles and Horns

Every motorboat 16 feet (5 meters) and over must have a whistle or horn. Federal regulations specify the type required.



Bells

Boats 26 feet and over must be equipped with a bell that gives a clear tone when struck. When at anchor during fog, mist, falling snow or heavy rainstorms, the boater must ring the bell rapidly about five seconds at one minute intervals. This must be done whether day or night.

Illegal Equipment

Safety patrols and emergency craft are the only boats allowed to use sirens or flashing blue lights.

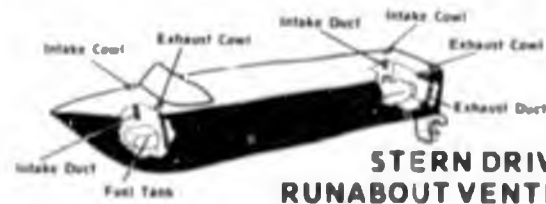

STERN DRIVE RUNABOUT VENTILATION

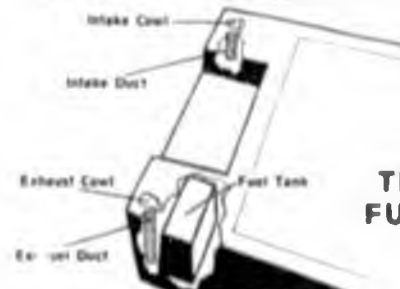

TRANSOM FUEL TANK

FIRE

Fire Extinguishers

Fire and explosion causes more total property loss on boats than any other mishap.

When gasoline leaks or spills, the vapors are heavier than air. They collect in the lowest part of the boat, usually the bilge. This vapor is more explosive than gunpowder. One cup of gasoline creates vapors more destructive than 15 sticks of dynamite. Never use matches or flames of any type near gas pumps, lines or tanks.

Boat fires also may be caused by electrical wiring. Usually the current overloads the wire. The wire gets hot and sets the insulation on fire. An extinguisher must be able to put out this fire without giving the user a shock.

Caution: The use of water to extinguish a petroleum fire will usually cause a boat fire to spread.

Law Concerning Extinguishers

All motorboats shall carry fire extinguishers approved by the U.S. Coast Guard. Exceptions are outboard motorboats less than 26 feet in length without permanently installed fuel tanks and which do not have spaces in which explosive or flammable fumes can collect. The minimum size of fire extinguishers approved for use on motorboats are hand portable, either B-I or B-II classification, and are listed below:

Class of motorboat	Without fixed system in machinery space	With fixed system in machinery space
A (less than 16 ft.)	1 B-1	None
1 (16 to under 26 ft.)	1 B-1	None
2 (26 to under 40 ft.)	2 B-1 or 1 B-II	1 B-1
3 (40 to 65 ft.)	3 B-1 or 1 B-II and 1 B-1	2 B-1 or 1 B-II

Approved Extinguishers

All extinguishers must be readily accessible (preferably not stowed next to common fire sources), and they must be kept in a serviceable condition. **REMEMBER**, the number required by law is the minimum. Extra extinguishers provide additional safety.

In addition to labels or any other markings, the extinguisher must bear the label of a testing laboratory which will include either Coast Guard

Classification (type-size)	B-1	B-II
Dry Chemical (minimum lbs.)	2	10
Foam (minimum gals.)	1½	2½
Carbon Dioxide (minimum lbs.)	4	15
Freon Type (minimum lbs.)	2½	None

approval numbers or specify "Marine Type USCG." All Carbon tetrachloride extinguishers and others of toxic vaporizing-liquid type such as chlorobromomethane are not approved and are not accepted as required fire extinguishers on any motorboats.

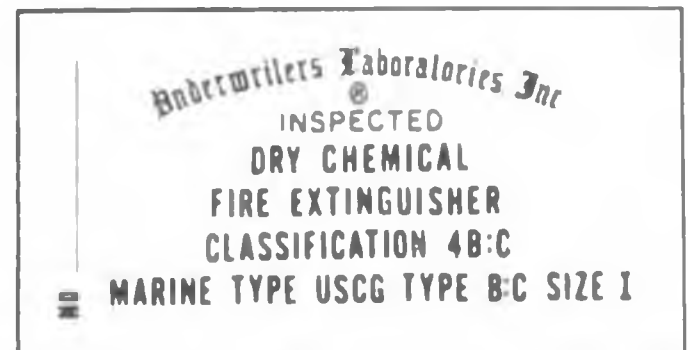

Types

Dry Chemical: Dry chemical extinguishers have two basic parts; a cylinder containing the extinguishing agent, and the valve assembly. The chemical is kept under pressure, and in most cases a gauge or visual indicator is attached to the valve assembly or cylinder to show the expellant charge. Some extinguishers manufactured prior to June 1, 1965 do not have visual indicators, and must be weighed semi-annually to determine their serviceability. Such extinguishers must have a service tag attached indicating service within the last six months. All dry chemical extinguishers should be frequently examined by the boatman for signs of leakage (dry chemical in the nozzle, etc.). During this check, the boater should remove extinguishers from their brackets and shake them vigorously to loose any chemical that might be compacted.

FIRE



Carbon Dioxide Extinguisher



Dry Chemical Extinguisher

Carbon Dioxide Extinguishers: CO2 extinguishers have three basic parts; body, valve assembly and discharge horn. These extinguishers are checked by weighing only. If the total extinguisher weight (gross weight) is reduced by more than 10 percent of the net weight marked on the extinguisher, it is not sufficiently charged and is no longer acceptable. This type of extinguisher is best for use in closed areas and is effective on all types of fires. It is not harmful to clothing, mechanical or electrical parts.

Foam Extinguishers: Foam extinguishers have four basic parts; the tank, ring top, head stopple and inner container. These extinguishers are required to be serviced annually. Periodic checks by the boater should include visual examination of the water level in the tank and the hose. These extinguishers are not recommended for electrical fires.



Freon Type Extinguisher



Foam Extinguisher

Freon Extinguishers: Freon extinguishers have four basic parts; body, valve assembly, visual gauge and discharge horn. The freon extinguisher, like the CO2 does not harm clothes, electrical or mechanical parts. These extinguishers should be periodically checked for corrosion and obstructions in the discharge horn. Freon type extinguishers are effective on all types of fires and are best for use in closed areas.

Fire Prevention

The best time to become concerned with fire is before it happens. Almost everyone knows something about fire prevention but many boaters have a false sense of security with all of the water around. Remember, **MOST FIRES ARE PREVENTABLE.** Here are a few easy checks and precautions:

1. Keep your entire fuel system in good condition. Check tanks, lines, connections, fuel pump and carburetor periodically for leakage. If a leak is spotted, stop the flow, wipe up the spill, discard the cloth in a safe place, ventilate the area until the smell of gas is gone...then get underway. **LISTEN TO YOUR NOSE!**
2. When fueling your boat, turn off all electrical and internal fuel systems (heaters, stoves, refrigerators). Pilot lights and galley stoves have caused many deaths at the fuel dock. Before leaving the fuel dock, all boat spaces should be ventilated. If your boat is equipped with a blower, make sure that it is run five minutes before you depart.
3. **KNOW HOW TO USE YOUR EXTINGUISHERS.** All hands should read the instructions for use printed on the extinguisher. If a fire occurs, determine its source. Do not discharge the extinguisher merely in the general direction of the fire, but rather at the base of the fire, in sweeping motions. This is the most effective action to suffocate the fire at its source.

The Fire Triangle

Fuel, heat and oxygen are necessary for fire. Eliminate any one and the fire will go out. Fires are usually extinguished by cooling, smothering or both. The dry chemical, carbon dioxide and foam fire extinguishers do both. For oil and grease fires, direct these agents at the base of the fire.

The three types of fires are combustible materials such as rags or wood; combustible liquids such as gasoline or alcohol; and electrical. Dry chemical, carbon dioxide, foam and freon extinguishers may be used on any of these fires. The most common fire extinguisher is carbon dioxide.

Never use water on a gasoline, oil, grease or electrical fire. Water will spread the first three elements. Since water is a conductor you may receive a damaging shock from an electrical fire. Water can be used to extinguish burning wood, mattresses, rags, paper, rubbish and alcohol.

FIRE

What are the three elements of the fire triangle?

The Fire Triangle



Eliminate any one and the fire will go out.



Even if a fire appears to be out, it may smolder for a long while and start up again. If possible, soak burning materials over the downwind side of the boat. When the emergency is ended, retrieve refuse to avoid littering the waters.

Follow these steps if fire breaks out underway:

1. Slow or stop the boat. Wind from the boat's motion fans the flames.
2. Keep the fire downwind. If the fire is aft, head the bow into the wind. If forward, put the stern into the wind.
3. If the motor catches fire, shut off fuel supply immediately.
4. Display distress signal.
5. Fight the fire.

These actions help prevent the fire from spreading to other parts of the boat.

Before fire breaks out, plan ahead. Decide what should be done to combat a fire in any part of the boat. Always be sure safety equipment is in good working order.

Fueling

Extremely hazardous conditions exist and are often encountered when fueling. Safety rules should be rigidly observed. When taking on gasoline, all engines should be stopped, galley flames extinguished, hatches, windows and ports secured and electrical devices shut off. No smoking should be allowed. Diesel fuel, being less flammable, is not as hazardous as gasoline, however, observing the same safety rules

is advisable and should contribute to development of "the safety habit".

The gasoline nozzle should contact the fillerpipe deck flange at all times during fueling to prevent the possibility of explosion associated with the spark of static electricity. (Similar precautions should be observed when fueling tanks used with outboards.) The fillerpipe deck flange should be connected to the boat's ground system. Static electricity is generated internally throughout the length of the gas hose by the motion of gasoline and by atmospheric conditions. Modern fuel pump equipment has been designed to prevent this discharge and the danger is, therefore, less than in the past, however, safety precautions are still considered an absolute necessity.

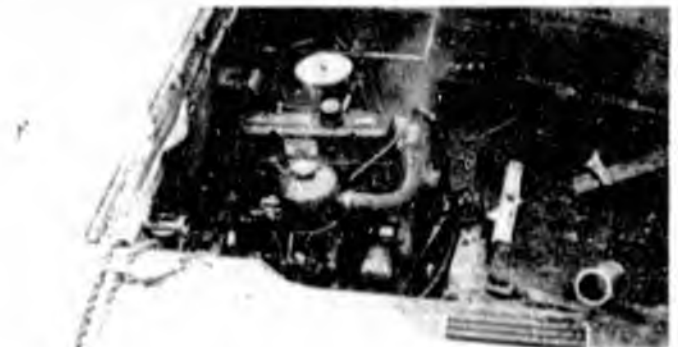

Space should be allowed for fuel expansion. The tank should not be filled to capacity. Approximately five percent should be allowed, based on the average of fuel expansion. It is not necessary to mathematically compute the fuel expansion, experience can be the controlling factor.

When the fueling operation has been completed, any spillage should be wiped up immediately. Exhaust blowers should be operated for a minimum of five minutes before starting engines. This is sometimes difficult to accomplish when the dock is crowded and other boats are waiting to fuel.

It is important to be thoroughly familiar with the



FIRE

dangers of handling gasoline and the necessary precautions to reduce the risk of fire. Become acquainted with the most effective means of extinguishing a gasoline fire. Gasoline explosions and fires are the leading cause of property damage and one of the significant causes of loss of life and injury on small boats. Gasoline is used as fuel on the majority of motorboats now in operation, and the boat operator constantly faces the potential hazards of gasoline fire or explosion.

The following Rules for Fueling are reprinted from a publication of the National Fire Protection Association and should be thoroughly learned by every boat operator:

1. Fuel tanks should be properly installed and vented overboard.
2. Fueling should be completed before dark except in emergencies.

3. Whenever a boat is moored at service dock for fueling:
 - a. Do not smoke, strike matches or throw switches;
 - b. Stop all engines, motors, fans and other devices liable to produce sparks;
 - c. Put out all lights and galley fires.
4. Before starting to fuel:
 - a. See that the boat is moored securely;
 - b. Close all ports, doors and hatches;
 - c. Ascertain definitely how much additional fuel the tanks will hold.
5. During fueling:
 - a. Keep the nozzle of the hose, or can, in contact with the fill opening to guard against possible static spark;
 - b. See that no fuel spillage goes into the hull or bilges.

Student Activity Which requirements apply to your boat?

Coast Guard Requirements / Minimum Required Equipment

EQUIPMENT	CLASS A (less than 16 ft.) (less than 5m)	CLASS 1 (16 to less than 36 ft.) (5 to less than 11m)	CLASS 2 (36 to less than 66 ft.) (11 to less than 20m)	CLASS 3 (66 to not more than 95 ft.) (20 to not more than 29m)
BACK FIRE FLAME ARRESTOR	One approved device on each carburetor of all gasoline engines installed after April 25, 1940, except outboard motors			
VENTILATION	At least two ventilator ducts fitted with cowls or their equivalent for the purpose of properly and efficiently ventilating the spaces of every engine and fuel tank compartment of boats constructed or decked over after April 25, 1940, using gasoline or other fuels having a flash point of 110° or less			
PERSONAL FLOTATION DEVICES (PFD)	One approved Type I, II, III or IV device, for each person on board or being towed on water skis, etc.	One approved Type I, II or III device aboard for each person and, in addition, one throwable Type IV device		
BELL WHISTLE	All boats must be able to produce navigational signals under rules of the road	Whistle — one hand, mouth, or power operated, audible at least 1/2 mile	Bell — one, which when struck, produces a clear, bell like tone of full round characteristics One hand or power operated, audible at least 1 mile	One power operated, audible at least 1 mile
FIRE EXTINGUISHER PORTABLE <small>When NO fixed fire extinguishing system is installed in machinery spaces)</small>	At least one B I type approved hand portable fire extinguisher (Not required on outboard motorboat less than 26 feet in length and not carrying passengers for hire if the construction of such motorboats will not permit the entrapment of explosive or flammable gases or vapors.)		At least two B I type approved portable fire extinguishers; OR At least one B II type approved portable fire extinguisher.	At least three B I type approved portable fire extinguishers, OR at least one B I type Plus one B II type approved portable fire extinguisher.
<small>When fixed fire extinguishing system is installed in machinery spaces)</small>	None	None	At least one B I type approved portable fire extinguisher	At least two B I type approved portable fire extinguishers, OR at least one B II type approved portable fire extinguisher
	B I Type Approved Hand Portable Fire Extinguishers contain: Foam, 1 1/2 up to 2 1/2 gallons, or Carbon Dioxide, 4 up to 18 pounds, or Dry Chemical, 2 1/2 up to 18 pounds, or Foam 2 1/2 lbs.		B II Type Approved Portable Fire Extinguishers contain: Foam, 2 1/2 gallons, or Carbon Dioxide, 15 pounds, or Dry Chemical, 10 pounds.	

MAINTENANCE

Take Care of Your Boat

"Take care of your boat and it will take care of you," is more than just a saying. Marinas, service stations for boats, can be a long way apart. There are no phone booths on the water and passing traffic can't always be counted on. The boater must know how to do things for himself.

To finish a boat trip the way you planned it, two things must happen: The boat must float and the engine must run. Unless you've already capsized, the first problem you'll see to indicate the danger of sinking is water in the bilges, or bottom, of the boat.

Find out where it's coming from — fast! Get life-saving and survival gear ready first. Then find the leak. Check all hull fittings quickly. Be sure you already know what and where they are.

The leak could be coming from: engine water intake, head intake, and discharge, depth finder transducer, rudder post, propeller shaft, bilge pump or galley drains. If the engine water intake line is broken, or any part of the cooling system has sprung a leak, running the engine can pump water into the boat.

If the leak is from a hole in the hull, plug the hole with blankets, clothes or even magazines. If possible, cover the hole with plastic sheeting or a plastic bag from the outside. Head for shore or nearest boat.

Don't wait for an emergency. Take preventive care of your boat. An annual inspection should be made for loose fittings on the hull. Engine and propeller units should be checked regularly.

Whenever you have your boat out of the water check underwater parts for damage. Before you start your engine look for signs of needed repairs.

Check for oil in the bilges every time you set out. Check the dipstick to be sure oil level is high enough. Beware if it goes over the full mark or drops quickly. Watch oil for discoloration or beads of water.

Make sure batteries are properly filled and cables are free of corrosion. A simple cotterpin missing from shift or throttle controls can cause an accident.

Use your nose every time you lift an engine cover or raise a hatch. Sniff for: gasoline, propane, butane, electrical shorts, overheated engine or transmission, stagnant water in the bilges. These smells signal a need for maintenance.

Before you push the starter, run the blower for five minutes with engine hatch open. Whenever you push the starter or turn the key, listen to the engine as it cranks and begins to fire. If it sounds "different" from usual, there may be trouble somewhere.

You don't have to be a trained mechanic to find a problem. Listen, smell, watch and feel. Your boat's talking to you when it doesn't steer properly, shifts hard, backfires or is sluggish.

If you think you have a problem, ask your mechanic or another boater. You'll soon learn to identify important problems and be able to correct many of them yourself. With good maintenance and regular inspection, your boat will be safe and more enjoyable for you and your crew.

Fuel Saving Tips

MAINTENANCE

1. Keep engine well-tuned.
2. Use correct propeller and check it for damage. A nicked or bent propeller slows down the boat and may damage the engine.
3. Be sure engine matches boat. Check mounting for proper tilt.
4. Use proper oil mix in motor. Pour fuel carefully. Reset cap tightly. Keep vent screws closed when not operating to prevent evaporation. Don't overfill to allow for heat expansion.
5. Keep hull clean to reduce friction.

ON THE WATER

1. Drain all water before starting out.
2. Distribute weight properly. Unload excess gear. Don't overload with passengers.
3. Shut off engine when at dock or at rest.
4. Drive in straight line—turns increase motor load.
5. Don't jam throttle ahead at take-off. Plane smoothly and quickly, then throttle back to three-fourths when boat is planed. Most boats operate as well at three-fourths throttle and use half as much fuel. Also applies to water skiing.
6. Plan fishing spots ahead of time. Use trolling motor for minor changes in location.

SAILOR'S WORKSHEET 3

1. Gasoline vapors can be as explosive as _____.
2. Most fires aboard a boat are caused by _____.
3. Where should you fill portable outboard fuel tanks? _____
4. Boat windows, doors and other openings should be: (a) open (b) shut during refueling.
5. What are the three elements of the fire triangle?

6. Fire extinguishers aboard a boat must be kept _____.
7. What are some things you can do to protect your boat against fire? _____

8. What should you do if you spill gasoline aboard a boat? Why?

9. When must a boat show lights? _____
10. How are fire extinguishers classified?

11. A backfire flame arrestor helps reduce the chance of _____.
12. The use of a boat whistle, horn and bell, and signals, indicate (name five):

13. What do the letters PFD signify? _____
14. What is the requirement for PFD's on a boat 16 feet or over? _____

15. Name and describe 4 different types of Coast Guard approved life saving devices:

16. What should you do with a PFD that has become badly torn, stiff or heavy.

17. The survival suit is (a) an approved PFD (b) not an approved PFD.

TRAILERING

Trailer Safety

Your boat trailer is an important part of your boating equipment. All too often, the trailer does not receive the attention that it deserves and demands. After selecting the proper trailer for your boat, continual care in hitching, towing and maintaining is necessary. If any of these areas are neglected, you may be endangering the safety of your boat, your car, your family and yourself.

Normally, the length of the boat determines the length of the trailer. The beam (width) determines the width of the trailer. The boat should fit snugly on the trailer when it is cranked up to the winch support. There should be proper support for the boat's bottom. Most trailers have adjustable rubber rollers with nylon bushings or wooden chocks which are cushioned. These help absorb road shocks and prevent transmission of the shocks to the boat's hull. These supports must be aligned properly to prevent warping the hull.

The first time the boat is placed on the trailer, the rollers and supports should be adjusted to conform to the boat's bottom, and the bolts tightened securely. After the initial adjustments are made, they will probably not need further attention except to check the bolts from time to time to be certain that they haven't worked loose.

Proper tie downs should also be considered in choosing a trailer. Sufficient support for each side of the hull is essential to prevent the boat from shifting while it is on the trailer.

Trailer Load

The trailer must be strong enough to carry the weight that will be placed on it. The load capacity of a boat trailer should not be exceeded. Most trailers will have a data plate that states the maximum load capacity and the correct specifications for the tires. If your trailer does not have such a plate, consult other sources or your dealer for this information. Remember, the "load" placed on a trailer includes the weight of the boat, the engine and all gear that is loaded into the boat. Equal distribution of items placed inside the boat is of vital importance.

While trailering, many boaters haul most of their gear in their boats. If this is done, the load should be distributed so that the heaviest items are placed on the bottom of the boat, directly over a supporting roller or chock. The gear should be secured carefully to keep it from shifting around.

Hitching the Trailer



Trailer hitches come in a variety of shapes and sizes. Most boat trailers connect to a ball hitch that is bolted or welded to the towing vehicle. Clamp-on-bumper hitches are not recommended for heavy loads or continual towing. Special heavy duty equalizing hitches are a necessity for trailer tongue weights (the weight a loaded trailer places on the hitch of the towing vehicle) of 250 pounds or greater. The trailer hitch itself should match the size of the ball hitch; NEVER use a ball hitch that is too small. Solid steel ball hitches are preferable.

Tongue Weight

Too much weight on the hitch will cause "tail dragging" of the towing vehicle, impairing steering and raising headlights into the eyes of oncoming traffic. Too little or negative weight on the hitch, and the trailer will sway or "fishtail". The solution to proper distribution is often adjusting the wheel carriage either forward or back. If the carriage cannot be adjusted, relocate movable gear. If this fails to correct the problem, consider another trailer of different design.

Couplings

The coupling hitch on the trailer should have a lock or provisions to prevent loosening due to vibration. Lubricate the hitch for longer wear, quiet turns and to prevent corrosion.

Safety Chains

The trailer must be equipped with at least one, preferably two, safety chains. They should be strong enough to control the trailer if the regular hitch or coupling breaks. Hook the chains in the form of an "X" to the frame of the towing vehicle. Use a bolt to secure the safety chain to the tongue. The chain must have a breaking strength of at least the gross weight of the trailer; solid link chain is best.

Lights

Alaska state law requires two red taillights on the rear that may be combined with the stop and turn signals. Vehicles over 80 inches in width require

TRAILERING

clearance lights. If lights are dunked, waterproof light fixtures should be used. If water is allowed to enter, the lamp may crack and short out the entire lighting system. Water also promotes contact corrosion. Always carry spare lamps. The wire coupling to the towing vehicle should be high enough to stay dry. Never rely on the trailer hitch for ground connection. Four-pole connectors should be used.

Tires should ALWAYS be inflated to manufacturer's recommended pressure. Always carry a spare wheel, jack and bearings that fit the boat trailer. If wheel bearings are always dunked, waterproof bearings and caps should be considered. If water is allowed into the hub, lubricating grease will float away and bearings will burn out or seize, causing damage and a safety hazard. Waterproofed bearings should be inspected prior to each boating season, others more often. Special care should be given when traveling on unimproved roadways with small-diameter wheels.

Car Carrying

1. Protect car top with a carrier or cushion material.
2. Alaska state law requires:
 - a. The driver's vision must not be obscured.
 - b. The boat being carried may not extend more than 3 feet in front and no more than six feet beyond the rearmost limits of the body of the vehicle.
 - c. The vehicle and boat's height may not exceed 13½ feet; total width may not exceed 8 feet.
 - d. The object carried may not obscure the vehicle's front or rear lights.
 - e. The boat must be tightly secure and visible to all traffic (reflectors, flags, lights).

Towing

Boat trailers must be licensed just as automobiles. Alaska, like most states, has regulations pertaining to trailer ownership and operation. Periodic vehicle inspections made by law enforcement agencies also include boat trailers. Particular emphasis is placed on lights and reflectors, towing hitches, brakes, safety chains, size limitations and weight.

Extra caution is necessary when towing any trailer. The heavier the rig, the more time required to accelerate, pass and stop. For this reason, the maximum speed for vehicles with trailers is 55 miles



per hour. A long rig requires a larger turning radius. Curbs and obstructions should be given wide clearance. Most boats on trailers obstruct the rear view of the driver. When this happens, an additional rear view mirror on the right side of the towing vehicle is required by law. The trailer boatman should be familiar with traffic and highway laws relating to the towing of trailers.

Trailer Hints

The simplest precautions, if observed, will make trailering a boat a pleasant and relaxing experience. The first emphasis would be that the car is capable of the pull required.

Avoid sudden stops. Always allow extra following distance.

If you are passed, air turbulence from a large vehicle will push the trailer to the right. DON'T BRAKE. This gust will move along the trailer immediately and will tend to correct the sway. If you are not traveling at the average speed of traffic on the highway, pull over at the first safe chance to allow others that may be following to pass.

When passing, remember that the trailer adds weight and will reduce acceleration, with this in mind, more room is needed for overtaking. Always change lanes smoothly to avoid whipping the trailer.

Trailer wheels and car wheels do not follow in the same path. One must steer wider on corners and the trailer will stay clear of the curb or other vehicles. On curves, stay well on your side of the center line.

Practice backing maneuvers in an open area. When backing, do not rush. Remember that the trailer will turn in an opposite direction than the car. AVOID

TRAILERING

OVERSTEERING. It is a good idea to have someone outside of the car to help give directional guidance.

If a car engine should ever overheat, do not remove the radiator cap, have the engine idle rapidly to increase air flow. Remember to shut off your air conditioning until the idling temperature returns to normal. Cold water should not be poured over or into a hot engine. Transmission coolers are recommended for towing heavy loads, for long distances or during hot periods.

Launching and Retrieving

Prepare boat for launching at the top of the ramp or parking facility. Remove all tie-down straps, check boat plugs and fasten boat painter. Do not release winch line until boat is in the water. Back trailer to the left if possible; backing left gives better launching visibility. Avoid dunking wheel bearings where possible. Never leave the towing vehicle unattended on the ramp with only the parking brake set. If vehicle must be left while on the ramp, set transmission in "park" or first gear, in addition.

In retrieving your boat, make sure that the boat is properly placed on the trailer. Secure winch line to the bow eye. Pull trailer up steadily to prevent spinning the wheels.

Trailer Safety Precautions

Before leaving home:

1. Be sure that the boat is secured properly on the trailer.
2. Inspect all lines, tie-downs and the winch. Tighten as necessary and replace any that show signs of fraying or strand separation.
3. Determine that all trailer lights are operating satisfactorily.
4. Test the braking system.
5. Inspect the hitch and safety chain.
6. Check tires: pressure, lug bolts and the possible need of tire rotation.

On the road:

1. Drive carefully, allowing for the extra length of the car and trailer when negotiating turns and when passing.
2. Allow more time for stopping.
3. Watch speed limits.
4. Pull well off the road periodically and walk completely around the rig. Examine the tires, the wheel bearings for overheating, test the tie-downs and check any gear which is being carried in the boat.

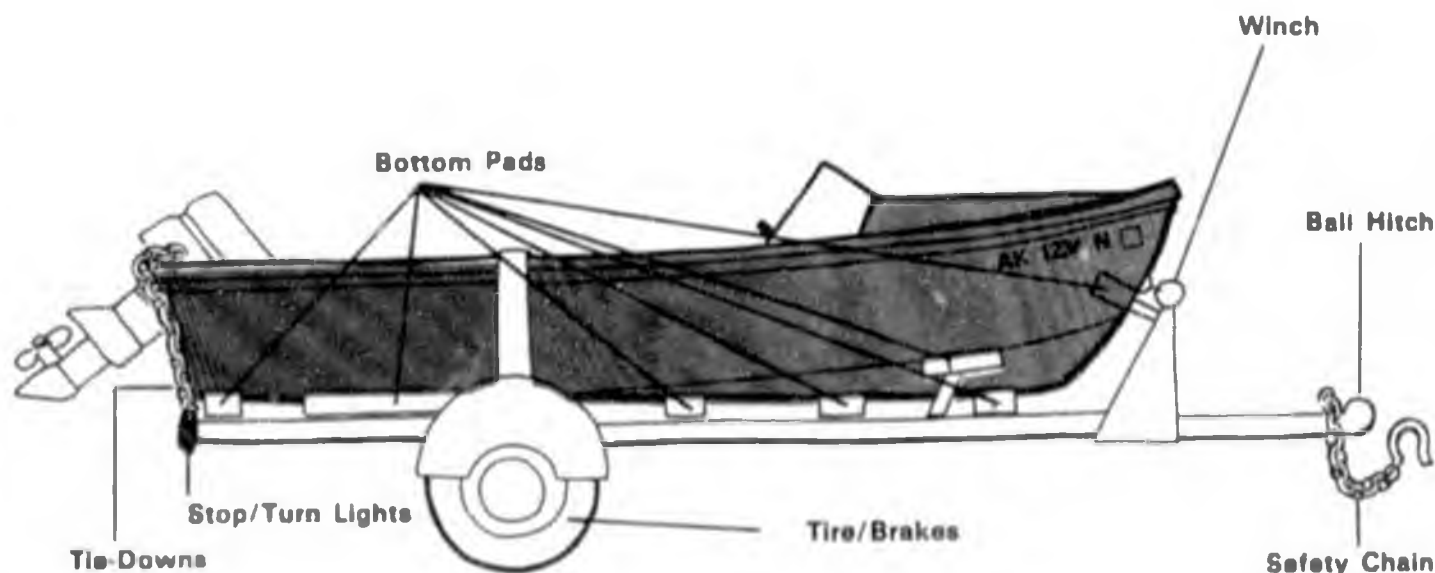

SAILOR'S WORKSHEET 4

1. List at least four parts to check before pulling a boat trailer.

2. Trailers give support to the boat's:

(a) rigging (b) cockpit (c) bottom.

3. Light items (a) may (b) may not be carried in the boat when trailering.

4. The ball hitch used on the towing vehicle should match the size of the _____ hitch.

5. The best method to attach a towing hitch, would be to the car's: (a) frame (b) bumper.

6. Why is a safety chain on your trailer hitch necessary?

7. When pulling a boat trailer you should carry a _____

8. List two ways you can care for your trailer tires. _____

9. To safely and legally tow a boat and trailer which obstructs the rear view, an additional mirror on the _____ side of the car is required.

10. Trailer wheels do not follow the path of car wheels, so you must steer _____ on corners.

11. You need more room to pass other cars when towing because _____

12. When towing a trailer, one should avoid stopping _____ and be sure to allow plenty of _____ between you and the car ahead.

13. If your car engine overheats while you are towing a boat you should _____

14. The vehicle and boat may not be higher than _____ nor wider than _____

15. Be sure the car top boat does not extend more than _____ in front of the vehicle.

16. The car top boat may not extend more than _____ beyond the rearmost limits of the body of the vehicle.

17. Give two examples of assuring that the boat is visible.



Part III



NAVIGATIONAL AIDS

Navigational aids or signposts are similar to traffic signs. They help guide boaters on bodies of water by:

1. Finding location
2. Warning of danger
3. Guiding the boat from place to place
4. Pointing out special marine situations

Aids may be natural structures. Usually, they are artificial markers. They may be floating or non-floating. They are installed and maintained by the U.S. Coast Guard, state or local agencies.

Natural aids are land features such as high peaks, bluffs or beaches. They can also be manmade structures like tall buildings or bridges.

Artificial markers may be lighted or unlighted. Different shapes, sizes and colors mean different directions. Markers are found in the water and along the shore. All boaters should memorize the navigational aids that apply to the waters they travel.

Visual aids include minor and range lights, lighthouses, buoys, signs and daymarks. Electronic and audio signals include radio beacons and fog signals.



Minor Lights

These structures may be painted similarly to lighthouses. They are often black or red, following the buoyage marking system. These lights may have low-powered, continuously operating radio beacons and fog signals.

Range Lights

Range lights may be white, red or green and may be fixed or flashing. They are arranged so when in line (one over the other) they indicate the boater is on a safe course. They are usually visible only in one direction. By steering a course to keep these lights in line, the boater will remain within the channel. Many range lights are located on shore, so a chart is necessary to determine where to change course.

Lighthouses

Lighthouses are found along the coasts and on some interior waterways. They are placed on prominent

headlands, at harbor entrances or on isolated dangers. These structures are painted solid colors or with bands or patterns. The lights have colors and flashes which, with the painted patterns, help identify individual lighthouses.

Radio Beacon

Radio beacons are located at many lighthouses, and shore stations. They emit radio signals in the 286 to 324 kilocycle range. Accurate use is limited to about 100 miles. Small craft operators make good use of the system, which is simple to operate and relatively low cost.

Fog Signals

Most lighthouses and some buoys and minor lights are equipped with sound. These aid the mariner when visibility is low. Charts and light lists for the area should be used for positive identification. **CAUTION:** Buoys fitted with bells, gongs or whistles sounded by wave motion may ring at irregular intervals. Positive identification is not always possible.

Buoys

Buoys are artificial markers. They use color, shape, numbers, light and sound to guide boaters along a safe course. Used with the right charts, they help find position. When visibility is low, buoys with gongs, bells or whistles indicate danger to boaters.

Red Right Returning

Seafarers use the phrase "red right returning" to remind them of the correct course among red and black buoys. It means that red buoys are always passed on your right or *starboard* side when returning to port from open sea (or upstream.) The opposite also holds true. When leaving port toward sea, red buoys are left and black buoys are starboard. Red buoys are always even-numbered. Black buoys are odd-numbered.

On some channels it is difficult to determine the seaward direction. On these waters you must compare the aids you see with a nautical chart. Some examples of these are the Atlantic and Gulf coasts and the Great Lakes.

On most rivers it is assumed that red is to starboard (right) while proceeding from sea to river head. Don't be confused by local terminology that describes left bank and right bank with the flow of the river. To be sure, use a nautical chart.

Sometimes buoys are missing, adrift, or off the chartered position or station. Heavy storms, ice flows or collisions may move a buoy. Even buoys on the correct station should be passed at a distance. They may be very close to the danger they mark. Report misplaced buoys to the proper authorities.

NAVIGATIONAL AIDS

Federal Channel Marker System

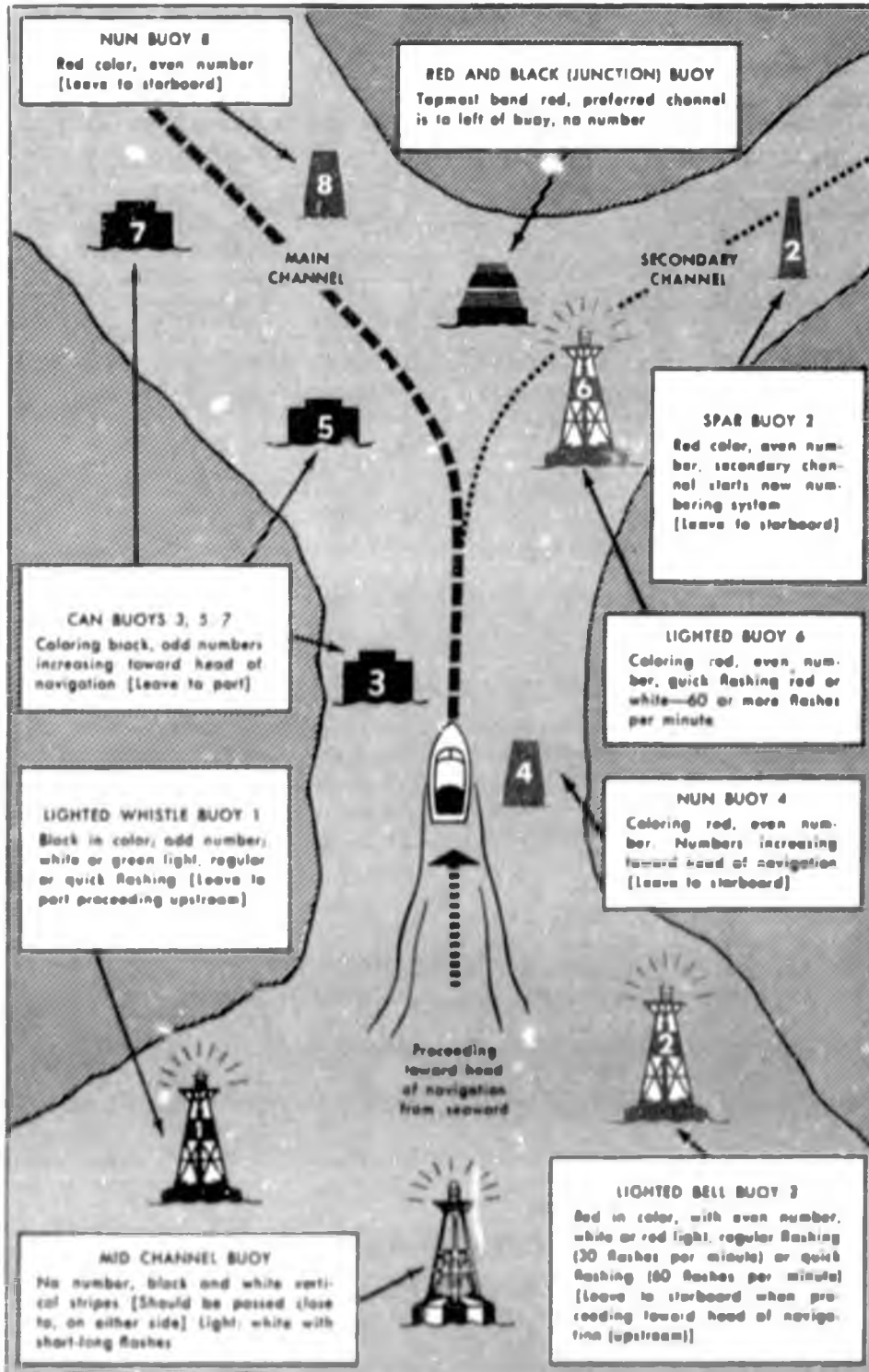

SAILOR'S WORKSHEET 5

1. Name four ways that navigational aids guide the boater.

2. What are four natural aids to navigation?

3. U.S. waters are marked with a _____

4. The red nun or red spar buoy should be on the _____ side when going upstream or entering a channel from a larger body of water.

5. The black can or black spar buoy should be on the _____ side when going upstream or entering a channel from a larger waterway.

6. Red nun or red spar buoys have _____ numbers.

7. Black can or black spar buoys have _____ numbers.

8. Identify the navigational aids:

A. _____

B. _____

C. _____



A.



B.



C.

9. Name five different kinds of navigational aids.

10. What are the three R's in boating and what do they mean?

The Compass

While not required by law for the private boater an accurate compass is probably one of the most important and interesting pieces of equipment on a boat. In its simplest form the compass is a needle that points to North.

Small boat compasses use a compass card instead of a needle. This is simply a round disk that sits on top of the magnetized needle or bar. Around the compass card on the frame of the compass are the degrees of the entire compass, 360 total.

Contrary to common belief, the compass card or the needle of the compass does NOT turn. It stands still and the boat along with the frame of the compass turns around it. Because of this you can look at the compass and see which direction you are going by reading the lubber line against the compass card. In a way, the compass card is like having a little world floating in front of you, and no matter how you change course it is constantly in the same position as the earth you are boating on.

Practice cruising by course, that is, draw a line across the chart (maps of water areas are properly called charts) from where you start to where you wish to go. Note the degrees of your course and hold that course with your compass until you reach your destination. Did you steer a straight line or did you have to change your heading often? With a little practice you'll find that steering a course with your compass will leave a straight wake behind your boat, proof that you're not zig zagging your way across the water.

To understand better how to use a compass, simply hold a boat compass in your hands, note the degrees by using the lubber line that is your course to a point across the room. Holding the compass steady, walk across the room. Holding your course steady. Now turn around and come back. If you do it properly you'll add or subtract exactly 180 degrees.

Practice finding the return course by adding or subtracting 180 degrees. Remember the answer always has to be LESS than 360 degrees. For example if your outbound course is 40 degrees, you can return to your starting point by cruising 220 degrees. Never confuse 030 with 300 degrees. Most compasses do not show the last zero, therefore, 3 on your compass indicates 30 degrees and the number 30 means 300.

Once you have your compass properly adjusted for your boat, keep metal objects, especially anything with a magnet like a flashlight, small radio or stereo speaker as far away as possible. Magnetized or large metal objects may turn your compass card from several feet away. Electric wiring is always suspect if it runs close to your compass. Be sure to check your compass by switching on and off all the electrical



switches. Snapping on the running lights could change your compass card by several degrees or make it fall completely. Digital wrist watches have been reported to change compass headings by as much as five degrees.

Nautical Charts

Most lakes and rivers have some kind of chart available to help the boater avoid danger areas and find his way from one point to another. Large bodies of water, bays, rivers, oceans and lakes have been charted by the National Ocean Survey.

NOS charts provide much detailed information about water depth, marker buoys, dangers under the water and over it, as well as an accurate picture of shorelines and waterways.

Estimating one's position on the water is always difficult because distance is deceiving over the water. The best rule for deciding where you are is to identify at least three landmarks or navigational aids in as much of a complete circle as possible. Compare their positions to the chart you are using.

Keeping an eye on only one point is a good way of going aground or running over rocks that are plainly marked on your chart. Learning to recognize the landmarks and navigational aids is a skill that only comes with practice.

WEATHER

Weather is uncertain and difficult for even a professional to predict. Always watch for signs of changing weather. Check reports and forecasts often.

While no rules are always true, here are a few guidelines to help determine weather changes.

Bad weather changes come from the west. This is usually true. A storm to the west will likely hit soon. It seldom passes by. Storms to the north or east may pass over. But, be prepared! There is also a good

chance of getting caught right in the middle of it.

Watch for wind shifts. This usually means weather is changing.

Check the barometer. Moving air creates pressure changes when it passes over the earth. A barometer registers air pressure. When pressure is heavy, the barometer has a high reading. A rising barometer indicates fair weather ahead. When pressure is high, clouds are high in the sky. Low clouds usually accompany low pressure.

CLOUD FORMATIONS

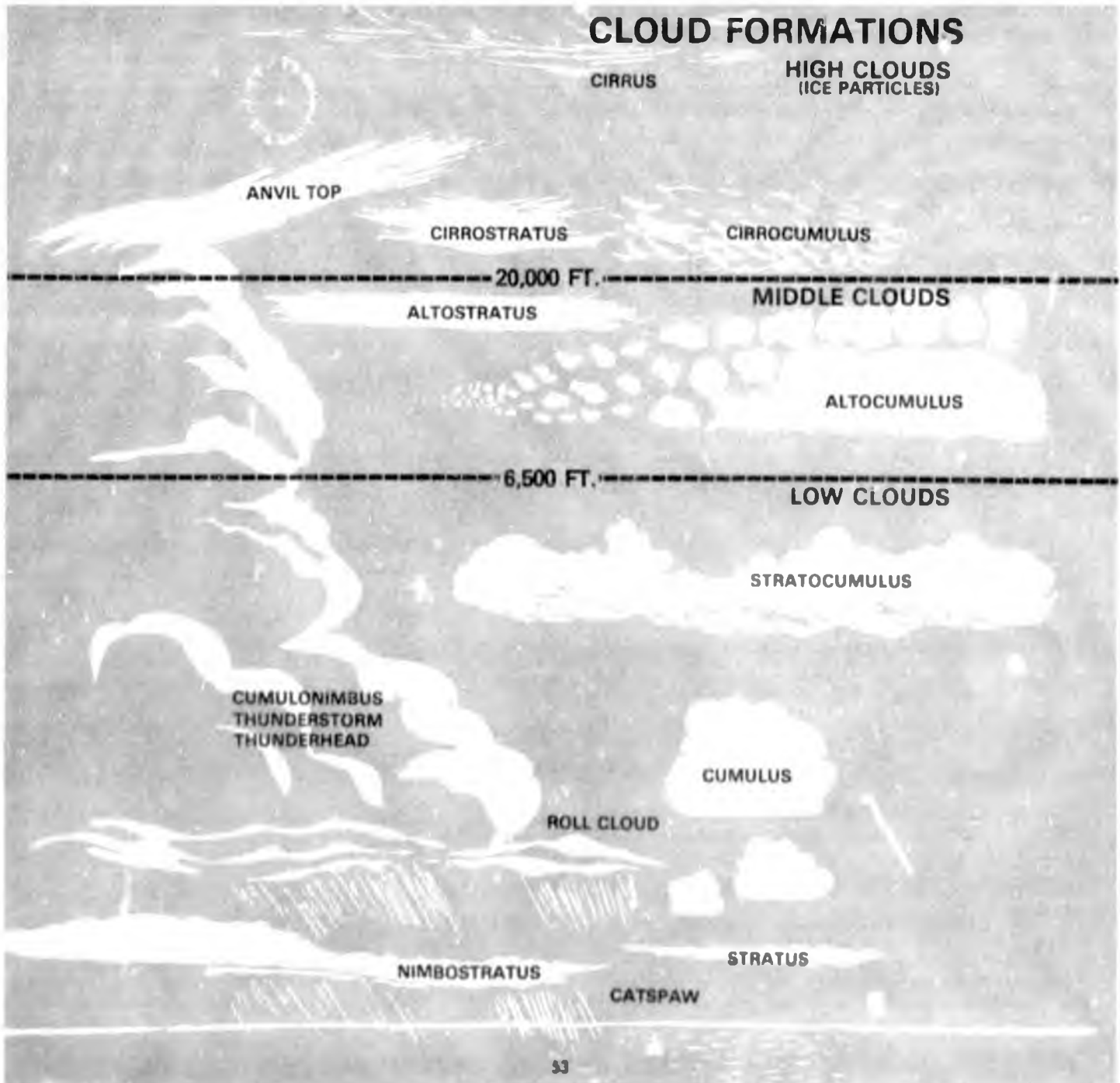

WEATHER

Winds and Currents

Winds and currents can greatly affect a motorboat's course. If a boat sits deep in the water, it will be influenced more by current than wind. Likewise, a high-riding boat will be affected more by wind than current. In plotting a course, take winds and currents into account. Before taking a motorboat into strong currents or winds, practice safe handling in calm waters.

Always allow *leeway* for current and wind. When underway, check navigational signs and aids frequently. If one has been missed, do not proceed. Turn back until the proper course is re-established. If lost, anchor and wait for help. Remember, always allow for leeway, which does not affect the compass, to stay on course.

A motorboat in a river or stream is best handled going against the current. Going down stream, the boat must go faster than the current. Otherwise, it cannot be steered. Never drift in strong currents. Current speed is changeable. In narrow channels, current speed increases. In wider channels, the current usually decreases.

Currents and winds can be very helpful to the boater. Learn to use them to advantage.

Tides

The movement of tides affect water speed and depth. Water depth may vary by 10 feet or more on tidal waters. A safe course at noon may be dangerous three hours later. Learn to read and understand tide tables.

Wind-barometer Table

Wind Direction	Barometer Reduced to Sea Level	Character of Weather
SW to NW	30.10 to 30.20, steady	Fair, with slight temperature changes for 1 or 2 days.
SW to NW	30.10 to 30.20, rising rapidly	Fair followed by rain within 2 days.
SW to NW	30.20 and above, stationary	Continued fair with no decided temperature change.
SW to NW	30.20 and above, falling slowly	Slowly rising temperature, fair for 2 days.
S to SE	30.10 to 30.20, falling slowly	Rain within 24 hours.
S to SE	30.10 to 30.20, falling rapidly	Wind increasing in force, with rain within 12 to 24 hrs.
SE to NE	30.10 to 30.20, falling slowly	Rain in 12 to 18 hours.
SE to NE	30.10 to 30.20, falling rapidly	Increasing wind and rain within 12 hours.
E to NE	30.10 and above, falling slowly	In summer, with light winds, rain may not fall for several days. In winter, rain in 24 hours.
E to NE	30.10 and above, falling fast	In summer, rain probably in 12 hours. In winter, rain or snow, with increasing winds, will often set in when the barometer begins to fall and the wind sets in NE.
SE to NE	30.00 or below, falling slowly	Rain will continue 1 or 2 days.
SE to NE	30.00 or below, falling rapidly	Rain with high wind, followed within 36 hours by clearing, and in winter, colder.
S to SW	30.00 or below, rising slowly	Clearing in a few hours, fair several days.
S to E	29.80 or below, falling rapidly	Severe storm imminent, followed in 24 hours by clearing, and in winter, colder.
E to N	29.80 or below, falling rapidly	Severe NE gale and heavy rain; in winter, heavy snow and a cold wave.
Going to W	29.80 or below, rising rapidly	Clearing and colder.

NOTE: The table includes general statements about the weather and can be very useful. However, the latest official Weather Bureau forecast should be used whenever the forecast is available. These forecasts are available on scheduled marine radioplane broadcasts, from commercial radio stations, and from the Weather Bureau offices.

WEATHER

Weather Signals

When potentially dangerous wind or sea conditions exist or are forecast, storm signals are displayed. These include small craft, gale, storm and hurricane warnings. Small craft warnings are directed to craft of many sizes and designs. Do not set out in storm warnings unless the boat can handle conditions forecast. Check with local weather stations, Coast Guard radio or Weather Bureau broadcasts (162.55 MegaHertz) for the latest weather forecast. Also check local weather and sea conditions.

When afloat, watch for these signs of dangerous weather ahead:

1. Dark, threatening clouds may indicate a squall or thunderstorm.
2. Watch for a steady increase in wind or sea. Pay special attention to increasing winds blowing against a strong tide. Steep waves may form, capable of capsizing a boat.
3. Heavy static on the AM radio may indicate thunderstorms nearby.
4. Always check radio weather broadcasts and warnings.

Fog can be a serious threat to the boater. It forms frequently in coastal waters, especially during summer. Fog may reduce visibility to only a few feet. Landmarks and navigational aids disappear. At first sign of fog, the boater should proceed to buoy. If practical, he should then return to harbor.

It is wise to record compass course and time between buoys upon departure and return to harbor. This easy reference may someday help avoid disaster.









Sea Anchor



Caught in Foul Weather

1. Reduce speed. Proceed with caution.
2. Head for nearest shore that is safe to approach. Stay in protected area until storm subsides if one is near.
3. Head bow into waves at slight angle. Watch for floating debris.
4. Secure loose items. Have emergency gear ready.
5. Keep bilges free of water.
6. Seat passengers on bottom of boat near center line. Put on life jackets.
7. If motor fails...drag sea anchor (tackle box, bucket or shirt with neck and sleeves knotted) from bow.

National Weather Service Storm Advisories

	SMALL CRAFT ADVISORY Winds up to 28 m.p.h.	GALE WARNING Winds 29 to 34 m.p.h.	STORM WARNING Winds 35 to 73 m.p.h.	HURRICANE WARNING Winds over 73 m.p.h.
DAY SIGNALS				
NIGHT SIGNALS				

SAILOR'S WORKSHEET 6

1. Though not required by law the _____ is one of the most important pieces of navigational equipment.

2. A road _____ is for highway use; a _____ is for navigational use.

3. A barometer registers _____

4. Low clouds usually accompany: (a) high (b) low pressure.

5. In addition to wind, a motorboat's course can be affected by _____

6. What is leeway?

7. Identify the following storm signals:

(a) _____

(b) _____

(c) _____

(d) _____



8. What is the first thing you should do if caught in foul weather?

9. You should _____ your boat into the waves if caught in bad weather.

10. What is a sea anchor?

11. Three articles which can be used as sea anchors in an emergency are:

12. Bad weather usually comes from the _____

Part IV



RULES of the ROAD

Understanding the Rules of the Road

A word of encouragement, you will not be expected to quote all the rules of the road. However, no matter where you do your boating, others have the right to assume that you know what you are doing. Remember, when you take the wheel or tiller, there is a presumption of knowledge! If you fail to observe the rules the fact that you did not know them will not be accepted as a valid defense.

Navigational skills, like driving skills, are meaningless without a set of basic rules of the road. These rules are often common sense guidelines. The reason for having rules is to prevent collision. They supply uniform patterns of passing, direction and safe operating behavior. They help prevent accidents.

(The Rules taught in this course are primarily Inland Rules of the Road. International Rules are similar, however, there are a few major differences, especially in sound signals, lights and shapes. For further information, refer to CG-169 Navigation Rules and CG-169-1 Colregs).

The determination of where Inland Rules begin and International Rules cease is at times difficult. A general rule is: "the waters inshore of a line approximately parallel with the general trend of the shore, drawn through the outermost buoy or other aid to navigation of any system of aids are inland waters". Many charts also show the location of these divisions. See CG-169-1 for further information in given areas.

Safety Tips and Regulations

1. Reckless or Careless Operation

Avoid causing harm or injury to any person, boat or property. Respect the property and rights of others on the water. No person should operate any vessel or manipulate any water skier, aquaplane or similar device in a reckless or negligent manner so as to endanger the life, limb or property of any person.

2. Operator Awareness

Always keep a sharp lookout for other boats, swimmers or obstacles. Never operate a boat while under the influence of alcohol or drugs.

3. Speed Regulations

When no limits are posted, operate the boat so it

will not endanger others. The boat must be able to stop safely within the clear distance ahead. When passing near marinas, fishing areas, swimming areas, boat servicing buoys or similar activities, reduce speed. Skippers are responsible for damage caused by wakes.

Every vessel shall, under conditions of reduced visibility, go at a moderate speed with careful regard for existing circumstances and conditions. Other actions such as speeding in confined or restricted areas, "buzzing" or "wetting down" others, skiing at prohibited times or in restricted areas, can also be construed to be reckless or negligent operation.

4. Restricted Areas

Some waterways limit boat or motor size use. Check federal regulations before departing. In some cases, a launching permit may be necessary.

5. Overloading

Consider weather and existing conditions. Never load a boat with passengers or cargo beyond its safe carrying capacity. For a guide, check the manufacturer's load capacity plate.

This plate is found inside the boat in full view of the operator's station. It gives maximum load and horsepower rating. It is mandatory on new boats, single hull vessels under 20 feet and can be helpful matching motor to boat.

U. S. COAST GUARD CAPACITY INFORMATION	
MAXIMUM HORSEPOWER	
MAXIMUM PERSONS CAPACITY (POUNDS)	
MAXIMUM WEIGHT CAPACITY (PERSONS, MOTOR & GEAR) (POUNDS)	
THIS BOAT COMPLIES WITH U. S. COAST GUARD SAFETY STANDARDS IN EFFECT ON THE DATE OF CERTIFICATION	
MANUFACTURER	HVCHOX BOAT CO.
MODEL	COLUMBIA, MICHIGAN
COMPLIANCE WITH THE FOLLOWING U. S. COAST GUARD REQUIREMENTS AND/OR BIA RECOMMENDATIONS IS VERIFIED	
LOAD AND HP CAPACITY	BASIC FLOTATION
NAVIGATION LIGHTS	SYSTEM
COMPARTMENT VENTILATION	
BOATING INDUSTRY ASSOCIATIONS	

Outboard Capacity Plate

RULES of the ROAD

6. Riding on Decks or Gunwales

Riding on the bow, gunwale or transom of a vessel propelled by machinery underway when such position is not protected by railing or other reasonable deterrent to falling overboard or riding in a position or manner which is obviously dangerous. (This does not apply to a vessel's crewmen in the act of anchoring, mooring or making fast to dock or another vessel or the necessary management of a sail.)

7. Interference with Navigation

Never obstruct a channel or fairway or interfere with the travel of other boats. Avoid anchoring in heavily traveled areas. Do not block launching areas.

8. Mooring to Buoys

The only buoys you are permitted to moor to are mooring buoys. Mooring to a navigation buoy or other aid to navigation is illegal.

9. Sewage Disposal

No person shall maintain or operate in or upon the navigable waters of any lake, reservoir or fresh water impoundment of this state any vessel which is equipped with a toilet unless such toilet is sealed or otherwise rendered inoperable or designed so that no human excreta can be discharged into such waters.

10. Water Skiing

Have at least two persons aboard a boat towing a waterskier; the operator and observer who must be 12 years of age or older. Skiing from sunset to sunrise is extremely dangerous.

Water skis and aquaplanes will not be operated in a manner to endanger safety of persons or property. Passing the towline over another vessel or skier or navigating between a vessel and its tow is also prohibited.

Although skiers are not required to wear Coast Guard approved life jackets, they are considered persons "on board". If an approved PFD is not worn by the skier, one must be on board.

Definitions

As we develop the subject, we will be using terms which may be unfamiliar or new. Because these rules are in fact laws, exact definitions become very important. The following terms will appear

throughout this Chapter, so let's "define our terms" before we proceed further.

Vessel - The word "vessel" includes every description of water craft, including nondisplacement craft and seaplanes, used or capable of being used as a means of transportation on water.

Motorboat - Any vessel propelled by machinery, including any sailing vessel under sail AND power.

Sailing Vessel - Any vessel which is under sail alone, including any power vessel under sail alone.

Underway - Not at anchor, aground or made fast to the shore.

Danger Zone - The area from dead ahead of a vessel to two points abaft the starboard beam.

Right-of-Way - The right and duty to maintain course and speed.

Stand-On [Privileged] Vessel - The vessel which has the right-of-way.

Give-Way [Burdened] Vessel - The vessel which must keep clear of the stand-on vessel.

Visible (when applied to lights) - Visible on a dark, clear night.

Short Blast (on whistle) - A blast of about one second duration.

Prolonged Blast (on whistle) - A blast of four to six seconds duration.

Long Blast - A blast of eight to twelve seconds duration.

Right of Way

On the water, the stand-on (privileged) vessel has the right-of-way. The give-way (burdened) vessel must give way. At night, running lights indicate which boat has the right-of-way. The lights give information about size, direction, speed and the way it is turning. A green light is on the starboard side of the boat; a red light on the port side. If a red light is visible, that boat is the stand-on vessel. The location of the white stern light helps tell what the other boat is doing. Always use common sense. This is especially important at night. The other boater may not know what the lights mean. Proceed slowly and with caution. If both boats obey the rules of the road, the maneuver is completed without danger and a collision is avoided.

Note: Under Inland, Great Lakes and Western Rivers rules of the road, signals are sounded for intention of movement. Under International rules of the road, the signals are only given when the movement is being executed.

RULES of the ROAD

The following diagrams indicate the proper, safe way to maneuver in several situations. These rules of the road are used on waters throughout the country. Learn them well.

Crossing Situation

Stand-on (Privileged) Vessel
...holds course and speed

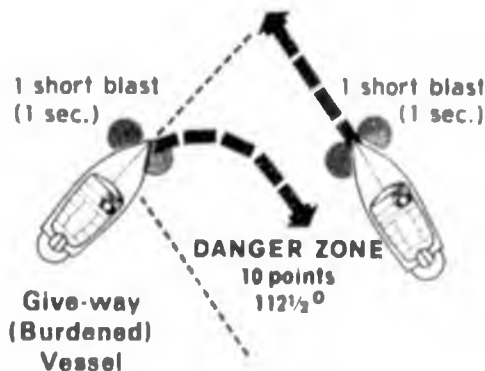

When two motorboats are approaching each other at right angles with risk of collision, the motorboat having the other boat on its port (left) side shall hold its course and speed and the other shall keep out of the way by directing its course to starboard (right) or if necessary, by slowing, stopping or reversing.

Meeting Situation

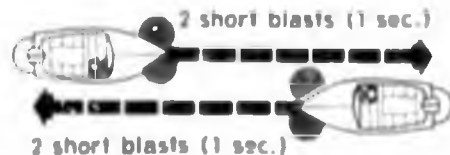

When meeting head-on, or nearly so, either vessel shall signal its intention with one short blast which the other vessel shall answer promptly. Each vessel shall then turn to its starboard (right) and pass with the other vessel on its port (left) side. When two powerboats are meeting head to head or nearly so, neither is the stand-on vessel.

When courses are so far to the starboard of each other as not to be considered as meeting head-on but risk of collision still exists, either vessel shall immediately give two short blasts which the other vessel shall answer promptly by two short blasts and each shall pass with the other vessel on its starboard.

OVERTAKING

Inland
"I want to pass you on your port side"
2 short blasts (1 sec.)
"Proceed"
2 short blasts (1 sec.)

International
"I intend to pass you on your port side"
2 prolonged blasts (0.6 sec.)
2 short blasts (1 sec.)
"Proceed"
1 prolonged, 1 short,
1 prolonged, 1 short

Stand-on (Privileged) Vessel Being Overtaken

Inland
"I want to pass you on your starboard side"
1 short blast (1 sec.)
"Proceed"
1 short blast (1 sec.)

International
"I intend to pass you on your starboard side"
2 prolonged blasts (0.6 sec.)
1 short blast (1 sec.)
"Proceed"
1 prolonged, 1 short,
1 prolonged, 1 short

Give-way (Burdened) Vessel Overtaking

When two motorboats are running in the same direction and the vessel astern desires to pass, it must give the sound signals indicated above.

If the course ahead is not safe for passing, the stand-on (privileged) vessel shall indicate so by four or more short rapid blasts under Inland rules or five or more short rapid blasts under International rules.

A motorboat approaching another motorboat from the stern and overtaking it shall keep out of the way of the overtaken vessel. The vessel being overtaken shall hold its course and speed.

RULES of the ROAD

Stand-on (Privileged) Vessel

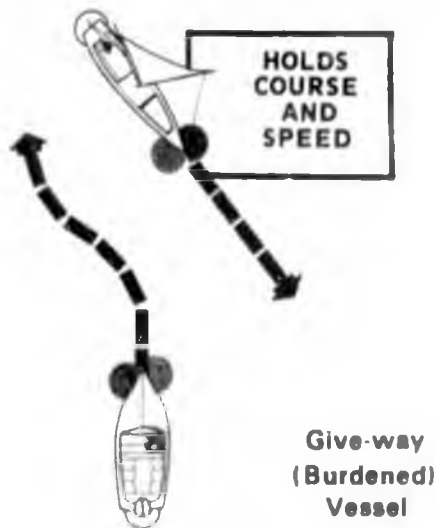

Sailboats, Other Vessels

A sailboat usually has right-of-way over motorboats—except when the sailboat is the overtaking boat or when it is under power. The motorboat then keeps clear and passes astern of the sailboat.

Boats propelled by oars or paddles have the right-of-way over motorboats. Small pleasure craft must yield to large vessels in narrow channels. Large craft cannot move as easily as small boats.

Other Situations

At any time when there is danger of collision and conditions prevent immediate compliance by either vessel with the other vessel's signals, the danger signal shall be sounded and both vessels shall be stopped or backed, if necessary, until signals for passing with safety are sounded and understood.

A motorboat nearing a bend in a channel where vessels approaching from the other direction cannot be seen, shall signal with long long blast (8 to 12 seconds) under Inland rules and with one prolonged blast (4 to 6 seconds) under International rules which should be answered with the same signal by any approaching motorboat within hearing.

Motorboats shall keep to the starboard side of narrow channels whenever safe and practicable.

Motorboats shall give and answer signals for passing when in sight of each other and passing or meeting within one-half mile. A vessel does not signal when another vessel is seen directly ahead crossing her course. Unnecessary use of sound signals

is prohibited. When boats are put in reverse, a signal of three short blasts will be made.

Traffic Hazards

Never water ski or cut in front of a tow. The pilot has a blind spot in front of the barges. He may not spot a fallen skier or a disabled boat.

Also stay away from the sides or back of the tow. Strong suction currents can draw a boat into the propellers. A dangerous current may also extend several hundred feet astern of the towboat.

It is important to avoid even moored barges. Currents can pull a boat underneath. Do not launch a boat upstream of a moored barge. A boat with a hard-to-start motor may drift down before the boater realizes the danger.

Fog Signals

The law prescribes signals to identify vessels under conditions of reduced visibility such as fog, mist, heavy rain or snow.

1. One prolonged¹ blast (4 to 6 seconds) every two minutes under International rules and every minute under Inland rules must be sounded by a motorboat underway and not towing.

2. One prolonged blast followed by two short blasts every two minutes under International rules and every minute under Inland rules must be sounded by a motorboat underway and towing another vessel. The vessel being towed must sound one prolonged and three short blasts every two minutes under International rules.

3. A sailboat underway must sound one prolonged blast followed by two short blasts every two minutes under International rules. Under Inland rules, a sailboat on a starboard tack must sound one blast every minute, two blasts every minute if on a port tack and three blasts in succession every minute if running free.

4. Bell ringing rapidly for about five seconds at intervals of one minute is the signal given by a vessel at anchor under both Inland and International rules.

A motorboat hearing a fog signal apparently forward of its beam shall stop engines and navigate with caution until danger of collision is over.

SAILOR'S WORKSHEET 7

1. The purpose of the Rules of the Road is to prevent _____
What should you do if no speed limits are posted?

3. Who is responsible for the damage caused by the wake of a boat?

4. The only kinds of buoys that may legally be used for mooring are _____ buoys.
5. What vessels must obey the Rules of the Road?

6. A boat with the right-of-way is called the _____ boat.
7. A boat which does not have the right-of-way is called the _____ boat.
8. In a crossing situation the boat to _____ has the right-of-way.
9. What must you do if your boat is being overtaken by another boat?



- a. Slow down.
- b. Speed up.
- c. Hold your course and speed.
- d. Turn to starboard.

Test continues on page 63.

SAILOR'S WORKSHEET 7

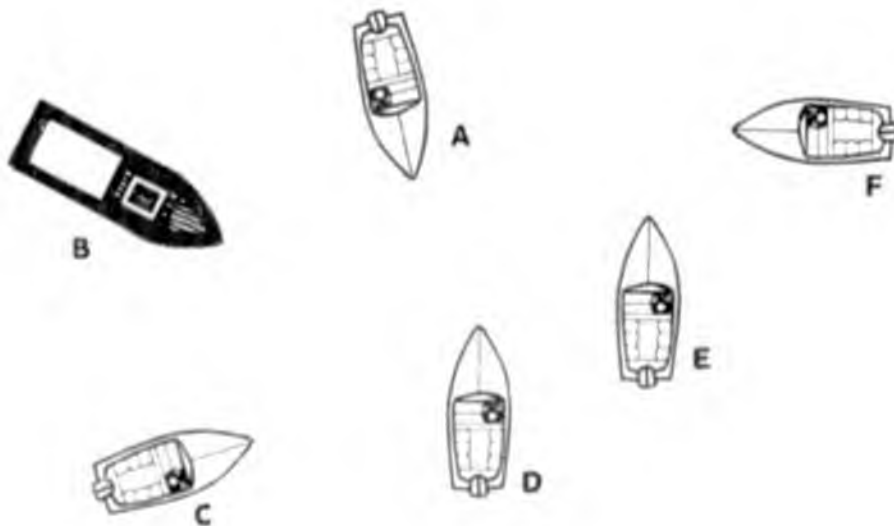

10. C and D are in _____ situation under Inland rules. C signals with one short blast. D answers by sounding _____ . (5 points each)
11. D and E are in a situation of _____ . _____ is the give-way (burdened) vessel _____ must maintain course and speed.
12. A and D are meeting _____ or nearly so. Both boats must _____ and pass each other on the _____ side.
13. Between E and F, _____ is the stand-on (privileged) vessel and _____ must turn to _____
14. If B is a large freighter in a narrow channel what must C and D do?

KNOTS

A line is a rope that is being used on board. A boater doesn't throw the rope. In nautical terms, he heaves a line.

Lines protect people and boats and when used with care, can last for many years. In tying knots, "practice makes perfect."

A boater uses six basic knots. Learn them well.

- | | |
|----------------|-----------------|
| 1. Square Knot | 4. Clove Hitch |
| 2. Bowline | 5. Figure Eight |
| 3. Anchor Bend | 6. Half Hitch |



Square Knot

Simple to make (so everyone says), the square knot is used for many applications for light duty work.



Bowline

Handiest of the knots, the bowline is probably the most difficult of those presented here. Use it whenever an eye or loop is needed. The bowline will neither slip nor jam.



Anchor Bend

The anchor bend is used to fasten a line to a ring or anchor. It is also called a fisherman's knot.



Clove Hitch and Half Hitch

The clove hitch is simply two loops with an end tucked under. This knot is used to secure the boat to a piling or similar structure for a short stay. For securing longer than thirty minutes, use two half hitches to lock the clove hitch.



Figure Eight

This knot is principally used as a stopping knot. It is placed at the end of a line to keep it from running through a block, jam cleat or other opening. The figure eight can also be used temporarily in place of "whipping" to prevent a line from unraveling.



How To Make Fast To A Cleat

The knot above, when finished, is a figure 8 with one loop reversed. Note that by snubbing the free end back under, the knot can be released without disturbing the boat. Most boaters take a half dozen figure 8's before locking with the reverse; two or three will do.

Here are some basic rules to keep lines strong and safe:

1. Keep them free from mud, dirt and grease.
2. Keep them coiled and stowed in a dry place. This helps prevent kinks and rot.

PREPARATION

When you prepare for your first cruise, remember that a boat is very unsafe if it is not loaded properly. Careful loading of supplies and equipment as well as the safety of passengers is the responsibility of the skipper.

Loading

When loading, stow all supplies securely, and well out of the way. Use a checklist to make sure all equipment is aboard, and always:

1. Keep deck areas clear.
2. Fasten gear to prevent shifting.
3. Distribute all weight evenly.
4. Never overload a vessel.



Loading

Boarding

When passengers are ready to board, the skipper should let them know which area of the boat they may or may not use. Assist them in putting on their PFD's. Make sure mooring lines remain secured to keep the boat steady while boarding.

When boarding a small boat from a dock or low pier, step aboard *amidship* (center of the boat). Stay low and hold onto the gunwales to keep your balance.

Don't carry equipment when boarding. Keep your hands free and have someone on the dock pass supplies to you after you are aboard.

If the boat is moored by bow lines or beached bow first, board over the bow. This will keep the craft stable.

When passengers are aboard, the skipper must make sure their weight is distributed evenly so the boat is *trim*. Total weight of the passengers, motor

and gear should not exceed Coast Guard or BIA capacity plate limitations.

(See page 58 for more information on the capacity rating plate.)

Heavy loads decrease a boat's *freeboard* (amount of space between the boat's rail and the waterline). If loaded too heavily, small waves or wakes may swamp the boat. Check your load before getting underway. Make sure the boat is not overloaded.

Passengers should remain seated at all times. If changing seats or standing is necessary, reduce speed to slow or stop completely. When moving, keep low and use the gunwales for balance.

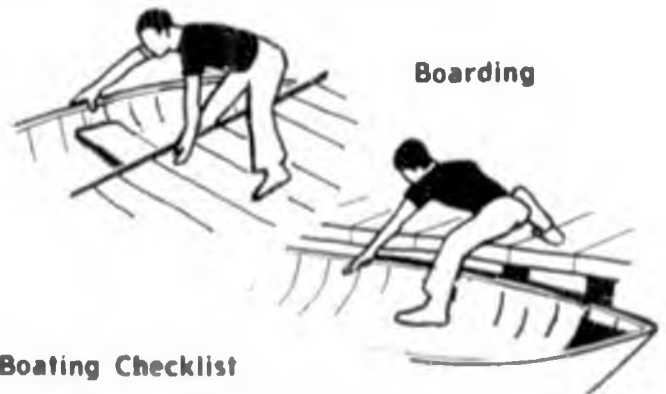

Boarding

Boating Checklist

Before casting off, the skipper should go over these final safety checks. Double checking and even triple checking is a good idea.

- 1. Safety equipment, including anchor and line and distress flag, aboard and accessible.
- 2. Coast Guard approved PFD for each person on board. (Plus one throwable device on vessels 16 ft. or over.)
- 3. Lines coiled and out of way.
- 4. Ample fuel in tanks.
- 5. Paddles or oars on board.
- 6. Lights and whistles in working order.
- 7. Heat doesn't leak.
- 8. Water is bailed.
- 9. Hinges clean, clear, free from gasoline vapors.
- 10. No fuel leaks.
- 11. Spilled gasoline wiped up.
- 12. Weather report OK for boating.
- 13. Gear fastened and out of way.
- 14. Passengers seated; boat trim.
- 15. Mooring lines snug.
- 16. Propeller clear of weeds, rocks, etc.
- 17. Motor safety chain attached to boat.
- 18. Motor shut off valve open.
- 19. Tool kit and extra parts on board.
- 20. Skipper is alert and sober, aware of local regulations...and in the right frame of mind.

THE FIRST CRUISE

With the equipment loaded and passengers aboard, the skipper is ready for the first cruise. Keep the mooring lines secured and start the engine in neutral. If using an outboard with starting cord, remember to stay seated. If operating an inboard, ventilate the engine compartment for at least five minutes before starting.

Be sure the area is clear before leaving the dock. Cast off lines, signal and pull away slowly. Coil lines and stow them out of the way.

On the first cruise, be sure to take along an experienced adult boater. Then practice making slow turns. Remember the stern moves in the direction it is pushed by the motor. Practice until you feel comfortable at the controls.

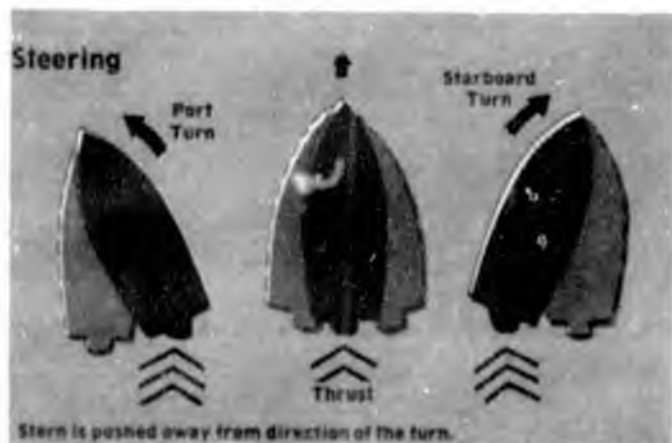

Leaving the Dock or Pier

Here are a few tips for casting off and leaving the dock.

With the wind or tide holding the boat to the dock:

1. Cast off stern line. Keep bow line secured.
2. Turn the motor or rudder to carry the stern away from the pier.
3. Shift into forward, go slowly ahead against the bow line.
4. After the stern swings away from the pier, shift to reverse to gain slack in the bow line. Cast off and back away from the dock until clear.
5. Shift to forward and leave the moorage at slow speed.

On the lee side of the dock:

1. Cast off lines.
2. Use an oar or paddle and push to keep the boat clear of dock.
3. Let the wind or current carry the boat out away from the dock.
4. Shift to forward and angle slowly away from the dock.

Once underway, pull in the fenders and make sure all lines are in and coiled. Travel at a slow no-wake speed until away from docks, floats, swimmers and other craft.

Skipper's Duties When Underway

After the boat is loaded and you've maneuvered out of the dock area, the skipper's responsibilities don't end. When underway, always:

1. Be thoroughly familiar with the way the boat handles. Know the distance it takes to stop after throttling down, the turning radius, most efficient cruising speed, etc.
2. Avoid taking any unnecessary risks that may endanger the crew or boat. Always choose the safest course.
3. Frequently check your position in relation to landmarks and aids to navigation. Know where you are at all times.
4. Note the weather, wind and current, if they are changing and how it is affecting the boat.
5. You now know the rules of the road, (page 58), be sure to follow them. In heavy traffic areas slow down and be extra cautious.
6. Always stop to render assistance to those in danger or distress. This means anything from a stalled engine to more serious situations.
7. In addition to the boat, the skipper is responsible for the passengers. Make sure they stay seated and act in a safe, responsible manner while aboard.

Cruising

An overnight cruise is a pleasant way to enjoy boating. There is adventure afloat, things to do and places to see.

First check the boat over carefully. Then chart a course. Stow extra parts and tools aboard. A portable radio is a must for weather reports. Compass, flashlights, drinking water, extra line, toilet articles, insect repellent, warm bedding and matches should all be aboard before setting out.

Be sure to allow plenty of time to reach your destination. Be familiar with the other ports along the way.

Keep a log. It's fun and gives you a record of your trip and everything that happened.

Use the motor wisely. Full speed ahead burns up extra gas and saves little time. On boats with planing hulls, get up to planing speed as soon as possible, then slow to about 70 percent power while staying on the plane. Conserve our energy resources.

MOORING

Docking

It is a good idea to practice docking in open water with an anchored float. Learn how the current and wind can move the boat from every direction.

When docking, head into the current and wind whenever possible. This gives better control of the boat. If the wind is stronger than the current, head into the wind.

When approaching a dock, move slowly. Have fenders in place and lines ready. Be ready to use forward, neutral and reverse gears. Ramming into a dock will damage both it and the boat. A good skipper doesn't bump any part of the craft. Ease the boat into the landing.

When close, toss lines to someone on the pier. If no one is available, pull the boat into the dock with a boat hook or your hand. Step ashore with the bow line. Secure this line first and then the stern line, if headed into the wind or current. Don't shut off the engine until all lines are fast.

When heaving or throwing lines make sure they are coiled. Heave them underhand for a smoother toss. Use enough line to allow for changes in water level and motion caused by rough water.

Learn how to dock in all possible weather conditions. Here are some basic guidelines for several different situations.

Without Wind or Current

When there is no wind or current, the skipper should approach the dock at a very slight angle (10 to 20 degrees). When the bow is close to the dock, shift the craft into reverse to slow headway. Then ease into the landing.



Into the Wind or Current

When the wind or current is coming from the bow, approach the dock at a slight angle (20 to 30 degrees). When the bow is close to the pier, turn the boat so it is parallel to the dock.

The stern will then swing into the landing. If necessary, shift into reverse to slow the boat.



With Wind or Current from the Dock

When the wind or current is coming from the direction of the pier, again approach slowly, this time at a fairly sharp (45 degree) angle. At the dock, shift into neutral and secure a bow line. Turn the rudder hard the direction away from the dock. Next slowly go forward against the bow line. This will cause the stern to move to the landing.



With Wind or Current toward the Dock

With the wind or current moving into the landing, approach so the boat is parallel to the dock. Shift into neutral and let the wind and current carry the craft into the pier. It may be necessary to do some steering.



With Wind or Current Astern

Docking with the wind and current coming from behind the boat is very difficult, and should be avoided if possible. If not, be ready to continually use reverse gear to slow momentum. Approach the dock at a slight angle. When the bow is close, use reverse to slow headway. Make fast the stern line first, then the bow line.

ANCHORING

Anchoring

At times the boater may wish to anchor to swim, eat, fish or just to relax. When anchoring, choose a spot with a level holding bottom, protection from the wind, and water of suitable depth. Such an anchorage is good for overnight and frees the skipper from worrying about the weather.

Anchor line 5 to 7 times water depth

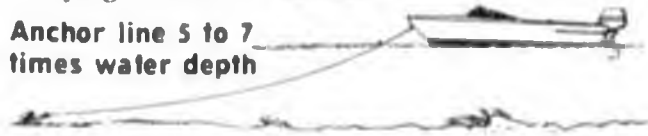

If mooring away from wharves or piers, allow enough clearance for a full circle swing of the boat and the swing of boats moored nearby. Don't depend on the current alone to keep the boat in line. Use an extra anchor with at least six times as much line as the depth of the water in which anchored. A long line cushions the shock of rough water and winds on the boat. It helps hold the anchor better. Be sure that all lines are tied fast and don't jam or slip.

Before thinking about how to anchor, decide where to anchor. The navigation chart can help find a good protected, flat bottomed spot to anchor.

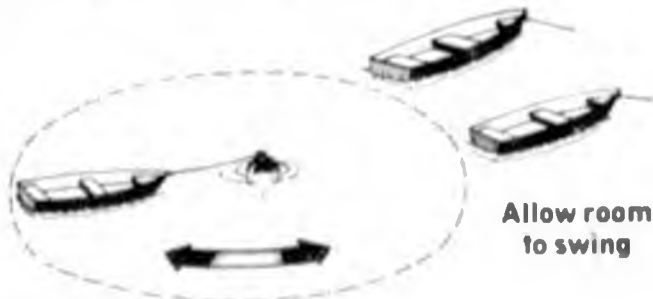

Allow room to swing

Types of Anchors



Northhill®



Danforth®

Northhill® and Danforth®

These popular lightweight anchors are among the most popular. They hold well on most bottoms, once set properly.

Move the bow slowly to the spot where the anchor will lie. Slow down, use reverse gear to control motion. Then lower the anchor over the side, hand over hand. Never stand in the coils of line on deck. Don't attempt to heave the anchor by casting from the side of the boat. Lower it as described above, then, the possibility of fouling the anchor is minimized.

With the anchor on the bottom and the boat slowly in reverse, line can be payed out as the boat takes it, preferably with a turn of line around the cleat. Stop the line when it is out about six times the depth of the water. The anchor will get a quick sure bite into the bottom. Shorten the line if needed, make line fast and shut off the motor.

After the boat is anchored, line it up with a landmark on the far shore. Then you'll be able to tell if it does begin to drift.

Types of Anchors

For many years, anchors were limited to relatively few types. The Navy® anchor was the most popular. Improved variations of each type appeared and radically new designs, based on holding power rather than weight evolved.

The Danforth® and the Northhill® are the most popular small boat anchors. The Danforth® is perhaps the most common type. This anchor has tremendous holding power for its weight. In the Danforth® anchor, the flukes are long and sharp. It is designed so heavy strains will bury the anchor completely.

To choose the right anchor, proportion the anchor weight to the boat length. A small anchor of 1/2 pound per foot, a medium anchor of 1 pound per foot and a large anchor of 2 pounds per foot.

Mushroom

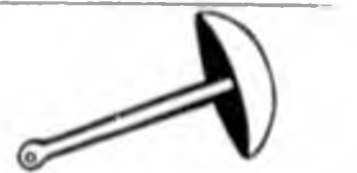

Mushroom

Often used for long-term moorage, this anchor works best in sand and mud.

Stockless or Navy®

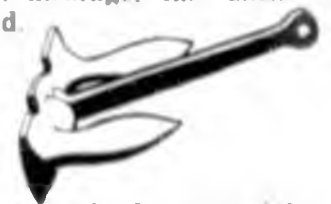

Stockless or Navy®

The Navy® anchor is a heavyweight. It uses weight for its holding power. It is used primarily on large vessels.

SAILOR'S WORKSHEET 8

1. When mooring a boat, it is best to hea _____ and the _____.
2. An anchor line should usually be _____ times the depth of the water anchored in.
3. An anchor should be: (a) thrown out (b) lowered over the side.
4. Name these five basic knots used in boating.



5. The figure eight knot is used primarily as a _____.
6. Line that is to be stowed should be in a dry _____ place.
7. The _____ is used for light duty work.
8. The _____ is used to tie a line temporarily to a pile or bollard.
9. The _____ is known as the handiest of knots.
10. A _____ would be used in securing a line over a cleat.



Part V



ACCIDENTS

An accident can happen whenever you're afloat. If another boat is in distress, offer aid. However, do not interfere with rescue operations by others with better knowledge or equipment.

Accidents usually occur without warning. Never stand up in a small boat when underway, fishing or starting the motor. It only leads to trouble. Remember, riding on decks or gunwales is unwise and in some states illegal. A quick stop or turn may toss a person overboard into the propeller. Always decrease speed gradually when stopping in a boat with a low transom. The wake may swamp the boat. Accidents are often caused because a basic safety rule has been ignored or broken. Common causes of boating accidents are:

1. Engine too big or too heavy
2. High speed turns
3. Overloading
4. Riding on decks or gunwales
5. Damage from wakes
6. Lack of Personal Flotation Devices
7. Explosion and fire during fueling or leakage

Small open boats capsizing cause more fatalities than any other boating accident. Some examples of these are fishing and hunting boats and whitewater rafts. Usual causes of capsizings are:

1. Taking the boat into waters beyond its capability of operating safely.
2. Overloading boat with passengers and equipment.
3. Inexperienced boaters operating in unsafe waters.

An overloaded boat loses buoyancy and stability. The boat then capsizes easily. Sometimes the wake of a passing boat or a passenger's sudden movement is enough to capsize an overloaded boat. **AN OVERLOADED BOAT IS A DANGEROUS BOAT.**

Should the boat capsize, grab a lifesaving device. Swim to the boat and hold on. Do not try to swim to shore. It is usually farther than it looks. And, it is easier to spot an overturned boat than a swimmer. As a general rule, wear a personal flotation device and stay with the boat until help comes.

Causes of Accidents



Engine Too Big or Too Heavy



High Speed Turns



Overloading

Damage from Wakes

Riding on Decks or Gunwales

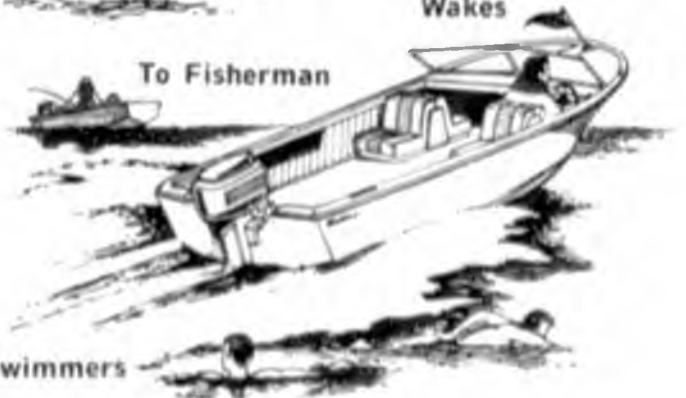

To Fisherman

To Swimmers

ACCIDENTS

Person Overboard

In the event of a person overboard, follow these procedures:

1. Swing stern away by turning the wheel toward the side the person went over.
2. Toss him a life saving device...even if he can swim. A life ring is the preferred device. It can be thrown farther and is easier to hang on to. However, use whatever device is nearest. Time is essential.
3. Slow the boat.
4. Keep the person in view. Other persons onboard should act as lookouts. At night, direct the best possible lights on the victim.
5. Try to approach the person from downwind or into the waves. Always use common sense and good judgement. Consider existing conditions, water temperature, physical condition and ability of the victim and what other help is available.
6. If someone aboard is capable, he may put on a life saving device with a line attached to the boat. He

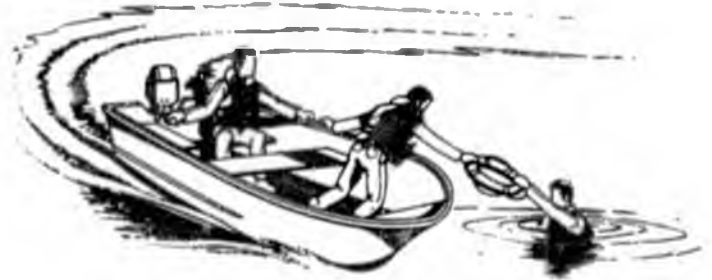

should then enter the water to assist the person needing help.

7. Assist the person in boarding the boat. It is difficult to climb into a boat from the water. If a person is hurt or cold, he may require help.
8. Depending on the size and construction of the boat, the person should be brought in over the bow or stern.
9. Always stop the motor when someone is going over the side or coming aboard.

Distress Signals

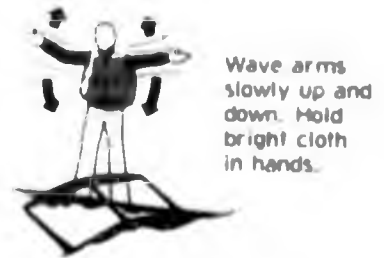
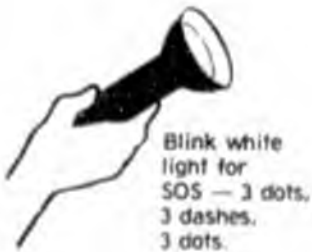

ACCIDENTS

Assistance and Rescue

When helping others, remember:

1. Always be ready to help if possible.
2. Help save lives, but never risk a life to save equipment.
3. Never take unnecessary chances. Use equipment to save lives.
4. Don't panic.

Get lifesaving devices ready. Approach the accident cautiously. Watch for people in the water. Toss lifesaving devices to those who do not have them. Give



help first to anyone who seems to be having trouble. Talk to the people in the water. They can tell you if they are all right.

To pick a person from the water, approach slowly and stop motor alongside. Heave a line and bring him in over the stern or bow. Balance the boat so it does



not roll too much when people crawl aboard. Do not overload the boat.

If there are more people requiring help than the boat will safely hold, bring aboard those most in need of help. Be sure all others have adequate life saving devices. Heave a line to the others and secure it to the stern cleat. This will allow them to be towed slowly to shore and will also prevent an overloading situation.

Survival in the Water

You may fall overboard or be forced into the water from a boat accident. Don't panic or fight the water. Swim slow and easy to conserve strength. Hang onto the boat unless it is in danger.

Any piece of equipment will help you float and signal for help. In a fire or explosion throw overboard anything that floats. Tie a rope to the boat and to the floating gear. If the boat is on fire you can then float a safe distance away and not lose the boat. Floating debris is easier to see than one person in the water.

Clothing can preserve body heat and help you float. Take it off only if it hampers movement. Fasten clothing around neck to hold in air. Keep arms under water. Hold air in trousers around the knees by bending legs. Hunters and fishermen can use air trapped in boots if they are kept underwater. You can also use clothing as a signaling device.

You may begin to lose body heat through hypothermia. (See page 79) If exhausted or losing consciousness, tie yourself to anything that floats.

Typical Search and Recovery Pattern

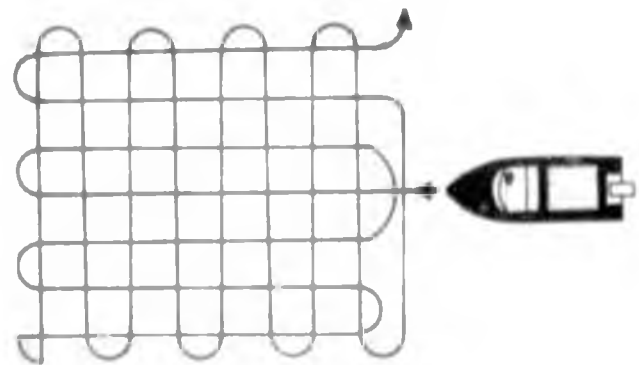

Accident Reporting

Boating accident reports help state and federal authorities reduce or eliminate future accidents.

Accidents include capsizing, collision, foundering, flooding, fire, explosion and disappearance of people or equipment other than by theft.

The operator of a boat involved in an accident is responsible for filing a report with the appropriate authorities. Reports are generally required for accidents that result in death or injury or in loss of damage over \$100. Know the requirements for your area.

SAILOR'S WORKSHEET 9

1. What are the seven most common causes of boating accidents?

2. An overloaded boat is a _____ boat.

3. If you see another boat in trouble you should _____.

4. If a boat is in trouble but is being aided by another boat better equipped than yours you should _____

5. What are some things you can do to help people who are in the water following a boating accident?

6. What is the first thing you should do if a person falls off your motorboat?

7. Number these statements in the order you would follow in the event of a person overboard from your motorboat.

- ___ Stop the motor.
- ___ Swing the stern away from the person overboard.
- ___ Bring the person aboard over the bow or the stern.
- ___ Throw the person a lifesaving device.
- ___ Slow the boat.
- ___ Approach the person slowly from downwind or into the waves.

8. How many of the 10 distress signals can you name?

9. Who is responsible for reporting a boating accident?

10. What are three reasons a boat capsizes?

11. If forced into the water from a boating accident, you should: (a) swim to nearest shore (b) stay with the boat unless it's in danger.

12. When in the water, clothing can preserve _____ and help prevent _____

FIRST AID

First Aid Courses

Learn as much about good boating and safety afloat as possible. Take an approved first aid course from the American Red Cross or other organization. Equip the boat with marine first aid kit. Include enough supplies to take care of nearly every kind of minor accident that might occur. Have information needed to use these supplies properly.

Remember — the first duty of a skipper is the safety of passengers, crew and boat.

Injuries

The most likely dangers are burns, serious bleeding, broken bones, drowning and shock.

Some first aid will be necessary while the injured person is being taken back to shore for professional help.

Shock

Shock can cause death if not treated promptly, even though the injury itself may not be serious enough to cause death. Any person with a serious injury should be treated for shock even though shock symptoms have not appeared.

Bleeding

Most bleeding can usually be controlled by applying a pad of clean cloth directly over the wound with elevation if injuries permit. For more serious bleeding, a large cloth should be applied and bandaged into place. Make sure it is not too tight.

If a limb is injured and the blood is bright red and spurting, pressure on the supplying arteries is needed. The pressure points are on the inner side of the arm midway between the shoulder and elbow and on the upper leg at the center of the angle where the leg joins the body. Direct pressure and elevation should also be continued.

Burns

A burn is a serious, painful injury and should be treated carefully. First aid objectives are to prevent infection, relieve pain and treat for shock.

There are three degrees of burns. First degree burns redden the skin, second degree burns form a blister, and third degree burns char or destroy tissues.

Broken Bones

If a person breaks a bone while aboard, keep the

INJURY	WATCH FOR THESE SIGNS	TREATMENT
Broken Bones	Pain, tenderness, deformity and possible bleeding.	Immobilize broken ends and adjacent ends. Control bleeding with direct pressure. Keep still and treat for shock.
Burns	Degrees 1st — Skin is red. 2nd — Skin is blistered. 3rd — Skin is charred.	Burned area should immediately be immersed in cold water. 70°F Add ice to cool water but do not apply to burned surface. Apply a cold pack to difficult areas. 3rd degree — apply a thick, dry, sterile dressing to keep air out.
Heart Failure Epilepsy	Victim is obviously ill with no apparent external injury. Clutching chest, convulsions.	Send for help immediately. Loosen collar, assist to a sitting or reclining position which ever makes breathing easier. Help with prescribed medicine. For convulsions do not restrain victim.
Objects in eyes, ears and nose.	Local irritation, tearing and wetting.	Eye: Don't rub. Lift particles out with corner of clean handkerchief. If unsuccessful or particle embedded, cover both eyes and get medical attention. Ear and nose: Get medical attention, don't try to remove.
Poisoning	Blurred vision, stomach cramps, vomiting, headaches, convulsions or deep sleep.	Get medical help immediately. If victim is conscious, dilute the poison by having them drink a glass of milk or water. DO INDUCE VOMITING. Contact a poison control center for further instructions.
Shock	Pale, clammy skin, irregular breathing, fast, weak pulse. Possible unconsciousness.	If breathing is regular and no chest injuries exist, raise hips and legs. If conscious and unobscured, give liquids, but never alcohol. Never force fluids on unconscious person. Keep victim comfortable.
Sunburn	Red, painful skin and chills. Fever and shock occasionally accompany severe sunburns.	Apply cold compress to sunburned area. Get medical help for severe sunburns. Prevention: Use sunscreen lotion before and during timed exposures to sun. Stop exposure when burn is first noticed.
Unconsciousness	Victim is not awake, does not respond to external stimuli.	Keep victim lying down. Cover to keep warm. Turn head to side in case of vomiting. Get medical attention. Stand by to give artificial respiration if breathing stops. Liquids or foods should never be given to an unconscious person.

FIRST AID

broken limb from moving. Stop the bleeding.

If a person in the water is suspected of having a broken back or neck, **Do Not Remove Him From The Water!** Keep head above surface and summon aid of a rescue service.

Carbon Monoxide Poisoning

Carbon monoxide gas is a by-product of gasoline engines. It may also be produced by catalytic heaters, charcoal, gas lanterns and gas stoves. Know the symptoms and how to treat them.

Carbon monoxide is odorless and tasteless. It is extremely toxic in small quantities. Symptoms are dizziness, ringing in the ears, headache, nausea, loss of motion and unconsciousness. To treat, get the victim in fresh air. If necessary apply mouth to mouth resuscitation and get medical help. Precautions against carbon monoxide poisoning are to keep lots of fresh air flowing through the boat, to zig-zag the course and to run faster than the wind. If you have a catalytic heater, be sure to have adequate ventilation. Do not leave the heater burning through the night.

Mouth to Mouth Resuscitation

Mouth to mouth resuscitation should be used for people who have stopped breathing because of: drowning, electric shock, foreign objects in the throat, head and chest injuries, heart attack, poisoning, shock, smoke suffocation, smothering and stroke.



A Person May Not Be Dead Just Because He Stops Breathing! A person who stops breathing might live if someone starts mouth to mouth resuscitation. The victim's lips, tongue and nails may have turned blue. This simply means he needs air. Start mouth to mouth resuscitation right away. This will give him air more efficiently than any other way known. It will not hurt him and it might save his life.

Mouth to mouth resuscitation means blowing air into a person through his mouth and then letting the air come out. Be sure his mouth is empty and his tongue hasn't slipped back in his throat. Breathe deeply, hold his nose shut and blow air in his mouth.

Watch for his chest to rise. When his chest rises, let the air come out of him. Repeat this cycle until he starts breathing on his own. If he should stop again, keep breathing for him. Blow 12 times a minute—about as often as you breathe yourself.

Don't waste time by moving him to shore or going for help. Clear the mouth of obstructions as soon as possible by delivering four sharp back blows with the heel of your hand over the victim's spine between the shoulder blades, placing your other hand on his chest to support him. Whenever possible, the victim's head should be lower than his chest to utilize the effect of gravity.

If he is pulled from the water, lay him on his back. Pull his shoulder up over your knee to raise his chest and start mouth to mouth resuscitation. Water may come out between breaths. **Getting Air Into His Lungs Is More Important Than Draining The Water.**

If the air won't go in, pull his lower jaw forward. Start blowing into his mouth with at least ten fast breaths. If air does not go in, his head may not be at the proper angle or there may still be something in his throat. Use your left thumb to hold his mouth open and reach in with your finger to pull out the object and to clear his throat.

1. Begin immediately
2. Place victim on back.
3. Clear mouth of foreign matter or any obstructions.
4. Tilt the head back gently to open the airway. Place one hand under the neck (behind the head) and the other on the forehead.
5. Pinch the nostrils closed, using the hand that is on the forehead.
6. Place your mouth over mouth of victim and blow.
7. First blowing effort should determine whether or not victim has any obstructions.
8. Remove your mouth and listen for the return rush of air that indicates air exchange.
9. If you are not getting air exchange, recheck head and jaw position and clear victim's mouth again.
10. You should be able to see victim's chest rise.
11. Normal rate: 12 per minute for adults, 20 shallow breaths for children.

If the above maneuver does not succeed, then try the Manual Thrust method:

FIRST AID



The Manual Thrust Method

1. Stand behind the victim and wrap your arms around their waist.
2. Place the thumb side of your fist against the victim's abdomen, slightly above the navel and below the xiphoid process (tip of the breastbone)

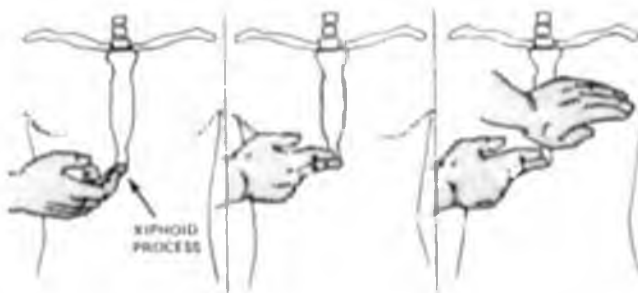

3. Grasp your fist with your other hand and press it into the victim's abdomen with a quick upward thrust.

4. Repeat the back blow and the manual thrust until they are effective or the victim becomes unconscious.

If the victim is unconscious, follow the above procedures, but add the Finger Probe:

Open the victim's mouth with one hand, insert the index finger of your other hand down the inside of the cheek and deep into the throat to the base of the tongue. Then use a hooking action to dislodge the

foreign body and maneuver it into the mouth so that it can be removed. Sometimes it is necessary to use the index finger to push the foreign body against the opposite side of the throat to dislodge and lift it. Be careful not to force the object deeper into the airway. If the foreign body comes within reach, grasp it and remove it.

After clearing the throat of any obstructions, put your mouth to his and breathe for him. If in the water, hold the person by locking your arm under his, tilt his head back as far as possible and begin.

If the victim is a child, hold him up by his ankles, with his head down, and slap hard between the shoulder blades to loosen the object. Then clear his throat and start mouth to mouth resuscitation again.

Hypothermia

The loss of body heat is probably the greatest hazard to the survival of a person in the water. The rate of body heat loss depends on water temperature, the protective clothing worn, physical condition, age, sex, and the manner in which the survivor conducts himself. (When a person swims, blood is forced through the large muscles of the upper body and it is cooled as it flows close to the skin surface. Upon return to the heart and deep body tissues, this cooled blood lowers the core temperature of the body.)

An abnormally low body core temperature can be recognized by a variety of symptoms. Very early during exposure, the body tries to combat the excessive heat loss both by constricting its surface blood vessels (to reduce heat transfer by blood to surface) and by shivering (to produce more body heat). However, if the exposure is severe, the body is unable to conserve or produce enough heat. Its core temperature begins to fall, creating a condition known as "hypothermia". As the body core temperature ap-

Hypothermia Chart

Water Temperature (F)	Exhaustion or Unconsciousness	Expected Time of Survival
32-6	under 15 min.	under 15-45 min.
32.5-40.0	15-30 min.	30-90 min.
40-60	30-60 min.	1-3 hr.
60-60	1-2 hr.	1-6 hr.
60-70	2-7 hr.	2-40 hr.
70-80	3-12 hr.	3 indefinitely
over 80	indefinitely	

NOTE: In the water temperature we find in Alaska, 35°-42°F, the symptoms of hypothermia occur very rapidly.

FIRST AID

proaches 95°F, it starts to fall more rapidly. As the temperature continues to fall, signs of pain, tiredness, poor coordination, numbness, poor speech and mental confusion appear. As the internal temperature decreases into the 80s, unconsciousness may result, as well as a bluishness of the skin, collapse of the veins in the skin, enlargement of the pupils, muscle stiffness, irregular heart rate and a weak, barely detectable pulse. Death may occur when the core temperature range is between 80° to 85°F but it is more likely to occur when the body core temperature drops below 80°F.

If you are involved in a boat casualty and are forced to abandon, your survival procedure should be preplanned.

1. Locate and wear a personal flotation device as quickly as possible. This is probably the single most important item of survival equipment, and it may increase a person's survival time (but unless assistance is available, death may occur ultimately due to loss of body heat. When a person is forced to exert energy to stay afloat, i.e., treading water, swimming, heat loss increases and survival time decreases).

2. Try to enter the water in a lifeboat or raft. By doing so, you will avoid wetting your insulation and losing your valuable body heat to the water.

3. Wear several layers of clothing. If you are fortunate enough to stay dry and enter the water in a lifeboat or raft, the trapped air within your layers of clothing will provide excellent insulation. (It has been shown that body areas that are wet can lose heat over 200 times faster than if the same area were dry and exposed to the same temperatures.) However, if you become wet in abandoning your boat, the layers of clothing, although wet will slow down the rate of body heat loss. Clothing having thickness such as waffle-weave underwear, wooleens and pile lined garments are excellent for building up layers. An ideal outer layer of clothing would be a waterproof or coated fabric windbreaker or foul weather garment. Should you be afloat in the water, a waterproof outer garment having close fitting wristlets, anklets and collar reduces the passage of water through those openings and helps to cut down body heat loss.

4. Protect your head, neck, groin and the sides of your chest; for these are areas of rapid heat loss to cold water. In addition, waterproof or water-repellent insulation gloves or mittens with a snug fit at the wrists reduce the water exchange at the hands,

preserve body heat and prolong the usefulness of the hands in performing helpful maneuvers. Insulated boots and layers of socks impact the same protection to the feet. A great deal of body heat can also be conserved by covering the head with an effective hood (An unprotected head could lose up to 1/3 of the body's total heat production at 40°F, up to 3/4 at 5°F. This loss is even greater at lower temperatures, especially when the head is wet). Useful head covers include woolen hats, foam rubber scuba-type hoods, ski-hats or foul weather hoods. The neck can be protected with a towel, scarf or other cover.

5. You must enter the water directly, try to minimize the shock of sudden cold immersion. A sudden plunge into the cold water can cause rapid death or an uncontrollable rise in breathing rate resulting in an intake of water into the lungs. If jumping is necessary, try to hold your breath, pinch your nose and, in general, avoid swallowing water during the plunge.

6. Once in the water, orient yourself and try to locate the boat, lifeboats, liferafts or other floating objects. If you were unable to prepare yourself, button up now as much as possible. In cold water you may experience violent shivering and great pain in the limbs. These are natural body reflexes that are not dangerous.

7. While afloat in the water, do not attempt to swim unless it is to reach a nearby craft, a fellow survivor or a floating object on which you can lean or climb (but remember, distances on water are deceptive, your goal may appear closer than it actually is). Unnecessary swimming motion will "pump" out the warmed water between your body and the clothing layers and increase the rate of body heat loss. In addition, unnecessary movements of your arms and legs send warm blood from your body's inner core to its cold outer layer. This results in a very rapid heat loss. Remain as still as possible in the water, however painful it may be. Remember pain will not kill you but heat loss will.

8. The body position you assume in the water is very important in conserving your body heat. Tests show that the best body position is the HELP position (Heat Escape Lessening Position) wherein you hold your knees up to your chest in a "doubled up" fashion with your arms tight against the side of your chest. This position minimizes the exposure to the cold water of your groin and chest sides, both areas of high heat loss. Try to keep your head and neck out of the water.

FIRST AID

Another heat conserving position is to huddle closely to one or two others afloat, making as much body contact as possible.

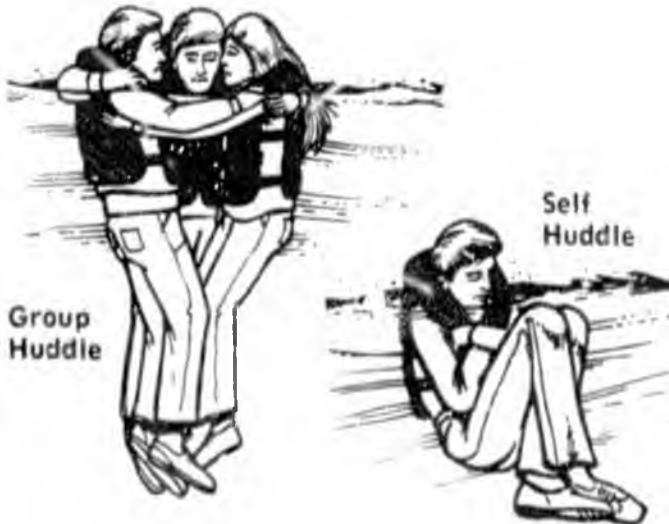

The HELP Position

9. Try to board a lifeboat, raft or other floating platform or object as soon as possible. Remember, you lose body heat about 25 times faster in water than in air. Since the effectiveness of your insulation has been seriously reduced by water soaking, you must now try to shield yourself from wind to avoid a wind-chill effect. If you manage to climb aboard a lifeboat, shielding can be accomplished with the aid of a canvas cover or tarpaulin or an unused garment. Huddling close to the other occupants of the lifeboat or raft will also conserve body heat.

10. Keep a positive attitude about your survival and rescue. This will improve your chances of extending your survival time until rescue comes. Your will-to-live does make a difference.

The treatment of hypothermia will of course depend on both the condition of the survivor and the facilities available. Generally speaking, survivors who are rational and capable of recounting their experiences, although shivering dramatically, merely require removal of all wet clothes and replacement with dry clothes or blankets. Hot sweet drinks and rest in a warm environment are also recommended.

In more serious cases, where the victim is semiconscious, unconscious or apparently dead, contact should be made immediately with a ship or shore medical facility. While awaiting medical in-

structions, administer the following first aid care to the survivor immediately:

1. After removing the victim from the cold water, gently transfer him to a warm environment.
2. Remove his clothes only if it can be done with a minimum of movement of the victim's body. Do not massage him.
3. Lay the unconscious or semiconscious victim in a face up and slightly head down position, unless vomiting occurs.
4. If available, administer warm, humidified oxygen by face mask. The oxygen will not only assist victims if they are having difficulty breathing or have a low respiratory rate but it will also provide core re-warming. Of course, mouth-to-mouth resuscitation is always advisable if the victim is having problems breathing and no other form of assistance is available.

5. Begin to rewarm the victim actively. Do not delay! Even conscious hypothermia victims have died following apparently successful rescues because rewarming attempts were delayed or were inadequate. Any of the following warming methods are recommended preferably in the order given:

- a. Place the survivor in a bath of stirred hot water at a temperature of 105°-110°F or a temperature in which an observer can comfortably leave his arm. Keep the arms and legs out of the bath, to delay the return of blood circulation to the extremities.
- b. Apply hot, wet towels or blankets at 115°F to the victim's head, neck, groin, chest and abdomen. Again, do not attempt to warm his arms and legs.
- c. Apply your own body warmth by direct body-to-body contact with the victim. A blanket should then be wrapped around you and the victim to conserve the heat you are supplying. Just wrapping a hypothermia victim in a blanket without a heat source is ineffective because he is not generating sufficient heat to rewarm himself.

6. In no case should the victim be given alcohol. Alcohol dilates the "peripheral" blood vessels and also depresses mental ability. A person who drinks to increase their survival time will probably die happier, but sooner.

7. Unconscious victims should be given nothing to eat or drink.

Cold Water Drowning

Every year approximately 75 people drown in Alaska making drowning the second leading cause of

FIRST AID

accidental death. This statistic is made even more tragic because many of those deaths may have been avoided. Recent medical research has indicated that victims, who in the past have been considered beyond help, may be saved despite long submergence and the absence of any sign of life. This is particularly true if the water is cold (as it is in Alaska) and the victim is young.

Sudden face contact with cold water (below 70 degrees F) sometimes touches off a primitive response called the "mammalian diving reflex". This complex series of body responses shuts off blood circulation to most parts of the body except the heart, lungs and brain. Thus, what little oxygen remains in the blood gets transported to the brain where it is needed the most. Even though there may be very little oxygen in the blood, it can be enough since the cooled brain requires much less oxygen than normal.

Procedures for revival of drowning victims are similar to regular hypothermia procedures; however, there are several important differences. These procedures follow:

1. Clear the air passage and begin mouth to mouth rescue breathing and external heart massage (CPR) IMMEDIATELY. DO NOT worry about getting water out of the victim's lungs...the body will absorb it quickly.

2. Prevent the victim from losing more body heat, but DO NOT rewarm the victim. Improper rewarming may harm the victim.

3. Get the victim to the nearest medical facility QUICKLY. CPR must be continued uninterrupted until the victim is under the care of competent medical personnel.

4. Do not give up. DROWNING VICTIMS LOOK DEAD. Their skin is blue and cold to the touch. There is no detectable heart beat or breathing. The eyes are fixed and dilated, and there is no other sign of life. However, if the water was cold there is still a good chance of survival.

5. Children and young people are the most frequent drowning victims. However, they are also good candidates for resuscitation since they have a more pronounced "Diving Reflex". In research at the University of Michigan Hospital, two thirds of the cold water drowning victims that were successfully resuscitated were 3 1/2 years old and younger. The colder the water and the younger the victim, the better the chance for survival.

Mouth to mouth resuscitation should begin immediately.

Wind Chill Factor

As we have noted, your body is continually producing and losing heat. Wind increases heat loss by reducing the thin layer of warm air next to your skin. This heat loss increases as wind speed increases. When air temperature is below freezing and the wind takes away heat faster than your body can replace it, you get frostbite. The danger of frostbite to exposed skin increases as the air temperature goes down or the wind speed goes up. The combined effect of wind and temperature is expressed in the wind chill chart as an equivalent temperature. This expresses the effective temperature acting upon exposed flesh.

Any movement of air past your body, such as that produced by walking, running, skiing or riding in an open vehicle, has the same cooling effect as wind. You should consider this in addition to natural wind when you use the windchill chart.

Any clothing or material which reduces or stops the effect of wind will give protection to the area covered but don't try to estimate this protection when you use the windchill chart. Of course wet clothing or footgear has a much reduced insulating value and will result in body heat loss nearly equal to that of exposed flesh.

Here's how you use the chart: find the estimated or actual wind speed in the left-hand column, and the actual temperature in degrees F across the top. Come across and down. The intersection on the chart is the equivalent temperature — the effective temperature acting upon exposed flesh. Precautions should be taken accordingly.

Estimated Wind Speed in MPH		Actual Thermometer Reading (F)										
		60	40	20	10	0	10	20	30	40	50	60
Calm		60	40	20	10	0	10	20	30	40	50	60
5	60	37	27	16	6	6	16	26	36	47	57	66
10	40	28	16	4	0	21	30	39	48	57	66	75
15	20	22	9	1	16	26	36	46	56	67	77	86
20	10	16	4	10	20	30	40	50	60	70	80	90
25	0	10	0	10	20	30	40	50	60	70	80	90
30	0	10	0	10	20	30	40	50	60	70	80	90
35	0	10	0	10	20	30	40	50	60	70	80	90
40	0	10	0	10	20	30	40	50	60	70	80	90
45	0	10	0	10	20	30	40	50	60	70	80	90
50	0	10	0	10	20	30	40	50	60	70	80	90
55	0	10	0	10	20	30	40	50	60	70	80	90
60	0	10	0	10	20	30	40	50	60	70	80	90

Wind speeds greater than 60 mph have little additional effect.

LITTLE DANGER

INCREASING DANGER

GREAT DANGER

DANGER FROM PROTECT OF EXPOSED FLESH

SAILOR'S WORKSHEET IO

1. All boats should have a marine _____ kit on board.
2. First aid courses are offered by the American _____.
3. Blowing air into a person through his mouth or nose and then letting the air come out is called _____ resuscitation.
4. Applying a pad of clean cloth directly over a wound is one method of stopping _____.
5. Symptoms of dizziness, ringing in ears, headache, nausea and unconsciousness indicate _____ poisoning.
6. Hypothermia is the _____

7. Pretend you have the following emergencies on board your boat. Read the list of injuries and write the letter indicating the right treatment in the space provided.

INJURY		TREATMENT
_____ Unconsciousness	A.	Immobilize broken ends and adjacent joints. Control bleeding with direct pressure. Keep still and treat for shock.
_____ Sunburn	B.	Burned area should immediately be immersed in cold water. 70° Add ice to cool water but do not apply to burned surface. Apply a cold pack to difficult areas. 3rd degree — apply a thick, dry, sterile dressing to keep air out.
_____ Poisoning	C.	Send for help immediately. Loosen collar. Assist to a sitting or reclining position which ever makes breathing easier. Help with prescribed medicine. For convulsions do not restrain victim.
_____ Shock	D.	Eye: Don't rub. Lift particles out with corner of clean handkerchief. If unsuccessful or particle embedded, cover both eyes and get medical attention. Ear and nose: Get medical attention, don't try to remove.
_____ Broken Bones	E.	Get medical attention immediately. Check for antidote on poison container. If none available, have person drink lots of water or milk. Do not induce vomiting. Contact poison control center immediately for further instructions.
_____ Burns	F.	If breathing is regular and no chest injuries exist, raise hips and legs. If conscious and unnauseated, give liquids, but never alcohol. Never force fluids on unconscious person. Keep victim comfortable.
_____ Objects in Eyes	G.	Apply cold compress to sunburned area. Get medical help for severe sunburns. Prevention: Use sunscreen lotion before and during timed exposures to sun. Stop exposure when burn is first noticed.
_____ Heart Failure	H.	Keep victim lying down. Cover to keep warm. Turn head to side in case of vomiting. Get medical attention. Stand by to give artificial respiration if breathing stops. Liquids or foods should never be given to an unconscious person.

GLOSSARY

Can you find all 112 nautical terms hidden in the puzzle?

Words can be found across, down and diagonally on the page. Some terms are easy. If you can't find them all, look in the glossary for words marked with a square.

- **Abaft** — Toward the stern
- **Abeam** — Amidship, at a right angle to the keel.
- **Aboard** — On, in or into a boat.
- **Afloat** — On the water.
- **Aft** — Describing the after section of a vessel, or things to the rear of amidship and near the stern.
- **Aground** — Touching bottom.
Ahead—Forward on a line with the boat's keel.
Alee—To the leeward side.
- **Amidship** — Describing the mid-section of a vessel, either with reference to length or width.
- **Anchor** — A forging or casting shaped to grip the sea bottom and, by means of a cable or rope, hold a boat in a desired position.
- **Astern** — Toward the stern. An object that is aft of a boat is said to be *astern of the boat*.
- **Athwart** — Across.
Athwartship—At right angle to the boat's keel.
Awash—At the level of the water.
- **Aye**—Yes while aboard a boat or ship.
- **Bail**—To remove water from a boat.
Come About—To change course or tack in a sailboat.
- **Ballast** — Heavy material such as iron, lead or stone placed in the bottom of the hold to keep a vessel steady.
- **Battens** — Thin strips of wood, plastic or other material set in pockets and sewed into the sail to hold or improve the set of a sail. On some racing boats the battens extend from leech to mast.
- **Beacon** — A post or buoy placed over a shoal or bank to warn vessels, also a signal mark on land.
- **Beam** — Imaginary line amidship at right angles to keel of vessel. Also vessel's width amidship.
- **Bearing** — The direction or point of the compass in which an object is seen.
Bight—A loop in any part of a line except the end, also a cove.
- **Delay** — To make fast to a cleat or belaying pin, also to cancel an order.
- **Below** — Beneath or under the deck. *One goes below* when going down into the cabin.
- **Bend** — To fasten by means of a bend or knot.
- **Bilge** — The lower internal part of a boat's hull, adjacent to the keelson.
- **Block** — A device with sheaves or pulleys through which the direction of a sheet or line can be controlled and by which extra leverage can be obtained.
- **Bollard** — A strong post for holding lines fast.
- **Boom** — A spar used to extend the foot of the sail.
- **Bow** — The forward part or front of the boat.
Bridle—A span of line with the ends secured and another line secured at its center for towing or lifting.
Bulkhead — Vertical partition in a boat

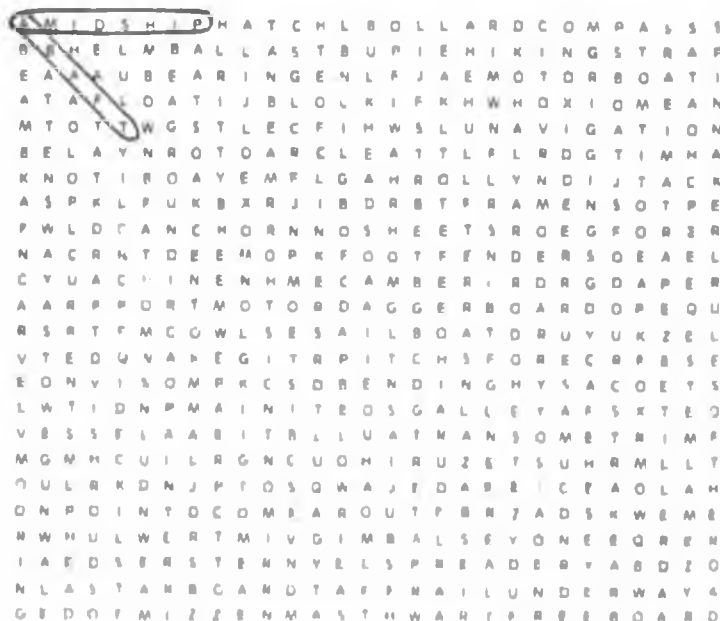

- Buoy — A floating, anchored navigational aid.
- Burdened Vessel — One which must stay clear of vessels having right-of-way. The give-way vessel.
- **Caulking; Calking** — Forcing a quantity of filler material into the seams of the planks in a boat's deck or hull to make them watertight.
- Camber — The arch of a deck, sloping downward from the center toward the sides.
- Capacity Plate — Must be in full view of the operator's station. Gives maximum weight capacity and horsepower rating.
- **Capsize** — To turn over.
- Carburetor Backfire Flame Attenuator — Required equipment on all motorboats except outboards and diesels. Reduces chance of backfire in internal combustion engines.
- **Cardinal Points** — The four main points of a compass.
- **Carvel** — A system of planking in which the outside planking of a boat is flush. The edges meet, giving the sheath a smooth surface.
- Cast Off — To let go or untie a line.
- Catamaran — Sailboat with two narrow hulls connected by a deck, plus two rudders.
- **Centerboard** — A pivoting board or metal plate, housed in a slotted trunk, which can be raised or lowered. When lowered it reduces a sailboat's tendency to sideslip when tacking.
- **Chart** — A map of a body of water that contains necessary piloting information.
- **Chine** — The intersection of sides and bottom of flat

- or V-bottom boats.
- **Cleat** — A piece of wood or metal with projecting ends to which lines are made fast.
 - **Clew** — The rear lower corner of a sail.
 - **Clinker** — A method of planking in which the lower edge of each strake overlaps the upper edge of the strake next below. (also called lapstrake.)
 - **Cockpit** — A well or sunken space in the afterdeck of a small boat for the use of the helmsman and crew. Forward cockpits are common in motor cruisers.
 - **Come About** — To change course or tack in a sailboat.
 - **Compass** — The instrument which shows the course of a vessel.
 - **Course** — The point of the compass toward which the boat is being steered.
 - **Cowls** — Hooded openings used for ventilation.
 - **Current** — The movement of the water in a horizontal direction.
 - **Daggerboard** — A vertical sliding centerboard on a sailboat.
 - **Dead Ahead** — Directly forward of a boat, on a line extending from the keel.
 - **Deck** — Any permanent covering over a compartment, hull or any part thereof.
 - **Dinghy** — A small open boat.
 - **Displacement Hull** — Type of hull that plows through the water even when more power is added.
 - **Documented Vessel** — Vessel registered with the U.S. Coast Guard.
 - **Draft** — The depth of the vessel below the water line, measured vertically to the lowest part of the hull.
 - **Drift** — The amount a boat is pushed off course by the current.
 - **Dry Rot** — A fungus decay which causes wood to become brittle and to fall apart.
 - **Ease Off** — To slack off.
 - **Ebb** — The reflex of the tide.
 - **Estuary** — An inlet or arm of the sea.
 - **Fathom** — Six feet.
 - **Fend Off** — To hold off when making a landing or coming along side.
 - **Fenders** — Objects placed along the side of the boat to protect the hull from chafing.
 - **Flare** — The outward spread of the boat's sides from the waterline to the rail at the bow.
 - **Foot** — The lower edge of a sail.
 - **Fore** — Used to distinguish the forward part of a boat or things forward of amidships.
 - **Forward** — Toward the bow.
 - **Frame** — Ribs of the hull, extending from the keel to the highest continuous deck.
 - **Freeboard** — Vertical distance measured on a boat's side amidships from the waterline to the gunwale.
 - **Galley** — The kitchen area of a boat.
 - **Gimbals** — The brass ring in which a compass sets to keep it level.
 - **Give-Way [Burdened] Vessel** — One which must stay clear of vessels having the right-of-way.
 - **Gunwale** — The upper edge of a boat's side. (Pronounced gun-nel.)
 - **Halyard** — A wire and/or line used to hoist and lower a sail or the line to hoist a flag or signal.
 - **Hatch** — An opening in a boat's deck to allow persons or cargo to go below.
 - **Head** — A marine toilet.
 - **Headway** — moving ahead or speed through the water.
 - **Heave** — To throw.
 - **Heel** — To lean or tip but not capsize.
 - **Helm** — The wheel or tiller by which a ship is steered.
 - **Hiking Strap** — A strap attached to floorboards or a centerboard trunk under which a crewman can hook his foot allowing him to hike his body out over the side of the boat.
 - **Hull** — The body of a boat.
 - **Hypothermia** — A physical condition when the body loses heat faster than it can produce it.
 - **Inboard** — Toward the center of the boat.
 - **Jib** — A triangular sail set on a stay, forward. A genoa jib is larger in size and is used for more speed.
 - **Jibe** — To tack before the wind in a sailboat.
 - **Keel** — A permanently positioned, principal fore-and-aft backbone member of a boat's hull used for stability and/or ballast.
 - **Knot** — To bend a line. Also, a unit of speed equal to one nautical mile (6,076.10 feet) an hour.
 - **Lee** — The opposite side from which the wind blows.
 - **Leech** — The after edge of a fore-and-aft sail.
 - **Leeward** — Situated on the side turned away from the wind. (Opposite of windward.)
 - **Leeway** — The amount a boat is carried leeward by the wind's force.
 - **Line** — Rope that is aboard or around a boat.
 - **List** — Leaning or inclining of vessel toward the side.
 - **Log** — A record or diary of a vessel's journey.
 - **Lubber Line** — A mark or permanent line on a compass that shows the center line of the boat.
 - **Luff** — The forward edge of a fore-and-aft sail. Also to cause the sail to flutter.
 - **Main** — The principal mast and sail.
 - **Mainsail** — The largest sail hoisted on the mast.
 - **Mast** — A spar set upright to support rigging and sails.
 - **Mizzen Mast** — The aftermost mast of a ship.
 - **Mooring** — Commonly, the anchor, chain, buoy, pennant, etcetera by which a boat is permanently anchored in one location.
 - **Mooring Buoy** — A buoy you may legally moor to instead of an anchor.
 - **Motorboat** — Any watercraft propelled by machinery, whether or not such machinery is the principal source of propulsion. For numbering purposes, the term shall not include a vessel which has a valid marine document issued by the U.S. Coast Guard or any federal agency successor thereto.

- **Navigation**—Directing a ship from port to port.
- **Nun Buoy** — A conical red buoy bearing an even number and marking the starboard side of a channel from seaward.
- **Oar** — A long wooden instrument with a flat blade at one end, used for propelling boats.
- **Outboard**—Away from the center or toward the outside of the boat.
- **Painter** — A line attached to the bow of a boat used for making it fast.
- **PFD** — Personal flotation device.
- **Pitch** — The fore or aft movement as the bow and stern rise and fall due to wave action.
- **Planing Hull** — Type of hull that is shaped to glide easily across the water at high speeds.
- **Point**—One of 32 points of the compass equal to 11¼ degrees. There are 10, 12, 20 and 32 point lights indicating the arc of the compass through which they are visible. A 32 point light is one visible from every point in the compass or all around the horizon. A sailboat's ability to sail close to the wind.
- **Port** — The left side of a boat when you are facing toward the bow, also a destination.
- **Privileged Vessel**—The vessel with the right-of-way. Also called the stand-on vessel.
- **Propeller** — Equipment piece connected to lowest part of drive shaft on all motors. It spins to move boat.
- **Rib** — An athwartship frame on a boat.
- **Rigging**—The general term for all the lines or ropes.
- **Roach**—The curved stern edge of a sail.
- **Roll** — The sideward motion of a boat caused by wind and waves.
- **Rudder** — A device used for steering and maneuvering, attached to a stern or rudder post — not necessary on outboards because the unit can be moved to change direction of thrust.
- **Rules of the Road** — The international regulations for preventing collisions at sea.
- **Sailboat** — A boat powered by wind and sails which may or may not have an auxiliary engine.
- **Scope** — The length of the anchor line or chain. 6 to 1 scope means that the length of the anchor line from the boat to the anchor is 6 times the depth of the water.
- **Scupper** — A hole allowing water to run off the deck.
- **Sea Anchor**—A drag thrown over the bow to keep a boat pointed into the wind or sea.
- **Sheets**—Lines used to trim a sail.
- **Shrouds** — Those wires or lines that run down from a mast to the sides of the boat and serve as bracing.
- **Spar** — General term for masts, yards, booms, etc.
- **Spar Buoy** — (or black can, Buoy) — A channel marker bearing an uneven number and showing the port side of a channel from seaward.
- **Spinnaker** — A light sail, usually of considerable spread, roughly triangular and fully cut, which is hoisted forward of the mast and used for increased speed when reaching or running.
- **Splice**—To join two lines together permanently by weaving them together.
- **Spreader** — A bar or strut that projects from a mast in order to spread shrouds or stays and give better support to a mast.
- **Squall**—A brief storm that arrives suddenly.
- **Stand-On (Privileged) Vessel** — The vessel with the right-of-way.
- **Starboard** — The right side of a boat when you are facing toward the bow.
- **Stay**— A line or wire to support a mast in a fore-and-aft direction.
- **Stern** — The after end or back of a boat.
- **Stem**—The upright post or bar of the bow.
- **Stow**—To pack the cargo.
- **Strake** — Planks running fore and aft on the outside of a vessel.
- **Tack** — To come about, so that the wind from one side is brought around to other.
- **Taffrail**—The rail around a boat's stern.
- **Thwart**—A seat extending horizontally on a boat.
- **Tide** — The alternate rise and fall of waters caused by the gravitational attraction of moon and sun.
- **Tiller** — A bar or handle for turning a boat's rudder or an outboard motor.
- **Transom** — The planking which forms the after end of a small square-stern boat. (Outboard motors are mounted here.)
- **Trapeze** — A wire secured near the top of the mast, with a seat or sling on its lower end. In strong breezes a crewman can support himself in the trapeze and extend himself far out over the water to counteract the heeling force of the wind.
- **Trim** — To arrange weights in a vessel in such manner as to obtain desired draft at bow and stern.
- **Trimaran** — Sailboat with three hulls, the center one being the largest.
- **Unbend** — To cast off or untie.
- **Underway** — Vessel in motion, i.e., when not moored, at anchor or aground.
- **Vessel**—Watercraft, other than seaplanes, capable of being used as transportation on the water.
- **Wake** — Moving waves, track or path that a boat leaves behind it, when moving across the waters.
- **Waterline**—A line on a boat's hull which indicates proper trim.
- **Way** — Movement of a vessel through the water. Technically it is *under way* when not at anchor, aground or made fast to the shore. The common usage is interpreted as progress through the water: *Headway* when going forward and *Sternway* when it is going backwards or astern.
- **Well** — Area at the rear of a boat in which the motor is sometimes installed.
- **Whipping** — A method of preventing the ends of a line from unraveling.
- **Windward**—Toward the wind.

WHAT MAKES A GOOD SKIPPER?

- 1. The first duty of a good skipper is the safety of the boat and its passengers.*
- 2. A good skipper is always in control of the craft and the situation.*
- 3. A good skipper knows the laws and rules and obeys them.*
- 4. A good skipper does not stretch his ability or that of the boat.*
- 5. A good skipper knows the job, the boat and its equipment.*
- 6. A good skipper studies boating and updates knowledge.*
- 7. A good skipper keeps a checklist on safety equipment and goes over it each time before casting off.*
- 8. A good skipper takes all necessary supplies aboard.*
- 9. A good skipper does not waste fuel supplies or energy.*
- 10. A good skipper always plots the safest course and stays on it.*
- 11. A good skipper is thoughtful of other boats and people.*
- 12. A good skipper is always alert to danger.*
- 13. A good skipper aids others in danger or distress.*
- 14. A good skipper does not take chances.*
- 15. A good skipper thinks before acting.*
- 16. A good skipper keeps the craft clean and shipshape.*
- 17. A good skipper keeps a log.*



Are you a good skipper?

**THIS WON'T
SAVE YOUR LIFE**



**UNLESS YOU'RE
WEARING IT**

DEPARTMENT OF TRANSPORTATION
UNITED STATES COAST GUARD

Revenue to state if boating bill passes

@ \$5/boat \$ 450,000 /yr on registration or more
~ 200,000 on titling

250,000 if fed. law passes

+ penalties

200,000

Coast Guard budget
200,000

Registration can be done by 1 person
in Juneau

Public Safety may try to budget
offices all over state

Motor Vehicle Field offices could handle
it all - little added expense

Do State Police & Troopers have boats now

June 270

David Illuminate

SSHB 390

586-7300

Testifying

Sec. for Harbor Masters Ass.

George V. McCorkle

Harbor Master Kodiak

Box 1397

99615

486-5438

3682

Notify when
78390 is scheduled

~~George V. McCorkle~~

Find letter
from Harbor Master
Assoc.

3:00
Mon 25th
& Public
Safety

4322



THE FOLLOWING DOCUMENT(S) MAY NOT FILM
LEGIBLY BECAUSE OF POOR QUALITY OF THE
ORIGINAL.

THE PRECEDING DOCUMENT(S) MAY NOT FILM
LEGIBLY BECAUSE OF POOR QUALITY OF THE
ORIGINAL.



Public Law 92-75
92nd Congress, H. R. 19
August 10, 1971

An Act

To provide for a coordinated national boating safety program.

Be it enacted by the Senate and House of Representatives of the United States of America in Congress assembled, That this Act may be cited as the "Federal Boat Safety Act of 1971".

Federal Boat
Safety Act of
1971.

DECLARATION OF POLICY AND PURPOSE

Sec. 2. It is hereby declared to be the policy of Congress and the purpose of this Act to improve boating safety and to foster greater development, use, and enjoyment of all the waters of the United States by encouraging and assisting participation by the several States, the boating industry, and the boating public in development of more comprehensive boating safety programs; by authorizing the establishment of national construction and performance standards for boats and associated equipment; and by creating more flexible regulatory authority concerning the use of boats and equipment. It is further declared to be the policy of Congress to encourage greater and continuing uniformity of boating laws and regulations as among the several States and the Federal Government, a higher degree of reciprocity and comity among the several jurisdictions, and closer cooperation and assistance between the Federal Government and the several States in developing, administering, and enforcing Federal and State laws and regulations pertaining to boating safety.

85 STAT. 213
85 STAT. 214

DEFINITIONS

Sec. 3. As used in this Act, and unless the context otherwise requires—

(1) "Boat" means any vessel—

(A) manufactured or used primarily for noncommercial use;

or

(B) leased, rented, or chartered to another for the latter's non-commercial use; or

(C) engaged in the carrying of six or fewer passengers.

(2) "Vessel" includes every description of watercraft, other than a seaplane on the water, used or capable of being used as a means of transportation on the water.

(3) "Undocumented vessel" means a vessel which does not have and is not required to have a valid marine document as a vessel of the United States.

(4) "Use" means operate, navigate, or employ.

(5) "Passenger" means every person carried on board a vessel other than—

(A) the owner or his representative;

(B) the operator;

(C) bona fide members of the crew engaged in the business of the vessel who have contributed no consideration for their carriage and who are paid for their services; or

(D) any guest on board a vessel which is being used exclusively for pleasure purposes who has not contributed any consideration, directly, or indirectly, for his carriage.

(6) "Owner" means a person who claims lawful possession of a vessel by virtue of legal title or equitable interest therein which entitles him to such possession.

(This Act
is 16 pages
long)

- (7) "Manufacturer" means any person engaged in—
 (A) the manufacture, construction, or assembly of boats or associated equipment; or
 (B) the manufacture or construction of components for boats and associated equipment to be sold for subsequent assembly; or
 (C) the importation into the United States for sale of boats, associated equipment, or components thereof.
- (8) "Associated equipment" means—
 (A) any system, part, or component of a boat as originally manufactured or any similar part or component manufactured or sold for replacement, repair, or improvement of such system, part, or component;
 (B) any accessory or equipment for, or appurtenance to, a boat; and
 (C) any marine safety article, accessory, or equipment intended for use by a person on board a boat; but
 (D) excluding radio equipment.
- (9) "Secretary" means the Secretary of the Department in which the Coast Guard is operating.
- (10) "State" means a State of the United States, the Commonwealth of Puerto Rico, the Virgin Islands, Guam, American Samoa, and the District of Columbia.
- (11) "Eligible State" means one that has a State boating safety program which has been accepted by the Secretary.

APPLICABILITY

SEC. 4. (a) This Act applies to vessels and associated equipment used, to be used, or carried in vessels used, on waters subject to the jurisdiction of the United States and on the high seas beyond the territorial seas for vessels owned in the United States.

(b) Sections 5 through 11 and subsections 12(a) and 12(b) of this Act are applicable also to boats moving or intended to be moved in interstate commerce.

(c) This Act, except those sections where the content expressly indicates otherwise, does not apply to—

- (1) foreign vessels temporarily using waters subject to United States jurisdiction;
- (2) military or public vessels of the United States, except recreational-type public vessels;
- (3) a vessel whose owner is a State or subdivision thereof, which is used principally for governmental purposes, and which is clearly identifiable as such;
- (4) ships' lifeboats.

BOAT AND ASSOCIATED EQUIPMENT STANDARDS AND USE

SAFETY REGULATIONS AND STANDARDS

SEC. 5. (a) The Secretary may issue regulations—

- (1) establishing minimum safety standards for boats and associated equipment, and establishing procedures and tests required to measure conformance with such standards. Each standard shall be reasonable, shall meet the need for boating safety, and shall be stated, insofar as practicable, in terms of performance;
- (2) requiring the installation, carrying, or using of associated equipment on boats and classes of boats subject to this Act; and prohibiting the installation, carrying, or using of associated equipment which does not conform with safety standards established

under this section. Equipment contemplated by this clause includes, but is not limited to, fuel systems, ventilation systems, electrical systems, navigational lights, sound producing devices, fire fighting equipment, lifesaving devices, signaling devices, ground tackle, life and grab rails, and navigational equipment.

(b) A regulation or standard issued under this section—

(1) shall specify an effective date which is not earlier than one hundred and eighty days from the date of issuance, except that this period shall be increased in the discretion of the Secretary to not more than eighteen months in any case involving major product design, retooling, or major changes in the manufacturing process, unless the Secretary finds that there exists a boating safety hazard so critical as to require an earlier effective date; what constitutes major product redesign, retooling, or major changes shall be determined by the Secretary;

(2) may not compel substantial alteration of a boat or item of associated equipment which is in existence, or the construction or manufacture of which is commenced before the effective date of the regulation; but subject to that limitation may require compliance or performance to avoid a substantial risk of personal injury to the public that the Secretary considers appropriate in relation to the degree of hazard that the compliance will correct; and

(3) shall be consistent with laws and regulations governing the installation and maintenance of sanitation equipment.

PREScribing REGULATIONS AND STANDARDS

SEC. 6. In establishing a need for formulating and prescribing regulations and standards under section 5 of this Act, the Secretary shall, among other things—

(1) consider the need for and the extent to which the regulations or standards will contribute to boating safety;

(2) consider relevant available boat safety standards, statistics and data, including public and private research, development, testing, and evaluation;

(3) consider whether any proposed regulation or standard is reasonable and appropriate for the particular type of boat or associated equipment for which it is prescribed;

(4) consult with the Boating Safety Advisory Council established pursuant to section 33 of this Act regarding all of the foregoing considerations.

DISPLAY OF LABELS EVIDENCING COMPLIANCE

SEC. 7. The Secretary may require or permit the display of seals, labels, plates, insignia, or other devices for the purpose of certifying or evidencing compliance with Federal safety regulations and standards for boats and associated equipment.

DELEGATION OF INSPECTION FUNCTION

SEC. 8. The Secretary may, subject to such regulations, supervision, and review as he may prescribe, delegate to any person, or private or public agency, or to any employee under the supervision of such person or agency, any work, business, or function respecting the examination, inspection, and testing necessary for compliance enforcement or for the development of data to enable the Secretary to prescribe and to issue regulations and standards, under sections 5 and 6 of this Act.

EXEMPTIONS

SEC. 9. The Secretary may, if he considers that boating safety will not be adversely affected, issue exemptions from any provision of this Act or regulations and standards established thereunder, on terms and conditions as he considers appropriate.

FEDERAL PREEMPTION

SEC. 10. Unless permitted by the Secretary under section 9 of this Act, no State or political subdivision thereof may establish, continue in effect, or enforce any provision of law or regulation which establishes any boat or associated equipment performance or other safety standard, or which imposes any requirement for associated equipment, except, unless disapproved by the Secretary, the carrying or using of marine safety articles to meet uniquely hazardous conditions or circumstances within the State, which is not identical to a Federal regulation issued under section 5 of this Act.

ADMISSION OF NONCONFORMING FOREIGN-MADE BOATS

SEC. 11. The Secretary of the Treasury and the Secretary may, by joint regulations, authorize the importation of a nonconforming boat or associated equipment upon terms and conditions, including the furnishing of bond, which will assure that the boat or associated equipment will be brought into conformity with the applicable Federal safety regulations and standards before it is used on waters subject to the jurisdiction of the United States.

PROHIBITED ACTS

SEC. 12. (a) No person shall—

(1) manufacture, construct, assemble, introduce, or deliver for introduction in interstate commerce, or import into the United States, or if engaged in the business of selling or distributing boats or associated equipment, sell or offer for sale, any boat, associated equipment, or component thereof to be sold for subsequent assembly, unless—

(A) it conforms with regulations and standards prescribed under this Act, or

(B) it is intended solely for export, and so labeled, tagged, or marked on the boat or equipment and on the outside of the container, if any, which is exported.

(2) fix, attach, or display a seal, label, plate, insignia, or other device indicating or suggesting compliance with Federal safety standards, on, in, or with a boat or item of associated equipment, which is false or misleading;

(3) fail to furnish a notification as required by section 15(a) or exercise reasonable diligence in fulfilling the undertaking given pursuant to section 15(c) of this Act.

(b) No person shall be subject to any penalty contained in this section if he establishes that he did not have reason to know in the exercise of due care that a boat or associated equipment does not conform with applicable Federal boat safety standards, or who holds a certificate issued by the manufacturer of the boat or associated equipment to the effect that such boat or associated equipment conforms to all applicable Federal boat safety standards, unless such person knows or reasonably should have known that such boat or associated equipment does not so conform.

(c) No person may use a vessel in violation of this Act or regulations issued thereunder.

(d) No person may use a vessel, including one otherwise exempted by section 4(c) of this Act, in a negligent manner so as to endanger the life, limb, or property of any person. Violations of this subsection involving use which is grossly negligent, subject the violator, in addition to any other penalties prescribed in this Act, to the criminal penalties prescribed in section 34.

(e) No vessel equipped with propulsion machinery of any type and not subject to the manning requirements of the vessel inspection laws administered by the Coast Guard, may while carrying passengers for hire, be used except in the charge of a person licensed for such service under regulations, prescribed by the Secretary, which pertain to qualifications, issuance, revocation, or suspension, and related matters.

(f) Section 12(e) of this Act shall not apply to any vessel being used for bona fide dealer demonstrations furnished without fee to business invitees. However, if on the basis of substantial evidence the Secretary determines, pursuant to section 6 hereof, that requiring vessels so used to be under the control of licensed persons is necessary to meet the need for boating safety, then the Secretary may promulgate regulations requiring the licensing of persons controlling such vessels in the same manner as provided in section 12(e) of this Act for persons in control of vessels carrying passengers for hire.

TERMINATION OF UNSAFE USE

Sec. 13. If a Coast Guard boarding officer observes a boat being used without sufficient lifesaving or firefighting devices or in an overloaded or other unsafe condition as defined in regulations of the Secretary, and in his judgment such use creates an especially hazardous condition, he may direct the operator to take whatever immediate and reasonable steps would be necessary for the safety of those aboard the vessel, including directing the operator to return to mooring and to remain there until the situation creating the hazard is corrected or ended.

INSPECTION, INVESTIGATION, REPORTING

Sec. 14. (a) Every manufacturer subject to the provisions of this Act shall establish and maintain records, make reports, and provide information as the Secretary may reasonably require to enable him to determine whether the manufacturer has acted or is acting in compliance with this Act and the regulations issued thereunder. A manufacturer shall, upon request of an officer, employee, or agent authorized by the Secretary, permit the officer, employee, or agent to inspect at reasonable times factories or other facilities, books, papers, records, and documents relevant to determining whether the manufacturer has acted or is acting in compliance with this Act and the regulations issued thereunder.

(b) All information reported to or otherwise obtained by the Secretary or his representative pursuant to subsection (a) of this section containing or relating to a trade secret or other matter referred to in section 1005 of title 18 of the United States Code or authorized to be exempted from public disclosure by subsection 552(b) of title 5, United States Code, shall be considered confidential for the purpose of that section of title 18, except that, upon approval by the Secretary, such information may be disclosed to other officers, employees, or agents concerned with carrying out this Act or when relevant in any proceeding under this Act.

NOTIFICATION OF DEFECTS; REPAIR OR REPLACEMENT

SEC. 15. (a) Every manufacturer who discovers or acquires information which he determines, in the exercise of reasonable and prudent judgment, indicates that a boat or associated equipment subject to an applicable standard or regulation prescribed pursuant to section 5 of this Act either fails to comply with such standard or regulation, or contains a defect which creates a substantial risk of personal injury to the public, shall, if such boat or associated equipment has left the place of manufacture, furnish notification of such defect or failure of compliance as provided in subsections (b) and (c) of this section, within a reasonable time after the manufacturer has discovered the defect.

Notification,
recipients.

(b) The notification required by subsection (a) of this section shall be given to the following persons in the following manner—

(1) by certified mail to the first purchaser for purposes other than resale: *Provided*, That the requirement for notification of such first purchaser shall be satisfied if the manufacturer exercises reasonable diligence in creating and maintaining a list of such purchasers and their current addresses and sends the required notice to each person on said list at the address appearing thereon;

(2) by certified mail to subsequent purchasers, if known to the manufacturer;

(3) by certified mail or other more expeditious means to the dealers or distributors of such manufacturer to whom such boat or associated equipment was delivered.

Contents.

(c) The notification required by subsection (a) of this section shall contain a clear description of such defect or failure to comply, an evaluation of the hazard reasonably related thereto, a statement of the measures to be taken to correct such defect or failure to comply, and an undertaking by the manufacturer to take such measures at his sole cost and expense.

(d) Every manufacturer shall furnish to the Secretary a true or representative copy of all notices, bulletins, and other communications to dealers or distributors of such manufacturer or to purchasers or subsequent purchasers, of boats or associated equipment of such manufacturer, regarding any defect relating to safety in such boats or associated equipment or any failure to comply with a standard, regulation, or order applicable to such boat or associated equipment. The Secretary may publish or otherwise disclose to the public so much of the information contained in such notice or other information in his possession as he deems will assist in carrying out the purposes of this Act, but shall not disclose any information which contain or relates to a trade secret unless he determines that it is necessary to carry out the purposes of this Act.

Disclosure.

(e) If through testing, inspection, investigation, research, or examination of reports carried out pursuant to this Act the Secretary determines that any boat or associated equipment subject to this Act—

(1) fails to comply with an applicable standard or regulation prescribed pursuant to section 5; or

(2) contains a defect which relates to safety,

and if the Secretary determines that notification provided under this section is appropriate, he shall notify the manufacturer of the boat or associated equipment of such defect or failure to comply. The notice shall contain the findings of the Secretary and shall include a synopsis of the information upon which the findings are based. Upon receipt of such notice, the manufacturer shall furnish the notification described in subsection (c) to the persons designated in subsection (b), unless the manufacturer disputes the Secretary's determination, in

which case the Secretary shall afford such manufacturer an opportunity to present his views to establish that there is no failure of compliance or defect relating to safety. Where the Secretary determines it is in the public interest, he may publish notice of such proceeding in the Federal Register and afford interested persons, including the Boating Safety Advisory Council, an opportunity to comment thereon. If after such presentation by the manufacturer the Secretary determines that such boat or associated equipment does not comply with an applicable standard or regulation, or that it contains a defect related to safety, the Secretary may direct the manufacturer to furnish the notification specified in subsection (c) of this section to the persons specified in subsection (b) of this section.

Notice; publication in Federal Register.

(f) For purposes of section 15, the term "associated equipment" includes only such items or classes of associated equipment as the Secretary shall by regulation or order prescribe after determining that the application of the requirements of this section to such items or classes of associated equipment is reasonable, appropriate, and in furtherance of the purposes of this Act.

"Associated equipment."

(g) The Secretary is authorized to promulgate regulations defining and establishing procedures and otherwise furthering the purposes of this section.

Rule making powers.

RENDERING OF ASSISTANCE IN CASUALTIES

SEC. 16. (a) The operator of a vessel, including one otherwise exempted by subsection 4(c) of this Act, involved in a collision, accident, or other casualty, to the extent he can do so without serious danger to his own vessel, or persons aboard, shall render all practical and necessary assistance to persons affected by the collision, accident, or casualty to save them from danger caused by the collision, accident, or casualty. He shall also give his name, address, and the identification of his vessel to any person injured and to the owner of any property damaged. The duties imposed by this subsection are in addition to any duties otherwise imposed by law.

Vessel operator, duties.

(b) Any person who complies with subsection (a) of this section or who gratuitously and in good faith renders assistance at the scene of a vessel collision, accident, or other casualty without objection of any person assisting, shall not be held liable for any civil damages as a result of the rendering of assistance or for any act or omission in providing or arranging salvage, towage, medical treatment, or other assistance where the assisting person acts as an ordinary, reasonably prudent man would have acted under the same or similar circumstances.

Liability exemption.

NUMBERING OF CERTAIN VESSELS

VESSELS REQUIRING NUMBERING

SEC. 17. An undocumented vessel equipped with propulsion machinery of any type shall have a number issued by the proper issuing authority in the State in which the vessel is principally used.

STANDARD NUMBERING

SEC. 18. (a) The Secretary shall establish by regulation a standard numbering system for vessels. Upon application by a State the Secretary shall approve a State numbering system which is in accord with the standard numbering system and the provisions of this Act relating to numbering and casualty reporting. A State with an approved system is the issuing authority under the Act. The Secretary is the issuing authority in States where a State numbering system has not been approved.

44 USC 507
note.

(b) If a State has a numbering system approved by the Secretary under the Act of September 2, 1958 (72 Stat. 1754), as amended, prior to enactment hereof, the system need not be immediately revised to conform with this Act and may continue in effect without change for a period not to exceed three years from the date of enactment of this Act.

(c) When a vessel is actually numbered in the State of principal use, it shall be considered as in compliance with the numbering system requirements of any State in which it is temporarily used.

(d) When a vessel is removed to a new State of principal use, the issuing authority of that State shall recognize the validity of a number awarded by any other issuing authority for a period of at least sixty days before requiring numbering in the new State.

(e) If a State has a numbering system approved after the effective date of this Act, that State must accept and recognize any certificate of number issued by the Secretary, as the previous issuing authority in that State, for one year from the date that State's system is approved, or until its expiration date, at the option of the State.

(f) Whenever the Secretary determines that a State is not administering its approved numbering system in accordance with the standard numbering system, or has altered its system without his approval, he may withdraw his approval after giving notice to the State, in writing, setting forth specifically wherein the State has failed to meet the standards required, and the State has not corrected such failures within a reasonable time after being notified by the Secretary.

EXEMPTIONS

Sec. 19. (a) The Secretary, when he is the issuing authority, may exempt a vessel or class of vessels from the numbering provisions of this Act under such conditions as he may prescribe.

(b) When a State is the issuing authority, it may exempt from the numbering provisions of this Act any vessel or class of vessels that has been exempted under subsection (a) of this section or otherwise as permitted by the Secretary.

DESCRIPTION OF CERTIFICATE OF NUMBER

Sec. 20. (a) A certificate of number granted under this Act shall be pocket size, shall be at all times available for inspection on the vessel for which issued when the vessel is in use, and may not be valid for more than three years. The certificate of number for vessels less than twenty-six feet in length and leased or rented to another for the latter's noncommercial use of less than twenty-four hours may be retained on shore by the vessel's owner or his representative at the place from which the vessel departs or returns to the possession of the owner or his representative. A vessel which does not have the certificate of number on board shall be identified while in use, and comply with such other requirements, as the issuing authority prescribes.

(b) The owner of a vessel numbered under this Act shall furnish to the issuing authority notice of the transfer of all or part of his interest in the vessel, or of the destruction or abandonment of the vessel, within a reasonable time thereof, and shall furnish notice of any change of address within a reasonable time of the change, in accordance with prescribed regulations.

DISPLAY OF NUMBER

Sec. 21. A number required by this Act shall be painted on, or attached to, each side of the forward hull of the vessel for which it was

issued, and shall be of the size, color, and type as may be prescribed by the Secretary. No other number may be carried on the forward half of the vessel.

SAFETY CERTIFICATES

Sec. 22. When a State is the issuing authority it may require that the operator of a numbered vessel hold a valid safety certificate issued under terms and conditions set by the issuing authority.

REGULATIONS

Sec. 23. The issuing authority may prescribe regulations and establish fees to carry out the intent of sections 17 through 24 and section 37 of this Act. A State issuing authority may impose only terms and conditions for vessel numbering (1) which are prescribed by this Act or the regulations of the Secretary concerning the standard numbering system, or (2) which relate to proof of payment of State or local taxes.

FURNISHING OF INFORMATION

Sec. 24. Any person may request from an issuing authority vessel numbering and registration information which is retrievable from vessel numbering system records of the issuing authority. When the issuing authority is satisfied that the request is reasonable and related to a boating safety purpose, the information shall be furnished upon payment by such person of the cost of retrieval and furnishing of the information requested.

STATE BOATING SAFETY PROGRAMS

ESTABLISHMENT AND ACCEPTANCE

Sec. 25. In order to encourage greater State participation and consistency in boating safety efforts, and particularly greater safety patrol and enforcement activities, the Secretary may accept State boating safety programs directed at implementing and supplementing this Act. Acceptance is necessary for a State to receive full rather than partial Federal financial assistance under this Act. The Secretary may also make Federal funds available to an extent permitted by subsection 27(d) of this Act to national nonprofit public service organizations for national boating safety programs and activities which he considers to be in the public interest.

BOATING SAFETY PROGRAM CONTENT

Sec. 26. (a) The Secretary shall accept a State boating safety program which—

(1) incorporates a State vessel numbering system previously approved under this Act or includes such a numbering system as part of the proposed boating safety program;

(2) includes generally the other substantive content of the Model State Boat Act as approved by the National Association of State Boating Law Administrators in conjunction with the Council of State Governments, or is in substantial conformity therewith, or conforms sufficiently to insure uniformity and promote comity among the several jurisdictions;

(3) provides for patrol and other activity to assure enforcement of the State boating safety laws and regulations;

(4) provides for boating safety education programs;

(5) designates the State authority or agency which will administer the boating safety program and the allocated Federal funds; and

(6) provides that the designated State authority or agency will submit reports in the form prescribed by the Secretary.

(b) The requirements of subparagraph (a) (2) of this section shall be liberally construed to permit acceptance where the general intent and purpose of such requirements are met and nothing contained therein is in any way intended to discourage a State program which is more extensive or comprehensive than suggested herein, particularly with the regard to safety patrol and enforcement activity commensurate with the amount and type of boating activity within the State, and with regard to public boat safety education, and experimental programs which could enhance boating safety.

ALLOCATION OF FEDERAL FUNDS

Sec. 27. (a) The Secretary shall allocate the amount appropriated to the several States as soon as practicable after July 1 of each fiscal year for which the funds are appropriated.

(b) In order to encourage and assist the States in the development of boating safety programs during the first three fiscal years for which funds are available under this Act, the funds shall be allocated among applying States having a boating safety program, or which indicate to the Secretary their intention to establish boating safety programs in accordance with section 25 of this Act. One-half of the funds shall be allocated equally among the applying States. The other half shall be allocated to each applying State in the same ratio as the number of vessels propelled by machinery numbered in that State bears to the number of such vessels numbered in all applying States.

(c) In fiscal years after the third fiscal year for which funds are available under this Act the moneys appropriated shall be allocated among applying States. Of the total available funds one-third shall be allocated each year equally among applying States. One-third shall be allocated so that the amount each year to each applying eligible State will be in the same ratio as the number of vessels numbered in that State, under a numbering system approved under this Act, bears to the number of such vessels numbered in all applying eligible States. The remaining one-third shall be allocated so that the amount each year to each applying eligible State shall be in the same ratio as the State funds expended or obligated for the State boating safety program during the previous fiscal year by a State bears to the total State funds expended or obligated for that fiscal year by all the applying eligible States.

(d) The Secretary may allocate not more than 5 per centum of funds appropriated in any fiscal year for national boating safety activities of one or more national nonprofit-public service organizations.

ALLOCATION LIMITATIONS; UNOBLIGATED OR UNALLOCATED FUNDS

Sec. 28. (a) Notwithstanding the allocation ratios prescribed in section 27 of this Act, the Federal share of the total annual cost of a State's boating safety program may not exceed 75 per centum in fiscal year 1972, 66 $\frac{2}{3}$ per centum in fiscal year 1973, 50 per centum in fiscal year 1974, 40 per centum in fiscal year 1975, and 33 $\frac{1}{3}$ per centum in fiscal year 1976. No State may receive more than 5 per centum of the Federal funds appropriated or available for allocation in any fiscal year.

Limitation.

(b) Amounts allocated to a State shall be available for obligation by that State for a period of three years following the date of allocation. Funds unobligated by the State at the expiration of the three-year period shall be withdrawn by the Secretary and shall be available with other funds to be allocated by the Secretary during that fiscal year.

(c) Funds available to the Secretary which have not been allocated at the end of a fiscal year shall be carried forward as part of the total allocation funds for the next fiscal year for which appropriations are authorized by this Act.

DETERMINATION OF STATE FUNDS EXPENDED

Sec. 29. In accordance with regulations prescribed by the Secretary computation by a State of funds expended or obligated for the boating safety program shall include the acquisition, maintenance, and operating costs of facilities, equipment, and supplies; personnel salaries and reimbursable expenses; the costs of training personnel; public boat safety education; the costs of administering the program; and other expenses which the Secretary considers appropriate. The Secretary shall determine any issues which arise in connection with such computation.

AUTHORIZATION FOR APPROPRIATIONS FOR STATE BOATING SAFETY PROGRAMS

Sec. 30. For the purpose of providing financial assistance for State boating safety programs there is authorized to be appropriated \$7,500,000 for the fiscal year ending June 30, 1972, and \$7,500,000 for each of the four succeeding fiscal years, such appropriations to remain available until expended.

PAYMENTS

Sec. 31. (a) Amounts allocated under section 27 of this Act shall be computed and paid to the States as follows:

(1) During the first three fiscal years that funds are available the Secretary shall schedule the initial payment to each State at the earliest possible time after application and compliance with subsection 27(b) of this Act.

(2) For fiscal years after the third fiscal year for which funds are available, the Secretary shall determine during the last quarter of a fiscal year, on the basis of computations made pursuant to section 29 of this Act and submitted by the States, the percentage of the funds available for the next fiscal year to which each eligible State shall be entitled. Notice of the percentage and of the dollar amount, if it can then be determined, for each State shall be furnished to the States at the earliest practicable time. If the Secretary finds that an amount made available to a State for a prior year is greater or less than the amount which should have been made available to that State for the prior year, because of later or more accurate State expenditure information, the amount for the current fiscal year may be increased or decreased by the appropriate amount.

(b) Notwithstanding any other provision of law, the Secretary shall schedule the payment of funds consistent with the program purposes and applicable Treasury regulations, so as to minimize the time elapsing between the transfer of funds from the United States Treasury and the subsequent disbursement thereof by a State.

Failure to comply, payments termination.

(c) Whenever the Secretary, after reasonable notice to the designated State authority or agency, finds that—

(1) the boating safety program submitted by the State and accepted by the Secretary has been so changed that it no longer complies with this Act or standards established by regulations thereunder; or

(2) in the administration of the boating safety program, there has been a failure to comply substantially with the standards established by the regulations;

the Secretary shall notify the State authority or agency that no further payments will be made to the State until the program conforms to the established standards or the failure is corrected.

Records, availability for audit.

(d) The Secretary shall, by regulation, provide for such accounting, budgeting, and other fiscal procedures as are necessary and reasonable for the proper and efficient administration of this section. The Secretary and the Comptroller General of the United States shall have access for the purpose of audit and examination, to any books, documents, papers, and records that are pertinent to Federal funds allocated under this Act.

CONSULTATION AND COOPERATION

SEC. 32. (a) In carrying out his responsibilities under this Act the Secretary may consult with State and local governments, public and private agencies, organizations and committees, private industry, and other persons having an interest in boating and boating safety.

Coast Guard, jurisdiction.

43 Stat. 105.

14 USC 521.

(b) The Secretary may advise, assist, and cooperate with the States and other interested public and private agencies, in the planning, development, and execution of boating safety programs. Acting under the authority of section 141 of title 14, United States Code, and consonant with the policy defined in section 2 of this Act, the Secretary shall insure the fullest cooperation between the State and Federal authorities in promoting boating safety by entering into agreements and other arrangements with the State whenever possible. Subject to the provisions of chapter 23, title 14, he may make available, upon request from a State, the services of members of the Coast Guard Auxiliary to assist the State in the promotion of boating safety on State waters.

BOATING SAFETY ADVISORY COUNCIL

Membership.

SEC. 33. (a) The Secretary shall establish a National Boating Safety Advisory Council (hereinafter referred to as "the Council"), which shall not exceed twenty-one members, whom the Secretary considers to have a particular expertise, knowledge, and experience in boating safety. Insofar as practical, to assure balanced representation, members shall be drawn equally from (1) State officials responsible for State boating safety programs, (2) boat and associated equipment manufacturers, and (3) boating organizations and members of the general public. Additional persons from those sources may be appointed to panels to the Council which will assist the Council in the performance of its functions.

(b) In addition to the consultation required by section 6 of this Act the Secretary shall consult with the Council on any other major boat safety matters related to this Act.

(c) Members of the Council or panels may be compensated at a rate not to exceed the rate provided for Federal classified employees of grade GS-15 when engaged in the duties of the Council Members, while away from their homes or regular places of business, may be allowed travel expenses, including a per diem in lieu of subsistence as authorized by section 5703 of title 5, United States Code, for persons in the Government service employed intermittently. Payments under this section shall not render members of the Council employees or officials of the United States for any purposes.

Compensation.

5 USC 5332 note.

80 Stat. 499;

83 Stat. 190.

CRIMINAL PENALTIES

Sec. 34. Any person who willfully violates section 12(c) of this Act or the regulations issued thereunder shall be fined not more than \$1,000 for each violation or imprisoned not more than one year, or both.

CIVIL PENALTIES

Sec. 35. (a) In addition to any other penalty prescribed by law any person who violates subsection 12(a) of this Act shall be liable to a civil penalty of not more than \$2,000 for each violation, except that the maximum civil penalty shall not exceed \$100,000 for any related series of violations. Whenever any corporation violates section 12(a) of this Act, any director, officer, or executive employee of such corporation who knowingly and willfully ordered or knowingly and willfully authorized such violation shall be individually liable to the civil penalties contained herein, in addition to the corporation: *Provided, however*, That no such director, officer, or executive employee shall be individually liable under this subsection if he can demonstrate, by a preponderance of the evidence, (1) that said order or authorization was issued on the basis of a determination, in the exercise of reasonable and prudent judgment, that the nonconformity with standards and regulations constituting such violation would not cause or constitute a substantial risk of personal injury to the public, and (2) that at the time of said order or authorization he advised the Secretary in writing of his action under this proviso.

(b) In addition to any other penalty prescribed by law any person who violates any other provision of this Act or the regulations issued thereunder shall be liable to a civil penalty of not more than \$500 for each violation. If the violation involves the use of a vessel, the vessel, except as exempted by subsection 4(c) of this Act, shall be liable and may be proceeded against in the district court of any district in which the vessel may be found.

(c) The Secretary may assess and collect any civil penalty incurred under this Act and, in his discretion, remit, mitigate, or compromise any penalty prior to referral to the Attorney General. Subject to approval by the Attorney General, the Secretary may engage in any proceeding in court for that purpose, including a proceeding under subsection (d) of this section. In determining the amount of any penalty to be assessed hereunder, or the amount agreed upon in any compromise, consideration shall be given to the appropriateness of such penalty in light of the size of the business of the person charged, the gravity of the violation and the extent to which the person charged has complied with the provisions of section 15 of this Act or has otherwise attempted to remedy the consequences of the said violation.

Secretary dis-

cretionary

power.

Collection, re-
ferral.

(d) When a civil penalty of not more than \$200 has been assessed under this Act, the Secretary may refer the matter for collection of the penalty directly to the Federal magistrate of the jurisdiction wherein the person liable may be found for collection procedures under supervision of the district court and pursuant to order issued by the court delegating such authority under section 636(b) of title 28, United States Code.

42 Stat. 1113.

INJUNCTIVE PROCEEDINGS

Boats or equip-
ment, U. S.
Jurisdiction.

SEC. 36. The United States district courts shall have jurisdiction to restrain violations of this Act, or to restrain the sale, offer for sale, or the introduction or delivery for introduction, in interstate commerce, or the importation into the United States, of any boat or associated equipment which is determined not to conform to Federal boat safety standards, upon petition by the Attorney General on behalf of the United States. Whenever practicable, the Secretary shall give notice to any person against whom an action for injunctive relief is contemplated and afford him an opportunity to present his views, and except in the case of knowing and willful violation, shall afford him a reasonable opportunity to achieve compliance. The failure to give notice and afford such opportunity does not preclude the granting of appropriate relief.

Notice, hearing
opportunity.

CASUALTY REPORTING SYSTEMS

SEC. 37. (a) The Secretary shall prescribe a uniform vessel casualty reporting system for vessels subject to this Act, including those otherwise exempted by paragraphs (1), (3), and (4) of section 4(c).

State reports
to Secretary.

(b) A State vessel numbering system and boating safety program approved under this Act shall provide for the reporting of casualties and accidents involving vessels. A State shall compile and transmit to the Secretary reports, information, and statistics on casualties and accidents reported to it.

Fatal casual-
ties.

(c) A vessel casualty reporting system shall provide for the reporting of all marine casualties involving vessels indicated in subsection (a) of this section and resulting in the death of any person. Marine casualties which do not result in loss of life shall be classified according to the gravity thereof, giving consideration to the extent of the injuries to persons, the extent of property damage, the dangers which casualties create, and the size, occupation or use, and the means of propulsion of the boat involved. Regulations shall prescribe the casualties to be reported and the manner of reporting.

(d) The owner or operator of a boat or vessel indicated in subsection (a) of this section and involved in a casualty or accident shall report the casualty or accident to the Secretary in accordance with regulations prescribed under this section unless he is required to report to a State under a State system approved under this Act.

(e) The Secretary shall collect, analyze, and publish reports, information, or statistics together with such findings and recommendations as he considers appropriate. If a State accident reporting system provides that information derived from accident reports, other than statistical, shall be unavailable for public disclosure, or otherwise prohibits use by the State or any person in any action or proceeding against an individual, the Secretary may utilize the information or material furnished by a State only in like manner.

Reports and recommendations, publication.

APPROPRIATIONS AUTHORIZATION

Sec. 38. There is authorized to be appropriated amounts as may be necessary to administer the provisions of this Act.

85 STAT. 227

GENERAL REGULATIONS

85 STAT. 228

Sec. 39. The Secretary may issue regulations necessary or appropriate to carry out the purposes of this Act.

SAVINGS PROVISION

Sec. 40. Compliance with this Act or standards, regulations, or orders promulgated hereunder shall not relieve any person from liability at common law or under State law.

MISCELLANEOUS PROVISIONS

Sec. 41. (a) The following are repealed:

Repeals.

(1) Section 7, as amended, and sections 13 and 14 of the Motorboat Act of 1940, Public Law 76-484, April 25, 1940 (54 Stat. 165);

76 Stat. 154;

(2) The Federal Boating Act of 1958, Public Law 85-911, September 2, 1958 (72 Stat. 1734), except subsections 6(b) and 6(t) thereof;

72 Stat. 1734;

46 USC 526f,

526i, 526m,

46 CFR 527 note;

(3) The Act of March 25, 1960, Public Law 86-396 (74 Stat. 10); and

74 Stat. 526a,

(4) The Act of August 30, 1961, Public Law 87-171 (75 Stat. 408).

75 Stat. 127,

127a, 127b,

127c,

(b) Subsection (c) of section 6 of the Federal Boating Act of 1958, September 2, 1958 (72 Stat. 1734), is amended to read as follows:

"(c) Such Act of April 25, 1940 (46 U.S.C. 526-526t), is further amended by adding at the end thereof the following new section:

46 USC 526a.

"Sec. 22. (a) This Act applies to every motorboat or vessel on the navigable waters of the United States, Guam, the Virgin Islands, the Commonwealth of Puerto Rico, and the District of Columbia, and every motorboat or vessel owned in a State and using the high seas, except that the provisions of this Act other than sections 12, 18, and 19 do not apply to boats as defined in and subject to the Federal Boat Safety Act of 1971.

"(b) As used in this Act—

"The term 'State' means a State of the United States, Guam, the Virgin Islands, the Commonwealth of Puerto Rico, and the District of Columbia."

"State."

46 USC 390 et seq.

(c) Any vessel, to the extent that it is subject to the Small Passenger Carrying Vessel Act, May 10, 1958 (70 Stat. 151), or to any other Federal inspection statute of the United States, is exempt from the provisions of this Act.

(d) Nothing contained in this Act shall be deemed to exempt from the antitrust laws of the United States any conduct that would be unlawful under such laws, or to prohibit under the antitrust laws of the United States any conduct that would be lawful under such laws.

(e) Regulations previously issued under statutory provisions repealed, modified, or amended by this Act continue in effect as though promulgated under the authority of this Act until expressly abrogated, modified, or amended by the Secretary under the regulatory authority of this Act.

(f) Any criminal or civil penalty proceeding under the Motorboat Act of 1940, as amended, or the Federal Boating Act of 1958, as amended, for a violation which occurred before the effective date of this Act may be initiated and continue to conclusion as though the former Acts had not been amended or repealed hereby.

Approved August 10, 1971.

54 Stat. 163.
46 USC 526.
72 Stat. 1754.
46 USC 527
note.

LEGISLATIVE HISTORY:

HOUSE REPORT No. 42-124 (Comm. on Merchant Marine and Fisheries).
SENATE REPORT No. 10-24 (and accompanying bill) (Comm. on Commerce).
CONGRESSIONAL RECORD, Vol. 117 (1971):
July 8, considered and passed House.
July 12, considered and passed Senate, amended, in lieu of
July 22, bill reported in Senate amendment.

AN ALASKAN TRAGEDY

WE'RE #1 WITHOUT EVEN TRYING

Since the turn of the century, boating has steadily grown to become one of the nations's most popular pastimes. Correspondingly, the boating accident statistics have also grown. As the years went by the Congress enacted several pieces of legislation to deal with the growing problem. Finally, on August 10, 1971, the Federal Boat Safety Act was signed into law establishing minimum standards which would provide the public with reasonably safe boats and equipment. At the same time the Act stressed the need for the individual states to enact equivalent legislation of their own, thus motivating the public to boating safety awareness through public education and operator and equipment requirements.

With the enactment of the Federal Boat Safety Act of 1971, the vast majority of states have recognized the inherent dangers associated with boating and during the ensuing years 47 states have enacted boating safety legislation which squarely faced the problems head on. Their actions and subsequent programs have significantly turned the tide of rising boating accidents and deaths within their states. These programs have received national acclaim for the advancements that have been made in the field of boating safety education and public protection.

To better coordinate their activities among themselves, the National Association of State Boating Law Administrators (NASBLA) was formed to serve as a viable public forum for reviewing and improving upon the federally approved state boating programs. In those states where there is no Federally approved state boating program, such as Alaska, the Coast Guard acts as the boating law administrator for areas that fall under Federal jurisdiction. Consequently, as one of only three states with this very limited federal boating safety program, Alaska's boaters are paying dearly through personal injury, loss of life and loss of property.

HERE IS JUST AN EXAMPLE.....

Alaska has more than 3 million lakes that comprise about 5.2 million acres. They may range in size from the small Arctic ponds to the 1,000 square mile Iliamna Lake. In 1978, the tragedy of boating deaths struck eight times on Alaska's lakes.

However, many more deaths occur each year on our inland rivers and in particular along Alaska's largest, the Yukon. Last year nearly a third of Alaska's boating deaths occurred on these inland rivers.

The most boating deaths occurred along Alaska's 34,000 miles of coastline. In 1978, seventy-one deaths were reported on Alaska's coastal waterways and in addition to these fatalities over \$2 million dollars in personal property was lost in boating accidents. In all, ninety-eight boating fatalities occurred on Alaskan waters last year, second only to motor vehicle fatalities as the largest category of accidental deaths. When this figure is compared with the rest of the United States, Alaska has by far the worst boating record—over 7 times the National average and 2 times more fatalities than the next leading state. (Depicted in Tables 1 and 3).

The three states with largest boating population, California, Texas, and Minnesota, rank 22nd, 35th, and 45th respectively, in the number of boating fatalities. Yet, each state alone has over 500,000 registered boats, more than 15 times the number of boats registered in Alaska. It is interesting to note that Alaska, New Hampshire, and Washington (the only three states without a state boating safety act) rank 1st, 3rd, and 8th in number of boating fatalities.

Another thing to be remembered in the case of California and Texas, is that the boating season in many areas of these states last year round, unlike Alaska, which has a boating season of 6 months or less.

It is evident from these statistics that Alaska has a severe boating problem when compared to the rest of the United States. What can we do to solve this problem or at least bring it under control?

The most effective and proven means for dealing with this problem would be to legislate a comprehensive state boating safety program.

How is a state boating safety program going to change Alaska's unenviable record of boating activity?

First of all, it will identify and charge a state agency with the responsibility for implementing a coordinated boating safety program. Not just another law enforcement program of the Department of Public Safety, but more importantly a means to implement a comprehensive public education program.

Why an education program?

With a state as vast as Alaska the emphasis needs to be focused on public education with public protection programs as a companion when necessary. The resources and expertise of the Department of Education would be utilized to assist in the development and operation of a public education program. In addition, the Coast Guard can be called upon for assistance, training and advice for program development in order to establish effective programs.

How would public protection be handled with the new law?

In addition to the education program, incorporation of the Federal boating regulations into the state boating law, as proposed, would provide procedures and policies for dealing with violators, as well as provide for the minimum operator requirements for safety equipment and boat operation. Specific sections of the act will empower state law enforcement officials with the necessary authority to carry out its provisions. Existing manpower from the Department of Public Safety could be utilized for public protection purposes without the necessity of recruiting more personnel to enforce boating laws.

Doesn't Alaska currently have state boating laws?

The existing state boating statutes cover only minimum operator requirements, which in many cases are inaccurate. This vagueness leaves the law ineffective and consequently, rarely enforced.

What about the Coast Guard, don't they enforce the federal boating laws in Alaska?

Yes, they do, but the key word here to remember is Federal. In the Federal Boat Safety Act of 1971, the Congress designated the Coast Guard as the administrator of the federal boating program and in the following year the Coast Guard inaugurated a nationwide public boating safety program. In Alaska a full time staff of ten was assembled solely to carry out the federal boating safety program, however, because of this limited manpower the program was restricted to only coastal waters. Well, needless to say, in those seven years Alaska's boating population has almost doubled, but the Coast Guard's program hasn't expanded, even in the coastal areas. In the beginning there was an initial drop in the number of fatalities, but the number of boating deaths has soared with the growing boating population. In addition to that, almost half of the boating deaths in Alaska occur on inland rivers and lakes, places that are inaccessible to the Coast Guard or in many cases out of their jurisdiction. Each year the number of complaints received by the Alaska State Troopers, the Coast Guard and other state and federal agencies concerning the negligent operation of boats continues to mount, especially along the inland rivers. Sure the Coast Guard does a good job with the resources they have available, but this growth in boating activity has reduced their effectiveness to that of a token program, with no change in sight.

Won't a new boating law create more regulations for the boater?

No! Only existing regulations will continue to be enforced. What a boating law will do is enable the state to administer and pursue a boating program with little or no federal interference thereby shifting boating control from the federal government to the state.

With the passage of a state boating safety act, where will the revenues come from to administer these programs?

Current federal funding assistance for state boating programs is scheduled to run out in Fiscal Year 1980. Other proposals have also included the establishment of Federal marine fuel taxes which would then be dispersed to only those states with Federally approved boating laws, such as this one being proposed for Alaska. The state could expect to receive somewhere in the neighborhood of \$250,000 from the proposed marine fuel tax bill.

One in-state source of revenue, but a fairly small one, would be a boat and outboard motor titling program. With the existing Coast Guard registration system, a Certificate of Numbers is not unequivocal proof of ownership. A titling program is sorely needed, both to protect the owner and any lienholders on a boat or outboard motor.

Another source of in-state revenue available and by far the largest, would be monies generated by a state operated boating registration program. At the present time this program is administered on behalf of the Federal government by the Coast Guard in Juneau, with all the revenues from this program being deposited in the U. S. Treasury. None of the revenues remain in Alaska! The program, administered on a yearly basis utilizing the fee structure as proposed, will generate approximately \$500,000 per year to directly support the state boating programs, an amount commensurate with the cost to administer the programs to be undertaken by this law.

What advantages are there to numbering boats?

Most importantly, boats need to be numbered to aid in search and rescue. For example, if a boat is found adrift or capsized, in just a matter of minutes the boat owner can be identified through the numbers on the hull and a check can be made with owner, relatives or neighbors to determine if there was anyone on board or if the boat was just adrift.

The boat registration program also provides an added benefit for the prospective boat buyer. Financial institutions will more readily lend money for the purchase of boats if some form of previous ownership can be provided.

For commercial fishermen who are applying to the Limited Entry Commission to fish in Alaskan waters, boat registration lends to the proof of vessel ownership, both past and present, as required by the Commission.

With the future development of the bottom fisheries industry, the registration of boats will be essential to facilitate effective management of those fisheries.

Boat numbers also fulfill other useful purposes. Among them law enforcement, educational contact, accident reporting and consumer defect notification.. Whether used for tracing a person for the negligent operation of a boat, to provide boating safety materials, or to notify a consumer of a possible product defect, all protect and serve the public welfare.

With the passage of a comprehensive state boating safety program won't the Coast Guard reduce its effort in boating safety in Alaska?

Quite the contrary, the Coast Guard has a dedicated commitment to boating safety in Alaska. The presence of a state boating safety program would lend a new dimension to the Coast Guard's role in this area. Specifically, the Coast Guard would assist the State in establishing its own program, provide training to educators and peace officers, and work hand and hand with state and local agencies.

But what if the legislature fails to enact a state boating safety law, what will the consequences be?

With no possibility of the Coast Guard expanding their boating program, the number of boating accidents and fatalities will continue to soar as the boating population grows.

Without a doubt the proposed state boating law will provide the boaters of Alaska with a program designed to meet their special needs without burdening the non-boater.

STATISTICS

1. Alaska has the highest fatality rate in the United States — over 7 times the National average.

2. Next to motor vehicle fatalities, boating deaths represent the largest category of accidental deaths in Alaska.

3. Of the 98 deaths that occurred on Alaskan waters in 1978, approximately 50% occurred inland — in areas presently inaccessible to the Coast Guard or out of their jurisdiction.

PRESENT STATE LAW

1. The present state boating laws are contained in Title 5, Amusements and Sports, of the Alaska State Statutes; Chapter 25, Watercraft.
2. The present law in many cases is obsolete. Being passed in 1961, the Federal laws have superseded much of the Alaska State law.
3. The remaining sections represent only a skelton law enforcement program, which is rarely enforced.

PROPOSED STATE LAW

1. Establishes a coordinated boating education program utilizing the Department of Education and other state agencies as needed..
2. Incorporates the Federal boating statutes into the state law.
3. Will establish a more effective state "public protection" program.

PROGRAM FUNDING

1. Federal Assistance
 - a. State Boating Funds -- These are due to expire in FY 80.
 - b. Proposed Marine Fuel Taxes -- Being considered by Congress to fund Federally approved state boating programs. The state could expect to receive approximately \$250,000 from this proposal.
2. State Revenues -- approximately \$500,000 will be generated from a boat registration program, based on the proposed fee schedule contained in the law. (Additional revenues may be raised from a Titling program as proposed).

COAST GUARD ASSISTANCE

1. Training and assistance will be provided by the Coast Guard for initial development of educational programs.
2. Initial training of law enforcement officers to assist in the development of an effective public protection program.
3. The Coast Guard will continue its coastal boarding program for enforcement of boating safety laws.
4. The Coast Guard will continue with present educational programs -- in relation to the Coast Guard Auxiliary.

5. The Coast Guard will remain a viable support agency for state assistance.

ADVANTAGES TO STATE IN ESTABLISHING A BOATING SAFETY PROGRAM

1. The State will assume management, administration and control versus the present Federal intervention.

2. Revenues will remain in Alaska, available for state usage, instead of being deposited with the Federal government.

3. Offers programs and protection to the entire state, not just coastal areas.

4. Expand the benefits to more than ten times the present level.

TABLE 1 TEN LEADING STATES
IN BOATING FATALITIES FOR 1977*

1. Alaska	120.00	6. North Carolina	29.94
2. W. Virginia	48.60	7. Louisiana	27.94
3. Mississippi	46.47	8. New Jersey	26.44
4. Montana	40.00	9. Virginia	26.27
5. Connecticut	30.97	10. Washington	25.69

*Number of deaths per 100,000 boats
U. S. National Average equals 16.49

TABLE 2 ACCIDENTAL DEATHS IN ALASKA FOR 1977*

1. Motor Vehicles	32.3
2. Water Transportation	14.5
3. Aircraft	10.2
4. Drownings	8.8
5. Falls	5.8
6. Fire	5.4
7. Environmental Factors	3.9

8. Poisoning	2.7
9. Firearms	2.4
10. Suffocation	0.5

*Number per 100,000 people

TABLE 3 TEN LEADING STATE
IN RECREATION BOATING FATALITIES FOR 1978*

1. ALASKA	196.8*	6. KENTUCKY	30.4
2. HAWAII	87.6	7. MISSISSIPPI	27.2
3. NEW HAMPSHIRE	43.4	8. WASHINGTON	26.0
4. W.VIRGINIA	32.0	9. LOUISIANA	25.2
5. WYOMING	31.5	10. MARYLAND	25.2

Number of deaths per
100,000 boats

U.S. National Average
equals 21.9

*Number of deaths per
100,000 with
commercial boating deaths
equals 272.2

THE LEGISLATURE OF THE STATE OF ALASKA
ELEVENTH LEGISLATURE

FISCAL NOTE

I. REQUEST

Bill/Resolution No. SSIB 390
 Title An Act relating to boating safety
 Requested by _____ Date 2/15/80

II. FISCAL DETAIL

Agency Affected Public Safety
 Program Category Affected Public Protection
 BRU, Program, or Subprogram(s) Affected Boating Safety
 (Note: If more than one budget component is affected, separate line-item amounts and funding for each component in the analysis section.)

EXPENDITURES (Thousands of Dollars)

	FY 80	FY 81	FY 82	FY 83	1Y 84	FY 85
100 PERSONAL SERVICES		300.0	1,087.5	1,087.5		
200 TRAVEL		50.0	120.0	120.0		
300 CONTRACTUAL		250.0	627.0	627.0		
400 COMMODITIES		35.0	74.0	74.0		
500 EQUIPMENT		400.0	223.2	25.0		
600 LAND & STRUCTURES						
700 GRANTS, CLAIMS, ETC.						
TOTAL		1,035.0	2,131.7	1,933.5		

FUNDING (Thousands of Dollars)

	FY 80	FY 81	FY 82	FY 83	1Y 84	FY 85
GENERAL FUND		1,035.0	2,131.7	1,933.5		
FEDERAL FUNDS						
OTHER (Specify Fund Source)						

POSITIONS

	FY 80	FY 81	FY 82	FY 83	1Y 84	FY 85
FULL TIME		10	21	21		
PART TIME		5	27	27		
TEMPORARY						

III. ANALYSIS (See Fiscal Note Preparation Instructions, Section III)

1982 would be the first year of full program operation. 1981 estimates contain most of the \$623.2 initial equipment budget, which includes 18 vehicles, \$252.0; 18 boats, \$217.0; and radios, \$46.7. Salary and benefit costs for 1982 staff are summarized: Director, Information Officer, and Secretary, \$120.6; 3 regional supervisors, \$121.5; 8 journeyman Boating Safety Officer IIs, \$293.6; 7 BSOIs, \$239.5; 15 summer aides, \$161.2; and the equivalent of 6 full-time clerical positions, \$126.1. Computer hardware and software is estimated at \$100.0. To fund interagency needs, \$100.0 is budgeted.

Costs are based upon mid 1980 prices, no inflation is added. Space, utility, communications, travel, commodities, office equipment, etc. needs are estimated for each position. More detail is available.

IV. DATE February 15, 1980 PREPARED BY Mike Clemens
 AGENCY Public Safety
 PHONE 465-4336
 Original: Legislative Finance
 cc: Budget and Management
 Prime Sponsor (First Legislator Named)

THE LEGISLATURE OF THE STATE OF ALASKA
ELEVENTH LEGISLATURE

FISCAL NOTE

I. REQUEST

Bill/Resolution No. SSHB 390
 Title "An Act relating to boating safety".
 Requested by _____ Date 2/15/80

II. FISCAL DETAIL

Agency Affected Public Safety
 Program Category Affected Public Protection
 BRU, Program, or Subprogram(s) Affected Boating Safety

(Note: If more than one budget component is affected, separate line-item amounts and funding for each component in the analysis section.)

EXPENDITURES (Thousands of Dollars)

	FY 80	FY 81	FY 82	FY 83	FY 84	FY 85
100 PERSONAL SERVICES						
200 TRAVEL						
300 CONTRACTUAL						
400 COMMODITIES						
500 EQUIPMENT						
600 LAND & STRUCTURES						
700 GRANTS, CLAIMS, ETC.						
TOTAL		(70.0)	(140.0)	(280.0)		

FUNDING (Thousands of Dollars)

GENERAL FUND		(70.0)	(140.0)	(280.0)		
FEDERAL FUNDS						
OTHER (Specify Fund Source)						

POSITIONS

FULL TIME						
PART TIME						
TEMPORARY						

III. ANALYSIS (See Fiscal Note Preparation Instructions, Sec. on III)

The purpose of this fiscal note is to explain that revenue would be collected under the proposed Certificate of Number and Certificate of Title Fees. Estimating 25,000 boats in Alaska, about \$250,000 would be collected annually for certificates of number (\$10 per boat) assuming full compliance. Certificates of title would generate \$25,000 (\$5,000 x 5) assuming 20% of the boats were sold each year. Outboard motors (25 hp & up) are estimated to be on 20% of all boats; title transfer fees would generate \$5,000 per year (25,000 x 20% = 5,000 x 20% = 1,000 x \$5 = 5,000). \$250,000 + \$25,000 + \$5,000 = \$280,000.

Revenue would increase gradually, but would not approach its full potential until at least the third year of the program. Original certificates of title would account for a larger proportion of overall revenue at first, but would later be substantially reduced. No estimate is included for cash penalties for violation of the statutes or regulations on boating safety.

IV. DATE February 15, 1980 PREPARED BY Mike Clemens
 AGENCY Public Safety
 PHONE 465-4330
 Original: Legislative Finance
 cc: Budget and Management
 Prime Sponsor (First Legislator Named)

tion of devices extends to a point five miles outside the territorial limits of the political subdivision if no other political subdivision of the state is exercising similar authority over the same devices (§ 6 ch 109 SLA 1960)

Sec. 05.20.110. Exclusion of transportation devices under jurisdiction of other agencies from chapter. This chapter does not extend to the department or to political subdivisions authority to prescribe regulations pertaining to transportation facilities or devices subject to the regulatory jurisdiction of other state or local agencies. (§ 9 ch 109 SLA 1960)

Sec. 05.20.120. Definitions. In this chapter, unless the context otherwise requires:

(1) "department" means the Department of Public Safety;

(2) "device" means a device which is designed and operated for the conveyance or movement of persons and which is used as a source of or aids in the promoting of entertainment, pleasure, play, relaxation or instruction, including but not limited to ski tows, roller coasters, merry-go-rounds and Ferris wheels. (§§ 1, 2 ch 109 SLA 1960)

Chapter 25. Watercraft.

Article

- 1. Safety Requirements (§§ 05.25.010—05.25.020)
- 2. Accidents and Liability (§§ 05.25.030—05.25.040)
- 3. General Provisions (§§ 05.25.050—05.25.100)

Article 1. Safety Requirements.

Section

- 10. Safety requirement
- 20. Water skis and surfboards

Sec. 05.25.010. Safety requirement. (a) Every watercraft operated on inland waters shall carry and exhibit between sunset and sunrise at least one white light to show all around the horizon.

(b) Every watercraft operated on inland waters shall carry at least one life preserver, or lifebelt, or ring buoy, or other device of the sort approved by the United States Coast Guard for each person on board, so placed as to be readily accessible. Every watercraft carrying passengers for hire shall carry, so placed as to be readily accessible, at least one life preserver of the sort approved by the United States Coast Guard for passenger-carrying watercraft for each person on board.

(c) Every motor-driven watercraft operated for hire shall carry a fire extinguisher capable of promptly and effectually extinguishing burning gasoline. (§ 4 ch 63 SLA 1961)

Legislative committee report.—For final bill, see House Journal (1961) legislative committee report on original page 106.

Sec. 05.25.020. Water skis and surfboards. No person may operate a watercraft on the inland waters of this state for towing

person on watercraft. The watercraft operator shall give to the person being towed a person of 12 years of age a position to observe. (5 ch 63 SLA 1961)

Section 30. Collisions, accidents

Sec. 05.25.030. operator of a watercraft shall give to the person being towed a position to observe. (5 ch 63 SLA 1961)

(b) In the case of a collision between watercraft, the operator of the watercraft at fault shall give to the other operator a full description of the accident or casualty, and to give to the other operator a full description of the damage to property in the accident, and to give to the other operator a full description of the information as to the accident. (SLA 1961)

Sec. 05.25.040. is liable for injury to his watercraft or to a state statute, or to a state statute, or to a state statute. The owner is not liable for injury to his watercraft with his express consent. The watercraft is being operated by the owner, if at the time of the accident the operator of his spouse or other member of the household is not relieved of any other liability, and does not incur any liability for injury or damage to

Section 50. Declaration of 60. Prohibited operation 70. Exemptions

person on water skis, or a surfboard, or similar devices unless (1) the watercraft is equipped with a rearview mirror in which the person being towed can be viewed, (2) or there is in the watercraft a person of 12 years of age or older in addition to the operator, in a position to observe the progress of the person being towed. (§ 5 ch 63 SLA 1961)

Article 2. Accidents and Liability.

Section	Section
30. Collisions, accidents and casualties	40. Owner's civil liability

Sec. 05.25.030. Collisions, accidents and casualties. (a) The operator of a watercraft involved in a collision, accident or casualty shall give to other persons affected by the collision, accident or casualty such assistance as may be necessary to save them from or minimize any danger caused by the collision, accident or casualty, and to give his name, address and identification of his watercraft in writing to any person injured and to the owner of any property damaged in the collision, accident or casualty.

(b) In the case of collision, accident, or casualty involving a watercraft, the operator of the watercraft, if the collision, accident or casualty results in death or injury to a person or damage to property in excess of \$100, shall file with the department a full description of the collision, accident or casualty, including such information as the department, by regulation, requires. (§ 6 ch 63 SLA 1961)

Sec. 05.25.040. Owner's civil liability. The owner of a watercraft is liable for injury or damage caused by the negligent operation of his watercraft whether the negligence consists of a violation of a state statute, or neglecting to observe ordinary care in the operation of the watercraft as the rules of the common law require. The owner is not liable, however, unless his watercraft is used with his express or implied consent. It is presumed that his watercraft is being operated with the knowledge and consent of the owner, if at the time of the injury or damage, it is under the control of his spouse, father, mother, brother, sister, son, daughter, or other member of his immediate family. This chapter does not relieve any other person from a liability which he would otherwise incur, and does not authorize or permit recovery in excess of injury or damage actually incurred. (§ 8 ch 63 SLA 1961)

Article 3. General Provisions.

Section	Section
50. Declaration of policy	80. Enforcement
60. Prohibited operation	90. Penalties
70. Exemptions	100. Definitions

Supplement

Sec. 05.25.050. Declaration of policy. It is the policy of this state to promote safety for persons and property in and connected with the use, operation and equipment of vessels in recreational pursuits in inland waters and to promote uniformity of laws relating thereto. (§ 1 ch 63 SLA 1961)

Sec. 05.25.060. Prohibited operation. (a) No person shall operate a watercraft whether for recreational purposes or any other purpose or manipulate water skis, surfboard, or similar device on inland waters in a reckless or negligent manner so as to endanger the life or property of another person.

(b) No person shall operate a watercraft whether for recreational purposes or any other purpose or manipulate water skis, surfboard, or similar device on inland waters while under the influence of any intoxicating liquor, narcotic drug, barbiturate or marijuana. (§ 3 ch 63 SLA 1961)

Sec. 05.25.070. Exemptions. Watercraft and persons operating watercraft are exempt from this chapter except § 60(b) of this chapter when participating in the area set aside for a public regatta, race, marine parade, tournament or exhibition on inland waters. (§ 7 ch 23 SLA 1961)

Sec. 05.25.080. Enforcement. Every peace officer may enforce this chapter and in the exercise of enforcement may stop and board watercraft subject to this chapter. (§ 9 ch 63 SLA 1961)

Sec. 05.25.090. Penalties. A person who violates any provision of this chapter is guilty of a misdemeanor and is punishable by a fine of not more than \$500, or by imprisonment of not more than six months, or by both, for each violation. (§ 10 ch 63 SLA 1961)

Sec. 05.25.100. Definitions. As used in this chapter, unless the content otherwise requires,

- (1) "department" means the Department of Public Safety;
- (2) "inland waters" means the water in a lake or river or stream within the territorial limits of the state;
- (3) "operate" means to navigate or otherwise use a watercraft for recreational purposes as opposed to business, subsistence or commercial purposes;
- (4) "watercraft" means every description of vessel, other than a seaplane on the water, used or capable of being used as a means of transportation on water and devoted to recreational pursuits unless otherwise expressly provided in this chapter; and excepting vessels having a valid marine document issued by the United States or foreign governments. (§ 2 ch 63 SLA 1961)

tion of devices extends to a point five miles outside the territorial limits of the political subdivision if no other political subdivision of the state is exercising similar authority over the same devices (§ 6 ch 109 SLA 1960)

Sec. 05.20.110. Exclusion of transportation devices under jurisdiction of other agencies from chapter. This chapter does not extend to the department or to political subdivisions authority to prescribe regulations pertaining to transportation facilities or devices subject to the regulatory jurisdiction of other state or local agencies. (§ 9 ch 109 SLA 1960)

Sec. 05.20.120. Definitions. In this chapter, unless the context otherwise requires:

- (1) "department" means the Department of Public Safety.
- (2) "device" means a device which is designed and operated for the conveyance or movement of persons and which is used as a source of or aids in the promoting of entertainment, pleasure, play, relaxation or instruction, including but not limited to ski tows, roller coasters, merry-go-rounds and Ferris wheels. (§§ 1, 2 ch 109 SLA 1960)

Chapter 25. Watercraft.

Article

- 1. Safety Requirements (§§ 05.25.010—05.25.020)
- 2. Accidents and Liability (§§ 05.25.030—05.25.040)
- 3. General Provisions (§§ 05.25.050—05.25.100)

Article 1. Safety Requirements.

Section

- 10. Safety requirement
- 20. Water skis and surfboards

Sec. 05.25.010. Safety requirement. (a) Every watercraft operated on inland waters shall carry and exhibit between sunset and sunrise at least one white light to show all around the horizon.

(b) Every watercraft operated on inland waters shall carry at least one life preserver, or lifebelt, or ring buoy, or other device of the sort approved by the United States Coast Guard for each person on board, so placed as to be readily accessible. Every watercraft carrying passengers for hire shall carry, so placed as to be readily accessible, at least one life preserver of the sort approved by the United States Coast Guard for passenger-carrying watercraft for each person on board.

(c) Every motor-driven watercraft operated for hire shall carry a fire extinguisher capable of promptly and effectually extinguishing burning gasoline. (§ 4 ch 63 SLA 1961)

Legislative committee report.—For final bill, see House Journal (1961) legislative committee report on original page 106.

Sec. 05.25.020. Water skis and surfboards. No person may operate a watercraft on the inland waters of this state for towing

person on watercraft. The watercraft operator shall give priority to a person of 12 years of age or under in a position to be injured. (5 ch 63 SLA 1961)

Section 30. Collisions, accidents

Sec. 05.25.030. Operator of a watercraft shall give priority to a person of 12 years of age or under in a position to be injured, and to give priority in writing to a person of 12 years of age or under in a position to be injured. (5 ch 63 SLA 1961)

(b) In the event of a collision or accident involving a watercraft, the operator shall give priority to a person of 12 years of age or under in a position to be injured, and to give priority in writing to a person of 12 years of age or under in a position to be injured. (5 ch 63 SLA 1961)

Sec. 05.25.040. Operator of a watercraft shall be liable for injury to a person of 12 years of age or under in a position to be injured, if at the time of the collision or accident the operator was operating the watercraft with his express or implied consent, or the operator of the watercraft is being operated by a person of 12 years of age or under in a position to be injured, and does not take reasonable steps to relieve any other person of 12 years of age or under in a position to be injured from injury or damage.

Section 30. Declaration of emergency. 60. Prohibited operations. 70. Exemptions

person on water skis, or a surfboard, or similar devices unless (1) the watercraft is equipped with a rearview mirror in which the person being towed can be viewed, (2) or there is in the watercraft a person of 12 years of age or older in addition to the operator, in a position to observe the progress of the person being towed. (§ 5 ch 63 SLA 1961)

Article 2. Accidents and Liability.

Section	Section
30. Collisions, accidents and casualties	40. Owner's civil liability

Sec. 05.25.030. Collisions, accidents and casualties. (a) The operator of a watercraft involved in a collision, accident or casualty shall give to other persons affected by the collision, accident or casualty such assistance as may be necessary to save them from or minimize any danger caused by the collision, accident or casualty, and to give his name, address and identification of his watercraft in writing to any person injured and to the owner of any property damaged in the collision, accident or casualty.

(b) In the case of collision, accident, or casualty involving a watercraft, the operator of the watercraft, if the collision, accident or casualty results in death or injury to a person or damage to property in excess of \$100, shall file with the department a full description of the collision, accident or casualty, including such information as the department, by regulation, requires. (§ 6 ch 63 SLA 1961)

Sec. 05.25.040. Owner's civil liability. The owner of a watercraft is liable for injury or damage caused by the negligent operation of his watercraft whether the negligence consists of a violation of a state statute, or neglecting to observe ordinary care in the operation of the watercraft as the rules of the common law require. The owner is not liable, however, unless his watercraft is used with his express or implied consent. It is presumed that his watercraft is being operated with the knowledge and consent of the owner, if at the time of the injury or damage, it is under the control of his spouse, father, mother, brother, sister, son, daughter, or other member of his immediate family. This chapter does not relieve any other person from a liability which he would otherwise incur, and does not authorize or permit recovery in excess of injury or damage actually incurred. (§ 8 ch 63 SLA 1961)

Article 3. General Provisions.

Section	Section
50. Declaration of policy	80. Enforcement
60. Prohibited operation	90. Penalties
70. Exemptions	100. Definitions

Supplement

Sec. 05.25.050. Declaration of policy. It is the policy of this state to promote safety for persons and property in and connected with the use, operation and equipment of vessels in recreational pursuits in inland waters and to promote uniformity of laws relating thereto. (§ 1 ch 63 SLA 1961)

Sec. 05.25.060. Prohibited operation. (a) No person shall operate a watercraft whether for recreational purposes or any other purpose or manipulate water skis, surfboard, or similar device on inland waters in a reckless or negligent manner so as to endanger the life or property of another person.

(b) No person shall operate a watercraft whether for recreational purposes or any other purpose or manipulate water skis, surfboard, or similar device on inland waters while under the influence of any intoxicating liquor, narcotic drug, barbiturate or marijuana. (§ 3 ch 63 SLA 1961)

Sec. 05.25.070. Exemptions. Watercraft and persons operating watercraft are exempt from this chapter except § 60(b) of this chapter when participating in the area set aside for a public regatta, race, marine parade, tournament or exhibition on inland waters. (§ 7 ch 28 SLA 1961)

Sec. 05.25.080. Enforcement. Every peace officer may enforce this chapter and in the exercise of enforcement may stop and board watercraft subject to this chapter. (§ 9 ch 63 SLA 1961)

Sec. 05.25.090. Penalties. A person who violates any provision of this chapter is guilty of a misdemeanor and is punishable by a fine of not more than \$500, or by imprisonment of not more than six months, or by both, for each violation. (§ 10 ch 63 SLA 1961)

Sec. 05.25.100. Definitions. As used in this chapter, unless the content otherwise requires,

(1) "department" means the Department of Public Safety;

(2) "inland waters" means the water in a lake or river or stream within the territorial limits of the state;

(3) "operate" means to navigate or otherwise use a watercraft for recreational purposes as opposed to business, subsistence or commercial purposes;

(4) "watercraft" means every description of vessel, other than a seaplane on the water, used or capable of being used as a means of transportation on water and devoted to recreational pursuits unless otherwise expressly provided in this chapter; and excepting vessels having a valid marine document issued by the United States or foreign governments. (§ 2 ch 63 SLA 1961)

ALASKA FEDERATION OF NATIVES, INC.



1577 'C' Street, Suite 304 . Anchorage, Alaska 99501 . Phone 907-274-3611

1979 ANNUAL CONVENTION

Resolution 79-32

WHEREAS, an amendment to the Federal Boating Safety Act of 1971 was recently introduced in Congress (H.R. 4310) by Representative Biaggi of Pennsylvania, and

WHEREAS, the primary purpose of this amendment is to "improve recreational boating safety and facilities through the development, administration, and financing of a national recreational boating safety and facilities improvement program," and

WHEREAS, for the State of Alaska to become eligible for this Federal funding, Alaska must institute a Boating Safety Act, and

WHEREAS, in 1978 and 1979, 170 individuals died in water-related accidents, and 19 others as a result of drowning, and

WHEREAS, the act will enable the State of Alaska to provide statewide boating safety sessions,

NOW THEREFORE BE IT RESOLVED, that the Alaska Federation of Natives urges the enactment of a "Recreational Boating Safety and Facilities Improvement Act".

RESOLUTION COMMITTEE RECOMMENDATION Do Pass

CONVENTION RECOMMENDATION Do Pass

Integrity . Pride in Heritage Progress

STATISTICS

1. Alaska has the highest fatality rate in the United States --- over 7 times the National average.
2. Next to motor vehicle fatalities, boating deaths represent the largest category of accidental deaths in Alaska.
3. Of the 75 deaths that occurred on Alaskan waters in 1978, approximately 50% occurred inland --- in areas presently inaccessible to the Coast Guard or out of our jurisdiction.

PRESENT STATE LAW

1. The present state boating laws are contained in Title 5, Amusements and Sports, of the Alaska State Statutes; Chapter 25, Watercraft.
2. The present law in many cases is obsolete. Being passed in 1961, the Federal laws have superseded much of the Alaska State law.
3. The remaining sections represent only a skelton law enforcement program, which is rarely enforced.

PROPOSED STATE LAW

1. Establishes a coordinated boating education program utilizing the Department of Education and other state agencies as needed.
2. Incorporates the Federal boating statutes into the state law.

3. Will establish a more effective state "public protection" program.

PROGRAM FUNDING

1. Federal Assistance

a. State Boating Funds -- These are due to expire in FY 80, however they will most likely be extended for one more year.

b. Proposed Marine Fuel Taxes -- Being considered by Congress to fund Federal'y approved state boating programs.

2. State Revenues --- approximately \$500,000 will be generated from a boat registration program, based on the proposed fee schedule contained in the law. (Additional revenues may be raised from a Titling program as proposed)

COAST GUARD ASSISTANCE

1. Training and assistance will be provided by the Coast Guard for initial development of educational programs.

2. Initial training of law enforcement officers to assist in the development of an effective public protection program.

3. The Coast Guard will continue its coastal boarding program for enforcement of boating safety laws.

4. The Coast Guard will continue with present educational programs --- in relation to the Coast Guard Auxiliary.

5. The Coast Guard will remain a viable support agency for state assistance.

ADVANTAGES TO STATE IN ESTABLISHING A BOATING SAFETY PROGRAM

1. The State will assume management, administration and control versus the present Federal intervention.

2. Revenues will remain in Alaska, available for state usage, instead being deposited with the Federal government.

3. Offers programs and protection to the entire state, not just coastal areas.

4. Expand the benefits to more than ten times the present level.